

IN THE UNITED STATES DISTRICT COURT
FOR THE MIDDLE DISTRICT OF FLORIDA
TAMPA DIVISION

UNITED STATES OF AMERICA,

Plaintiff,

v.

LANDIA CHEMICAL COMPANY,
INC.; AGRICO CHEMICAL
COMPANY; BASF SPARKS LLC;
PCS JOINT VENTURE, LTD.;
SYLVITE TERMINAL &
DISTRIBUTION LLC; BILLY G.
MITCHELL; and WALTER G.
GRAHN,

Defendants.

Civil Action No. 8:09-cv-01325-
VMC-TBM

CONSENT DECREE

04-2007-9036
04-2009-0024



10453074

TABLE OF CONTENTS

I.	BACKGROUND	1
II.	JURISDICTION.....	3
III.	PARTIES BOUND	3
IV.	DEFINITIONS	4
V.	GENERAL PROVISIONS	10
VI.	PERFORMANCE OF THE WORK BY SETTLING DEFENDANTS	13
VII.	REMEDY REVIEW.....	24
VIII.	QUALITY ASSURANCE, SAMPLING, AND DATA ANALYSIS	25
IX.	ACCESS AND INSTITUTIONAL CONTROLS.....	27
X.	REPORTING REQUIREMENTS	32
XI.	EPA APPROVAL OF PLANS AND OTHER SUBMISSIONS.....	34
XII.	PROJECT COORDINATORS	36
XIII.	PERFORMANCE GUARANTEE.....	38
XIV.	CERTIFICATION OF COMPLETION	44
XV.	EMERGENCY RESPONSE	46
XVI.	PAYMENTS FOR RESPONSE COSTS	47
XVII.	INDEMNIFICATION AND INSURANCE.....	50
XVIII.	FORCE MAJEURE.....	53
XIX.	DISPUTE RESOLUTION	55
XX.	STIPULATED PENALTIES.....	58
XXI.	COVENANTS NOT TO SUE BY PLAINTIFF	63

XXII.	COVENANTS BY SETTLING DEFENDANTS	66
XXIII.	EFFECT OF SETTLEMENT; CONTRIBUTION PROTECTION.....	68
XXIV.	ACCESS TO INFORMATION.....	69
XXV.	RETENTION OF RECORDS	71
XXVI.	NOTICES AND SUBMISSIONS	73
XXVII.	EFFECTIVE DATE	74
XXVIII.	RETENTION OF JURISDICTION.....	75
XXIX.	APPENDICES.....	75
XXX.	COMMUNITY RELATIONS	75
XXXI.	MODIFICATION	76
XXXII.	LODGING AND OPPORTUNITY FOR PUBLIC COMMENT.....	76
XXXIII.	SIGNATORIES/SERVICE	77
XXXIV.	FINAL JUDGMENT	77

I. BACKGROUND

A. The United States of America (“United States”), on behalf of the Administrator of the United States Environmental Protection Agency (“EPA”), filed a complaint in this matter pursuant to Sections 106 and 107 of the Comprehensive Environmental Response, Compensation, and Liability Act (“CERCLA”), 42 U.S.C. §§ 9606, 9607.

B. The United States in its complaint seeks, inter alia: (1) reimbursement of costs incurred by EPA and the Department of Justice for response actions at the Landia Chemical Company Site in Lakeland, Polk County, Florida, together with accrued interest; and (2) performance of studies and response work by the defendants at the Site consistent with the National Contingency Plan, 40 C.F.R. Part 300 (as amended) (“NCP”).

C. In accordance with the NCP and Section 121(f)(1)(F) of CERCLA, 42 U.S.C. § 9621(f)(1)(F), EPA notified the State of Florida (the “State”) on November 21, 2007, of negotiations with potentially responsible parties regarding the implementation of the remedial design and remedial action for the Site, and EPA has provided the State with an opportunity to participate in such negotiations and be a party to this Consent Decree.

D. In accordance with Section 122(j)(1) of CERCLA, 42 U.S.C. § 9622(j)(1), EPA notified the Department of the Interior and the National Oceanic and Atmospheric Administration on November 21, 2007, of negotiations with potentially responsible parties regarding the release of hazardous substances that may have resulted in injury to the natural resources under Federal trusteeship and encouraged the trustees to participate in the negotiation of this Consent Decree.

E. The defendants that have entered into this Consent Decree (“Settling Defendants”) do not admit any liability to the Plaintiff arising out of the transactions or

occurrences alleged in the complaint, nor do they acknowledge that the release or threatened release of hazardous substances at or from the Site constitutes an imminent or substantial endangerment to the public health or welfare or the environment.

F. Pursuant to Section 105 of CERCLA, 42 U.S.C. § 9605, EPA placed the Site on the National Priorities List, set forth at 40 C.F.R. Part 300, Appendix B, by publication in the Federal Register on May 11, 2000, 65 Fed. Reg. 30,482.

G. In response to a release or a substantial threat of a release of hazardous substances at or from the Site, Agrico Chemical Company and PCS Joint Venture, Ltd., commenced on July 28, 2000, a Remedial Investigation and Feasibility Study (“RI/FS”) for the Site pursuant to 40 C.F.R. § 300.430.

H. EPA approved a Remedial Investigation (“RI”) Report on July 9, 2003, and approved a Feasibility Study (“FS”) Report on May 29, 2007.

I. Pursuant to Section 117 of CERCLA, 42 U.S.C. § 9617, EPA published notice of the completion of the FS and of the proposed plan for remedial action on June 25, 2007, in a major local newspaper of general circulation. EPA provided an opportunity for written and oral comments from the public on the proposed plan for remedial action. A copy of the transcript of the public meeting is available to the public as part of the administrative record upon which the Regional Administrator based the selection of the response action.

J. The decision by EPA on the remedial action to be implemented at the Site is embodied in a final Record of Decision (“ROD”), executed on September 27, 2007, on which the State has given its concurrence. The ROD includes a responsiveness summary to the public comments. Notice of the final plan was published in accordance with Section 117(b) of CERCLA.

K. Based on the information presently available to EPA, the Work will be properly and promptly conducted by the Settling Defendants if conducted in accordance with the requirements of this Consent Decree and its appendices.

L. Solely for the purposes of Section 113(j) of CERCLA, the Remedial Action selected by the ROD and the Work to be performed by the Settling Defendants shall constitute a response action taken or ordered by the President.

M. The Parties recognize, and the Court by entering this Consent Decree finds, that this Consent Decree has been negotiated by the Parties in good faith and implementation of this Consent Decree will expedite the cleanup of the Site and will avoid prolonged and complicated litigation between the Parties, and that this Consent Decree is fair, reasonable, and in the public interest.

NOW, THEREFORE, it is hereby Ordered, Adjudged, and Decreed:

II. JURISDICTION

1. This Court has jurisdiction over the subject matter of this action pursuant to 28 U.S.C. §§ 1331 and 1345, and 42 U.S.C. §§ 9606, 9607, and 9613(b). This Court also has personal jurisdiction over the Settling Defendants. Solely for the purposes of this Consent Decree and the underlying complaint, Settling Defendants waive all objections and defenses that they may have to jurisdiction of the Court or to venue in this District. Settling Defendants shall not challenge the terms of this Consent Decree or this Court's jurisdiction to enter and enforce this Consent Decree.

III. PARTIES BOUND

2. This Consent Decree applies to and is binding upon the United States and upon Settling Defendants and their heirs, successors and assigns. Any change in ownership or

corporate status of a Settling Defendant including, but not limited to, any transfer of assets or real or personal property, shall in no way alter such Settling Defendant's responsibilities under this Consent Decree.

3. Settling Defendants shall provide a copy of this Consent Decree to each contractor hired to perform the Work (as defined below) required by this Consent Decree and to each person representing any Settling Defendant with respect to the Site or the Work and shall condition all contracts entered into hereunder upon performance of the Work in conformity with the terms of this Consent Decree. Settling Defendants or their contractors shall provide written notice of the Consent Decree to all subcontractors hired to perform any portion of the Work required by this Consent Decree. Settling Defendants shall nonetheless be responsible for ensuring that their contractors and subcontractors perform the Work contemplated herein in accordance with this Consent Decree. With regard to the activities undertaken pursuant to this Consent Decree, each contractor and subcontractor shall be deemed to be in a contractual relationship with the Settling Defendants within the meaning of Section 107(b)(3) of CERCLA, 42 U.S.C. § 9607(b)(3).

IV. DEFINITIONS

4. Unless otherwise expressly provided herein, terms used in this Consent Decree which are defined in CERCLA or in regulations promulgated under CERCLA shall have the meaning assigned to them in CERCLA or in such regulations. Whenever terms listed below are used in this Consent Decree or in the appendices attached hereto and incorporated hereunder, the following definitions shall apply:

- a. "Agrico" shall mean Agrico Chemical Company, a Settling Defendant.
- b. "BASF" shall mean BASF Sparks LLC, a Settling Defendant.

c. "CERCLA" shall mean the Comprehensive Environmental Response, Compensation, and Liability Act of 1980, as amended, 42 U.S.C. §§ 9601 *et seq.*

d. "Consent Decree" shall mean this Decree and all appendices attached hereto (listed in Section XXIX). In the event of conflict between this Decree and any appendix, this Decree shall control.

e. "Day" shall mean a calendar day unless expressly stated to be a working day. "Working day" shall mean a day other than a Saturday, Sunday, or Federal holiday. In computing any period of time under this Consent Decree, where the last day would fall on a Saturday, Sunday, or Federal holiday, the period shall run until the close of business of the next working day.

f. "Effective Date" shall be the effective date of this Consent Decree as provided in Paragraph 105.

g. "EPA" shall mean the United States Environmental Protection Agency and any successor departments or agencies of the United States.

h. "FDEP" shall mean the Florida Department of Environmental Protection and any successor departments or agencies of the State of Florida.

i. "Future Oversight Costs" shall mean that portion of Future Response Costs that EPA incurs in monitoring and supervising Settling Defendant's performance of the Work to determine whether such performance is consistent with the requirements of this Consent Decree, including costs incurred in reviewing plans, reports and other documents submitted pursuant to this Consent Decree, as well as costs incurred in overseeing implementation of the Work; however, Oversight Costs do not include, *inter alia*: the costs incurred by the United States pursuant to Sections VII (Remedy Review), IX (Access and Institutional Controls), and

XV (Emergency Response), and Paragraph 88 of Section XXI (Work Takeover), or the costs incurred by the United States in enforcing the terms of this Consent Decree, including all costs incurred in connection with Dispute Resolution pursuant to Section XIX (Dispute Resolution) and all litigation costs.

j. "Future Response Costs" shall mean all costs, including, but not limited to, direct and indirect costs, that the United States incurs in reviewing or developing plans, reports and other items pursuant to this Consent Decree, verifying the Work, or otherwise implementing, overseeing, or enforcing this Consent Decree, including, but not limited to, payroll costs, contractor costs, travel costs, laboratory costs, the costs incurred pursuant to Sections VII, IX (including, but not limited to, the cost of attorney time and any monies paid to secure access and/or to secure or implement institutional controls including, but not limited to, the amount of just compensation), and XV, and Paragraph 88 of Section XXI. Future Response Costs shall also include all Interim Response Costs.

k. "Grah" shall mean Walter G. Grah, a Settling Defendant.

l. "Interest," shall mean interest at the rate specified for interest on investments of the EPA Hazardous Substance Superfund established by 26 U.S.C. § 9507, compounded annually on October 1 of each year, in accordance with 42 U.S.C. § 9607(a). The applicable rate of interest shall be the rate in effect at the time the interest accrues. The rate of interest is subject to change on October 1 of each year.

m. "Interim Response Costs" shall mean all costs, including direct and indirect costs, (a) paid by the United States in connection with the Site between March 3, 2009 and the Effective Date, or (b) incurred prior to the Effective Date but paid after that date.

n. "Landia Chemical Company" shall mean Landia Chemical Company, Inc.,

a Settling Defendant.

o. “Landia Chemical Company Site Special Account” shall mean the special account established at the Site by EPA pursuant to Section 122(b)(3) of CERCLA, 42 U.S.C. § 9622(b)(3).

p. “Memorandum of Agreement” or “MOA” shall mean the Memorandum of Agreement dated September 11, 2008, and signed by EPA and the Southwest Florida Water Management District.

q. “Mitchell” shall mean Billy G. Mitchell, a Settling Defendant.

r. “National Contingency Plan” or “NCP” shall mean the National Oil and Hazardous Substances Pollution Contingency Plan promulgated pursuant to Section 105 of CERCLA, 42 U.S.C. § 9605, codified at 40 C.F.R. Part 300, and any amendments thereto.

s. “Operable Unit One” shall mean the response action being taken to remediate the soil contamination at the Site, as set forth in the ROD and summarized in Section 4.0 of the ROD.

t. “Operable Unit Two” shall mean the response action being taken to remediate the groundwater contamination at the Site, as set forth in the ROD and summarized in Section 4.0 of the ROD.

u. “Operation and Maintenance” or “O&M” shall mean all activities required to maintain the effectiveness of the Remedial Action as required under the Operation and Maintenance Plan approved or developed by EPA pursuant to this Consent Decree and the Statement of Work (“SOW”).

v. “Owner Settling Defendants” shall mean Grahn, Landia Chemical Company, Mitchell, and Sylvite.

- w. “Paragraph” shall mean a portion of this Consent Decree identified by an Arabic numeral or an upper case letter.
- x. “Parties” shall mean the United States and the Settling Defendants.
- y. “Past Response Costs” shall mean all costs, including, but not limited to, direct and indirect costs, that the United States paid at or in connection with the Site through March 3, 2009, plus Interest on all such costs which has accrued pursuant to 42 U.S.C. § 9607(a) through such date.
- z. “PCS JV” shall mean PCS Joint Venture, Ltd., a Settling Defendant.
- aa. “Performance Standards” shall mean the cleanup standards and other measures of achievement of the goals of the Remedial Action, set forth in Sections 8.0 and 12.2.4, Table 5 of the ROD and referenced in the SOW.
- bb. “Plaintiff” shall mean the United States.
- cc. “RCRA” shall mean the Solid Waste Disposal Act, as amended, 42 U.S.C. §§ 6901 *et seq.* (also known as the Resource Conservation and Recovery Act).
- dd. “Record of Decision” or “ROD” shall mean the EPA Record of Decision relating to the Landia Chemical Company Site signed on September 27, 2007, by the Regional Administrator, EPA Region 4, or his delegate, and all attachments thereto. The ROD is attached as Appendix A.
- ee. “Remedial Action” shall mean those activities, except for Operation and Maintenance, to be undertaken by the Settling Defendants to implement the ROD, in accordance with the SOW and the final Remedial Design and Remedial Action Work Plans and other plans approved by EPA.
- ff. “Remedial Action Work Plan” shall mean the document developed

pursuant to Paragraph 12 or 15 of this Consent Decree and approved by EPA, and any amendments thereto.

gg. “Remedial Design” shall mean those activities to be undertaken by the Settling Defendants to develop the final plans and specifications for the Remedial Action pursuant to the Remedial Design Work Plan.

hh. “Remedial Design Work Plan” shall mean the document developed pursuant to Paragraph 11 or 14 of this Consent Decree and approved by EPA, and any amendments thereto.

ii. “Section” shall mean a portion of this Consent Decree identified by a Roman numeral.

jj. “Settling Defendants” shall mean Landia Chemical Company, Agrico, BASF, PCS JV, Sylvite, Mitchell and Grahn.

kk. “Site” shall mean the Landia Chemical Company Site, encompassing approximately 5 acres, located at 1405 West Olive Street and 1607 West Olive Street in Lakeland, Polk County, Florida, and depicted generally on the map attached as Appendix C.

ll. “State” shall mean the State of Florida.

mm. “Statement of Work” or “SOW” shall mean the statement of work for implementation of the Remedial Design, Remedial Action, and Operation and Maintenance at the Site as set forth in Appendix B to this Consent Decree and any modifications made in accordance with this Consent Decree.

nn. “Supervising Contractor” shall mean the principal contractor retained by the Settling Defendants to supervise and direct the implementation of the Work under this Consent Decree.

- oo. "Sylvite" shall mean Sylvite Terminal & Distribution LLC, a Settling Defendant.
- pp. "United States" shall mean the United States of America.
- qq. "Waste Material" shall mean (1) any "hazardous substance" under Section 101(14) of CERCLA, 42 U.S.C. § 9601(14); (2) any pollutant or contaminant under Section 101(33), 42 U.S.C. § 9601(33); (3) any "solid waste" under Section 1004(27) of RCRA, 42 U.S.C. § 6903(27); and (4) any "hazardous material" under Title XXIX, Chapter 403.703(22) and (29) of the Florida Legislative Code.
- rr. "Work" shall mean all activities Settling Defendants are required to perform under this Consent Decree, except those required by Section XXV (Retention of Records).

V. GENERAL PROVISIONS

5. Objectives of the Parties. The objectives of the Parties in entering into this Consent Decree are to protect public health or welfare or the environment at the Site by the design and implementation of response actions at the Site by the Settling Defendants, to reimburse response costs of the Plaintiff, and to resolve the claims of Plaintiff against Settling Defendants as provided in this Consent Decree.

6. Commitments by Settling Defendants.

a. Settling Defendants shall finance and perform the Work in accordance with this Consent Decree, the ROD, the SOW, and all work plans and other plans, standards, specifications, and schedules set forth herein or developed by Settling Defendants and approved by EPA pursuant to this Consent Decree. Settling Defendants shall also reimburse the United States for Future Response Costs as provided in Paragraph 58 of this Consent Decree.

b. The obligations of Settling Defendants to finance and perform the Work and to pay amounts owed the United States under this Consent Decree are joint and several. In the event of the insolvency or other failure of any one or more Settling Defendants to implement the requirements of this Consent Decree, the remaining Settling Defendants shall complete all such requirements.

7. Compliance With Applicable Law. All activities undertaken by Settling Defendants pursuant to this Consent Decree shall be performed in accordance with the requirements of all applicable federal and state laws and regulations. Settling Defendants must also comply with all applicable or relevant and appropriate requirements of all federal and state environmental laws as set forth in the ROD and the SOW. The activities conducted pursuant to this Consent Decree, if approved by EPA, shall be considered to be consistent with the NCP.

8. Permits.

a. As provided in Section 121(e) of CERCLA and Section 300.400(e) of the NCP, no permit shall be required for any portion of the Work conducted entirely on-site (i.e., within the areal extent of contamination or in very close proximity to the contamination and necessary for implementation of the Work). Where any portion of the Work that is not on-site requires a federal or state permit or approval, Settling Defendants shall submit timely and complete applications and take all other actions necessary to obtain all such permits or approvals.

b. The Settling Defendants may seek relief under the provisions of Section XVIII (Force Majeure) of this Consent Decree for any delay in the performance of the Work resulting from a failure to obtain, or a delay in obtaining, any permit required for the Work.

c. This Consent Decree is not, and shall not be construed to be, a permit issued pursuant to any federal or state statute or regulation.

9. Notice to Successors-in-Title.

a. With respect to any property owned or controlled by the Owner Settling Defendants that is located within the Site, within 15 days after the Effective Date of this Consent Decree, the Owner Settling Defendants shall submit to EPA for review and approval a notice to be filed with the Registry of Deeds located in Polk County, Florida, which shall provide notice to all successors-in-title that the property is part of the Site, that EPA selected a remedy for the Site on September 27, 2007, and that potentially responsible parties have entered into a Consent Decree requiring implementation of the remedy. Such notices shall identify the United States District Court in which the Consent Decree was filed, the name and civil action number of this case, and the date the Consent Decree was entered by the Court. The Owner Settling Defendants shall record the notices within 10 days of EPA's approval of the notices. The Owner Settling Defendants shall provide EPA with a certified copy of the recorded notices within 10 days of recording such notices.

b. At least 30 days prior to the conveyance of any interest in property located within the Site including, but not limited to, fee interests, leasehold interests, and mortgage interests, the Owner Settling Defendant conveying the interest shall give the grantee written notice of (i) this Consent Decree, (ii) any instrument that confers a right of access to the Site (hereinafter referred to as "access easements") pursuant to Section IX (Access and Institutional Controls), and (iii) any instrument that confers a right to enforce restrictions on the use of such property (hereinafter referred to as "restrictive easements") pursuant to Section IX (Access and Institutional Controls). At least 30 days prior to such conveyance, the Owner Settling Defendant conveying the interest shall also give written notice to EPA and the State of the proposed conveyance, including the name and address of the grantee, and the date on which notice of the

Consent Decree, access easements, and/or restrictive easements was given to the grantee.

c. In the event of any such conveyance, the Owner Settling Defendants' obligations under this Consent Decree, including, but not limited to, their obligation to provide or secure access and institutional controls, as well as to abide by such institutional controls, pursuant to Section IX (Access and Institutional Controls) of this Consent Decree, shall continue to be met by the Owner Settling Defendants. In no event shall the conveyance release or otherwise affect the liability of the Owner Settling Defendants to comply with all provisions of this Consent Decree, absent the prior written consent of EPA. If the United States approves, the grantee may perform some or all of the Work under this Consent Decree.

VI. PERFORMANCE OF THE WORK BY SETTLING DEFENDANTS

10. Selection of Supervising Contractor.

a. All aspects of the Work to be performed by Settling Defendants pursuant to Sections VI (Performance of the Work by Settling Defendants), VII (Remedy Review), VIII (Quality Assurance, Sampling, and Data Analysis), and XV (Emergency Response) of this Consent Decree shall be under the direction and supervision of the Supervising Contractor, the selection of which shall be subject to disapproval by EPA. Within 10 days after the lodging of this Consent Decree, Settling Defendants shall notify EPA in writing of the name, title, and qualifications of any contractor proposed to be the Supervising Contractor. With respect to any contractor proposed to be Supervising Contractor, Settling Defendants shall demonstrate that the proposed contractor has a quality system that complies with ANSI/ASQC E4-1994, "Specifications and Guidelines for Quality Systems for Environmental Data Collection and Environmental Technology Programs," (American National Standard, January 5, 1995), by submitting a copy of the proposed contractor's Quality Management Plan ("QMP"). The QMP

should be prepared in accordance with “EPA Requirements for Quality Management Plans (QA/R-2)” (EPA/240/B-01/002, March 2001) or equivalent documentation as determined by EPA. EPA will issue a notice of disapproval or an authorization to proceed. If at any time thereafter, Settling Defendants propose to change a Supervising Contractor, Settling Defendants shall give such notice to EPA and must obtain an authorization to proceed from EPA before the new Supervising Contractor performs, directs, or supervises any Work under this Consent Decree.

b. If EPA disapproves a proposed Supervising Contractor, EPA will notify Settling Defendants in writing. Settling Defendants shall submit to EPA a list of contractors, including the qualifications of each contractor, that would be acceptable to them within 30 days of receipt of EPA’s disapproval of the contractor previously proposed. EPA will provide written notice of the names of any contractors that it disapproves and an authorization to proceed with respect to any of the other contractors. Settling Defendants may select any contractor from that list that is not disapproved and shall notify EPA of the name of the contractor selected within 21 days of EPA’s authorization to proceed.

c. If EPA fails to provide written notice of its authorization to proceed or disapproval as provided in this Paragraph and this failure prevents the Settling Defendants from meeting one or more deadlines in a plan approved by the EPA pursuant to this Consent Decree, Settling Defendants may seek relief under the provisions of Section XVIII (Force Majeure) hereof.

11. Remedial Design – Operable Unit One.

a. Within 30 days after EPA’s issuance of an authorization to proceed pursuant to Paragraph 10, Settling Defendants shall submit to EPA and the State a work plan for

the design of the Remedial Action (“Remedial Design Work Plan”) for Operable Unit One. The Remedial Design Work Plan for Operable Unit One shall provide for design of the remedy for Operable Unit One set forth in the ROD, in accordance with the SOW, and for achievement of the Performance Standards and other requirements for Operable Unit One set forth in the ROD, this Consent Decree, and/or the SOW. Upon its approval by EPA, the Remedial Design Work Plan for Operable Unit One shall be incorporated into and become enforceable under this Consent Decree. Within 30 days after EPA’s issuance of an authorization to proceed, the Settling Defendants shall also submit to EPA and the State a Health and Safety Plan for field design activities for Operable Unit One which conforms to the applicable Occupational Safety and Health Administration and EPA requirements including, but not limited to, 29 C.F.R. § 1910.120.

b. Unless otherwise directed by EPA, the Remedial Design Work Plan for Operable Unit One shall include, but not be limited to, the following: (1) a brief history of the Site; (2) a description of additional data collection and evaluation activities to be performed before the Remedial Design; (3) a design management schedule through completion of the Remedial Action Work Plan, with specific start and finish dates for design tasks and deliverables; (4) a Project Management Plan for the Remedial Design; and (5) a description of the community relations support tasks to be conducted during the Remedial Design.

c. Upon approval of the Remedial Design Work Plan for Operable Unit One by EPA and submittal of the Health and Safety Plan for all field activities for Operable Unit One to EPA and the State, Settling Defendants shall implement the Remedial Design Work Plan for Operable Unit One. The Settling Defendants shall submit to EPA and the State all plans, submittals and other deliverables required under the approved Remedial Design Work Plan for

Operable Unit One in accordance with the approved schedule for review and approval pursuant to Section XI (EPA Approval of Plans and Other Submissions). Unless otherwise directed by EPA, Settling Defendants shall not commence Remedial Design activities at the Site prior to approval of the Remedial Design Work Plan for Operable Unit One.

d. Unless otherwise directed by EPA, the draft Remedial Design submittal for Operable Unit One shall include, at a minimum, the following: (1) design criteria; (2) plans, drawings, and specifications; (3) a plan for the implementation of institutional controls; (4) a sampling and analysis report which shall present the results of any additional pre-design field sampling and pre-design work; (5) a Field Sampling Plan (directed at future sampling for measuring progress towards meeting Performance Standards) and a Quality Assurance Project Plan; (6) a construction schedule; and (7) a construction cost estimate.

12. Remedial Action – Operable Unit One.

a. Within 60 days after the approval of the final Remedial Design submittal for Operable Unit One, Settling Defendants shall submit to EPA and the State a work plan for the performance of the Remedial Action (“Remedial Action Work Plan”) for Operable Unit One. The Remedial Action Work Plan for Operable Unit One shall provide for construction and implementation of the remedy for Operable Unit One set forth in the ROD and achievement of the Performance Standards for Operable Unit One, in accordance with this Consent Decree, the ROD, the SOW, and the design plans and specifications developed in accordance with the Remedial Design Work Plan for Operable Unit One and approved by EPA. Upon its approval by EPA, the Remedial Action Work Plan for Operable Unit One shall be incorporated into and become enforceable under this Consent Decree. At the same time as they submit the Remedial Action Work Plan for Operable Unit One, Settling Defendants shall submit to EPA and the State

a Health and Safety Plan for field activities required by the Remedial Action Work Plan for Operable Unit One which conforms to the applicable Occupational Safety and Health Administration and EPA requirements including, but not limited to, 29 C.F.R. § 1910.120.

b. Unless otherwise directed by EPA, the Remedial Action Work Plan for Operable Unit One shall include the following: (1) a detailed description of the tasks to be performed and a description of the work products to be submitted to EPA; (2) a schedule for developing and submitting other required Remedial Action plans; (3) a Project Management Plan for the Remedial Action, including provisions for quarterly reports to EPA; and (4) a description of the community relations support activities to be conducted during the Remedial Action.

Unless otherwise directed by EPA, the Remedial Action Work Plan for Operable Unit One also shall include a schedule for the development and implementation of a Project Delivery Strategy and a Construction Management Plan. The schedule shall also account for a Construction Quality Assurance Project Plan, which shall detail the approach to quality assurance during construction activities at the Site and shall specify a quality assurance official, independent of the Supervising Contractor, to conduct a quality assurance program during the construction phase of the project.

c. Upon approval of the Remedial Action Work Plan for Operable Unit One by EPA, Settling Defendants shall implement the activities required under the Remedial Action Work Plan for Operable Unit One. The Settling Defendants shall submit to EPA and the State all plans, submittals, or other deliverables required under the approved Remedial Action Work Plan for Operable Unit One in accordance with the approved schedule for review and approval pursuant to Section XI (EPA Approval of Plans and Other Submissions). Unless otherwise directed by EPA, Settling Defendants shall not commence physical Remedial Action activities at

the Site prior to approval of the Remedial Action Work Plan for Operable Unit One.

13. The Settling Defendants shall continue to implement the Remedial Action and O&M for Operable Unit One until the Performance Standards for Operable Unit One are achieved and for so long thereafter as is otherwise required under this Consent Decree.

14. Remedial Design – Operable Unit Two.

a. Within 30 days after EPA notifies Settling Defendants that the Work on Operable Unit One is complete, Settling Defendants shall submit to EPA and the State a Remedial Design Work Plan for Operable Unit Two. The Remedial Design Work Plan for Operable Unit Two shall provide for design of the remedy for Operable Unit Two set forth in the ROD, in accordance with the SOW, and for achievement of the requirements for Operable Unit Two set forth in the ROD, this Consent Decree, and/or the SOW. Upon its approval by EPA, the Remedial Design Work Plan for Operable Unit Two shall be incorporated into and become enforceable under this Consent Decree. Within 30 days after EPA notifies Settling Defendants that the Work on Operable Unit One is complete, the Settling Defendants shall also submit to EPA and the State a Health and Safety Plan for field design activities for Operable Unit Two which conforms to the applicable Occupational Safety and Health Administration and EPA requirements including, but not limited to, 29 C.F.R. § 1910.120.

b. Unless otherwise directed by EPA, the Remedial Design Work Plan for Operable Unit Two shall include, but not be limited to, the following: (1) a brief history of the Site; (2) a treatability study work plan; (3) a description of additional data collection and evaluation activities to be performed before the Remedial Design; (4) a design management schedule through completion of the Remedial Action Work Plan, with specific start and finish dates for design tasks and deliverables; (5) a Project Management Plan for the Remedial Design;

and (6) a description of the community relations support tasks to be conducted during the Remedial Design.

c. Upon approval of the Remedial Design Work Plan for Operable Unit Two by EPA and submittal of the Health and Safety Plan for all field activities for Operable Unit Two to EPA and the State, Settling Defendants shall implement the Remedial Design Work Plan for Operable Unit Two. The Settling Defendants shall submit to EPA and the State all plans, submittals and other deliverables required under the approved Remedial Design Work Plan for Operable Unit Two in accordance with the approved schedule for review and approval pursuant to Section XI (EPA Approval of Plans and Other Submissions). Unless otherwise directed by EPA, Settling Defendants shall not commence Remedial Design activities with respect to Operable Unit Two prior to approval of the Remedial Design Work Plan for Operable Unit Two.

d. Unless otherwise directed by EPA, the draft Remedial Design submittal for Operable Unit Two shall include, at a minimum, the following: (1) design criteria; (2) plans, drawings, and specifications; (3) results of treatability studies and other pre-design data collection and evaluation activities; (4) a plan for the implementation of institutional controls; (5) an updated Groundwater Monitoring Plan; (6) a sampling and analysis plan which shall include the results of any additional field sampling and pre-design work, a Field Sampling Plan (directed at future sampling for measuring progress towards meeting Performance Standards), and a Quality Assurance Project Plan; (7) a construction schedule; and (8) a construction cost estimate.

15. Remedial Action – Operable Unit Two.

a. Within 60 days after the approval of the final design submittal for Operable Unit Two, Settling Defendants shall submit to EPA and the State a Remedial Action Work Plan for Operable Unit Two. The Remedial Action Work Plan for Operable Unit Two

shall provide for construction and implementation of the remedy for Operable Unit Two set forth in the ROD, in accordance with this Consent Decree, the ROD, the SOW, and the design plans and specifications developed in accordance with the Remedial Design Work Plan for Operable Unit Two and approved by EPA. Upon its approval by EPA, the Remedial Action Work Plan for Operable Unit Two shall be incorporated into and become enforceable under this Consent Decree. At the same time as they submit the Remedial Action Work Plan for Operable Unit Two, Settling Defendants shall submit to EPA and the State a Health and Safety Plan for field activities required by the Remedial Action Work Plan for Operable Unit Two which conforms to the applicable Occupational Safety and Health Administration and EPA requirements including, but not limited to, 29 C.F.R. § 1910.120.

b. Unless otherwise directed by EPA, the Remedial Action Work Plan for Operable Unit Two shall include the following: (1) a detailed description of the tasks to be performed and a description of the work products to be submitted to EPA; (2) a schedule for developing and submitting other required Remedial Action plans; (3) a Project Management Plan for the Remedial Action, including provisions for quarterly reports to EPA; and (4) a description of the community relations support activities to be conducted during the Remedial Action.

Unless otherwise directed by EPA, the Remedial Action Work Plan for Operable Unit Two also shall include a schedule for the development and implementation of a Project Delivery Strategy and a Construction Management Plan. The schedule shall also account for a Construction Quality Assurance Project Plan, which shall detail the approach to quality assurance during construction activities at the Site and shall specify a quality assurance official, independent of the Supervising Contractor, to conduct a quality assurance program during the construction phase of the project.

c. Upon approval of the Remedial Action Work Plan for Operable Unit Two by EPA, Settling Defendants shall implement the activities required under the Remedial Action Work Plan for Operable Unit Two. The Settling Defendants shall submit to EPA and the State all plans, submittals, or other deliverables required under the approved Remedial Action Work Plan for Operable Unit Two in accordance with the approved schedule for review and approval pursuant to Section XI (EPA Approval of Plans and Other Submissions). Unless otherwise directed by EPA, Settling Defendants shall not commence physical Remedial Action activities with respect to Operable Unit Two prior to approval of the Remedial Action Work Plan for Operable Unit Two.

16. The Settling Defendants shall continue to implement the Remedial Action and O&M for Operable Unit Two for so long as is required under this Consent Decree or until EPA's selection of a final remedy for Operable Unit Two.

17. Modification of the SOW or Related Work Plans.

a. If EPA determines that modification to the work specified in the SOW and/or in work plans developed pursuant to the SOW is necessary to achieve and maintain the Performance Standards or to carry out and maintain the effectiveness of the remedy set forth in the ROD, EPA may require that such modification be incorporated in the SOW and/or such work plans, provided, however, that a modification may only be required pursuant to this Paragraph to the extent that it is consistent with the scope of the remedy selected in the ROD.

b. For the purposes of this Paragraph and Paragraph 55 only, the "scope of the remedy selected in the ROD" is the work necessary for the effective implementation of the Landia Chemical Company Site selected remedy as set forth in the Landia Chemical Company Site ROD. Specifically, the remedy includes:

(1) Excavation and off-site disposal of impacted soil, a limited amount of which constitutes threats for unacceptable exposure to, and/or migration of, chemicals of concern;

(2) Institutional Controls to prevent exposure to contaminants including groundwater use restrictions and restrictive covenants for the Site property; and

(3) An interim action to treat the area's groundwater which has been most impacted by site-related contaminants. This interim action shall consist of in-situ chemical oxidation treatment in source areas to address the highest contaminant concentrations and in-situ bioremediation in selected source areas to enhance the natural attenuation process. This interim action shall be implemented within the boundary of the Site north of Olive Street and shall be further refined during the Remedial Design phase. A Groundwater Monitoring Plan shall be developed to evaluate the effectiveness of the soil remedy and the groundwater interim action on groundwater contaminant concentrations.

In order to ensure the effective implementation and long term integrity of the selected remedy, confirmation sampling in the excavated areas and regular sampling of the groundwater will be necessary. The "scope of the remedy selected in the ROD" shall include necessary and appropriate adjustments, measures or actions to ensure the effectiveness of the remedy.

c. If Settling Defendants object to any modification determined by EPA to be necessary pursuant to this Paragraph, they may seek dispute resolution pursuant to Section XIX (Dispute Resolution), Paragraph 71 (record review). The SOW and/or related work plans shall be modified in accordance with final resolution of the dispute.

d. Settling Defendants shall implement any work required by any modifications incorporated in the SOW and/or in work plans developed pursuant to the SOW in

accordance with this Paragraph.

e. Nothing in this Paragraph shall be construed to limit EPA's authority to require performance of further response actions as otherwise provided in this Consent Decree.

18. Settling Defendants acknowledge and agree that nothing in this Consent Decree, the SOW, or the Remedial Design or Remedial Action Work Plans constitutes a warranty or representation of any kind by Plaintiff that compliance with the work requirements set forth in the SOW and the Work Plans will achieve the Performance Standards.

19. a. Settling Defendants shall, prior to any off-Site shipment of Waste Material from the Site to an out-of-state waste management facility, provide written notification to the appropriate state environmental official in the receiving facility's state and to the EPA Project Coordinator of such shipment of Waste Material. However, this notification requirement shall not apply to any off-Site shipments when the total volume of all such shipments will not exceed 10 cubic yards.

(1) The Settling Defendants shall include in the written notification the following information, where available: (i) the name and location of the facility to which the Waste Material is to be shipped; (ii) the type and quantity of the Waste Material to be shipped; (iii) the expected schedule for the shipment of the Waste Material; and (iv) the method of transportation. The Settling Defendants shall notify the state in which the planned receiving facility is located of major changes in the shipment plan, such as a decision to ship the Waste Material to another facility within the same state, or to a facility in another state.

(2) The identity of the receiving facility and state will be determined by the Settling Defendants following the award of the contract for Remedial Action construction. The Settling Defendants shall provide the information required by Paragraph 19(a) as soon as

practicable after the award of the contract and before the Waste Material is actually shipped.

b. Before shipping any hazardous substances, pollutants, or contaminants from the Site to an off-site location, Settling Defendants shall obtain EPA's certification that the proposed receiving facility is operating in compliance with the requirements of CERCLA Section 121(d)(3) and 40 C.F.R. § 300.440. Settling Defendants shall only send hazardous substances, pollutants, or contaminants from the Site to an off-site facility that complies with the requirements of the statutory provision and regulations cited in the preceding sentence.

VII. REMEDY REVIEW

20. Periodic Review. Settling Defendants shall conduct any studies and investigations as requested by EPA, in order to permit EPA to conduct reviews of whether the Remedial Action is protective of human health and the environment at least every five years as required by Section 121(c) of CERCLA and any applicable regulations.

21. EPA Selection of Further Response Actions. If EPA determines, at any time, that the Remedial Action is not protective of human health and the environment, EPA may select further response actions for the Site in accordance with the requirements of CERCLA and the NCP.

22. Opportunity to Comment. Settling Defendants and, if required by Sections 113(k)(2) or 117 of CERCLA, the public will be provided with an opportunity to comment on any further response actions proposed by EPA as a result of the review conducted pursuant to Section 121(c) of CERCLA and to submit written comments for the record during the comment period.

23. Settling Defendants' Obligation to Perform Further Response Actions. If EPA selects further response actions for the Site, the Settling Defendants shall undertake such further

response actions. Settling Defendants may invoke the procedures set forth in Section XIX (Dispute Resolution) to dispute (1) EPA's determination that the Remedial Action is not protective of human health and the environment, or (2) EPA's selection of the further response actions. Disputes pertaining to the whether the Remedial Action is protective or to EPA's selection of further response actions shall be resolved pursuant to Paragraph 71 (record review).

24. Submissions of Plans. If Settling Defendants are required to perform further response actions pursuant to Paragraph 23, they shall submit a plan for such work to EPA for approval in accordance with the procedures set forth in Section VI (Performance of the Work by Settling Defendants) and shall implement the plan approved by EPA in accordance with the provisions of this Decree.

VIII. QUALITY ASSURANCE, SAMPLING, AND DATA ANALYSIS

25. Settling Defendants shall use quality assurance, quality control, and chain of custody procedures for all design, compliance and monitoring samples in accordance with "EPA Requirements for Quality Assurance Project Plans (QA/R5)" (EPA/240/B-01/003, March 2001); "Guidance for Quality Assurance Project Plans (QA/G-5)" (EPA/240/R-02/009, December 2002), and subsequent amendments. The most recent version of these and other documents related to EPA's Quality System for Environmental Data and Technology can be found at: <http://www.epa.gov/quality/>. Amended guidelines shall apply only to procedures conducted after the effective date of any amendments. Prior to the commencement of any monitoring project under this Consent Decree, Settling Defendants shall submit to EPA for approval, after a reasonable opportunity for review and comment by the State, a Quality Assurance Project Plan ("QAPP") that is consistent with the SOW, the NCP and applicable guidance documents. If relevant to the proceeding, the Parties agree that validated sampling data generated in accordance

with the QAPP(s) and reviewed and approved by EPA shall be admissible as evidence, without objection, in any proceeding under this Decree. Settling Defendants shall ensure that EPA and State personnel and their authorized representatives are allowed access at reasonable times to all laboratories utilized by Settling Defendants in implementing this Consent Decree. In addition, Settling Defendants shall ensure that such laboratories shall analyze all samples submitted by EPA pursuant to the QAPP for quality assurance monitoring. Settling Defendants shall ensure that the laboratories they utilize for the analysis of samples taken pursuant to this Decree perform all analyses according to accepted EPA methods. Accepted EPA methods consist of those methods which are documented in the most recent "Contract Lab Program Statement of Work for Inorganic Analysis" and the "Contract Lab Program Statement of Work for Organic Analysis." The most recent version of these documents can be found at:

<http://www.epa.gov/superfund/programs/clp/>. However, upon approval by EPA, Settling Defendants may use other analytical methods which are as stringent as or more stringent than the CLP-approved methods. Settling Defendants shall ensure that all laboratories they use for analysis of samples taken pursuant to this Consent Decree participate in an EPA or EPA-equivalent QA/QC program. Settling Defendants shall only use laboratories that have a documented Quality System which complies with ANSI/ASQC E4-1994, "Specifications and Guidelines for Quality Systems for Environmental Data Collection and Environmental Technology Programs," (American National Standard, January 5, 1995), and "EPA Requirements for Quality Management Plans (QA/R-2)," (EPA/240/B-01/002, March 2001) or equivalent documentation as determined by EPA. EPA may consider laboratories accredited under the National Environmental Laboratory Accreditation Program as meeting the Quality System requirements. Settling Defendants shall ensure that all field methodologies utilized in

collecting samples for subsequent analysis pursuant to this Decree will be conducted in accordance with the procedures set forth in the QAPP approved by EPA.

26. Upon request, the Settling Defendants shall allow split or duplicate samples to be taken by EPA or its authorized representative. Settling Defendants shall notify EPA not less than 14 days in advance of any sample collection activity unless shorter notice is agreed to by EPA. In addition, EPA shall have the right to take any additional samples that EPA deems necessary. Upon request, EPA shall allow the Settling Defendants to take split or duplicate samples of any samples it takes as part of the Plaintiff's oversight of the Settling Defendants' implementation of the Work.

27. Settling Defendants shall submit to EPA 3 copies and to the State 2 copies of the results of all sampling and/or tests or other data obtained or generated by or on behalf of Settling Defendants with respect to the Site and/or the implementation of this Consent Decree unless EPA agrees otherwise.

28. Notwithstanding any provision of this Consent Decree, the United States hereby retains all of its information gathering and inspection authorities and rights, including enforcement actions related thereto, under CERCLA, RCRA and any other applicable statutes or regulations.

IX. ACCESS AND INSTITUTIONAL CONTROLS

29. If the Site, or any other property where access and/or land/water use restrictions are needed to implement this Consent Decree, is owned or controlled by any of the Settling Defendants, such Settling Defendants shall:

a. commencing on the date of lodging of this Consent Decree, provide the United States, the State, and their representatives, including EPA and its contractors, with access

at all reasonable times to those portions of the Site owned by the Owner Settling Defendants, or such other property, for the purpose of conducting any activity related to this Consent Decree including, but not limited to, the following activities:

- (1) Monitoring the Work;
- (2) Verifying any data or information submitted to the United States or the State;
- (3) Conducting investigations relating to contamination at or near the Site;
- (4) Obtaining samples;
- (5) Assessing the need for, planning, or implementing additional response actions at or near the Site;
- (6) Assessing implementation of quality assurance and quality control practices as defined in the approved Quality Assurance Project Plans;
- (7) Implementing the Work pursuant to the conditions set forth in Paragraph 88 of this Consent Decree;
- (8) Inspecting and copying records, operating logs, contracts, or other documents maintained or generated by Settling Defendants or their agents, consistent with Section XXIV (Access to Information);
- (9) Assessing Settling Defendants' compliance with this Consent Decree; and
- (10) Determining whether the Site or other property is being used in a manner that is prohibited or restricted, or that may need to be prohibited or restricted, by or pursuant to this Consent Decree;

b. commencing on the date of lodging of this Consent Decree, refrain from using the portions of the Site owned by the Owner Settling Defendants, or such other property, in any manner that would interfere with or adversely affect the implementation, integrity, or protectiveness of the remedial measures to be performed pursuant to this Consent Decree. Such restrictions include, but are not limited to:

(1) Restricting the use of contaminated groundwater until drinking water standards are met. Detections of site-related contaminants are present in groundwater of the surficial aquifer both on-site and off-site at levels above drinking water standards.

(2) Limiting the future use of the Landia and former Florida Favorite Fertilizer properties to industrial. The cleanup goals for soil on these two properties were developed assuming the use of the properties remains industrial.

(3) Protecting the integrity of on-site engineering controls. Certain structures including buildings, concrete slabs, and pavement on the Site currently prevent exposure to contaminated soil underneath.

c. execute and record in the Public Records of Polk County, Florida restrictive covenants, running with the land, that grant a right of access for the purpose of conducting any activity related to this Consent Decree including, but not limited to, those activities listed in Paragraph 29(a) of this Consent Decree, and that impose the land/water use restrictions listed in Paragraph 29(b) of this Consent Decree on the Site, or other restrictions that EPA determines are necessary to implement, ensure non-interference with, or ensure the protectiveness of the remedial measures to be performed pursuant to this Consent Decree. Such Settling Defendants shall, within 45 days after the Effective Date of this Consent Decree, submit to EPA for review and approval with respect to such property:

(1) draft restrictive covenants, in substantially the form attached hereto as Appendix D, that are enforceable under the laws of the State of Florida; and

(2) a current Title Ownership and Encumbrance Report issued by a national title insurance company acceptable to EPA (“O&E Report”) or some other evidence of title acceptable to EPA, which shows title to the land described in the restrictive covenants to be free and clear of all prior liens and encumbrances (except when those liens or encumbrances are approved by EPA or when, despite best efforts, Owner Settling Defendants are unable to obtain release or subordination of such prior liens or encumbrances).

Within 15 days of EPA’s approval and acceptance of the restrictive covenants and the title evidence, such Owner Settling Defendants shall update the title search and, if it is determined that nothing has occurred since the date of submission of the O&E Report to affect the title adversely, record the restrictive covenants in the Public Records of Polk County, Florida. Within 30 days of recording the restrictive covenants, Owner Settling Defendants shall provide EPA with a current O&E Report, or other final evidence of title acceptable to EPA, and a certified copy of the original recorded restrictive covenants showing the clerk’s recording stamps.

30. If the Site, or any other property where access and/or land use restrictions are needed to implement this Consent Decree, is owned or controlled by persons other than any of the Settling Defendants, Settling Defendants shall use best efforts to secure from such persons:

a. an agreement to provide access thereto for Settling Defendants, as well as for the United States on behalf of EPA, and the State, as well as their representatives (including contractors), for the purpose of conducting any activity related to this Consent Decree including, but not limited to, those activities listed in Paragraph 29(a) of this Consent Decree;

b. an agreement, enforceable by the Settling Defendants and the United

States, to refrain from using the Site, or such other property, in any manner that would interfere with or adversely affect the implementation, integrity, or protectiveness of the remedial measures to be performed pursuant to this Consent Decree. Such restrictions include, but are not limited to, the restrictions in Paragraph 29(b).

31. For purposes of Paragraphs 29 and 30 of this Consent Decree, "best efforts" includes the payment of reasonable sums of money in consideration of access, access easements, land/water use restrictions, restrictive easements, and/or an agreement to release or subordinate a prior lien or encumbrance. If (a) any access or land/water use restriction agreements required by Paragraphs 30(a) or 30(b) of this Consent Decree are not obtained within 45 days after the Effective Date, or (b) Settling Defendants are unable to obtain an agreement pursuant to Paragraph 29(c)(1) from the holder of a prior lien or encumbrance to release or subordinate such lien or encumbrance to the easement being created pursuant to this consent decree within 45 days after the Effective Date, Settling Defendants shall promptly notify the United States in writing, and shall include in that notification a summary of the steps that Settling Defendants have taken to attempt to comply with Paragraph 29 or 30 of this Consent Decree. The United States may, as it deems appropriate, assist Settling Defendants in obtaining access or land/water use restrictions, either in the form of contractual agreements or in the form of easements running with the land, or in obtaining the release or subordination of a prior lien or encumbrance. Settling Defendants shall reimburse the United States in accordance with the procedures in Section XVI (Payments for Response Costs), for all costs incurred, direct or indirect, by the United States in obtaining such access, land/water use restrictions, and/or the release/subordination of prior liens or encumbrances including, but not limited to, the cost of attorney time and the amount of monetary consideration paid or just compensation.

32. EPA has determined that the regulatory controls of the Southwest Florida Water Management District contain ground water use restrictions sufficient to implement the remedy selected in the ROD, ensure the integrity and protectiveness thereof, or ensure non-interference therewith. To utilize such regulatory controls, EPA and the Southwest Florida Water Management District executed a Memorandum of Agreement dated September 11, 2008. The MOA is attached as Appendix E to this Consent Decree.

33. Notwithstanding any provision of this Consent Decree, the United States retains all of its access authorities and rights, as well as all of its rights to require land/water use restrictions, including enforcement authorities related thereto, under CERCLA, RCRA and any other applicable statute or regulations.

X. REPORTING REQUIREMENTS

34. In addition to any other requirement of this Consent Decree, Settling Defendants shall submit to EPA 1 copy and the State 1 copy of written quarterly progress reports that:

- (a) describe the actions which have been taken toward achieving compliance with this Consent Decree during the previous quarter;
- (b) include a summary of all results of sampling and tests and all other data received or generated by Settling Defendants or their contractors or agents in the previous quarter;
- (c) identify all work plans, plans and other deliverables required by this Consent Decree completed and submitted during the previous quarter;
- (d) describe all actions, including, but not limited to, data collection and implementation of work plans, which are scheduled for the next quarter and provide other information relating to the progress of construction, including, but not limited to, critical path diagrams, Gantt charts and Pert charts;
- (e) include information regarding percentage of completion, unresolved delays encountered or anticipated that may affect the future schedule for implementation of the Work, and a description

of efforts made to mitigate those delays or anticipated delays; (f) include any modifications to the work plans or other schedules that Settling Defendants have proposed to EPA or that have been approved by EPA; and (g) describe all activities undertaken in support of the Community Relations Plan during the previous quarter and those to be undertaken in the next quarter.

Settling Defendants shall submit these progress reports to EPA and the State by the tenth day of every month following the subject quarter, beginning with the lodging of this Consent Decree until EPA notifies the Settling Defendants pursuant to Paragraph 55(b) of Section XIV (Certification of Completion). If requested by EPA, Settling Defendants shall also provide briefings for EPA and the State to discuss the progress of the Work.

35. The Settling Defendants shall notify EPA of any change in the schedule described in the quarterly progress report for the performance of any activity, including, but not limited to, data collection and implementation of work plans, no later than seven days prior to the performance of the activity.

36. Upon the occurrence of any event during performance of the Work that Settling Defendants are required to report pursuant to Section 103 of CERCLA or Section 304 of the Emergency Planning and Community Right-to-Know Act ("EPCRA"), Settling Defendants shall within 24 hours of the onset of such event orally notify the EPA Project Coordinator or the Alternate EPA Project Coordinator (in the event of the unavailability of the EPA Project Coordinator), or, in the event that neither the EPA Project Coordinator or Alternate EPA Project Coordinator is available, the Emergency Response Section, Region 4, United States Environmental Protection Agency. These reporting requirements are in addition to the reporting required by CERCLA Section 103 or EPCRA Section 304.

37. Within 20 days of the onset of such an event, Settling Defendants shall furnish to

Plaintiff a written report, signed by the Settling Defendants' Project Coordinator, setting forth the events which occurred and the measures taken, and to be taken, in response thereto. Within 30 days of the conclusion of such an event, Settling Defendants shall submit a report setting forth all actions taken in response thereto.

38. Settling Defendants shall submit 3 copies of all plans, reports, and data required by the SOW, the Remedial Design Work Plan, the Remedial Action Work Plan, or any other approved plans to EPA in accordance with the schedules set forth in such plans. Settling Defendants shall simultaneously submit 2 copies of all such plans, reports and data to the State. Upon request by EPA Settling Defendants shall submit in electronic form all portions of any report or other deliverable Settling Defendants are required to submit pursuant to the provisions of this Consent Decree.

39. All reports and other documents submitted by Settling Defendants to EPA other than the quarterly progress reports referred to above which purport to document Settling Defendants' compliance with the terms of this Consent Decree shall be signed by an authorized representative of the Settling Defendants.

XI. EPA APPROVAL OF PLANS AND OTHER SUBMISSIONS

40. After review of any plan, report or other item which is required to be submitted for approval pursuant to this Consent Decree, EPA, after reasonable opportunity for review and comment by the State, shall: (a) approve, in whole or in part, the submission; (b) approve the submission upon specified conditions; (c) modify the submission to cure the deficiencies; (d) disapprove, in whole or in part, the submission, directing that the Settling Defendants modify the submission; or (e) any combination of the above. However, EPA shall not modify a submission without first providing Settling Defendants at least one notice of deficiency and an

opportunity to cure within 30 days, except where to do so would cause serious disruption to the Work or where previous submission(s) have been disapproved due to material defects and the deficiencies in the submission under consideration indicate a bad faith lack of effort to submit an acceptable deliverable.

41. In the event of approval, approval upon conditions, or modification by EPA, pursuant to Paragraph 40(a), (b), or (c), Settling Defendants shall proceed to take any action required by the plan, report, or other item, as approved or modified by EPA subject only to their right to invoke the Dispute Resolution procedures set forth in Section XIX (Dispute Resolution) with respect to the modifications or conditions made by EPA. In the event that EPA modifies the submission to cure the deficiencies pursuant to Paragraph 40(c) and the submission has a material defect, EPA retains its right to seek stipulated penalties, as provided in Section XX (Stipulated Penalties).

42. Resubmission of Plans.

a. Upon receipt of a notice of disapproval pursuant to Paragraph 40(d), Settling Defendants shall, within 30 days or such longer time as specified by EPA in such notice, correct the deficiencies and resubmit the plan, report, or other item for approval. Any stipulated penalties applicable to the submission, as provided in Section XX, shall accrue during the 30-day period or otherwise specified period but shall not be payable unless the resubmission is disapproved or modified due to a material defect as provided in Paragraphs 43 and 44.

b. Notwithstanding the receipt of a notice of disapproval pursuant to Paragraph 40(d), Settling Defendants shall proceed, at the direction of EPA, to take any action required by any non-deficient portion of the submission. Implementation of any non-deficient portion of a submission shall not relieve Settling Defendants of any liability for stipulated

penalties under Section XX (Stipulated Penalties).

43. In the event that a resubmitted plan, report or other item, or portion thereof, is disapproved by EPA, EPA may again require the Settling Defendants to correct the deficiencies, in accordance with the preceding Paragraphs. EPA also retains the right to modify or develop the plan, report or other item. Settling Defendants shall implement any such plan, report, or item as modified or developed by EPA, subject only to their right to invoke the procedures set forth in Section XIX (Dispute Resolution).

44. If upon resubmission, a plan, report, or item is disapproved or modified by EPA due to a material defect, Settling Defendants shall be deemed to have failed to submit such plan, report, or item timely and adequately unless the Settling Defendants invoke the dispute resolution procedures set forth in Section XIX (Dispute Resolution) and EPA's action is overturned pursuant to that Section. The provisions of Section XIX (Dispute Resolution) and Section XX (Stipulated Penalties) shall govern the implementation of the Work and accrual and payment of any stipulated penalties during Dispute Resolution. If EPA's disapproval or modification is upheld, stipulated penalties shall accrue for such violation from the date on which the initial submission was originally required, as provided in Section XX.

45. All plans, reports, and other items required to be submitted to EPA under this Consent Decree shall, upon approval or modification by EPA, be enforceable under this Consent Decree. In the event EPA approves or modifies a portion of a plan, report, or other item required to be submitted to EPA under this Consent Decree, the approved or modified portion shall be enforceable under this Consent Decree.

XII. PROJECT COORDINATORS

46. Within 20 days of lodging this Consent Decree, Settling Defendants and EPA will

notify each other, in writing, of the name, address and telephone number of their respective designated Project Coordinators and Alternate Project Coordinators. If a Project Coordinator or Alternate Project Coordinator initially designated is changed, the identity of the successor will be given to the other Parties at least 5 working days before the changes occur, unless impracticable, but in no event later than the actual day the change is made. The Settling Defendants' Project Coordinator shall be subject to disapproval by EPA and shall have the technical expertise sufficient to adequately oversee all aspects of the Work. The Settling Defendants' Project Coordinator shall not be an attorney for any of the Settling Defendants in this matter. He or she may assign other representatives, including other contractors, to serve as a Site representative for oversight of performance of daily operations during remedial activities.

47. Plaintiff may designate other representatives, including, but not limited to, EPA and State employees, and federal and State contractors and consultants, to observe and monitor the progress of any activity undertaken pursuant to this Consent Decree. EPA's Project Coordinator and Alternate Project Coordinator shall have the authority lawfully vested in a Remedial Project Manager and an On-Scene Coordinator by the National Contingency Plan, 40 C.F.R. Part 300. In addition, EPA's Project Coordinator or Alternate Project Coordinator shall have authority, consistent with the National Contingency Plan, to halt any Work required by this Consent Decree and to take any necessary response action when s/he determines that conditions at the Site constitute an emergency situation or may present an immediate threat to public health or welfare or the environment due to release or threatened release of Waste Material.

48. EPA's Project Coordinator and the Settling Defendants' Project Coordinator will meet periodically as requested by EPA.

XIII. PERFORMANCE GUARANTEE

49. In order to ensure the full and final completion of the Work, PCS JV, Agrico and BASF on behalf of the Settling Defendants shall establish and maintain a Performance Guarantee for the benefit of EPA in the amount of \$8,500,000 (hereinafter "Estimated Cost of the Work") in one or more of the following forms, which must be satisfactory in form and substance to EPA:

a. A surety bond unconditionally guaranteeing payment and/or performance of the Work that is issued by a surety company among those listed as acceptable sureties on Federal bonds as set forth in Circular 570 of the U.S. Department of the Treasury;

b. One or more irrevocable letters of credit, payable to or at the direction of EPA, that is issued by one or more financial institution(s) (i) that has the authority to issue letters of credit and (ii) whose letter-of-credit operations are regulated and examined by a U.S. Federal or State agency;

c. A trust fund established for the benefit of EPA that is administered by a trustee (i) that has the authority to act as a trustee and (ii) whose trust operations are regulated and examined by a U.S. Federal or State agency;

d. A policy of insurance that (i) provides EPA with acceptable rights as a beneficiary thereof; and (ii) is issued by an insurance carrier (a) that has the authority to issue insurance policies in the applicable jurisdiction(s) and (b) whose insurance operations are regulated and examined by a State agency;

e. A demonstration by PCS JV, Agrico and BASF that each such Settling Defendant meets the financial test criteria of 40 C.F.R. § 264.143(f) with respect to the Estimated Cost of the Work, provided that all other requirements of 40 C.F.R. § 264.143(f) are satisfied; or

f. A written guarantee to fund or perform the Work executed in favor of EPA by: (i) a direct or indirect parent company of PCS JV, Agrico and BASF on behalf of each such Settling Defendant, or (ii) a company that has a “substantial business relationship” (as defined in 40 C.F.R. § 264.141(h)) with PCS JV, Agrico and BASF on behalf of each such Settling Defendant; provided, however, that any company providing such a guarantee must demonstrate to the satisfaction of EPA that it satisfies the financial test requirements of 40 C.F.R. § 264.143(f) with respect to the Estimated Cost of the Work.

50. PCS JV, Agrico, and BASF, on behalf of the Settling Defendants, have selected, and EPA has approved, as initial Performance Guarantees, in the forms attached hereto as Appendix F: (a) a written guarantee to fund or perform the work pursuant to Paragraph 49(f) on behalf of PCS JV; (b) a written guarantee to fund or perform the work pursuant to Paragraph 49(f) on behalf of Agrico; and (c) an irrevocable letter of credit pursuant to Paragraph 49(b) on behalf of BASF. Within ten days after the Effective Date of this Consent Decree, PCS JV, Agrico, and BASF, on behalf of the Settling Defendants, shall execute or otherwise finalize all instruments or other documents required in order to make the selected Performance Guarantees legally binding in a form substantially identical to the documents attached hereto as Appendix F, and such Performance Guarantees shall thereupon be fully effective. Within 60 days after the Effective Date, PCS JV, Agrico, and BASF, on behalf of the Settling Defendants, shall submit all executed and/or otherwise finalized instruments or other documents required in order to make the selected Performance Guarantees legally binding to the EPA Regional Financial Management Officer in accordance with Section XXVI (“Notices and Submissions”) of this Consent Decree, with a copy to Deborah H. Jourdan, Superfund Records Manager, Region 4, U.S. Environmental Protection Agency, Atlanta Federal Center, 61 Forsyth Street, Atlanta,

Georgia 30303-8960 and to the United States and EPA as specified in Section XXVI.

51. If at any time during the effective period of this Consent Decree, a Settling Defendant provides a Performance Guarantee for completion of the Work by means of a demonstration or guarantee pursuant to Paragraph 49(e) or Paragraph 49(f) above, such Settling Defendant shall also comply with the other relevant requirements of 40 C.F.R. § 264.143(f), 40 C.F.R. § 264.151(f), and 40 C.F.R. § 264.151(h)(1) relating to these methods unless otherwise provided in this Consent Decree, including but not limited to (i) the initial submission of required financial reports and statements from the relevant entity's chief financial officer and independent certified public accountant; (ii) the annual re-submission of such reports and statements within ninety days after the close of each such entity's fiscal year; and (iii) the notification of EPA within ninety days after the close of any fiscal year in which such entity no longer satisfies the financial test requirements set forth at 40 C.F.R. § 264.143(f)(1). For purposes of the Performance Guarantee methods specified in this Section XIII, references in 40 C.F.R. Part 264, Subpart H, to "closure," "post-closure," and "plugging and abandonment" shall be deemed to refer to the Work required under this Consent Decree, and the terms "current closure cost estimate" "current post-closure cost estimate," and "current plugging and abandonment cost estimate" shall be deemed to refer to the Estimated Cost of the Work.

52. In the event that EPA determines at any time that a Performance Guarantee provided by any Settling Defendant pursuant to this Section is inadequate or otherwise no longer satisfies the requirements set forth in this Section (e.g., due to an increase in the estimated cost of completing the Work), or in the event that any Settling Defendant becomes aware of information indicating that a Performance Guarantee provided pursuant to this Section is inadequate or otherwise no longer satisfies the requirements set forth in this Section (e.g., due to an increase in

the estimated cost of completing the Work), Settling Defendant, within 30 days of receipt of notice of EPA's determination or, as the case may be, within 30 days of any Settling Defendant becoming aware of such information, shall obtain and present to EPA for approval a proposal for a revised or alternative form of Performance Guarantee listed in Paragraph 49 of this Consent Decree that satisfies all requirements set forth in this Section XIII. In seeking approval for a revised or alternative form of Performance Guarantee, Settling Defendants shall follow the procedures set forth in Paragraph 54(b)(2) of this Consent Decree. Settling Defendants' inability to post a Performance Guarantee for completion of the Work shall in no way excuse performance of any other requirements of this Consent Decree, including, without limitation, the obligation of Settling Defendants to complete the Work in strict accordance with the terms hereof.

53. The commencement of any Work Takeover pursuant to Paragraph 88 of this Consent Decree shall trigger EPA's right to receive the benefit of any Performance Guarantee provided pursuant to Paragraph 49(a), (b), (c), (d), or (f), and at such time EPA shall have immediate access to resources guaranteed under any such Performance Guarantee, whether in cash or in kind, as needed to continue and complete the Work assumed by EPA under the Work Takeover. If for any reason EPA is unable to promptly secure the resources guaranteed under any such Performance Guarantee, whether in cash or in kind, necessary to continue and complete the Work assumed by EPA under the Work Takeover, or in the event that the Performance Guarantee involves a demonstration of satisfaction of the financial test criteria pursuant to Paragraph 49(e), Settling Defendants shall immediately upon written demand from EPA deposit into an account specified by EPA, in immediately available funds and without setoff, counterclaim, or condition of any kind, a cash amount up to but not exceeding the estimated cost of the remaining Work to be performed as of such date, as determined by EPA.

54. Modification of Amount and/or Form of Performance Guarantee.

a. Reduction of Amount of Performance Guarantee. If Settling Defendants believe that the estimated cost to complete the remaining Work has diminished below the amount set forth in Paragraph 49 above, Settling Defendants may, on any anniversary date of the Effective Date of this Consent Decree, or at any other time agreed to by the Parties, petition EPA in writing to request a reduction in the amount of the Performance Guarantees provided pursuant to this Section so that the amount of the Performance Guarantees is equal to the estimated cost of the remaining Work to be performed. Settling Defendants shall submit a written proposal for such reduction to EPA that shall specify, at a minimum, the cost of the remaining Work to be performed and the basis upon which such cost was calculated. In seeking approval for a revised or alternative form of Performance Guarantee, Settling Defendants shall follow the procedures set forth in Paragraph 54(b)(2) of this Consent Decree. If EPA decides to accept such a proposal, EPA shall notify the petitioning Settling Defendants of such decision in writing. After receiving EPA's written acceptance, Settling Defendants may reduce the amount of the Performance Guarantees in accordance with and to the extent permitted by such written acceptance. In the event of a dispute, Settling Defendants may reduce the amount of the Performance Guarantees required hereunder only in accordance with a final administrative or judicial decision resolving such dispute. No change to the form or terms of any Performance Guarantee provided under this Section, other than a reduction in amount, is authorized except as provided in Paragraphs 52 or 54(b) of this Consent Decree.

b. Change of Form of Performance Guarantee.

(1) If, after the Effective Date of this Consent Decree, Settling Defendants desire to change the form or terms of any Performance Guarantee provided pursuant

to this Section, Settling Defendants may, on any anniversary date of the Effective Date of this Consent Decree, or at any other time agreed to by the Parties, petition EPA in writing to request a change in the form of the Performance Guarantees provided hereunder. The submission of such proposed revised or alternative form of Performance Guarantee shall be as provided in Paragraph 54(b)(2) of this Consent Decree. Any decision made by EPA on a petition submitted under this subparagraph (b)(1) shall be made in EPA's sole and unreviewable discretion, and such decision shall not be subject to challenge by Settling Defendants pursuant to the dispute resolution provisions of this Consent Decree or in any other forum.

(2) Settling Defendants shall submit a written proposal for a revised or alternative form of Performance Guarantee to EPA which shall specify, at a minimum, the estimated cost of the remaining Work to be performed, the basis upon which such cost was calculated, and the proposed revised form of Performance Guarantee, including all proposed instruments or other documents required in order to make the proposed Performance Guarantee legally binding. The proposed revised or alternative form of Performance Guarantee must satisfy all requirements set forth or incorporated by reference in this Section. Settling Defendants shall submit such proposed revised or alternative form of Performance Guarantee to the EPA Regional Financial Management Officer in accordance with Section XXVI (Notices and Submissions) of this Consent Decree, with a copy to Deborah Jourdan, Superfund Records Manager, US EPA, Region 4, 61 Forsyth Street, SW, Atlanta, GA 30303. EPA shall notify Settling Defendants in writing of its decision to accept or reject a revised or alternative Performance Guarantee submitted pursuant to this subparagraph. Within 10 days after receiving a written decision approving the proposed revised or alternative Performance Guarantees, Settling Defendants shall execute and/or otherwise finalize all instruments or other documents required in order to make

the selected Performance Guarantees legally binding in a form substantially identical to the documents submitted to EPA as part of the proposal, and such Performance Guarantees shall thereupon be fully effective. Settling Defendants shall submit all executed and/or otherwise finalized instruments or other documents required in order to make the selected Performance Guarantees legally binding to Deborah Jourdan, Superfund Records Manager, US EPA, Region 4, 61 Forsyth Street, SW, Atlanta, GA 30303 within 30 days of receiving a written decision approving the proposed revised or alternative Performance Guarantees in accordance with Section XXVI (“Notices and Submissions”) of this Consent Decree, with a copy to the United States and the State as specified in Section XXVI.

c. Release of Performance Guarantee. If Settling Defendants receive written notice from EPA in accordance with Paragraph 55 of this Consent Decree that the Work has been fully and finally completed in accordance with the terms of this Consent Decree, or if EPA otherwise so notifies Settling Defendants in writing, Settling Defendants may thereafter release, cancel, or discontinue the Performance Guarantees provided pursuant to this Section. Settling Defendants shall not release, cancel, or discontinue any Performance Guarantee provided pursuant to this Section except as provided in this subparagraph. In the event of a dispute, Settling Defendants may release, cancel, or discontinue the Performance Guarantees required hereunder only in accordance with a final administrative or judicial decision resolving such dispute.

XIV. CERTIFICATION OF COMPLETION

55. Completion of the Work.

a. Within 90 days after Settling Defendants conclude that all phases of the Work (including O&M), have been fully performed, Settling Defendants shall schedule and

conduct a pre-certification inspection to be attended by Settling Defendants, EPA and the State. If, after the pre-certification inspection, the Settling Defendants still believe that the Work has been fully performed, Settling Defendants shall submit a written report by a registered professional engineer stating that the Work has been completed in full satisfaction of the requirements of this Consent Decree. The report shall contain the following statement, signed by a responsible corporate official of a Settling Defendant or the Settling Defendants' Project Coordinator:

To the best of my knowledge, after thorough investigation, I certify that the information contained in or accompanying this submission is true, accurate and complete. I am aware that there are significant penalties for submitting false information, including the possibility of fine and imprisonment for knowing violations.

If, after review of the written report, EPA, after reasonable opportunity to review and comment by the State, determines that any portion of the Work has not been completed in accordance with this Consent Decree, EPA will notify Settling Defendants in writing of the activities that must be undertaken by Settling Defendants pursuant to this Consent Decree to complete the Work, provided, however, that EPA may only require Settling Defendants to perform such activities pursuant to this Paragraph to the extent that such activities are consistent with the "scope of the remedy selected in the ROD," as that term is defined in Paragraph 17(b). EPA will set forth in the notice a schedule for performance of such activities consistent with the Consent Decree and the SOW or require the Settling Defendants to submit a schedule to EPA for approval pursuant to Section XI (EPA Approval of Plans and Other Submissions). Settling Defendants shall perform all activities described in the notice in accordance with the specifications and schedules established therein, subject to their right to invoke the dispute resolution procedures set forth in Section XIX (Dispute Resolution).

b. If EPA concludes, based on the initial or any subsequent request for Certification of Completion by Settling Defendants and after a reasonable opportunity for review and comment by the State, that the Work has been performed in accordance with this Consent Decree, EPA will so notify the Settling Defendants in writing. This certification shall constitute the Certification of Completion of Work for purposes of this Consent Decree, including, but not limited to, Section XXI (Covenants Not to Sue by Plaintiff).

XV. EMERGENCY RESPONSE

56. In the event of any action or occurrence during the performance of the Work which causes or threatens a release of Waste Material from the Site that constitutes an emergency situation or may present an immediate threat to public health or welfare or the environment, Settling Defendants shall, subject to Paragraph 57, immediately take all appropriate action to prevent, abate, or minimize such release or threat of release, and shall immediately notify the EPA's Project Coordinator, or, if the Project Coordinator is unavailable, EPA's Alternate Project Coordinator. If neither of these persons is available, the Settling Defendants shall notify the EPA Emergency Response Section, Region 4. Settling Defendants shall take such actions in consultation with EPA's Project Coordinator or other available authorized EPA officer and in accordance with all applicable provisions of the Health and Safety Plans, the Contingency Plans, and any other applicable plans or documents developed pursuant to the SOW. In the event that Settling Defendants fail to take appropriate response action as required by this Section, and EPA or, as appropriate, the State takes such action instead, Settling Defendants shall reimburse EPA and the State all costs of the response action not inconsistent with the NCP pursuant to Section XVI (Payments for Response Costs).

57. Nothing in the preceding Paragraph or in this Consent Decree shall be deemed to

limit any authority of the United States, or the State, a) to take all appropriate action to protect human health and the environment or to prevent, abate, respond to, or minimize an actual or threatened release of Waste Material on, at, or from the Site, or b) to direct or order such action, or seek an order from the Court, to protect human health and the environment or to prevent, abate, respond to, or minimize an actual or threatened release of Waste Material on, at, or from the Site, subject to Section XXI (Covenants Not to Sue by Plaintiff).

XVI. PAYMENTS FOR RESPONSE COSTS

58. Payments for Future Response Costs.

a. Settling Defendants shall pay to EPA all Future Response Costs not inconsistent with the National Contingency Plan, excluding the first \$796,454.46 of Future Oversight Costs. On a periodic basis the United States will send Settling Defendants a bill requiring payment that includes an EPA Agency Financial Management System summary data (“SCORPIOS Report”), which includes direct and indirect costs incurred by EPA and its contractors, and the DOJ-prepared cost summary which reflects costs incurred by DOJ and its contractors, if any. Settling Defendants shall make all payments within 30 days of Settling Defendants’ receipt of each bill requiring payment, except as otherwise provided in Paragraph 59. Settling Defendants shall make all payments required by this Paragraph by a certified or cashier’s check or checks made payable to “EPA Hazardous Substance Superfund,” referencing the name and address of the party making the payment, EPA Site/Spill ID Number A4H9, and DOJ Case Number 90-11-3-09147. Settling Defendants shall send the check(s) to:

U.S. Environmental Protection Agency
Superfund Payments – Region 4
Cincinnati Finance Center
PO Box 979076
St. Louis, MO 63197-9000

Payment may also be made to EPA by EFT in accordance with current EFT procedures to be provided to Respondent by EPA Region 4, and shall be accompanied by a statement identifying the name and address of the party making payment, the Site name, the EPA Region (4) and Site/Spill ID Number A4H9 and the DOJ Case Number 90-11-3-09147. The EFT payment shall be wired as follows:

Federal Reserve Bank of New York
ABA = 021030004
Account = 68010727
SWIFT address = FRNYUS33
33 Liberty Street
New York, NY 10045
Field Tag 4200 of the Fedwire message should read “D 68010727 Environmental Protection Agency”

A copy of the check/EFT notice should be sent to:

Paula V. Painter
Superfund Enforcement & Information Management Branch
United States Environmental Protection Agency
Atlanta Federal Center
61 Forsyth Street, S.W.
Atlanta, GA 30303-8960

b. At the time of payment, Settling Defendants shall send notice that payment has been made to the United States and to EPA, in accordance with Section XXVI (Notices and Submissions).

c. The total amount to be paid by Settling Defendants pursuant to Paragraph 58(a) shall be deposited in the Landia Chemical Company Site Special Account within the EPA Hazardous Substance Superfund to be retained and used to conduct or finance response actions at

or in connection with the Site, or to be transferred by EPA to the EPA Hazardous Substance Superfund.

59. Settling Defendants may contest payment of any Future Response Costs under Paragraph 58 if they determine that the United States has made an accounting error or if they allege that a cost item that is included represents costs that are inconsistent with the NCP. Such objection shall be made in writing within 30 days of receipt of the bill and must be sent to the United States (if the United States' accounting is being disputed) pursuant to Section XXVI (Notices and Submissions). Any such objection shall specifically identify the contested Future Response Costs and the basis for objection. In the event of an objection, the Settling Defendants shall within the 30 day period pay all uncontested Future Response Costs to the United States in the manner described in Paragraph 58. Simultaneously, the Settling Defendants shall establish an interest-bearing escrow account in a federally-insured bank duly chartered in the State of Florida and remit to that escrow account funds equivalent to the amount of the contested Future Response Costs. The Settling Defendants shall send to the United States, as provided in Section XXVI (Notices and Submissions), a copy of the transmittal letter and check paying the uncontested Future Response Costs, and a copy of the correspondence that establishes and funds the escrow account, including, but not limited to, information containing the identity of the bank and bank account under which the escrow account is established as well as a bank statement showing the initial balance of the escrow account. Simultaneously with establishment of the escrow account, the Settling Defendants shall initiate the Dispute Resolution procedures in Section XIX (Dispute Resolution). If the United States prevails in the dispute, within 5 days of the resolution of the dispute, the Settling Defendants shall pay the sums due (with accrued interest) to the United States in the manner described in Paragraph 58. If the Settling Defendants

prevail concerning any aspect of the contested costs, the Settling Defendants shall pay that portion of the costs (plus associated accrued interest) for which they did not prevail to the United States in the manner described in Paragraph 58; Settling Defendants shall be disbursed any balance of the escrow account. The dispute resolution procedures set forth in this Paragraph in conjunction with the procedures set forth in Section XIX (Dispute Resolution) shall be the exclusive mechanisms for resolving disputes regarding the Settling Defendants' obligation to reimburse the United States for its Future Response Costs.

60. In the event that the payments required by Paragraph 58 are not made within 30 days of the Settling Defendants' receipt of the bill, Settling Defendants shall pay Interest on the unpaid balance. The Interest on Future Response Costs shall begin to accrue on the date of the bill. The Interest shall accrue through the date of the Settling Defendants' payment. Payments of Interest made under this Paragraph shall be in addition to such other remedies or sanctions available to Plaintiffs by virtue of Settling Defendants' failure to make timely payments under this Section including, but not limited to, payment of stipulated penalties pursuant to Paragraph 75. The Settling Defendants shall make all payments required by this Paragraph in the manner described in Paragraph 58.

XVII. INDEMNIFICATION AND INSURANCE

61. Settling Defendants' Indemnification of the United States.

a. The United States does not assume any liability by entering into this agreement or by virtue of any designation of Settling Defendants as EPA's authorized representatives under Section 104(e) of CERCLA. Settling Defendants shall indemnify, save and hold harmless the United States and its officials, agents, employees, contractors, subcontractors, or representatives for or from any and all claims or causes of action arising from,

or on account of, negligent or other wrongful acts or omissions of Settling Defendants, their officers, directors, employees, agents, contractors, subcontractors, and any persons acting on their behalf or under their control, in carrying out activities pursuant to this Consent Decree, including, but not limited to, any claims arising from any designation of Settling Defendants as EPA's authorized representatives under Section 104(e) of CERCLA. Further, the Settling Defendants agree to pay the United States all costs it incurs including, but not limited to, attorneys fees and other expenses of litigation and settlement arising from, or on account of, claims made against the United States based on negligent or other wrongful acts or omissions of Settling Defendants, their officers, directors, employees, agents, contractors, subcontractors, and any persons acting on their behalf or under their control, in carrying out activities pursuant to this Consent Decree. The United States shall not be held out as a party to any contract entered into by or on behalf of Settling Defendants in carrying out activities pursuant to this Consent Decree. Neither the Settling Defendants nor any such contractor shall be considered an agent of the United States or the State.

b. The United States shall give Settling Defendants notice of any claim for which the United States plans to seek indemnification pursuant to Paragraph 61, and shall consult with Settling Defendants prior to settling such claim.

62. Settling Defendants waive all claims against the United States for damages or reimbursement or for set-off of any payments made or to be made to the United States, arising from or on account of any contract, agreement, or arrangement between any one or more of Settling Defendants and any person for performance of Work on or relating to the Site, including, but not limited to, claims on account of construction delays. In addition, Settling Defendants shall indemnify and hold harmless the United States with respect to any and all

claims for damages or reimbursement arising from or on account of any contract, agreement, or arrangement between any one or more of Settling Defendants and any person for performance of Work on or relating to the Site, including, but not limited to, claims on account of construction delays.

63. No later than 15 days before commencing any on-site Work, Settling Defendants shall secure, or ensure that their contractors or subcontractors secure, and shall maintain until the first anniversary of EPA's Certification of Completion of the Work pursuant to Paragraph 55(b) of Section XIV (Certification of Completion), or ensure that their contractors or subcontractors maintain until such date, comprehensive general liability insurance with limits of one million dollars, combined single limit, and automobile liability insurance with limits of one million dollars, combined single limit, naming the United States an additional insured. In addition, for the duration of this Consent Decree, Settling Defendants shall satisfy, or shall ensure that their contractors or subcontractors satisfy, all applicable laws and regulations regarding the provision of worker's compensation insurance for all persons performing the Work on behalf of Settling Defendants in furtherance of this Consent Decree. Prior to commencement of the Work under this Consent Decree, Settling Defendants shall provide to EPA certificates of such insurance and a copy of each insurance policy. Settling Defendants shall resubmit such certificates and copies of policies each year on the anniversary of the Effective Date. If Settling Defendants demonstrate by evidence satisfactory to EPA that any contractor or subcontractor maintains insurance equivalent to that described above, or insurance covering the same risks but in a lesser amount, then, with respect to that contractor or subcontractor, Settling Defendants need provide only that portion of the insurance described above which is not maintained by the contractor or subcontractor.

XVIII. FORCE MAJEURE

64. “Force majeure,” for purposes of this Consent Decree, is defined as any event arising from causes beyond the control of the Settling Defendants, of any entity controlled by Settling Defendants, or of Settling Defendants’ contractors, that delays or prevents the performance of any obligation under this Consent Decree despite Settling Defendants’ best efforts to fulfill the obligation. The requirement that the Settling Defendants exercise “best efforts to fulfill the obligation” includes using best efforts to anticipate any potential force majeure event and best efforts to address the effects of any potential force majeure event (1) as it is occurring and (2) following the potential force majeure event, such that the delay is minimized to the greatest extent possible. “Force Majeure” does not include financial inability to complete the Work or a failure to attain the Performance Standards.

65. If any event occurs or has occurred that may delay the performance of any obligation under this Consent Decree, whether or not caused by a force majeure event, the Settling Defendants shall notify orally EPA’s Project Coordinator or, in his or her absence, EPA’s Alternate Project Coordinator or, in the event both of EPA’s designated representatives are unavailable, the Director of the Superfund Division, EPA Region 4, within 7 days of when Settling Defendants first knew that the event might cause a delay. Within 7 days thereafter, Settling Defendants shall provide in writing to EPA an explanation and description of the reasons for the delay; the anticipated duration of the delay; all actions taken or to be taken to prevent or minimize the delay; a schedule for implementation of any measures to be taken to prevent or mitigate the delay or the effect of the delay; the Settling Defendants’ rationale for attributing such delay to a force majeure event if they intend to assert such a claim; and a statement as to whether, in the opinion of the Settling Defendants, such event may cause or contribute to an

endangerment to public health, welfare or the environment. The Settling Defendants shall include with any notice all available documentation supporting their claim that the delay was attributable to a force majeure. Failure to comply with the above requirements shall preclude Settling Defendants from asserting any claim of force majeure for that event for the period of time of such failure to comply, and for any additional delay caused by such failure. Settling Defendants shall be deemed to know of any circumstance of which Settling Defendants, any entity controlled by Settling Defendants, or Settling Defendants' contractors knew or should have known.

66. If EPA agrees that the delay or anticipated delay is attributable to a force majeure event, the time for performance of the obligations under this Consent Decree that are affected by the force majeure event will be extended by EPA for such time as is necessary to complete those obligations. An extension of the time for performance of the obligations affected by the force majeure event shall not, of itself, extend the time for performance of any other obligation. If EPA does not agree that the delay or anticipated delay has been or will be caused by a force majeure event, EPA will notify the Settling Defendants in writing of its decision. If EPA agrees that the delay is attributable to a force majeure event, EPA will notify the Settling Defendants in writing of the length of the extension, if any, for performance of the obligations affected by the force majeure event.

67. If the Settling Defendants elect to invoke the dispute resolution procedures set forth in Section XIX (Dispute Resolution), they shall do so no later than 15 days after receipt of EPA's notice. In any such proceeding, Settling Defendants shall have the burden of demonstrating by a preponderance of the evidence that the delay or anticipated delay has been or will be caused by a force majeure event, that the duration of the delay or the extension sought

was or will be warranted under the circumstances, that best efforts were exercised to avoid and mitigate the effects of the delay, and that Settling Defendants complied with the requirements of Paragraphs 64 and 65, above. If Settling Defendants carry this burden, the delay at issue shall be deemed not to be a violation by Settling Defendants of the affected obligation of this Consent Decree identified to EPA and the Court.

XIX. DISPUTE RESOLUTION

68. Unless otherwise expressly provided for in this Consent Decree, the dispute resolution procedures of this Section shall be the exclusive mechanism to resolve disputes arising under or with respect to this Consent Decree. However, the procedures set forth in this Section shall not apply to actions by the United States to enforce obligations of the Settling Defendants that have not been disputed in accordance with this Section.

69. Any dispute which arises under or with respect to this Consent Decree shall in the first instance be the subject of informal negotiations between the parties to the dispute. The period for informal negotiations shall not exceed 20 days from the time the dispute arises, unless it is modified by written agreement of the parties to the dispute. The dispute shall be considered to have arisen when one party sends the other parties a written Notice of Dispute.

70. Statements of Position.

a. In the event that the parties cannot resolve a dispute by informal negotiations under the preceding Paragraph, then the position advanced by EPA shall be considered binding unless, within 10 days after the conclusion of the informal negotiation period, Settling Defendants invoke the formal dispute resolution procedures of this Section by serving on the United States a written Statement of Position on the matter in dispute, including, but not limited to, any factual data, analysis or opinion supporting that position and any supporting

documentation relied upon by the Settling Defendants. The Statement of Position shall specify the Settling Defendants' position as to whether formal dispute resolution should proceed under Paragraph 71 or Paragraph 72.

b. Within 10 days after receipt of Settling Defendants' Statement of Position, EPA will serve on Settling Defendants its Statement of Position, including, but not limited to, any factual data, analysis, or opinion supporting that position and all supporting documentation relied upon by EPA. EPA's Statement of Position shall include a statement as to whether formal dispute resolution should proceed under Paragraph 71 or 72. Within 10 days after receipt of EPA's Statement of Position, Settling Defendants may submit a Reply.

c. If there is disagreement between EPA and the Settling Defendants as to whether dispute resolution should proceed under Paragraph 71 or 72, the parties to the dispute shall follow the procedures set forth in the paragraph determined by EPA to be applicable. However, if the Settling Defendants ultimately appeal to the Court to resolve the dispute, the Court shall determine which paragraph is applicable in accordance with the standards of applicability set forth in Paragraphs 71 and 72.

71. Formal dispute resolution for disputes pertaining to the selection or adequacy of any response action and all other disputes that are accorded review on the administrative record under applicable principles of administrative law shall be conducted pursuant to the procedures set forth in this Paragraph. For purposes of this Paragraph, the adequacy of any response action includes, without limitation: (1) the adequacy or appropriateness of plans, procedures to implement plans, or any other items requiring approval by EPA under this Consent Decree; and (2) the adequacy of the performance of response actions taken pursuant to this Consent Decree. Nothing in this Consent Decree shall be construed to allow any dispute by Settling Defendants

regarding the validity of the ROD's provisions.

a. An administrative record of the dispute shall be maintained by EPA and shall contain all statements of position, including supporting documentation, submitted pursuant to this Section. Where appropriate, EPA may allow submission of supplemental statements of position by the parties to the dispute.

b. The Director of the Superfund Division, EPA Region 4, will issue a final administrative decision resolving the dispute based on the administrative record described in Paragraph 71(a). This decision shall be binding upon the Settling Defendants, subject only to the right to seek judicial review pursuant to Paragraph 71(c) and (d).

c. Any administrative decision made by EPA pursuant to Paragraph 71(b) shall be reviewable by this Court, provided that a motion for judicial review of the decision is filed by the Settling Defendants with the Court and served on all Parties within 10 days of receipt of EPA's decision. The motion shall include a description of the matter in dispute, the efforts made by the parties to resolve it, the relief requested, and the schedule, if any, within which the dispute must be resolved to ensure orderly implementation of this Consent Decree. The United States may file a response to Settling Defendants' motion.

d. In proceedings on any dispute governed by this Paragraph, Settling Defendants shall have the burden of demonstrating that the decision of the Superfund Division Director is arbitrary and capricious or otherwise not in accordance with law. Judicial review of EPA's decision shall be on the administrative record compiled pursuant to Paragraph 71(a).

72. Formal dispute resolution for disputes that neither pertain to the selection or adequacy of any response action nor are otherwise accorded review on the administrative record under applicable principles of administrative law shall be governed by this Paragraph.

a. Following receipt of Settling Defendants' Statement of Position submitted pursuant to Paragraph 70, the Director of the Superfund Division, EPA Region 4, will issue a final decision resolving the dispute. The Superfund Director's decision shall be binding on the Settling Defendants unless, within 10 days of receipt of the decision, the Settling Defendants file with the Court and serve on the parties a motion for judicial review of the decision setting forth the matter in dispute, the efforts made by the parties to resolve it, the relief requested, and the schedule, if any, within which the dispute must be resolved to ensure orderly implementation of the Consent Decree. The United States may file a response to Settling Defendants' motion.

b. Notwithstanding Paragraph L of Section I (Background) of this Consent Decree, judicial review of any dispute governed by this Paragraph shall be governed by applicable principles of law.

73. The invocation of formal dispute resolution procedures under this Section shall not extend, postpone or affect in any way any obligation of the Settling Defendants under this Consent Decree, not directly in dispute, unless EPA or the Court agrees otherwise. Stipulated penalties with respect to the disputed matter shall continue to accrue but payment shall be stayed pending resolution of the dispute as provided in Paragraph 82. Notwithstanding the stay of payment, stipulated penalties shall accrue from the first day of noncompliance with any applicable provision of this Consent Decree.

XX. STIPULATED PENALTIES

74. Settling Defendants shall be liable for stipulated penalties in the amounts set forth in Paragraphs 75 and 76 to the United States for failure to comply with the requirements of this Consent Decree specified below, unless excused under Section XVIII (Force Majeure). "Compliance" by Settling Defendants shall include completion of the activities under this

Consent Decree or any work plan or other plan approved under this Consent Decree identified below in accordance with all applicable requirements of law, this Consent Decree, the SOW, and any plans or other documents approved by EPA pursuant to this Consent Decree and within the specified time schedules established by and approved under this Consent Decree.

75. Stipulated Penalty Amounts - Work.

a. The following stipulated penalties shall accrue per violation per day for any failure to meet a Compliance Milestone identified in Paragraph 75(b):

<u>Penalty Per Violation Per Day</u>	<u>Period of Noncompliance</u>
\$1,250	1st through 14th day
\$2,500	15th through 30th day
\$3,500	31st day and beyond

b. Compliance Milestones. The Compliance Milestones include both the timely and adequate submittal, as defined in Section XI (EPA Approval of Plans and Other Submissions), of and substantial compliance with the following documents and substantive requirements, as specified in the SOW and this Consent Decree:

- (1) Draft Remedial Design Work Plan for Operable Unit One;
- (2) Final Remedial Design Work Plan for Operable Unit One;
- (3) Draft Remedial Action Work Plan for Operable Unit One;
- (4) Final Remedial Action Work Plan for Operable Unit One;
- (5) Performance Standards Verification Plan for Operable Unit One;
- (6) Remedial Action Report for Operable Unit One;
- (7) Draft Remedial Design Work Plan for Operable Unit Two;
- (8) Final Remedial Design Work Plan for Operable Unit Two;

- (9) Draft Remedial Action Work Plan for Operable Unit Two;
- (10) Final Remedial Action Work Plan for Operable Unit Two;
- (11) Remedial Action Report for Operable Unit Two;
- (12) Payments for Future Response Costs pursuant to Paragraph 58.

76. Stipulated Penalty Amounts - Reports.

a. The following stipulated penalties shall accrue per violation per day for failure to submit timely or adequate reports or other written documents pursuant to Section X, (Reporting Requirements):

<u>Penalty Per Violation Per Day</u>	<u>Period of Noncompliance</u>
\$500	1st through 14th day
\$1,500	15th through 30th day
\$3,000	31st day and beyond

77. In the event that EPA assumes performance of a portion or all of the Work pursuant to Paragraph 88 of Section XXI (Covenants Not to Sue by Plaintiff), Settling Defendants shall be liable for a stipulated penalty in the amount of \$850,000.

78. All penalties shall begin to accrue on the day after the complete performance is due or the day a violation occurs, and shall continue to accrue through the final day of the correction of the noncompliance or completion of the activity. However, stipulated penalties shall not accrue: (1) with respect to a deficient submission under Section XI (EPA Approval of Plans and Other Submissions), during the period, if any, beginning on the 31st day after EPA's receipt of such submission until the date that EPA notifies Settling Defendants of any deficiency; (2) with respect to a decision by the Director of the Superfund Division, EPA Region 4, under Paragraph 71(b) or 72(a) of Section XIX (Dispute Resolution), during the period, if any,

beginning on the 21st day after the date that Settling Defendants' reply to EPA's Statement of Position is received until the date that the Director issues a final decision regarding such dispute; or (3) with respect to judicial review by this Court of any dispute under Section XIX (Dispute Resolution), during the period, if any, beginning on the 31st day after the Court's receipt of the final submission regarding the dispute until the date that the Court issues a final decision regarding such dispute. Nothing herein shall prevent the simultaneous accrual of separate penalties for separate violations of this Consent Decree.

79. Following EPA's determination that Settling Defendants have failed to comply with a requirement of this Consent Decree, EPA may give Settling Defendants written notification of the same and describe the noncompliance. EPA may send the Settling Defendants a written demand for the payment of the penalties. However, penalties shall accrue as provided in the preceding Paragraph regardless of whether EPA has notified the Settling Defendants of a violation.

80. All penalties accruing under this Section shall be due and payable to the United States within 30 days of the Settling Defendants' receipt from EPA of a demand for payment of the penalties, unless Settling Defendants invoke the Dispute Resolution procedures under Section XIX (Dispute Resolution). All payments to the United States under this Section shall be paid by certified or cashier's check(s) made payable to "EPA Hazardous Substances Superfund," shall be mailed to "US Environmental Protection Agency, Fines and Penalties, Cincinnati Finance Center, PO Box 979077, St. Louis, MO 63197-9000," shall indicate that the payment is for stipulated penalties, and shall reference the EPA Region and Site/Spill ID # A4H9, the DOJ Case Number 90-11-3-09147, and the name and address of the party making payment. Copies of check(s) paid pursuant to this Section, and any accompanying transmittal letter(s), shall be sent

to the United States as provided in Section XXVI (Notices and Submissions), and to:

Paula V. Painter
Superfund Enforcement & Information Management Branch
United States Environmental Protection Agency
Atlanta Federal Center
61 Forsyth Street, S.W.
Atlanta, GA 30303-8960

81. The payment of penalties shall not alter in any way Settling Defendants' obligation to complete the performance of the Work required under this Consent Decree.

82. Penalties shall continue to accrue as provided in Paragraph 78 during any dispute resolution period, but need not be paid until the following:

a. If the dispute is resolved by agreement or by a decision of EPA that is not appealed to this Court, accrued penalties determined to be owing shall be paid to EPA within 15 days of the agreement or the receipt of EPA's decision or order;

b. If the dispute is appealed to this Court and the United States prevails in whole or in part, Settling Defendants shall pay all accrued penalties determined by the Court to be owed to EPA within 60 days of receipt of the Court's decision or order, except as provided in subparagraph (c) below;

c. If the District Court's decision is appealed by any Party, Settling Defendants shall pay all accrued penalties determined by the District Court to be owing to the United States into an interest-bearing escrow account within 60 days of receipt of the Court's decision or order. Penalties shall be paid into this account as they continue to accrue, at least every 60 days. Within 15 days of receipt of the final appellate court decision, the escrow agent shall pay the balance of the account to EPA or to Settling Defendants to the extent that they prevail.

83. If Settling Defendants fail to pay stipulated penalties when due, the United States may institute proceedings to collect the penalties, as well as interest. Settling Defendants shall pay Interest on the unpaid balance, which shall begin to accrue on the date of demand made pursuant to Paragraph 80.

84. Nothing in this Consent Decree shall be construed as prohibiting, altering, or in any way limiting the ability of the United States to seek any other remedies or sanctions available by virtue of Settling Defendants' violation of this Decree or of the statutes and regulations upon which it is based, including, but not limited to, penalties pursuant to Section 122(l) of CERCLA, provided, however, that the United States shall not seek civil penalties pursuant to Section 122(l) of CERCLA for any violation for which a stipulated penalty is provided herein, except in the case of a willful violation of the Consent Decree.

85. Notwithstanding any other provision of this Section, the United States may, in its unreviewable discretion, waive any portion of stipulated penalties that have accrued pursuant to this Consent Decree.

XXI. COVENANTS NOT TO SUE BY PLAINTIFF

86. In consideration of the actions that will be performed and the payments that will be made by the Settling Defendants under the terms of the Consent Decree, and except as specifically provided in Paragraph 87 of this Section, the United States covenants not to sue or to take administrative action against Settling Defendants pursuant to Sections 106 and 107(a) of CERCLA for performance of the Work and for recovery of Past Response Costs and Future Response Costs. These covenants not to sue shall take effect upon the Effective Date of this Consent Decree. These covenants not to sue are conditioned upon the satisfactory performance by Settling Defendants of their obligations under this Consent Decree. These covenants not to

sue extend only to the Settling Defendants and do not extend to any other person.

87. General reservations of rights. The United States reserves, and this Consent Decree is without prejudice to, all rights against Settling Defendants with respect to all matters not expressly included within Plaintiff's covenant not to sue. Notwithstanding any other provision of this Consent Decree, the United States reserves all rights against Settling Defendants with respect to:

- a. claims based on a failure by Settling Defendants to meet a requirement of this Consent Decree including the payment of all unreimbursed Future Response Costs as provided in Paragraph 58(a);
- b. liability arising from the past, present, or future disposal, release, or threat of release of Waste Material outside of the Site;
- c. liability arising from the disposal, release, or threat of release of a hazardous substance, pollutant, or contaminant at or in connection with the Site after signature of this Consent Decree by the Settling Defendants, which is based upon the Settling Defendants' ownership or operation of the Site, or upon the Settling Defendants' transportation, treatment, storage, or disposal, or the arrangement for the transportation, treatment, storage, or disposal of Waste Material at or in connection with the Site, other than as provided in the ROD, the Work, or otherwise ordered by EPA, after signature of this Consent Decree by the Settling Defendants;
- d. liability for damages for injury to, destruction of, or loss of natural resources, and for the costs of any natural resource damage assessments;
- e. criminal liability;
- f. liability for violations of federal or state law which occur during or after implementation of the Remedial Action;

g. liability, prior to Certification of Completion of the Work, for additional response actions that EPA determines are necessary to achieve Performance Standards, but that cannot be required pursuant to Paragraph 17 (Modification of the SOW or Related Work Plans);

h. liability for costs that the United States will incur related to the Site but are not within the definition of Future Response Costs; and

i. liability for costs incurred or to be incurred by the Agency for Toxic Substances and Disease Registry related to the Site.

88. Work Takeover.

a. In the event EPA determines that Settling Defendants have (i) ceased implementation of any portion of the Work, or (ii) are seriously or repeatedly deficient or late in their performance of the Work, or (iii) are implementing the Work in a manner which may cause an endangerment to human health or the environment, EPA may issue a written notice (“Work Takeover Notice”) to the Settling Defendants. Any Work Takeover Notice issued by EPA will specify the grounds upon which such notice was issued and will provide Settling Defendants a period of 10 days within which to remedy the circumstances giving rise to EPA’s issuance of such notice.

b. If, after expiration of the 10-day notice period specified in Paragraph 88(a), Settling Defendants have not remedied to EPA’s satisfaction the circumstances giving rise to EPA’s issuance of the relevant Work Takeover Notice, EPA may at any time thereafter assume the performance of all or any portions of the Work as EPA deems necessary (“Work Takeover”). EPA shall notify Settling Defendants in writing (which writing may be electronic) if EPA determines that implementation of a Work Takeover is warranted under this Paragraph 88(b).

c. Settling Defendants may invoke the procedures set forth in Section XIX (Dispute Resolution), Paragraph 71, to dispute EPA's implementation of a Work Takeover under Paragraph 88(b). However, notwithstanding Settling Defendants' invocation of such dispute resolution procedures, and during the pendency of any such dispute, EPA may in its sole discretion commence and continue a Work Takeover under Paragraph 88(b) until the earlier of (i) the date that Settling Defendants remedy, to EPA's satisfaction, the circumstances giving rise to EPA's issuance of the relevant Work Takeover Notice or (ii) the date that a final decision is rendered in accordance with Section XIX (Dispute Resolution), Paragraph 71, requiring EPA to terminate such Work Takeover.

d. After commencement and for the duration of any Work Takeover, EPA shall have immediate access to and benefit of any performance guarantee provided pursuant to Section XIII of this Consent Decree, in accordance with the provisions of Paragraph 53 of that Section. If and to the extent that EPA is unable to secure the resources guaranteed under any such performance guarantee and the Settling Defendants fail to remit a cash amount up to but not exceeding the estimated cost of the remaining Work to be performed, all in accordance with the provisions of Paragraph 53, any unreimbursed costs incurred by EPA in performing Work under the Work Takeover shall be considered Future Response Costs that Settling Defendants shall pay pursuant to Section XVI (Payments for Response Costs).

89. Notwithstanding any other provision of this Consent Decree, the United States and the State retain all authority and reserve all rights to take any and all response actions authorized by law.

XXII. COVENANTS BY SETTLING DEFENDANTS

90. Covenant Not to Sue. Subject to the reservations in Paragraph 91, Settling

Defendants hereby covenant not to sue and agree not to assert any claims or causes of action against the United States with respect to the Work and Past and Future Response Costs as defined herein or this Consent Decree, including, but not limited to:

- a. any direct or indirect claim for reimbursement from the Hazardous Substance Superfund (established pursuant to the Internal Revenue Code, 26 U.S.C. § 9507) through CERCLA Sections 106(b)(2), 107, 111, 112, 113 or any other provision of law;
- b. any claims against the United States, including any department, agency or instrumentality of the United States under CERCLA Sections 107 or 113 related to the Site, or
- c. any claims arising out of response actions at or in connection with the Site, including any claim under the United States Constitution, the Florida Constitution, the Tucker Act, 28 U.S.C. § 1491, the Equal Access to Justice Act, 28 U.S.C. § 2412, as amended, or at common law.

Except as provided in Paragraph 97 (Waiver of Claim-Splitting Defenses), these covenants not to sue shall not apply in the event that the United States brings a cause of action or issues an order pursuant to the reservations set forth in Paragraphs 87(b)-(d) or 87(g)-(i), but only to the extent that Settling Defendants' claims arise from the same response action, response costs, or damages that the United States is seeking pursuant to the applicable reservation.

91. The Settling Defendants reserve, and this Consent Decree is without prejudice to, claims against the United States, subject to the provisions of Chapter 171 of Title 28 of the United States Code, for money damages for injury or loss of property or personal injury or death caused by the negligent or wrongful act or omission of any employee of the United States while acting within the scope of his office or employment under circumstances where the United States, if a private person, would be liable to the claimant in accordance with the law of the place

where the act or omission occurred. However, any such claim shall not include a claim for any damages caused, in whole or in part, by the act or omission of any person, including any contractor, who is not a federal employee as that term is defined in 28 U.S.C. § 2671; nor shall any such claim include a claim based on EPA's selection of response actions, or the oversight or approval of the Settling Defendants' plans or activities. The foregoing applies only to claims which are brought pursuant to any statute other than CERCLA and for which the waiver of sovereign immunity is found in a statute other than CERCLA.

92. Nothing in this Consent Decree shall be deemed to constitute preauthorization of a claim within the meaning of Section 111 of CERCLA, 42 U.S.C. § 9611, or 40 C.F.R. § 300.700(d).

XXIII. EFFECT OF SETTLEMENT; CONTRIBUTION PROTECTION

93. Nothing in this Consent Decree shall be construed to create any rights in, or grant any cause of action to, any person not a Party to this Consent Decree. The preceding sentence shall not be construed to waive or nullify any rights that any person not a signatory to this decree may have under applicable law. Each of the Parties expressly reserves any and all rights (including, but not limited to, any right to contribution), defenses, claims, demands, and causes of action which each Party may have with respect to any matter, transaction, or occurrence relating in any way to the Site against any person not a Party hereto.

94. The Parties agree, and by entering this Consent Decree this Court finds, that the Settling Defendants are entitled, as of the Effective Date, to protection from contribution actions or claims as provided by CERCLA Section 113(f)(2), 42 U.S.C. § 9613(f)(2) for matters addressed in this Consent Decree. The "matters addressed" in this settlement are Past and Future Response Costs and the Work as defined herein. The "matters addressed" in this settlement do

not include those response costs or response actions as to which the United States has reserved its rights under this Consent Decree (except for claims for failure to comply with this Decree), in the event that the United States asserts rights against Settling Defendants coming within the scope of such reservations.

95. The Settling Defendants agree that with respect to any suit or claim for contribution brought by them for matters related to this Consent Decree they will notify the other Parties in writing no later than 60 days prior to the initiation of such suit or claim.

96. The Settling Defendants also agree that with respect to any suit or claim for contribution brought against them for matters related to this Consent Decree they will notify in writing the United States within 10 days of service of the complaint on them. In addition, Settling Defendants shall notify the United States within 10 days of service or receipt of any Motion for Summary Judgment and within 10 days of receipt of any order from a court setting a case for trial.

97. In any subsequent administrative or judicial proceeding initiated by the United States for injunctive relief, recovery of response costs, or other appropriate relief relating to the Site, Settling Defendants shall not assert, and may not maintain, any defense or claim based upon the principles of waiver, res judicata, collateral estoppel, issue preclusion, claim-splitting, or other defenses based upon any contention that the claims raised by the United States in the subsequent proceeding were or should have been brought in the instant case; provided, however, that nothing in this Paragraph affects the enforceability of the covenants not to sue set forth in Section XXI (Covenants Not to Sue by Plaintiff).

XXIV. ACCESS TO INFORMATION

98. Settling Defendants shall provide to EPA and the State, upon request, copies of all

documents and information within their possession or control or that of their contractors or agents relating to activities at the Site or to the implementation of this Consent Decree, including, but not limited to, sampling, analysis, chain of custody records, manifests, trucking logs, receipts, reports, sample traffic routing, correspondence, or other documents or information related to the Work. Settling Defendants shall also make available to EPA and the State, for purposes of investigation, information gathering, or testimony, their employees, agents, or representatives with knowledge of relevant facts concerning the performance of the Work.

99. Business Confidential and Privileged Documents.

a. Settling Defendants may assert business confidentiality claims covering part or all of the documents or information submitted to Plaintiff under this Consent Decree to the extent permitted by and in accordance with Section 104(e)(7) of CERCLA, 42 U.S.C. § 9604(e)(7), and 40 C.F.R. § 2.203(b). Documents or information determined to be confidential by EPA will be afforded the protection specified in 40 C.F.R. Part 2, Subpart B. If no claim of confidentiality accompanies documents or information when they are submitted to EPA and the State, or if EPA has notified Settling Defendants that the documents or information are not confidential under the standards of Section 104(e)(7) of CERCLA or 40 C.F.R. Part 2, Subpart B, the public may be given access to such documents or information without further notice to Settling Defendants.

b. Settling Defendants may assert that certain documents, records and other information are privileged under the attorney-client privilege or any other privilege recognized by federal law. If Settling Defendants assert such a privilege in lieu of providing documents, they shall provide the Plaintiff with the following: (1) the title of the document, record, or information; (2) the date of the document, record, or information; (3) the name and title of the

author of the document, record, or information; (4) the name and title of each addressee and recipient; (5) a description of the contents of the document, record, or information; and (6) the privilege asserted by Settling Defendants. However, no documents, reports or other information created or generated pursuant to the requirements of the Consent Decree shall be withheld on the grounds that they are privileged.

100. No claim of confidentiality shall be made with respect to any data, including, but not limited to, all sampling, analytical, monitoring, hydrogeologic, scientific, chemical, or engineering data, or any other documents or information evidencing conditions at or around the Site.

XXV. RETENTION OF RECORDS

101. Until 5 years after the Settling Defendants' receipt of EPA's notification pursuant to Paragraph 55(b) of Section XIV (Certification of Completion), each Settling Defendant shall preserve and retain all non-identical copies of records and documents (including records or documents in electronic form) now in its possession or control or which come into its possession or control that relate in any manner to its liability under CERCLA with respect to the Site, provided, however, that Settling Defendants who are potentially liable as owners or operators of the Site must retain, in addition, all documents and records that relate to the liability of any other person under CERCLA with respect to the Site. Each Settling Defendant must also retain, and instruct its contractors and agents to preserve, for the same period of time specified above all non-identical copies of the last draft or final version of any documents or records (including documents or records in electronic form) now in its possession or control or which come into its possession or control that relate in any manner to the performance of the Work, provided, however, that each Settling Defendant (and its contractors and agents) must retain, in addition,

copies of all data generated during the performance of the Work and not contained in the aforementioned documents required to be retained. Each of the above record retention requirements shall apply regardless of any corporate retention policy to the contrary.

102. At the conclusion of this document retention period, Settling Defendants shall notify the United States at least 90 days prior to the destruction of any such records or documents, and, upon request by the United States, Settling Defendants shall deliver any such records or documents to EPA. The Settling Defendants may assert that certain documents, records and other information are privileged under the attorney-client privilege or any other privilege recognized by federal law. If the Settling Defendants assert such a privilege, they shall provide the Plaintiffs with the following: (1) the title of the document, record, or information; (2) the date of the document, record, or information; (3) the name and title of the author of the document, record, or information; (4) the name and title of each addressee and recipient; (5) a description of the subject of the document, record, or information; and (6) the privilege asserted by Settling Defendants. However, no documents, reports or other information created or generated pursuant to the requirements of the Consent Decree shall be withheld on the grounds that they are privileged.

103. Each Settling Defendant hereby certifies individually that, to the best of its knowledge and belief, after thorough inquiry, it has not altered, mutilated, discarded, destroyed or otherwise disposed of any records, documents or other information (other than identical copies) relating to its potential liability regarding the Site since notification of potential liability by the United States or the State or the filing of suit against it regarding the Site and that it has fully complied with any and all EPA requests for information pursuant to Section 104(e) and 122(e) of CERCLA, 42 U.S.C. 9604(e) and 9622(e), and Section 3007 of RCRA, 42 U.S.C.

§ 6927.

XXVI. NOTICES AND SUBMISSIONS

104. Whenever, under the terms of this Consent Decree, written notice is required to be given or a report or other document is required to be sent by one Party to another, it shall be directed to the individuals at the addresses specified below, unless those individuals or their successors give notice of a change to the other Parties in writing. All notices and submissions shall be considered effective upon receipt, unless otherwise provided. Written notice as specified herein shall constitute complete satisfaction of any written notice requirement of the Consent Decree with respect to the United States, EPA, the State, and the Settling Defendants, respectively.

As to the United States:

Chief, Environmental Enforcement Section
Environment and Natural Resources Division
U.S. Department of Justice
P.O. Box 7611
Washington, D.C. 20044-7611
Re: DJ # 90-11-3-09147

and

Franklin E. Hill
Director, Superfund Division
United States Environmental Protection Agency
Region 4
61 Forsyth Street, SW
Atlanta, GA 30303

As to EPA:

William Denman
EPA Project Coordinator
United States Environmental Protection Agency
Region 4
61 Forsyth Street, SW
Atlanta, GA 30303

and

Paula V. Painter
Superfund Enforcement & Information
Management Branch
US Environmental Protection Agency
Region 4
61 Forsyth Street, SW
Atlanta, GA 30303

As to the State of Florida:

Christopher Pellegrino, Project Manager
Florida Department of Environmental Protection
Hazardous Waste Cleanup Section
2600 Blair Stone Road
Tallahassee, FL 32399

As to the Settling Defendants:

Agrico
c/o Phil Roberts
Williams Companies
One Williams Center, Ste. 4800
Tulsa, OK 74172

and

PCS Joint Venture, Ltd.
c/o Michael Brom
Director, Environment
PCS Administration (USA), Inc.
1101 Skokie Blvd., Suite 400
Northbrook, IL 60062

and

BASF Sparks LLC
c/o Linda Brenneman, Esq.
BASF Corporation
100 Campus Drive
Florham Park, NJ 07932

XXVII. EFFECTIVE DATE

105. The effective date of this Consent Decree shall be the date upon which this Consent Decree is entered by the Court, except as otherwise provided herein.

XXVIII. RETENTION OF JURISDICTION

106. This Court retains jurisdiction over both the subject matter of this Consent Decree and the Settling Defendants for the duration of the performance of the terms and provisions of this Consent Decree for the purpose of enabling any of the Parties to apply to the Court at any time for such further order, direction, and relief as may be necessary or appropriate for the construction or modification of this Consent Decree, or to effectuate or enforce compliance with its terms, or to resolve disputes in accordance with Section XIX (Dispute Resolution) hereof.

XXIX. APPENDICES

107. The following appendices are attached to and incorporated into this Consent Decree:

“Appendix A” is the ROD.

“Appendix B” is the SOW.

“Appendix C” is the map of the Site.

“Appendix D” is the draft Declaration of Restrictive Covenants.

“Appendix E” is the MOA.

“Appendix F” is the Performance Guarantees.

XXX. COMMUNITY RELATIONS

108. Settling Defendants shall propose to EPA their participation in the community relations plan to be developed by EPA. EPA will determine the appropriate role for the Settling Defendants under the Plan. Settling Defendants shall also cooperate with EPA in providing information regarding the Work to the public. As requested by EPA, Settling Defendants shall participate in the preparation of such information for dissemination to the public and in public meetings which may be held or sponsored by EPA to explain activities at or relating to the Site.

XXXI. MODIFICATION

109. Schedules specified in this Consent Decree for completion of the Work may be modified by agreement of EPA and the Settling Defendants. All such modifications shall be made in writing.

110. Except as provided in Paragraph 17 (Modification of the SOW or Related Work Plans), no material modifications shall be made to the SOW without written notification to and written approval of the United States, Settling Defendants, and the Court, if such modifications fundamentally alter the basic features of the selected remedy within the meaning of 40 C.F.R. § 300.435(c)(2)(B)(ii). Prior to providing its approval to any modification, the United States will provide the State with a reasonable opportunity to review and comment on the proposed modification. Modifications to the SOW that do not materially alter that document, or material modifications to the SOW that do not fundamentally alter the basic features of the selected remedy within the meaning of 40 C.F.R. § 300.435(c)(2)(B)(ii), may be made by written agreement between EPA, after providing the State with a reasonable opportunity to review and comment on the proposed modification, and the Settling Defendants.

111. Nothing in this Decree shall be deemed to alter the Court's power to enforce, supervise or approve modifications to this Consent Decree.

XXXII. LODGING AND OPPORTUNITY FOR PUBLIC COMMENT

112. This Consent Decree shall be lodged with the Court for a period of not less than 30 days for public notice and comment in accordance with Section 122(d)(2) of CERCLA, 42 U.S.C. § 9622(d)(2), and 28 C.F.R. § 50.7. The United States reserves the right to withdraw or withhold its consent if the comments regarding the Consent Decree disclose facts or considerations which indicate that the Consent Decree is inappropriate, improper, or inadequate.

Settling Defendants consent to the entry of this Consent Decree without further notice.

113. If for any reason the Court should decline to approve this Consent Decree in the form presented, this agreement is voidable at the sole discretion of any Party and the terms of the agreement may not be used as evidence in any litigation between the Parties.

XXXIII. SIGNATORIES/SERVICE

114. Each undersigned representative of a Settling Defendant to this Consent Decree and the Deputy Section Chief for the Environmental Enforcement Section of the Department of Justice certify that they are fully authorized to enter into the terms and conditions of this Consent Decree and to execute and legally bind the Parties they represent to this document.

115. Each Settling Defendant hereby agrees not to oppose entry of this Consent Decree by this Court or to challenge any provision of this Consent Decree unless the United States has notified the Settling Defendants in writing that it no longer supports entry of the Consent Decree.

116. Each Settling Defendant shall identify, on the attached signature page, the name, address and telephone number of an agent who is authorized to accept service of process by mail on behalf of that Party with respect to all matters arising under or relating to this Consent Decree. Settling Defendants hereby agree to accept service in that manner and to waive the formal service requirements set forth in Rule 4 of the Federal Rules of Civil Procedure and any applicable local rules of this Court, including, but not limited to, service of a summons. The parties agree that Settling Defendants need not file an answer to the complaint in this action unless or until the court expressly declines to enter this Consent Decree.

XXXIV. FINAL JUDGMENT

117. This Consent Decree and its appendices constitute the final, complete, and exclusive agreement and understanding among the parties with respect to the settlement

embodied in the Consent Decree. The parties acknowledge that there are no representations, agreements or understandings relating to the settlement other than those expressly contained in this Consent Decree.

118. Upon approval and entry of this Consent Decree by the Court, this Consent Decree shall constitute a final judgment between and among the United States and the Settling Defendants. The Court finds that there is no just reason for delay and therefore enters this judgment as a final judgment under Fed. R. Civ. P. 54 and 58.

SO ORDERED THIS 27th DAY OF August, 2009.

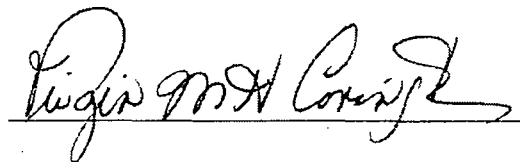

United States District Judge

THE UNDERSIGNED PARTY enters into this Consent Decree in the matter of United States v. Landia Chemical Company, Inc. et al. relating to the Landia Chemical Company Site:

FOR THE UNITED STATES OF AMERICA

7/10/09
Date

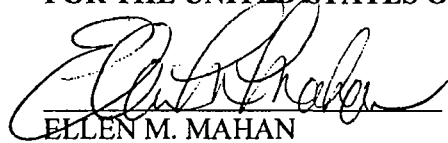

ELLEN M. MAHAN
Deputy Section Chief
Environmental Enforcement Section
Environment and Natural Resources Division
U.S. Department of Justice
Washington, D.C. 20530

7/10/09
Date



MARK SABATH
Trial Attorney
Environmental Enforcement Section
Environment and Natural Resources Division
U.S. Department of Justice
P.O. Box 7611
Washington, D.C. 20044-7611

THE UNDERSIGNED PARTY enters into this Consent Decree in the matter of United States v. Landia Chemical Company, Inc. et al. relating to the Landia Chemical Company Site:

A. BRIAN ALBRITTON
United States Attorney

7/10/09
Date

E. Kenneth Stegeby /MES
E. KENNETH STEGEBY
Assistant United States Attorney
Middle District of Florida
400 N. Tampa Street, Suite 3200
Tampa, FL 33602

THE UNDERSIGNED PARTY enters into this Consent Decree in the matter of United States v. Landia Chemical Company, Inc. et al. relating to the Landia Chemical Company Site:

6/12/09
Date

FRANKLIN E. HILL.
Director, Superfund Division
U.S. Environmental Protection Agency
Region 4
Atlanta Federal Center
61 Forsyth Street, SW
Atlanta, GA 30303

May 27, 2009
Date

DAVID L. HARBIN
Assistant Regional Counsel
U.S. Environmental Protection Agency
Region 4
61 Forsyth Street, SW
Atlanta. GA 30303

THE UNDERSIGNED PARTY enters into this Consent Decree in the matter of United States v. Landia Chemical Company, Inc. et al. relating to the Landia Chemical Company Site:

FOR LANDIA CHEMICAL COMPANY, INC.

MAY 18, 2009
Date

Billy G. Mitchell
[Name] BILLY G. MITCHELL
[Title] PRES.
[Address] 1586 GULF BLVD APT 2701
CLEARWATER FL 33767

Agent authorized to accept service on behalf of above-signed party:

[Name] JOHN B BRANNAN
[Title] CPA
[Address] 6115 MAGNOLIA AVE
[Phone #] TAMPA FL 33606
813 251-2411

THE UNDERSIGNED PARTY enters into this Consent Decree in the matter of United States v. Landia Chemical Company, Inc. et al. relating to the Landia Chemical Company Site:

FOR AGRICO CHEMICAL COMPANY

5-6-09

Date

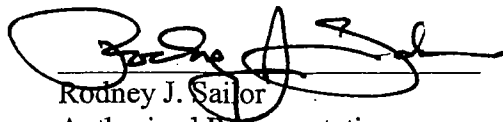

Rodney J. Sailor
Authorized Representative
One Williams Center, Suite 50-4
Tulsa, OK 74172

Agent authorized to accept service on behalf of above-signed party:

Lloyd Landreth
Counsel
801 "B" Street
Jenks, OK 74037
918-296-0460

THE UNDERSIGNED PARTY enters into this Consent Decree in the matter of United States v. Landia Chemical Company, Inc. et al. relating to the Landia Chemical Company Site:

FOR BASF SPARKS LLC

May 12, 2009

Date



[Name] Steven J. Goldberg
[Title] Assistant Secretary
[Address] c/o BASF Corporation
100 Campus Drive
Florham Park, NJ 07932

Agent authorized to accept service on behalf of above-signed party:

[Name] CT Corporation System
[Title]
[Address] 1201 Peachtree Street, NE
Atlanta, GA 30361
[Phone #]

THE UNDERSIGNED PARTY enters into this Consent Decree in the matter of United States v. Landia Chemical Company, Inc. et al. relating to the Landia Chemical Company Site:

FOR PCS JOINT VENTURE, LTD.

**By: Its General Partner
Potash Corporation of Saskatchewan
(Florida), Inc.**

5/13/09
Date

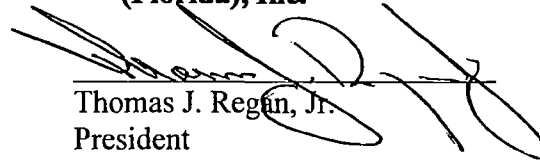
Thomas J. Regan, Jr.
President
1101 Skokie Boulevard
Suite 400
Northbrook, IL 60062

Agent authorized to accept service on behalf of above-signed party:

Karin S. Torain
Senior Counsel
1101 Skokie Boulevard
Suite 400
Northbrook, IL 60062
847-849-4291

THE UNDERSIGNED PARTY enters into this Consent Decree in the matter of United States v. Landia Chemical Company, Inc. et al. relating to the Landia Chemical Company Site:

FOR SYLVITE TERMINAL & DISTRIBUTION LLC

May 14, 2009

Date

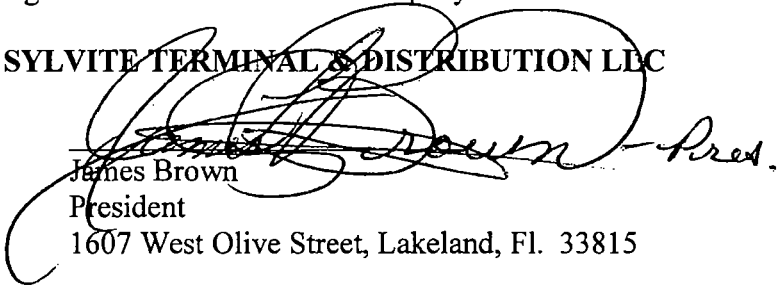
James Brown

President

1607 West Olive Street, Lakeland, Fl. 33815

Agent authorized to accept service on behalf of above-signed party:

James Brown

President

1607 West Olive Street, Lakeland, Fl. 33815

717-269-1193

THE UNDERSIGNED PARTY enters into this Consent Decree in the matter of United States v. Landia Chemical Company, Inc. et al. relating to the Landia Chemical Company Site:

FOR BILLY G. MITCHELL

MAY 18, 2009
Date

Billy Mitchell
[Name]
[Title]
[Address] 1586 GULF BLVD APT 2701
CLEARWATER FL 33767

THE UNDERSIGNED PARTY enters into this Consent Decree in the matter of United States v. Landia Chemical Company, Inc. et al. relating to the Landia Chemical Company Site:

FOR WALTER G. GRAHN

5/20/09
Date

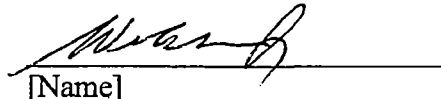

[Name]

[Title]

[Address]

LONGBOAT KEY, FL. 34228

1211 GULF OF MEXICO DR. APT. 611

WALTER G. GRAHN JR.

WALTER G. GRAHN JR.

1211 GULF OF MEXICO DR. APT. 611

LONGBOAT KEY, FL. 34228

APPENDIX A

RECORD OF DECISION

Summary of the Final Remedial
Alternative Selection
for the Soil

and

An Interim Remedial Alternative
Selection for the Groundwater

at the

Landia Chemical Company Site
Lakeland, Polk County, Florida

Prepared by the
United States Environmental Protection Agency

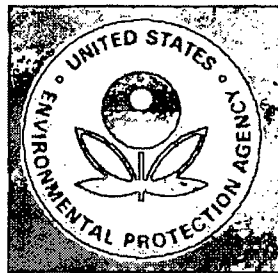

RECORD OF DECISION

Declaration

Site Name and Location

Landia Chemical Company (FLD042110841)

Lakeland, Polk County, Florida

Operable Unit One (Soil) - Final Action

Operable Unit Two (Groundwater) – Interim Action

Statement of Basis and Purpose

This decision document presents the selected remedial action for the Landia Chemical Company Site (the "Site") in Lakeland, Florida, which was chosen in accordance with the Comprehensive Environmental Response, Compensation and Liability Act (CERCLA) of 1980, as amended by the Superfund Amendments and Reauthorization Act (SARA) of 1986, and the National Oil and Hazardous Substances Pollution Contingency Plan (NCP). This decision is based on the Administrative Record file for this Site.

The State of Florida, as represented by the Florida Department of Environmental Protection (FDEP), has been the support agency during the remedial investigation/feasibility study process for the Site. In accordance with 40 Code of Federal Regulation (CFR) Sec 300.430, as the support agency, FDEP has provided input during the process.

Assessment of Site

The response action selected in this Record of Decision is necessary to protect human health and the environment from actual or threatened releases of hazardous substances, pollutants or contaminants into the environment.

Description of Selected Remedy

This remedy includes the final action to address potential human exposure to contaminants in the soil (Operable Unit One - OU1) associated with the Site and an interim action to treat the most contaminated groundwater. After implementation and evaluation of the effectiveness of the interim action on reducing groundwater contaminant concentrations, a final action to address potential human exposure to contaminants in the groundwater (Operable Unit Two - OU2) will be selected to reach the ultimate goal of restoring the aquifer to drinking water standards. Most principal threat wastes that were originally present at the Site were removed during the previous removal actions. A small amount of principal threat wastes remain in the subsurface soil just above the water table. If not addressed, these remaining principal threat wastes would likely migrate into the groundwater at levels well above drinking water standards and significantly increase the amount of time needed to achieve cleanup standards. The remaining principal threat wastes will be addressed through excavation.

The major components of the remedy include:

- Excavation and off-site disposal of contaminated soil, a limited amount of which constitutes principal threats for unacceptable exposure to, and/or migration of, chemicals of concern (COCs);
- An interim action to treat the areas of groundwater which have been most impacted by site-related contaminants. This interim action shall consist of in-situ chemical oxidation treatment in pesticide source areas to address the highest groundwater contaminant concentrations and in-situ bioremediation in other selected areas to enhance the natural attenuation process. This interim action shall be implemented *within a boundary established in the ROD which consists of areas north of Olive Street* and shall be further refined during the remedial design phase. A performance monitoring plan shall be developed to evaluate the effectiveness of the soil remedy and the groundwater interim action on groundwater contaminant concentrations; and
- Institutional Controls to prevent exposure to contaminants including groundwater use restrictions, restrictive covenants added to deeds for the Florida Favorite Fertilizer (FFF) and Landia properties, and engineering controls to prevent exposure to soil contaminants.

Statutory Determinations

The Selected Remedy is protective of human health and the environment, complies with Federal and State requirements that are applicable or relevant and appropriate to the remedial action, is cost effective, and utilizes permanent solutions to the maximum extent practicable.

The remedy for soil (OU1) does not satisfy the statutory preference for treatment as a principal element of the remedy. Treatment of COCs is not part of the selected remedy because the soil to be remediated has relatively low contaminant levels. Most principal threat wastes were removed during the previous removal actions and only isolated areas of principal threat wastes remain. Due to the relatively small volumes of principal threat wastes remaining, the remedial technologies considered were consistent with the removal actions and included excavation and off-site disposal. The interim remedy for groundwater (OU2) satisfies the preference for treatment. The remedy will include a treatment process using chemical oxidation in areas with elevated levels of pesticide groundwater contamination and in-situ bioremediation in other areas of the treatment zone, reducing the toxicity, mobility and volume of COCs. Any excavated soil and sediment with characteristics requiring it to be classified as a RCRA hazardous waste will be treated pursuant to RCRA requirements (40 CFR 268) prior to disposal in an offsite Subtitle D landfill.

Because this remedy will result in hazardous substances, pollutants, or contaminants remaining on-site above levels that allow for unlimited use and unrestricted exposure, a statutory review will be conducted within five years after initiation of remedial action to ensure that the remedy is, and will continue to be, protective of human health and the environment.

ROD Data Certification Checklist

The following information is included in the Decision Summary, Part 2, of this Record of Decision. Additional information can be found in the Administrative Record file for this Site.

- Chemicals of Concern (COCs) and their respective concentrations.
- Baseline risk represented by the COCs.
- Cleanup levels established for COCs and the basis for these levels.
- How source materials constituting principal threats are addressed.
- Current and reasonably anticipated future land use assumptions and current and potential future beneficial uses of groundwater used in the baseline risk assessment and the ROD.
- Potential land and groundwater use that will be available at the Site as a result of the Selected Remedy.
- Estimated capital, annual operation and maintenance (O&M), and total present worth costs; discount rate; and the number of years over which the remedy cost estimates are projected.
- Key factors that led to selecting the remedy.

Authorizing Signature

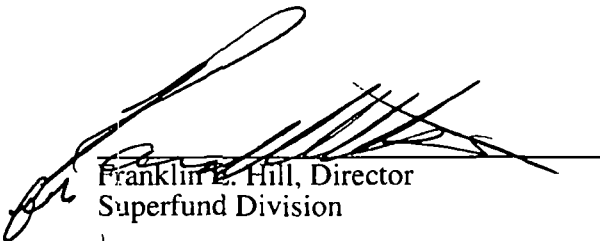

Franklin E. Hill, Director
Superfund Division

9/27/07
Date

Table of Contents

1.0 Site Location and Description	1
2.0 Site History and Enforcement Activities.....	4
2.1 History of Site Operations	4
2.2 Prior Federal and State Site Investigations and Removal Actions	4
2.3 History of CERCLA Enforcement Activities	5
3.0 Community Participation	6
4.0 Scope and Role of Response Action	7
5.0 Site Characteristics	8
5.1 Site Features, Topography, Surface Water and Drainage.....	8
5.2 Site Hydrogeology	8
5.3 Nature and Extent of Contamination	8
5.3.1 Source Materials and Soil Impacts	11
5.3.2 Groundwater Impacts.....	14
5.3.3 Sediment Impacts.....	17
5.3.4 Surface Water Impacts.....	17
6.0 Current and Potential Future Land and Resource Use.....	18
6.1 Current and Anticipated Future Land Use	18
6.2 Current and Anticipated Future Resource Use	18
7.0 Summary of Site Risks.....	19
7.1 Summary of Human Health Risk Assessment.....	20
7.1.1 Chemicals of Concern.....	20
7.1.2 Exposure Assessment	21
7.1.3 Toxicity Assessment.....	24
7.1.4 Risk Characterization.....	24
7.1.5 Refinement of COCs.....	25
7.1.6 Uncertainty.....	27
7.2 Summary of Ecological Risk Assessment	29
7.2.1 Screening Level Ecological Risk Assessment (SLERA).....	29
7.2.2 Uncertainty.....	29

8.0 Remedial Action Objectives.....	32
9.0 Description of Alternatives	33
9.1 Alternative S1: No Action	33
9.2 Alternative S2: Excavation with off-site disposal of soils.....	33
9.3 Alternative S3: Excavation with partial off-site disposal of soils and partial on-site consolidation and capping.....	35
9.4 Groundwater Interim Action: In-Situ Treatment of Groundwater Using Chemical Oxidation of Hotspots and Bioremediation of Elevated Residuals above NADCs.....	36
10.0 Summary of Comparative Analysis of Alternatives	39
10.1 Overall Protection of Human Health and the Environment.....	41
10.2 Compliance with ARARs	42
10.3 Long Term Effectiveness and Permanence	48
10.4 Reduction of Toxicity, Mobility, or Volume through Treatment.....	48
10.5 Short Term Effectiveness.....	49
10.6 Implementability.....	50
10.7 Costs.....	50
10.8 State Acceptance.....	51
10.9 Community Acceptance.....	51
11.0 Principal Threat Wastes	52
12.0 Summary of Selected Remedy.....	53
12.1 Summary of Rationale for the Selected Remedy.....	53
12.2 Description of the Selected Remedy.....	54
12.2.1 Selected Soil Remedy	54
12.2.2 Interim Action for Groundwater	54
12.2.3 Institutional controls	56
12.2.4 Final Selected Cleanup Goals	57
12.3 Summary of the Estimated Remedy Costs	59
12.4 Expected Outcomes of the Selected Remedy	65
13.0 Statutory Determinations	66
13.1 Protection of Human Health and the Environment.....	66
13.2 Compliance with ARARs	66
13.3 Cost Effectiveness.....	66

13.4 Use of Permanent Solutions and Alternative Treatment Technologies to the Maximum Extent Practicable	70
13.5 Preference for Treatment as a Principal Element	70
13.6 Five-Year Review Requirements	71
14.0 Documentation of Significant Changes	71

List of Tables

Table 1	Risk Assessment Cleanup Levels and Exposure Point Concentrations for Detected Chemicals in Soil (Residential Area)
Table 2	Risk Assessment Cleanup Levels and Exposure Point Concentrations for Detected Chemicals in Soil (Industrial Area)
Table 3	Identification of Action-Specific ARARs
Table 4	Identification of Constituent-Specific ARARs
Table 5	Cleanup Goals for Soil and Groundwater
Table 6	Evaluation of Probable Costs for Excavation and Off-Site Disposal of Soils (Soil Alternative S2), Landia Site, Lakeland, Florida
Table 7	20-Year Evaluation of Probable Costs for Treatment Train Using Chemical Oxidation, In-situ Bioremediation Excavation and Monitoring, Landia Site, Lakeland, Florida
Table 8	ARARs for Selected Remedy

List of Figures

Figure 1	Site Map
Figure 2	Site Vicinity
Figure 3	Conceptual Site Model
Figure 4	Extent of Soil Contamination
Figure 5	Extent of Groundwater Contamination
Figure 6	Area of Soil Excavation
Figure 7	Area of Groundwater Treatment

List of Appendices

Appendix A	Responsiveness Summary
------------	------------------------

LIST OF ACRONYMS and ABBREVIATIONS

ARAR	Applicable or Relevant and Appropriate Regulations
ATV	Alternate Toxicity Value
BDL	Below the laboratory Detection Limit
BHHRA	Baseline Human Health Risk Assessment
bls	Below land surface
bgs	Below ground surface
CAR	Corrective Action Report
CERCLA	Comprehensive Environmental Response, Compensation, and Liability Act of 1980
COC	Contaminant (or Chemical) of Concern
COPC	Contaminant of Potential Concern
COPEC	Contaminant of Potential Ecological Concern
CSF	Carcinogenic Slope Factor
cys	cubic yards (also see yd ³)
DQO	Data Quality Objectives
EPA	United States Environmental Protection Agency
EPA-OTS	EPA Region 4 Office of Technical Services
EPS	Exposure Pathway Scenarios
ERA	Ecological Risk Assessment
EPC	Exposure Point Concentration
ESD	Explanation of Significant Differences
ESI	Expanded Site Inspection
ESV	Ecological screening values
FDEP	Florida Department of Environmental Protection
HEAST	Health Effects Assessment Summary Tables

HI	Hazard Index
HQ	Hazard Quotient
GCTL	Florida Groundwater Cleanup Target Level
IRIS	Integrated Risk Information System
LOAEL	Lowest Observed Adverse Effects Level
MCL	Maximum Contaminant Level
MEP	Maximum Extent Practicable
mg/kg	milligrams per kilogram or parts per million (ppm)
NCEA	National Center for Environmental Assessment
NCP	National Contingency Plan
NOAA	National Oceanic and Atmospheric Administration
NOAEL	No Observed Adverse Effects Level
NPL	National Priority List
OUI	Operable Unit 1
O&M	Operation and Maintenance
PA	Preliminary Assessment
PAH	Polycyclic Aromatic Hydrocarbons
PCB	Polychlorinated Biphenyls
PCOPEC	Preliminary Contaminant of Potential Ecological Concern
ppb	parts per billion
PRP	Potentially Responsible Party
ppm	parts per million
PRG	EPA Region 9 Preliminary Remediation Goals
RAO	Remedial Action Objectives
RBC	EPA Region 3 Risk Based Concentrations
RBCA	Risk Based Corrective Action

RCRA	Resource Conservation and Recovery Act
RI/FS	Remedial Investigation/Feasibility Study
RG	Remedial Goals (i.e., cleanup levels)
ROD	Record of Decision
RPM	Remedial Project Manager
SARA	Superfund Amendments and Reauthorization Act of 1986
SAS	Superfund Alternative Site
SCTL	Florida Soil Cleanup Target Level
SDWA	Safe Drinking Water Act
SESD	EPA Region 4 Science and Ecosystem Support Division
SI	Site Inspection
SQL	Sample Quantification Limit
SVOCs	Semi-Volatile Organic Compounds
TAL	Target Analyte List
TAT	Technical Assistance Team
TCL	Target Compound List
TCLP	Toxicity Characteristic Leaching Procedure
TEQ	Toxicity Equivalence Quotient
ug/kg	micrograms per kilogram
ug/L	micrograms per Liter
US	United States
US FWS	United States Fish and Wildlife Service
VOCs	Volatile Organic Compounds
yd ³	cubic yards
XRF	X-ray fluorescence
<	less than

Part 2: THE DECISION SUMMARY

1.0 Site Location and Description

The Landia Chemical Company Site (the Site) is located at 1405 Olive Street in Lakeland, Polk County, Florida (Figure 1). The EPA Site Identification Number is FLD042110841. Pesticide blending and formulating operations were conducted on the Landia property from 1945 until 1987 by three different companies (Standard Spray and Chemical (1945-1976), Agrico Chemical Company (1976-1977) and Landia Chemical Company (1977-1987)). These operations resulted in the release of various pesticides, metals and volatile organic compounds (VOCs) into the environment. The Landia property is currently used by an unrelated entity for the storage of construction forms. Access to the Landia property is restricted by chain-link fencing and locked gates.

Also being addressed as part of the Site are contaminants on the property located just west of the Landia property at 1607 Olive Street. Historical operations at the Landia facility included the use of portions of the property, formerly owned by Florida Favorite Fertilizer (FFF), for the storage of bulk sulfur. Storage of this sulfur increased the acidity of the groundwater which likely enhanced the mobility of the pesticides and metals in the groundwater. FFF conducted fertilizer blending operations on the FFF property from the mid 1930's until the property was sold in 2006. The current owner conducts operations similar to those conducted by FFF. Only bulked fertilizer products (potassium, nitrogen and phosphorous) are blended or stored at the FFF property. However, operations at this facility have resulted in the release of various nutrients particularly nitrates which are present in the groundwater above health based standards and are co-mingled with pesticide contamination from the Landia property. Access to the FFF property is restricted by chain-link fencing and locked gates.

The Site is primarily surrounded by industrial and commercial properties as shown in Figure 2. The closest area of residential properties is located just south of the Site on the south side of Olive Street. West of the Site are the Tifton and the Arapahoe Triangle properties (industrial). Pesticide manufacturing has been documented to have occurred on the Tifton property where EPA conducted a removal action in 2004. Immediately to the east of the Landia property is a commercial/light industrial property which fronts Olive Street. Olive Street borders the Site on the south. Land immediately south of the Landia property is owned by the Onesiphorus Gospel of Christ church and a car repair business. North of the Site, running east-west is an active railroad corridor. To the north of the rail road right-of-way are several commercial/light industrial properties that front George Jenkins Boulevard. These properties include the Lakeland Industrial Park, Southern Milling & Lumber Company, Lineberger Fuel Company, and the YMCA Golf Course.

Since 1999, EPA has been the lead agency in charge of ensuring the contamination at the site is addressed through the Superfund program to be protective of human health and the environment. The Florida Department of Environmental Protection (FDEP) is the support agency representing the interests of the State of Florida. The investigation and cleanup of the Site has been funded by the Potentially Responsible Parties (PRPs), Agrico and Florida Favorite Fertilizer (owned by PCS Joint Ventures, Inc.(PCS JV)). Additional PRPs may be named in the future. In February 2000 EPA proposed the Site for listing on Superfund National Priorities List (NPL) because of the detections of metals and organic pesticides in the soil and groundwater. The Site was finalized on the NPL in May 2000.

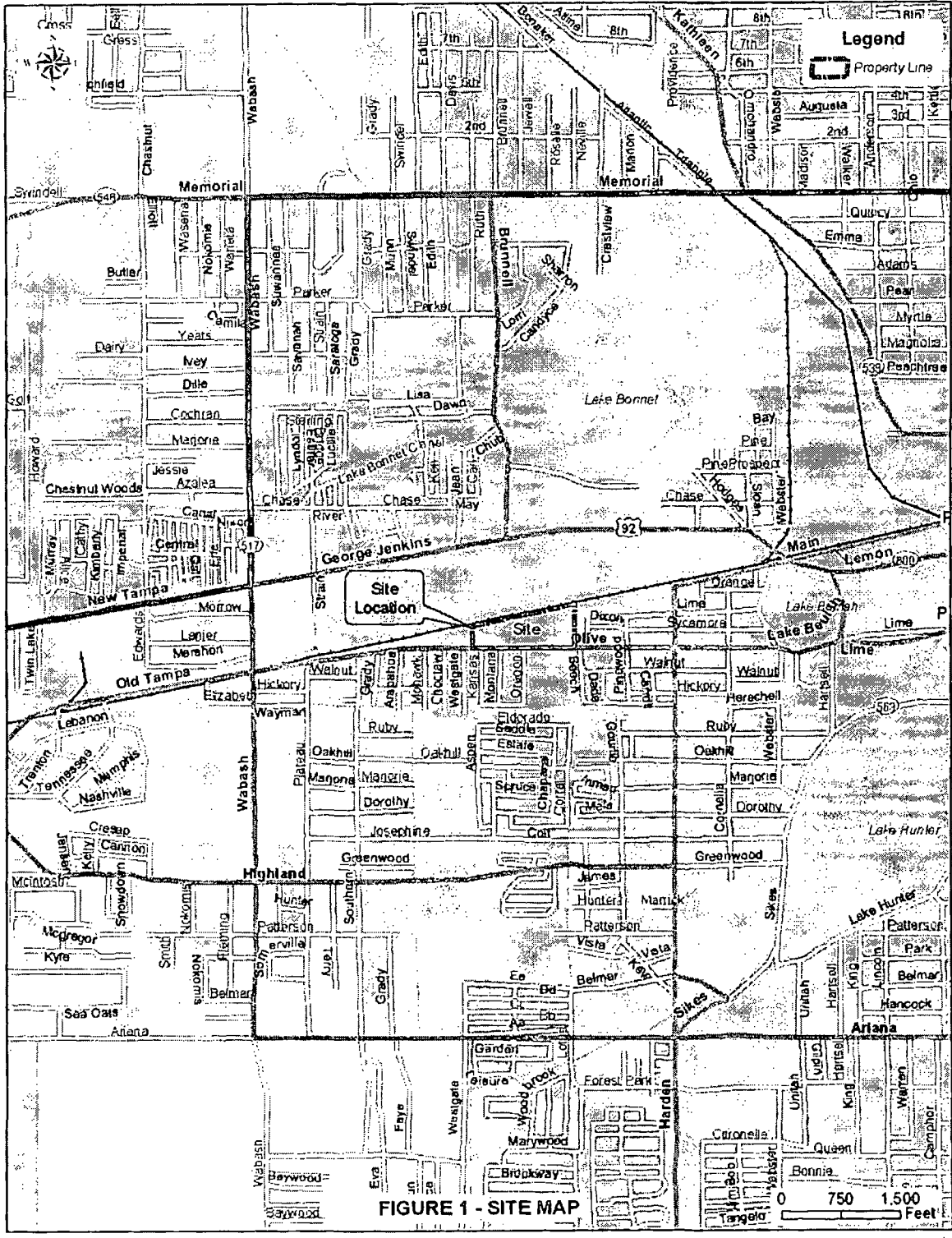

FIGURE 1 - SITE MAP

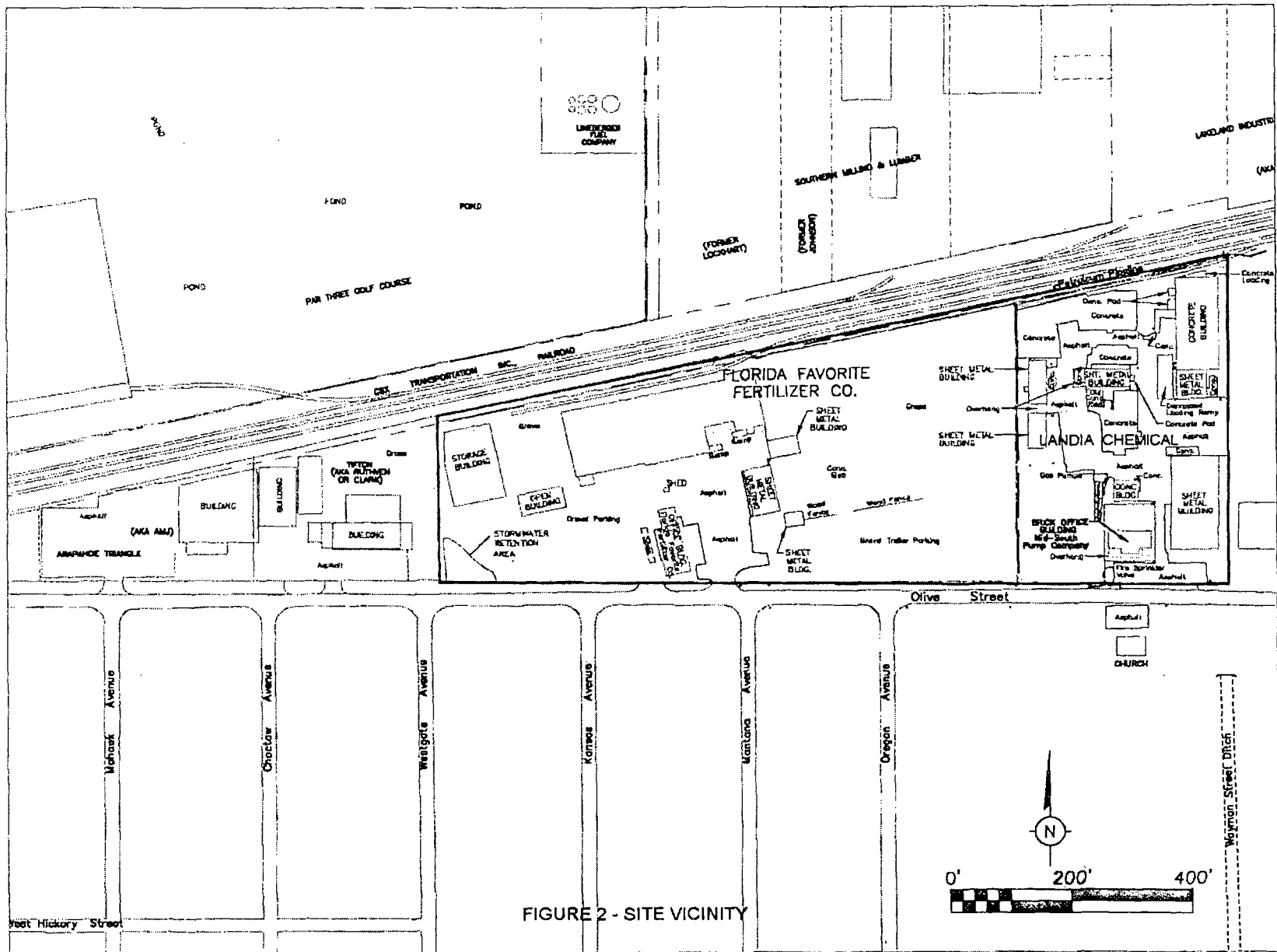

FIGURE 2 - SITE VICINITY

2.0 Site History and Enforcement Activities

2.1 History of Site Operations

The property currently owned by Landia Chemical Company at 1405 Olive Street was used for the manufacturing of various pesticides over 42 years of operation. Standard Spray and Chemical Company (SSCC) operated at this location from approximately October 1945 until November 1976. The property was sold to Agrico Chemical Company in November 1976, and then sold to Landia Chemical Company in November 1977 who operated at the facility until 1987. The property is currently leased to a manufacturer of concrete forms who uses the property primarily for storage. The principal chemicals blended or stored at the Landia property during the pesticide manufacturing operations included organophosphate pesticides, organochlorine pesticides, and various metals used in pesticide formulation.

FFF Company began fertilizer blending operations on the FFF property located at 1607 Olive Street sometime after 1935. FFF purchased the current eastern portions of the property from the City of Lakeland in 1945. FFF was incorporated after 1946. In 1992, FFF conveyed this property for a limited partnership interest in PCS JV. In 2006, PCS JV sold the property to Wedgeworth, Inc, who is the current owner and operates a similar fertilizer blending and storage facility.

2.2 Prior Federal and State Site Investigations and Removal Actions

Many site investigations and two removal actions have been conducted at the Site by FDEP, EPA and the PRPs in order to determine the nature and extent of contamination. During these investigations, many soil, sediment, surface water, and groundwater samples were collected and numerous permanent groundwater monitoring wells were installed.

The first known environmental sampling at the Site was conducted in 1983 by NUS Corporation under contract with the EPA. Later in 1983, FDEP conducted an investigation of the Wayman Street Ditch. A warning notice was issued by FDEP to the Landia Chemical Company due to the discovery of pesticide compounds in the ditch. In November 1983, Landia Chemical Company coordinated the removal of impacted sediments from the first 1,000 feet (ft) of the ditch (136 tons of sediment removed from ditch and 10 tons from the Landia property).

After the 1983 removal action was completed, additional contamination assessments were conducted either by the FDEP or by the PRPs under FDEP oversight. These contamination assessments were summarized in three reports: Contamination Assessment Report, Landia Chemical Company, (CH2MHill 1988); Contamination Assessment Report, Landia Chemical Company, (Blasland Bouck & Lee 1997); and Olive Street Contamination Study, Olive Street, Lakeland Florida; (IT Corporation 1999).

In April 1992, an underground pipeline located near the railroad in the northeast corner of the FFF property and operated by Central Florida Pipeline (CFPL), ruptured and spilled approximately 6,200 gallons of Jet-A fuel onto the Landia property between buildings in the western portions of the Site and in the southwestern corner. The product accumulated in the low elevation areas in the northern portion of the FFF property. After a Site assessment was conducted, approximately 4,500 gallons of the petroleum product and 10 cubic yards (cy) of soil were removed by CFPL contractors (ARCADIS 2003).

In June 1999, the EPA conducted an investigation of the extent of contamination in residential areas surrounding the Site. Using the results of this investigation and past contamination assessments, the Florida Department of Health (FDOH) issued a Public Health Assessment in February 2000 which concluded there was no apparent public health hazard in the residential areas and that elevated levels of contaminants were isolated and generally confined to the non-residential areas. FDOH recommended that Site access be restricted to prevent exposure to on-site surface soils and area groundwater not be used for drinking purposes. In July 1999, FDOH issued a Contaminated Groundwater Advisory for 10 blocks of the residential area south of the Site (south of Olive Street, west of Beech Avenue, east of Southern Avenue and north of the Wayman Street ditch). This advisory, in combination with the Southwest Florida Water Management District (SWFWMD) efforts to restrict permits for new wells in or near the contaminated groundwater plume precludes the public from accessing groundwater impacted by site activities on or surrounding the Site.

In late 1999, in response to findings from sampling conducted by EPA, PCS JV and Agrico Chemical Company entered into an agreement with EPA to excavate and dispose of Site soils and Wayman Street Ditch sediments that exceeded levels which posed an unacceptable short-term exposure risk. Removal of soils from the Landia property was coordinated by URS Corporation (URS, 2001) on behalf of Agrico Chemical Company and removal of soils from the FFF property, a small area of the Church property south of Olive Street, and the first 600 ft of the Wayman Street Ditch was coordinated by ARCADIS on behalf of PCS JV. Approximately 2,650 tons of soil were removed from the Landia property and 1,600 tons of soil were removed from the FFF property. In addition, approximately 510 tons of soil and sediment were removed from the off-site areas and the ditch. This action was completed in early 2001.

From 2000 to 2003, the PRPs conducted the Remedial Investigation (RI) and two risk assessments, under EPA oversight, which delineated the horizontal and vertical impacts to soil, sediment, air, surface water and groundwater from chemicals of potential concern (COPCs) and evaluated the risk associated with these contaminants. The Final RI Report was submitted to EPA in February 2003 (ARCADIS, 2003) and approved by EPA in July 2003. In order to evaluate the COPCs, refine the list to chemicals of concern (COCs), and evaluate the human health risk associated with the COCs, a Human Health Risk Assessment (HHRA) was conducted. The HHRA was submitted to EPA in July 2003 (ENSR, 2003a) and approved in August 2003. In order to evaluate the potential ecological risks due to exposure, a Screening Level Ecological Risk Assessment (SLERA) was conducted. The SLERA report (ENSR 2002) was submitted to EPA and approved in December 2003.

2.3 History of CERCLA Enforcement Activities

In 1999, EPA assumed oversight responsibilities for the Site and entered into an Administrative Order on Consent (AOC) with PCS JV to conduct a Remedial Investigation and Feasibility Study (RI/FS) at the Site. This purpose of this investigation was to further delineate the nature and extent of all Site-related contaminants, to evaluate the risks associated with these contaminants and to evaluate potential cleanup alternatives. This AOC was signed by PCS JV on October 21, 1999. In 2000 Agrico signed the AOC and has participated in conducting the RI/FS.

In May of 2000, EPA entered into another AOC with PCS JV and Agrico to perform a removal action at the Site to excavate and dispose of contaminated soil and Wayman Street ditch sediment. The purposed of the removal action was to abate the imminent and substantial endangerment to the public health, welfare or the environment posed by the Site. Both of the AOCs required PCS JV and Agrico to reimburse the response costs incurred by the United States in connection with the Landia Chemical Company site.

3.0 Community Participation

The Community Relations Plan for the Site was approved in March of 2000. EPA implemented the plan by involving the community in the all the work being conducted by the remedial and removal programs. EPA issued many fact sheets and letters, communicated with the local newspaper (the Ledger), developed videos and held public availability sessions to ensure the public was informed and was allowed to participate in the process. The following list summarizes the major community relations activities.

- September 1999 – EPA and the Florida Department of Health held the first Open House meeting to kick off the upcoming remedial investigation and discuss the findings of the draft public health assessment.
- February 2000 – EPA held another Open House meeting to present results of the sampling in the Westgate neighborhood and to discuss the upcoming removal action.
- February 2000 – EPA issued a Fact Sheet discussing how the recommendations of the Public Health Assessment would be addressed.
- March 2000 – The Florida Department of Health issued a Fact Sheet discussing the results of fish tissue sampling in the Highland Street pond.
- March 2000 - EPA approved the final Community Relations Plan and placed it in the public library.
- June 2000 - EPA prepared a video discussing the upcoming remedial and removal activities and placed it in the public library.
- July 2000 – EPA held another Open House meeting to discuss the upcoming removal action and the progress of the remedial investigation.
- September 2000 – EPA and the Florida Department of Health issued a Fact Sheet to update the Lakeland community on the progress of the removal action and the results of cancer rate and vegetable studies.
- March 2001 – EPA prepared another video discussing how the removal action was conducted and how the remedial investigation will proceed.

The RI/FS Report and Proposed Plan for the Landia Chemical Company Site in Lakeland, Florida, were made available to the public in June 2007. They can be found in the Administrative Record file and the information repository maintained at the EPA Docket Room in Region 4 and at the Lakeland Public Library, 100 Lake Morton Drive, Lakeland, Florida. The notice of the availability of these two documents was published in The Ledger on June 23, 2007. A public comment period was held from June 25, 2007 to July 25, 2007. In addition, a public meeting was held on July 10, 2007, to present the Proposed Plan to the local community in Lakeland, Florida. At this meeting, representatives from EPA answered questions about the Site and the preferred remedial alternative. EPA's response to comments received during this public comment period is included in the Responsiveness Summary, which is part of this Record of Decision.

4.0 Scope and Role of Response Action

As is typical with many Superfund sites, the problems at the Landia Chemical Site are varied and complex. As a result, EPA has organized the work into two operable units (OUs). This ROD selects the final remedy for Operable Unit 1 (OU1) and provides an interim action for OU2.

- **Operable Unit 1: Soil Contamination**

During the two previous removal actions, a large amount of contaminated soil was excavated and disposed of in an off-site landfill. In the final remedial action, all remaining soil with site-related contaminants above selected, health based cleanup criteria or at levels which continue to impact the groundwater (which are noted in Table 5) will be excavated and disposed of in an off-site landfill. The excavated areas will be refilled with limerock and clean soil and then seeded with grass. The purpose of refilling some of the excavated areas with limerock will be to take advantage of the limerock's beneficial buffering properties in an effort to raise the pH levels in the subsurface soil and groundwater. Areas to be potentially refilled with limerock and soil will be determined in the remedial design.

As described in the Human Health Risk Assessment, contact with Contaminants of Concern (COCs) present in the soil and groundwater in certain areas of the Site pose a risk to human health because concentrations are above applicable or relevant and appropriate requirements (ARARs) or are above EPA's acceptable level of risk (1×10^{-4}). The purpose of this final action is to prevent current or future exposure to soil contamination which poses a risk greater than 1×10^{-6} which has been determined by EPA to be an ARAR in the State of Florida. This will be the final response action for this Operable Unit.

- **Operable Unit 2: Groundwater Contamination**

In-situ chemical oxidation and in-situ biodegradation will be used together to treat the areas of the most contaminated groundwater after the OU1 remedy is implemented and the contaminated soil removed. The purpose of this interim action is to quickly reduce the levels of pesticides and nitrates in the groundwater to levels that can be allowed to naturally degrade. During the remedial design, treatability studies will be conducted to determine which areas are most suited for in-situ chemical oxidation and which areas are most suited for in-situ biodegradation. In order to establish a manageable area to conduct this interim action, the areas of groundwater with contaminant levels greater than the State of Florida's Natural Attenuation Default Criteria (NADCs) were evaluated. Based on this evaluation, a boundary was established to include all areas of groundwater with contaminants greater than the NADCs north of Olive Street on the Landia and FFF properties and the property just west of the FFF property. This boundary limits the implementation of the interim action to the industrial areas, minimizes the impact to the nearby residential areas and also focuses initial groundwater cleanup activities towards the Site areas with the highest levels of groundwater contamination. It is anticipated that by treating these areas through this interim action, the overall groundwater concentrations of site-related COCs will begin to decline. Monitoring will occur on a yearly basis and at the five-year review timeframe to evaluate the effectiveness of the interim action for this Operable Unit. Based on these evaluations, a final action to treat all remaining groundwater contamination above the cleanup goals will be chosen in a final ROD.

5.0 Site Characteristics

5.1 Site Features, Topography, Surface Water and Drainage

The Site consists primarily of two properties encompassing 13 acres located on a topographic ridge that decreases in elevation to the west, north and south. There are no major surface water bodies in the vicinity of the Site. The nearest substantive surface water is approximately 1,600 feet north of the Site. Man-made retention ponds exist on the golf course property, approximately 500 feet northwest of the Site and on the southwest corner of the FFF property. The Site consists of buildings, paved and gravel areas and grassy areas. Stormwater runoff from the FFF property is currently directed to the FFF retention pond and from the Landia property to a sediment trap on the southeast corner of the Landia property. The stormwater from the Landia property is then conveyed to the Wayman Street Ditch stormwater system, a portion of which is concrete lined.

5.2 Site Hydrogeology

The Site conceptual model (Figure 3) encompasses an aquifer system comprised of a surficial aquifer and a deeper aquifer separated by a confining unit. The surficial aquifer has been described as two zones: an upper sandy "water table" zone with a thickness of 15 to 20 ft and an underlying "basal" zone that has higher clay content. These zones are hydraulically connected and the boundary between the two zones is a gradual transition. The total thickness of the surficial aquifer is approximately 30 to 40 ft, and in places up to 50-ft thick. The surficial aquifer is not used as a source of drinking water, but has in the past supplied irrigation water. The depth to groundwater at the Site varies seasonally, but is shallow and generally averages 3-ft below land surface (bls).

In general, the Site is on a gentle ridgeline that functions as a groundwater flow divide. Groundwater flow from the Site is downward and lateral to the north, south and west in a semi-radial flow pattern. The horizontal gradient is approximately 0.01 feet per foot (ft/ft). The underlying confining unit of the surficial aquifer consists of a clay-rich matrix with interbedded zones of sandy clay, phosphatic clay and weathered limestone cobbles which is assumed to be part of the Hawthorne Group. Beneath the confining unit is the Floridan aquifer, a regionally significant water supply source. No drinking water wells or Floridan municipal or public water supply wells were reported within a mile of the Site.

5.3 Nature and Extent of Contamination

Five groups of contaminants have been identified in environmental media at the Site. Examples of Contaminants of Concern (COCs) belonging to each group are identified below, with their associated potential health effects and routes of possible exposure. As described below further in Sections 5.3.1 and 5.3.2, various constituents have been found on-site which are not known to have been released due to operations on either the Landia property or the FFF property, and these constituents are not considered COCs at this Site.

- **Chlorinated Pesticides:** Examples of chlorinated pesticides that are COCs at the Site include chlordane, DDT, toxaphene and various isomers of benzene hexachloride (BHC) including alpha-BHC, beta-BHC, delta-BHC and gamma BHC (lindane). These chemicals are all organochlorine compounds widely used after WWII as agricultural pesticides. DDT and other chlorinated pesticides are suspect human carcinogens. Chlorinated pesticides can be absorbed into the body by skin contact or ingestion. Short-term exposure to chlorinated pesticides affects the central nervous system. Direct contact

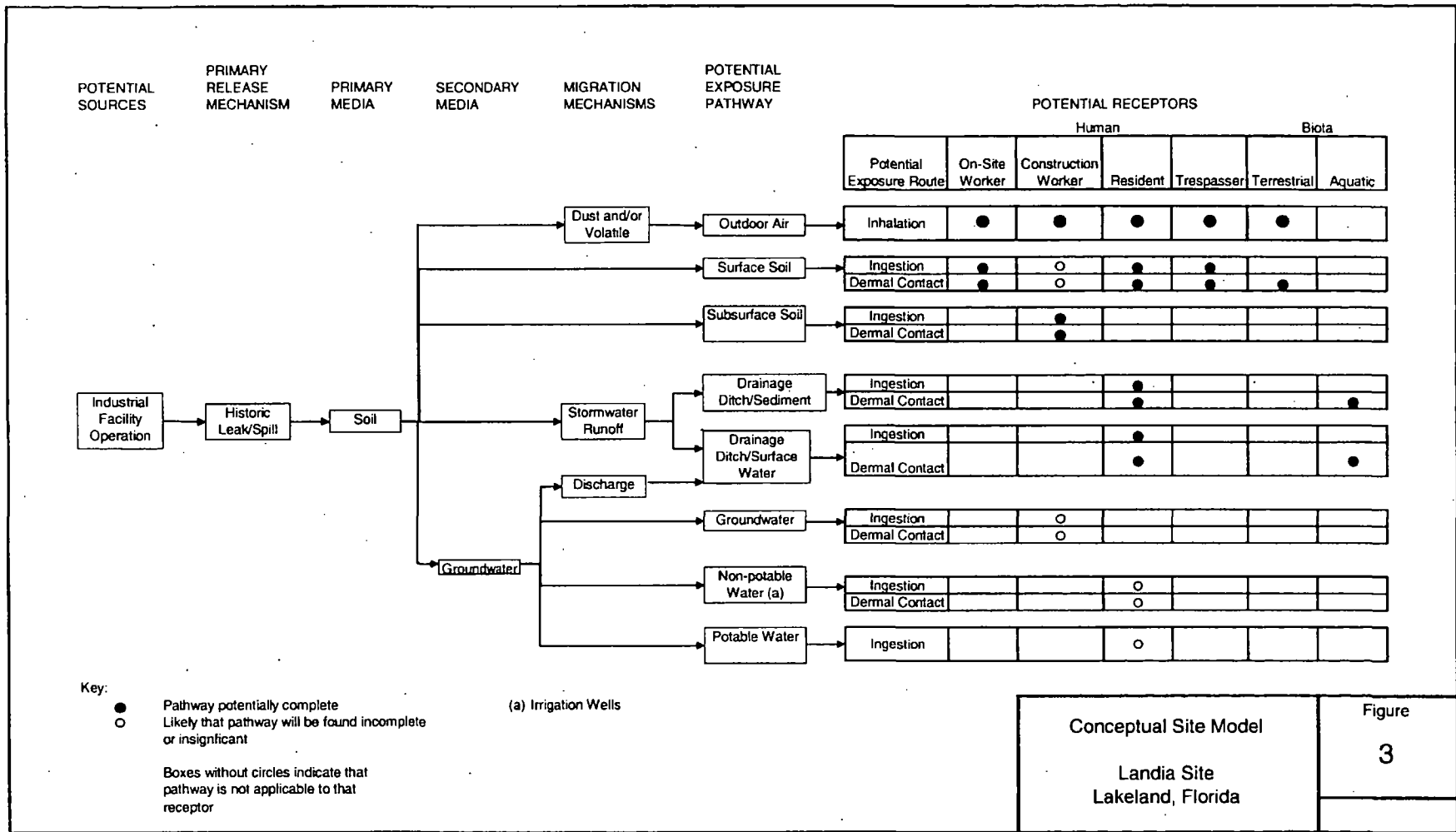

may cause rashes or irritation of the eyes, nose or throat. Long-term exposure at low levels causes some changes in the level of liver enzymes in humans.

- **Semi-volatile Organic Compounds (SVOCs):** SVOCs include various organic compounds composed of combinations of closed (benzene) rings, together with attached molecular structures. They occur naturally in coal; petroleum, tars, pitches, and woods, and may be formed in fires involving heavy hydrocarbon materials. Examples of SVOC's that are COCs on-site are 1,2,4-Trichlorobenzene, 2,4-Dichlorophenol, 2-Chlorophenol, and 4-Nitrophenol. The Department of Health and Human Services (DHHS) has determined that some SVOCs may reasonably be expected to be carcinogens. Some people who have breathed or touched mixtures of SVOCs and other chemicals for long periods of time have developed cancer. Some SVOCs have caused cancer in laboratory animals when inhaled (lung cancer), ingested (stomach cancer), or had them applied to their skin (skin cancer). As a class they should be treated as carcinogens and exposures should be kept to a minimum. SVOCs are generally solids and not very volatile, making dust or smoke the likely route of exposure.
- **Volatile Organic Compounds (VOCs):** Organic solvents are the group of volatile compounds or mixtures found at the Site. They are relatively stable chemically and exist in the liquid state at temperatures of approximately 32° to 82°F. Organic solvents are used for extracting, dissolving, or suspending materials such as fats, waxes, and resins that are not soluble in water. Solvents are used in paints, adhesives, glues, coatings, and degreasing/ cleaning agents. Inhalation and skin absorption are the primary routes of solvent uptake into the peripheral blood, which begins within minutes of the onset of exposure. Organic solvents undergo biotransformation or they accumulate in the lipid-rich tissues such as those of the nervous system. Solvent inhalation may cause effects ranging from an alcohol-like intoxication to narcosis and death from respiratory failure, with a spectrum of intermediate symptoms that include drowsiness, headache, dizziness, dyspepsia, and nausea. Examples of VOCs that are COCs on-site are xylene (also called methyl toluene), methylene chloride, and hexachlorobenzene. The DHHS, the International Agency for Research on Cancer (IARC) and the EPA have determined that benzene is carcinogenic to humans. Both the IARC and the EPA have found that there is insufficient information to determine whether or not xylene and ethylbenzene are carcinogenic. Studies in humans and animals generally indicate that toluene does not cause cancer.
- **Metals:** Metals that are COCs at the Site include arsenic, cadmium, chromium, and lead used in the formulation of dispersants and chelating agents; solvents; emulsifiers; spray oils; and wetting agents. Metals can enter the body by ingestion, inhalation, or direct dermal contact. Most arsenic that is absorbed into the body is converted by the liver to a less-toxic form that is efficiently excreted in the urine. Consequently, arsenic does not have a strong tendency to accumulate in the body except at high exposure levels. Inorganic arsenic has been recognized as a human poison since ancient times, and large doses can produce death. Lower levels of exposure may produce injury in a number of different body tissues or systems: these are called "systemic" effects. Cadmium, when ingested at very high levels, will severely irritate the stomach, leading to vomiting and diarrhea. Ingestion of low levels of cadmium over a long period of time may lead to kidney damage and fragile bones. Skin contact with cadmium is not known to cause health effects in humans or animals. Cadmium is a suspected inhalation carcinogen according to the DHHS. Long term exposures to high or moderate levels of chromium (VI) cause damage to the nose (bleeding, itching, sores) and lungs, and can increase your

risk of non-cancer lung diseases. Ingesting very large amounts of chromium can cause stomach upsets and ulcers, convulsions, kidney and liver damage, and even death. The early symptoms of lead poisoning, as a result of overexposure (either through ingestion or inhalation) include fatigue, sleep disturbance, headache, aching bones and muscles, digestive irregularities, abdominal pains, and decreased appetite. Chronic overexposures to lead affect the central nervous system and male and female reproductive systems. Lead has also been identified as a fetotoxin.

- **Other Inorganic Constituents:** Other inorganic constituents that are COCs at the Site include sulfate and nitrate/nitrite. Sulfate is a substance that occurs naturally in drinking water. Health concerns regarding sulfate in drinking water have been raised because of reports that diarrhea may be associated with the ingestion of water containing high levels of sulfate. Of particular concern are groups within the general population that may be at greater risk from the laxative effects of sulfate when they experience an abrupt change from drinking water with low sulfate concentrations to drinking water with high sulfate concentrations. Sulfate in drinking water currently has a secondary maximum contaminant level (SMCL) based on aesthetic effects (i.e., taste and odor). Nitrate (NO_3) and nitrite (NO_2) are naturally occurring inorganic ions, which are part of the nitrogen cycle. Microbial action in soil or water decomposes wastes containing organic nitrogen first into ammonia, which is then oxidized to nitrite and nitrate. Because nitrite is easily oxidized to nitrate, nitrate is the compound predominantly found in groundwater and surface waters. Contamination with nitrogen-containing fertilizers, including anhydrous ammonia as well as animal or human natural organic wastes can raise the concentration of nitrate in water. Infants younger than 4 months of age who consume water with high nitrate levels are prone to developing acute acquired methemoglobinemia from nitrate exposure.

5.3.1 Source Materials and Soil Impacts

Historical operations at the Landia facility involved various amounts of organophosphates, organochlorines, sulfur products, and various metals used in pesticide formulation. As part of the manufacturing operations, dispersants and chelating agents; solvents; emulsifiers; spray oils; and wetting agents were also used. The manufacturing/processing area was located in the rear (north side) and central portions of the property. A former building in the central portion of the property was reportedly used as a maintenance shop. Interior areas of the facility were used for exterior storage, and during historic operations, these areas were unpaved. Several aboveground storage tanks existed. Unlined ponds along the southwestern and western boundaries of the property previously existed and received facility runoff.

The 2000 Removal Action removed much of the primary (operational) sources of pesticides and metals soil contamination at the Landia property. Secondary sources (soil impacted with pesticides and metals that may leach or be transported by wind or runoff) were either removed or covered. Impacted soil remains at isolated locations on the Landia property and may pose potential sources of impacts to groundwater. Much of the impacted soil is covered by clean soil or under concrete foundations or other locations that are not readily accessible to Site visitors/workers.

Operations at the former FFF property involve the blending of basic fertilizer products (phosphorus, potassium, nitrogen). Raw materials are delivered via railcar at the rear (north side) of the facility and transported to the main storage and formulation complex. This complex has existed in various configurations and has covered a majority of the northwestern portion of

the property. A maintenance shop has been located in the approximate center of the facility. When Standard Spray and Chemical Company operated on the Landia property, the northeastern portion of the FFF property was used to store elemental sulfur on the ground prior to transfer to the Landia property. During the 2000 Removal Action, much of the source areas were removed or covered including the removal of a significant amount of sulfur. However, impacted soil with COCs above cleanup goals noted in Table 5 remain at the FFF property and represent a potential source of COC impacts to groundwater.

The Remedial Investigation (RI) was conducted from 2000 to 2003 to determine the nature and extent of the contamination at the Site. The RI employed a biased sampling approach based on data collected from previous EPA and FDEP assessments and removal actions. Soil, groundwater, sediment, and surface water were sampled to delineate the nature and extent of contamination on the Landia and FFF properties, areas south of Olive Street, and the Wayman Street Ditch.

The RI concluded that areas of soil contamination above the cleanup goals found in Table 5 are essentially limited to pesticides and metals. The distribution of these soil impacts at both the 0-2 feet and 0-3 feet range is shown in Figure 4. The COCs and their respective maximum concentrations detected in surface and subsurface soil on the Site are listed below.

- Benzene hexachloride (BHCs; more appropriately known as hexachlorocyclohexane) [1,900 mg/kg]
- 4,4'-dichlorodiphenyldichloroethane (DDD) [1,200 mg/kg]
- 4,4'-dichlorodiphenyldichloroethylene (DDE) [280 mg/kg]
- 4,4'-dichlorodiphenyltrichloroethane (DDT) [2,500 mg/kg]
- Dieldrin [140 mg/kg]
- Aldrin [18.4 mg/kg]
- Chlordane [2,100 mg/kg]
- Heptachlor [19.2 mg/kg]
- Heptachlor epoxide [12 mg/kg]
- Toxaphene [29,000 mg/kg]
- Arsenic [27.4 mg/kg]
- Cadmium [24.2 mg/kg]
- Chromium [24.4 mg/kg]
- Dioxin [662.922 pg/g TCDD equivalent]
- Lead [77.4 mg/kg]

Based on the data collected during previous studies at the Site, approximately 13,289 and 7,980 cubic yards of soil containing COCs above cleanup goals noted in Table 5 remain at the FFF and former Landia properties, respectively for a total of 23,290 cubic yards of contaminated soil.

Other constituents found on-site are not known to have been released due to operations on either the Landia property or the FFF property. As an example, PAHs sporadically detected in on-site

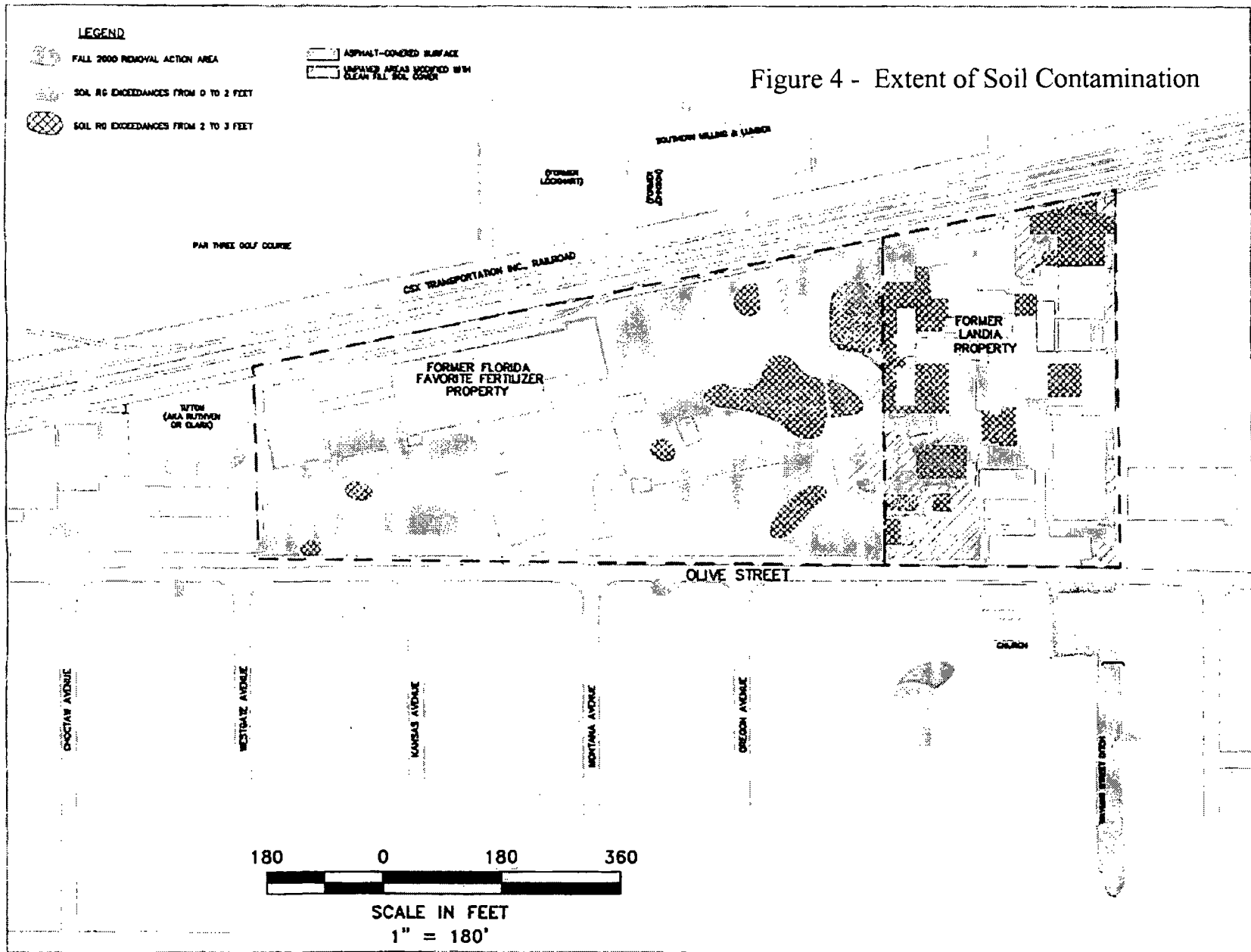

soil are not associated with fertilizers or pesticides, but are associated with combustion sources such as railroads, automobiles and fuels.

In the residential area, isolated exceedances of the State of Florida's residential Soil Cleanup Target Level (SCTLs) were sporadic in distribution and exhibited no clear relation to the Site. A limited number of chlorinated pesticide compounds and metals were detected above the residential SCTLs in the residential surface soils (0 to 2 ft). The following COCs were detected in surface soil within the residential area and their maximum concentrations are provided in brackets.

- Dieldrin [0.54 mg/kg]
- Chlordane [5.4 mg/kg]
- Heptachloride epoxide [0.28 mg/kg]
- DDT [110 mg/kg]
- Arsenic [3.0 mg/kg]
- Lead [230 mg/kg]

5.3.2 Groundwater Impacts

Available data indicate that COCs (primarily chlorinated pesticides, sulfates and nitrates) have migrated through the shallow soils and impacted the surficial aquifer. The data indicate that impacts to groundwater are limited to the surficial aquifer zone, and that an aquitard prevents site-related impacts from reaching the underlying Floridan Aquifer System. COCs which have been detected in groundwater above their respective screening values are listed below along with their maximum concentrations.

- Chlordane [6.9 µg/L]
- DDD [16 µg/L]
- DDE [1.4 µg/L]
- DDT [16 µg/L]
- 4-nitrophenol [6,100 µg/L]
- Arsenic [2,100 µg/L]
- Cadmium [390 µg/L]
- Chromium [400 µg/L]
- Dieldrin [0.23 µg/L]
- Lead [2.6 mg/L]
- Methyl chloride [54 µg/L]
- Toxaphene [62 µg/L]
- Total xylenes [3,300 µg/L]
- 1,2,4-trichlorobenzene [230 µg/L]
- 2,4-dichlorophenol [2.2 µg/L]

The following sections briefly discuss the COCs found and the extent of impacts to groundwater above cleanup goals shown in Table 5 at the Site.

Chlorinated Pesticides Distribution

Figure 5 presents the distribution of BHC isomers in the surficial aquifer. The BHC plume extends only a short distance to the east (onto the adjacent property), to the north to George Jenkins Blvd., to the west to the Tifton property, to the southwest past Southern Avenue and to the South to just north of the Wayman Street Ditch. Other chlorinated pesticides have been sporadically detected in wells within the footprint established by the site-related BHC impacts (Arcadis 2003). Contributions to the southwest portion of the BHC plume may also be emanating from unrelated off-Site sources such as the Tifton property.

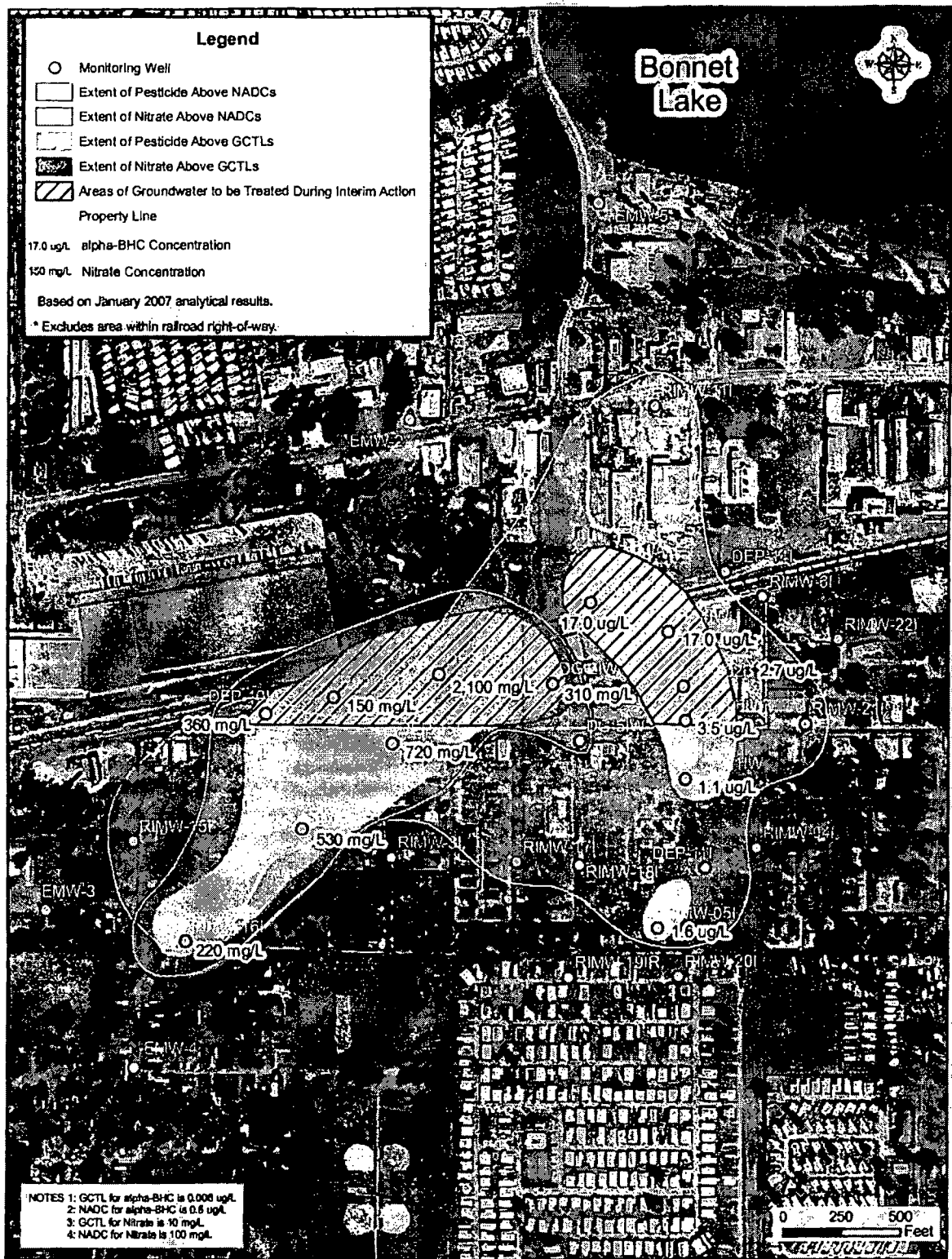

Figure 5 – Extent of Groundwater Contamination

VOC Distributions

As detailed in the RI Report, various VOCs were detected in the surficial aquifer. Most of the benzene, toluene, ethylbenzene and total xylenes (BTEX) in the surficial aquifer were found near the property boundary between the Landia and FFF properties. As indicated in the RI report, xylene derivatives and methylene chloride were used at the Site. However, it is believed that the majority of the mass of xylene in groundwater at the Site is attributable to a well documented non-Site release from the CFPL pipeline in 1992. Xylene is a component of jet fuel and is commonly found in higher concentrations in groundwater compared to other BTEX components at jet fuel spill sites. At the Landia Site, BTEX occurrence in groundwater follows the extent of the jet fuel release from the CFPL pipeline in the railroad corridor immediately north of the Site, and jet fuel accumulation between the FFF and Landia properties. The BTE impacts have thus far been considered non site-related. Chlorinated VOCs were detected at low levels in the surficial aquifer on the Landia property, however, they appear to originate from an unknown source east of the Site and are considered non site-related. The RI report concluded that the VOCs detected in groundwater other than xylenes in the off-site study areas (including Church and Tifton properties) were considered non site-related plumes emanating from potential multiple off-site sources.

SVOC Distribution

The SVOC plume is similar in extent to the VOC plume, and the key exceedances were for certain phenolic and/or naphthalene compounds. Separate and single exceedances of pentachlorophenol and bis-(2-ethylhexyl) phthalate were observed in off-site wells and therefore are not considered site-related. As indicated in the RI report, the presence of phenol to the east of the Landia property and in the southern portions of the Church property suggests a possible off-site source for the phenolic compounds.

Key Inorganic Constituents

The key inorganic constituents detected in groundwater other than metals which are described below are nitrate/nitrite and sulfate. Nitrates were detected in excess of GCTLs in the central and western portions of the FFF property, and these appear to extend to the west underneath the Tifton property and the Arapahoe Triangle (Figure 5) and southwest to the Wayman Street Ditch. Both nitrate and nitrite are considered site-related, but nitrite could be a daughter product of nitrate possibly from the denitrification process that might be naturally occurring.

In the surficial aquifer, exceedances of the Secondary MCL/GCTL for sulfate (250 mg/L) were found in an apparently continuous plume beginning underneath the FFF and Landia properties and traversing to the west underneath the Arapahoe Triangle properties. The sulfate plume extends to the north to George Jenkins Boulevard and to the south to Wayman Street Ditch.

pH Distribution

As discussed in the RI report, areas of low pH groundwater on the Site have been attributed to the storage of elemental sulfur on the ground in the northeastern corner of the current FFF property. Low pH water (as low as 1 to 2 standard units [s.u.]) originates from this area of the Site and extends southward toward Olive Street. However, more neutral pH groundwater is present at and south of Olive Street. The available data indicates an approximate background pH value of between 5 and 6 s.u. for the surficial aquifer.

Metal Distribution

As discussed in the RI report, metals that are COCs at the Site include arsenic, cadmium, chromium, and lead. Elevated arsenic groundwater concentrations exhibit a distribution very different from that exhibited by VOCs, SVOCs and chlorinated pesticides. Therefore, the RI report concluded that the arsenic is not entirely site-related. Regardless, arsenic will be addressed in the groundwater remedial action.

In addition, various other "industrial" metals (cadmium, chromium, copper, lead, nickel, antimony, vanadium, and zinc) were detected at concentrations exceeding MCLs/GCTLs in the surficial aquifer underneath the Landia and FFF properties. The isolated occurrences of copper, nickel, antimony, vanadium, and zinc that exceeded the MCLs are considered non site-related. These metals are present in areas that correspond to the area of groundwater with depressed pH as well as isolated locations across the Site and appear to be attributed to suspended or colloidal solids. A separate plume area for metals was also detected on the western side of the FFF property (near the Tifton property). This plume contains varying concentrations above the MCLs/GCTLs for some of the aforementioned metals. Apparent exceedances of thallium in isolated direct push water samples (DPWS) are considered as non site-related impacts. Similarly, the isolated exceedances for metals in groundwater in areas southeast, south, west, and southwest of the Site are also considered as non site-related impacts. Aluminum, iron and manganese were also detected in groundwater but were considered non site-related.

5.3.3 Sediment Impacts

Sampling conducted in 2006 indicated that the sediment in the Wayman Street Ditch is below FDEP SCTLs for pesticides and metals and does not require remediation to protect human health. The 2006 analytical results were consistent with 2001 sediment data confirming the effectiveness of the prior removal actions and demonstrating the Site no longer contributes to COC impacts above the cleanup goals shown in Table 5 in sediment in the ditch.

Post-RA confirmation samples and samples from unexcavated areas of the Wayman Street Ditch indicate that the north-south reach contains chlorinated pesticides above certain ecological screening values. The ditch is seasonally wet and dry, and it functions primarily as storm water drainage conveyance, rather than a true perennial surface water body with ecological habitat. Sediment samples collected during the RI from the Highland Street Pond, a sediment trap for the drainage network containing the Wayman Street ditch, indicate that the sediments in the Highland Street Pond are not impacted by the Site.

5.3.4 Surface Water Impacts

The Wayman Street Ditch receives surface water runoff from the Site and surrounding industrial and residential properties and traverses the residential area south of the Site. Surface water in Wayman Street Ditch was historically impacted by pesticides, mainly attributed to runoff from the Site and possibly from fluctuation of groundwater levels. These impacts were not observed in Highland Street Pond, downstream of the Site.

After the removal actions which addressed in part, sediments in the ditch, two surface water samples were collected in September 2001 from the concrete-lined portion of Wayman Street Ditch. An estimated value of alpha-BHC was reported for the grab sample that exceeded the Florida Freshwater Surface Water Criteria. However, the composite sample collected over a three hour period did not exceed the Florida Criteria.

6.0 Current and Potential Future Land and Resource Use

6.1 Current and Anticipated Future Land Use

The current land use of the Landia Chemical Company and former Florida Favorite Fertilizer (FFF) properties is industrial. The current land use of the properties immediately surrounding these properties is a mixture of industrial and commercial. The Site is bound to the north by an active railroad corridor and to the south by Olive Street (Figure 2). West of the Site are the Tifton and the Arapahoe Triangle properties (industrial) and immediately east of the Site is a commercial/light industrial property (Pak Teki and Consolidated Diesel) which fronts Olive Street or the first intersecting side street. The area immediately south of Olive Street is a mix of commercial and industrial properties and just south of these mixed properties is a residential area. Land immediately south of the Landia property is owned and occupied by a local religious organization (Church). To the north of the railroad right of way are several commercial/light industrial properties that front George Jenkins Boulevard. These properties include the Lakeland Industrial Park, Southern Milling & Lumber Company, Lineberger Fuel Company, and the YMCA Golf Course property.

Restrictive covenants will be placed on the Landia and former FFF property deeds to limit the future use of the two properties to industrial. The reasonably anticipated future land use of the properties to the east, west and north of the Site is expected to remain commercial and/or industrial. This is primarily due to the location (easy access to rail and U.S. Interstate 4), the increasing value of industrial and commercial properties, and the overall growth of the Central Florida area. The reasonably anticipated future land use of the properties along George Jenkins Boulevard and Olive Street is expected to remain commercial primarily due to the same factors. The reasonably anticipated future land use of the residential area is expected to remain residential. It has been an established neighborhood for many years and it is affordable and located very near downtown Lakeland.

6.2 Current and Anticipated Future Resource Use

Even though the groundwater beneath the Site and the surrounding area is classed as a potential drinking water aquifer by the State of Florida, it is not currently being used as a drinking water supply. The drinking water supply for the Site and the surrounding area is provided by the City of Lakeland and is drawn from deep Floridan Aquifer wells, with the nearest public well field over one mile to the northeast of the Site. Three private irrigation wells were identified during the RI. However, it was confirmed during the RI that these wells were inactive.

Access to impacted groundwater on and surrounding the Site is restricted. In 1999, the FDOH issued a Contaminated Groundwater Advisory for the residential area south of the Site. This advisory requested that permits for new wells be restricted, assisting in preventing the public from accessing groundwater impacted with COCs above cleanup goals shown in Table 5 on or surrounding the Site until cleanup standards are reached. In the future, after the cleanup goals are attained, the aquifer could be used as a drinking water supply if needed and appropriate.

Current surface water uses related to the Landia property consist of a small water body on the property and storm water runoff from the Landia property into the Wayman Street Ditch. The water body on the property is an abandoned, flooded loading ramp which is recharged with groundwater. This water body will not be present in the future. It will be filled with soil during the remedial action to prevent potential exposure to contaminated groundwater. An approximately 4-6 feet long Florida alligator currently lives in the water body and will be relocated prior to the water body being filled with soil.

7.0 Summary of Site Risks

The purpose of the baseline risk assessment is to estimate what risks the Site poses if no action were taken. It provides the basis for taking action and identifies the contaminants and exposure pathways that need to be addressed by the remedial action. This section of the ROD summarizes the results of the baseline risk assessment and the process used for selection of cleanup goals found in Table 5 for the Chemicals of Concern (COCs) at the Landia Chemical Company Site.

Under the NCP, EPA's goal is to reduce the excess lifetime cancer risk to the range of 1×10^{-4} to 1×10^{-6} for the expected future land use at the Site. However, the passage of Florida Statute Chapter 376 in 2005, required cleanups in the State of Florida to reduce the excess lifetime cancer risk to 1×10^{-6} and a hazard index of 1 or less for noncarcinogens. This occurred after the Human Health Risk Assessment (HHRA) was conducted and approved for this Site. Therefore, the COCs for soil and groundwater were further refined in the Feasibility Study (FS) to establish cleanup goals which would attain the 1×10^{-6} risk requirement for carcinogens and a hazard index of 1 or less for noncarcinogens, and the calculated leachability numbers described in Section 7.1.5.

In addition to refining the soil COCs to meet the 1×10^{-6} risk requirement and hazard index of 1 or less, the FS also further evaluated the soil COCs on the industrial properties to ensure that soil contaminants would not be present at levels on site which would leach into the groundwater above groundwater COCs (leachability numbers). As a result the final soil cleanup goals for the industrial properties (Landia, and former FFF properties) were selected to meet the lower of the 1×10^{-6} carcinogenic risk requirement and a hazard index of 1 or less for noncarcinogens based on industrial direct exposure and the leachability number. Soil cleanup goals for the residential areas were selected based solely on attaining the 1×10^{-6} cancer risk requirement and a hazard index of 1 or less for noncarcinogens based on residential, direct contact exposure. Where Florida Soil Cleanup Target Levels (SCTLs) existed and were health based, EPA opted to select these criteria as COCs, if the Florida target levels were more protective.

Contaminant concentrations in the groundwater must ultimately be reduced to meet drinking water standards because the impacted groundwater aquifer is a potential drinking water source and a resource of the State of Florida. Therefore, EPA determined that rather than evaluate groundwater contaminants in the HHRA, it would be more appropriate to select COCs and cleanup goals based on a comparison of federal and state drinking water standards. The maximum groundwater contaminant concentrations were compared to the State of Florida and Federal promulgated drinking water standards (Maximum Concentration Levels or MCLs). Where MCLs were not available, Florida Groundwater Cleanup Target Levels (GCTLs) were used where they were health based. Groundwater cleanup goals were selected based on attaining either the most stringent MCL or the GCTL if no MCL were promulgated.

The following sections describe this process beginning with the development of the HHRA, the refinement of COCs to meet the 1×10^{-6} cancer and noncancer hazard index of 1 or less requirements, the development of leachability numbers, the evaluation of ecological risks through the Screening Level Ecological Risk Assessment (SLERA) and the selection of cleanup goals.

7.1 Summary of Human Health Risk Assessment

Between 2002 and 2003, a Human Health Risk Assessment (HHRA) was conducted to evaluate potential risks to human health associated with chemicals detected in soil, surface water, and sediment samples collected from the Site and neighboring off-site locations. For the evaluation of soil impacts, the study area was divided into industrial areas; generally the area north of Olive Street up to and including the railroad tracks (Figure 2) and residential areas for the remaining areas south of Olive Street.

The HHRA found that the risk from probable exposure to surface soil in the industrial area by an on-site worker exceeds 1×10^{-4} , thereby triggering further action under Superfund. The HHRA found that the risk from probable exposures to surface soil, sediment and surface water in the residential area does not exceed 1×10^{-4} but does exceed 1×10^{-6} in some areas.

7.1.1 Chemicals of Concern

Soil data were divided into industrial and residential areas. Based on past and current land use, the industrial areas were further divided into the following separate industrial areas: East of Landia, Landia Chemical, FFF, Tifton and Arapahoe Triangle. EPA determined that it is likely that different worker receptors could be exposed to each of these properties. The residential area is located south of the industrial area. Surface soil samples were collected from all residential properties abutting the Wayman Street ditch between the Site and Plateau and randomly throughout the remaining neighborhood between Olive Street and the Wayman Street ditch. Surface soil in the residential area was evaluated on a sample-by-sample basis, since each sample generally represented an individual house. It is likely that residential receptors could be exposed to soil only in their backyards. Therefore, each sample was evaluated separately and was not grouped into exposure areas. Subsurface soil in the residential area was considered to be one exposure area. EPA determined that a future construction worker receptor has equal likelihood of contacting subsurface soil in the entire residential area.

Chemicals in surface and subsurface soil in the five industrial exposure areas were compared to background levels and industrial screening criteria. Industrial soil screening criteria were defined as the lower of the U.S. EPA Region 9 Preliminary Remediation Goals (PRGs) for industrial soil using a hazard index of 0.1 for noncarcinogens, and Florida SCTLs found in F.A.C., Chapter 62-777 for industrial soil. Chemicals in surface and subsurface soil in the residential area were compared to residential soil screening criteria, which were defined as the lower of the U.S. EPA Region 9 PRGs for residential soil using a hazard index of 0.1 for noncarcinogens and the Florida SCTLs for residential soil. Most of the residential surface soil samples had only one or two COPCs.

Chemicals in groundwater were compared to groundwater screening criteria. Groundwater screening criteria were defined as the lower of the Florida or Federal MCL. U.S. EPA Region 9 PRGs for tap water using a hazard index of 0.1 for noncarcinogens, were used for chemicals where neither Florida nor Federal MCLs were available.

Surface water and sediment samples were collected from the Wayman Street ditch and the Highland Street Pond. It was assumed that a residential child receptor could have equal access to all of the sample locations, therefore the surface water and sediment samples were grouped into one exposure area. Chemicals in surface water were compared to surface water screening criteria. Surface water screening criteria were defined as the lower of the FDEP Surface Water Cleanup Target Levels (SWCTL) and the National Recommended Ambient Water Quality Criteria (AWQC) for consumption of water and organisms. The U.S. EPA Region 9 PRGs for

tap water were used if no AWQC was available. Chemicals in sediment were compared to residential soil screening criteria defined above.

As discussed above, the COPCs in the HHRA were later refined in the FS to meet the 1×10^{-6} risk requirement for carcinogens, a hazard index of 1 or less for noncarcinogens, and/or to meet leachability numbers. Table 1 presents the minimum and maximum detected concentrations, frequency of detection, and maximum exposure point concentrations for the final soil COCs selected for the residential area after refinement in the FS. Table 2 presents this information for the soil COCs selected for the industrial areas based solely on direct contact exposure.

7.1.2 Exposure Assessment

The HHRA evaluated potential exposure through a number of exposure scenarios, including current and potential future exposure scenarios for industrial and residential areas. The industrial areas were divided into east of Landia, Landia Chemical, FFF, Tifton, and Arapahoe Triangle. The receptors evaluated for the industrial areas include an on-site worker, construction worker, and trespasser. The residential area is located south of the industrial area. It was assumed that adult and child residents could be exposed to surface soil in the residential area on a house-by-house basis. It was also assumed that the child resident could be exposed to surface water and sediment in the Wayman Street Ditch and the Highland Street Pond. It was assumed that a construction worker could be exposed to surface and subsurface soil in the residential area. The conceptual site model, Figure 3, presents the potential exposure pathways.

For each route of exposure, a reasonable maximum exposure (RME) scenario was developed based on EPA's Risk Assessment Guidance for Superfund (RAGS) and EPA Region 4 Human Health Risk Assessment Bulletins – Supplement to RAGS. The specific exposure factors used for calculating risks at the Site are provided in the HHRA.

Incidental ingestion and dermal contact with surface soil and inhalation of fugitive dust in outdoor air at the five industrial areas was evaluated for an on-site worker and a trespasser. Incidental ingestion and dermal contact with subsurface soil and inhalation of fugitive dust in outdoor air at the five industrial areas and the residential area was evaluated for a construction worker using an RME.

Incidental ingestion and dermal contact with surface soil, inhalation of fugitive dust in outdoor air, and incidental ingestion and dermal contact with surface water and sediment were evaluated using an RME for an adult and child resident. Incidental ingestion and dermal contact with subsurface soil and inhalation of fugitive dust in outdoor air was evaluated for a construction worker.

No exposure pathways were identified for groundwater under current conditions because groundwater in the area is not being used as potable water. A Contaminated Groundwater Advisory was issued by the FDOH in 1999 for the residential area south of the Site. This advisory requested that permits be restricted for new wells, assisting in preventing the public from accessing groundwater impacted by site activity. In the 2000 Public Health Assessment, FDOH also recommended that Site access be restricted to prevent exposure to on-Site surface soils.

Table 1
Summary of Chemicals of Concern and
Medium-Specific Exposure Point Concentrations (Residential)

Scenario Timeframe: Current and Future

Medium: Soil

Exposure Medium: Soil

Exposure Point	Chemical of Concern	Concentration Detected		Units	Frequency of Detection (detection/ # samples)	Exposure Point Concentration	Exposure Point Concentration Units	Statistical Measure
		Min	Max					
Offsite Soil Residential Area Direct Contact	4,4-DDD	0.0007	13	Ppm	14/109	13	ppm	Max
	4,4-DDT	0.0007	30	Ppm	69/109	30	ppm	Max
	Aldrin	0.0006	0.12	Ppm	4/109	0.12	ppm	Max
	alpha-BHC	0.0003	0.29	ppm	5/109	0.29	ppm	Max
	alpha-Chlordane	0.004	3.7	ppm	12/109	3.7	ppm	Max
	Arsenic	0.52	3.0	ppm	15/109	3.0	ppm	Max
	Chlordane (technical)	0.12	8.2	ppm	10/109	8.2	ppm	Max
	Dieldrin	0.0004	0.22	ppm	52/109	0.22	ppm	Max
	Heptachlor	0.0002	0.29	ppm	17/109	0.29	ppm	Max
	Heptachlor epoxide	0.0008	0.28	ppm	25/109	0.28	ppm	Max
	Lead	2.7	120	ppm	107/109			
	Toxaphene	0.078	11	ppm	3/109	11	ppm	Max

ppm: parts per million

Table 2
Summary of Chemicals of Concern and
Medium-Specific Exposure Point Concentrations (Industrial Area)

Scenario Timeframe: Current and Future

Medium: Soil

Exposure Medium: Soil

Exposure Point	Chemical of Concern	Concentration Detected		Units (ppm = parts per million)	Frequency of Detection (detection/# samples)	Exposure Point Concentration	Exposure Point Concentration Units	Statistical Measure
		Min	Max					
Onsite Soil Industrial Area Direct Contact	4,4-DDE	0.003	20	ppm	107/142	20	ppm	Max
	Aldrin	0.00005	370	ppm	20/106	370	ppm	Max
	alpha-Chlordane	0.0007	77	ppm	95/103	77	ppm	Max
	Arsenic	0.41	189	ppm	57/140	189	ppm	Max
	Chlordane (technical)	0.023	100	ppm	35/37	100	ppm	Max
	Dioxin (TEQ)	(1)						
	Heptachlor	0.0008	31	ppm	44/120	31	ppm	Max
	Heptachlor epoxide	0.002	0.7	ppm	25/106	0.7	ppm	Max
	Hexachlorobenzene	(2)						
	Lead	4.6	1020	ppm	125/127			
	Toxaphene	0.12	1500	ppm	30/124	1500	ppm	Max

(1) Dioxin was sampled and evaluated separately from the other soil contaminants in the industrial area. The primary extent of dioxin contamination was found to be on the FFF property. The cleanup goal was established to be consistent with the 1×10^{-6} risk requirement.

(2) Hexachlorobenzene was selected as a COC during refinement.

7.1.3 Toxicity Assessment

The purpose of the toxicity assessment is to identify the types of adverse health effects a chemical may potentially cause, and to define the relationship between the dose of a chemical and the likelihood or magnitude of an adverse effect (response) (U.S. EPA, 1989a). Adverse effects are classified by USEPA as potentially carcinogenic or non-carcinogenic (i.e., potential affects other than cancer). Dose-response relationships are defined by USEPA for oral exposure and for exposure by inhalation. Oral toxicity values are also used to assess dermal exposures, with appropriate adjustments, because USEPA has not yet developed values for this route of exposure. Combining the results of the toxicity assessment with information on the magnitude of potential human exposure provides an estimate of potential risk.

Sources of the published toxicity values in the risk assessment include U.S. EPA's Integrated Risk Information System (IRIS) (U.S. EPA, 2002a), the Health Effects Assessment Summary Tables (HEAST) (U.S. EPA, 1997b), and the USEPA National Center for Environmental Assessment (NCEA) in Cincinnati, Ohio.

7.1.4 Risk Characterization

For carcinogens, risks are generally expressed as the incremental probability of an individual's developing cancer over a lifetime as a result of exposure to the carcinogen. Excess lifetime cancer risk is calculated from the following equation:

$$\text{Risk} = \text{CDI} \times \text{SF}$$

where: risk = a unitless probability (e.g., 2×10^{-5}) of an individual developing cancer
CDI = chronic daily intake averaged over 70 years (mg/kg-day)
SF = slope factor, expressed as (mg/kg-day)⁻¹.

These risks are probabilities that usually are expressed in scientific notation (e.g., 1×10^{-6}). An excess lifetime cancer risk of 1×10^{-6} indicates that an individual experiencing the reasonable maximum exposure estimate has a 1 in 1,000,000 chance of developing cancer as a result of site-related exposure. This is referred to as an "excess lifetime cancer risk" because it would be in addition to the risks of cancer that individuals face from other causes such as smoking or exposure to too much sun. The chance of an individual developing cancer from all other causes has been estimated to be as high as one in three. EPA's generally acceptable risk range for site-related exposures is 1×10^{-4} to 1×10^{-6} . As discussed previously, the COCs for soil and groundwater at this site were further refined in the Feasibility Study (FS) to establish cleanup goals which would attain the State of Florida's 1×10^{-6} cancer risk for carcinogens and a hazard index of 1 or less for noncarcinogens.

The potential for non-carcinogenic effects is evaluated by comparing an exposure level over a specified time period (e.g., life-time) with a reference dose (RfD) derived for a similar exposure period. An RfD represents a level that an individual may be exposed to that is not expected to cause any deleterious effect. The ratio of exposure to toxicity is called a hazard quotient (HQ). An HQ < 1 indicates that a receptor's dose of a single contaminant is less than the RfD, and that toxic non-carcinogenic effects from that chemical are unlikely. The Hazard Index (HI) is generated by adding the HQs for all COPCs that affect the same target organ (e.g., liver) or that act through the same mechanism of action within a medium or across all media to which a given individual may reasonably be exposed. An HI < 1 indicates that, based on the sum of all HQ's

from different contaminants and exposure routes, toxic non-carcinogenic effects from all contaminants are unlikely. An HI>1 indicates that site-related exposures may present a risk to human health.

The HQ is calculated as follows:

$$\text{Non-cancer HQ} = \text{CDI/RfD}$$

where: CDI = chronic daily intake
RfD = reference dose.

CDI and RfD are expressed in the same units and represent the same exposure period (i.e., chronic, subchronic, or short-term).

The target cancer risk and hazard index (HI) levels used for the identification of chemicals of concern (COCs) are based on EPA (EPA, 1991) and EPA Region 4 guidance (EPA, 2000a). The results of the risk characterization show that chemicals detected in the residential area in surface soil, subsurface soil, sediment and surface water do not pose unacceptable risks. The predicted cancer risk levels are all below 1×10^{-4} , and the non-carcinogenic HIs are all below 1.

The predicted carcinogenic risk levels for surface soil exceed 1×10^{-4} at FFF and Landia Chemical. The non-carcinogenic HIs also exceed 1 at Landia Chemical. These results indicate that, based on the exposure point concentrations and exposure assumptions used in the HHRA, further action is warranted at these industrial areas. The majority of the predicted risk levels in surface soil are due to the BHCs, dieldrin and toxaphene at FFF and alpha-BHC and DDT at Landia Chemical. The majority of the predicted risk levels in subsurface soil are due to DDT and dieldrin at FFF and toxaphene and chlordane at Landia Chemical. In the HHRA, risk assessment cleanup goals were calculated for chemicals with carcinogenic risk levels above 1×10^{-6} or HI above 1.

7.1.5 Refinement of COCs

After the HHRA was approved in 2003, Florida adopted Florida Statute Chapter 376 in 2005 which required cleanups in the State of Florida to reduce the excess lifetime cancer risk to 1×10^{-6} and a noncarcinogenic hazard index of 1 or less. In the Feasibility Study, COCs were refined to ensure that all COCs which exceeded the 1×10^{-6} cancer risk and a hazard index of 1 or less criterias were retained as COCs. Soil COCs were also screened to determine if they exceeded the leaching default criteria and if so, were further evaluated.

For constituents in soil that exceeded the leaching default criteria only, the COC was retained if present in groundwater above the default GCTL. The leaching pathway is relevant only if groundwater concentrations beneath or downgradient of an area of contaminated soil location exceed the GCTL for the contaminant in the soil. FDEP and EPA guidance acknowledges the leaching pathway is incomplete if a COC is not detected in groundwater above the GCTL after having sufficient time to leach from soil to groundwater.

The synthetic precipitation leaching procedure (SPLP) test results and the FDEP leaching-based SCTLs were compared to groundwater concentrations in the nearest downgradient well for the pesticides of interest at the Site. Out of the 180 samples that were compared, in only two cases (1.1%) were the leachate concentrations below the GCTLs and the groundwater concentration in

the downgradient well was above the GCTLs. In 87% of the comparisons, the downgradient groundwater concentrations were below the leachate concentration. This showed that the SPLP tests were appropriate to evaluate leaching pathways and the FDEP leaching-based SCTLs were conservatively protective of the leaching pathway. In some instances, the FDEP leaching-based SCTLs may have been overly protective of leaching pathways where soil concentrations exceed the leaching-based SCTLs but the downgradient groundwater concentrations were below the GCTLs.

For constituents in soil that were retained for leaching after the above screening steps, alternate site specific leaching SCTLs were developed in accordance with the Equation for the Determination of SCTLs based on Leachability included as Figure 8 in the Technical Report: Development of Soil Cleanup Target Levels (SCTLs) for Chapter 62-777 F.A.C. (FDEP, 2005).

The site-specific parameters used in the development of the site-specific leaching-based SCTLs were the soil-water partition (K_d) data calculated from SPLP data and a site-specific, COC specific dilution factor (DF). All other parameters used in the calculations were FDEP default values.

The K_d calculated for the three methods was compared to the K_d provided in Table 4 (Chemical Specific Values) of the Technical Report: Development of Soil Target Cleanup Levels (SCTLs) for Chapter 62-777, F.A.C. Of the pesticides analyzed, the FDEP default value for K_d , which is used to develop the leaching-based SCTLs, is lower than the site-specific K_d for all three calculation methods for alpha-BHC, beta-BHC, delta-BHC, gamma-BHC (lindane), chlordane (technical), and dieldrin. For 4,4'-DDE, 4,4'-DDT, and aldrin, the FDEP K_d value falls within the range of site-specific values. A higher K_d value means a constituent is more likely to sorb to soil or, that is, less likely to leach to groundwater. Therefore, the SPLP data indicates that for alpha-BHC, beta-BHC, delta-BHC, gamma-BHC (lindane), chlordane (technical), and dieldrin, the default leaching-based SCTL is overly conservative. The other three constituents have site-specific K_d values that are near the FDEP default K_d values.

The DF was calculated using the equation presented in EPA's Soil Screening Guidance: User's Guide (1996). Site-specific values for hydraulic conductivity, hydraulic gradient, mixing zone depth, infiltration rate, and source length were used to calculate the DF for each COC.

Overall, the site-specific leaching-based SCTLs can change significantly based on the DF; the higher the DF, the higher the SCTL and vice versa. FDEP's default DF in the development of leach based SCTLs is 20; however, the site-specific DF varied between 7 and 10. A major assumption in the determination of the DF is the length of the source term parallel to groundwater flow. A longer source length results in a lower DF, whereas a shorter source term length results in a higher DF.

The cleanup goals for soil and groundwater were selected after evaluating potential risks from COPCs in the HHRA, further refining them to meet Florida's requirement that cleanups meet a 1×10^{-6} cancer risk and noncancer hazard index of 1 or less, and evaluating soil contaminants to ensure protection of groundwater. These cleanup goals along with the basis for their selection are found in Section 12.2.4, Table 5.

7.1.6 Uncertainty

The large number of assumptions made in the risk characterization introduces uncertainty in the results. While this approach could potentially underestimate potential risk, the use of numerous, conservative (i.e., protective of human health) assumptions, in the risk characterization, typically overestimates potential risk. Any one person's potential exposure and subsequent risk are influenced by all the parameters utilized in the HHRA and will vary on a case-by-case basis. Despite inevitable uncertainties associated with the steps used to derive potential risks, the use of numerous health-protective assumptions will most likely lead to a very large overestimate of potential risks from the Site. Moreover, when evaluating risk assessment results, it is important to put the risks into perspective. For example, the background rate of cancer in the U.S. is approximately 2,500 for a population of 10,000 people (Landis, et al., 1998). The results of the risk assessment must be carefully interpreted considering the uncertainty and conservatism associated with the analysis, especially where site management decisions are made.

Uncertainties associated with the HHRA include uncertainties related to data evaluation, exposure pathways and parameters, toxicity, and risk characterization, as discussed in the following paragraphs.

Data Evaluation

The purpose of data evaluation is to determine which constituents, if any, are present at the Site at concentrations requiring further investigation. The screening process used to select COPCs to evaluate in the BHHRA was intended to include all chemicals with concentrations high enough to be of concern for the protection of public health.

Uncertainty with respect to data evaluation can arise from many sources, such as the quality and quantity of the data used to characterize the Site, the process used to select data to use in the risk assessment, and the statistical treatment of data.

Exposure Pathways and Parameters

The exposure assumptions directly influence the calculated doses (daily intakes), and ultimately the risk calculations. For the most part, site-specific data were not available for this BHHRA; therefore, conservative default exposure assumptions were used in calculating exposure doses such as the selection of exposure routes and exposure factors (e.g., contact rate). In most cases, this uncertainty may overestimate the most probable realistic exposures and, therefore, may overestimate risk. This is appropriate when performing risk assessments of this type so that the risk managers can be reasonably assured that the public risks may not be underestimated, and so that risk assessments for different locations and scenarios can be compared.

In order to estimate a receptor's potential exposure at a site, it is necessary to determine the geographical location where the receptor is assumed to be exposed. Once the area of interest has been defined, the appropriate data can be selected and the exposure point concentration can be calculated. The primary source of uncertainty associated with estimating exposure point concentrations involves the statistical methods used to estimate these concentrations and the assumptions inherent in these statistical methods. Generally, an upper bound estimate of the mean concentration is used to represent the exposure point concentration instead of the measured mean concentration. This is done to account for the possibility that the true mean is higher than the measured mean because unsampled areas of the Site may have higher constituent concentrations.

Generally, in order to present a range of possible exposure estimates, a central tendency risk describer is calculated in addition to the reasonable maximum exposure risk, in accordance with Region 4 policy. The reasonable maximum exposure approach characterizes risk at the upper end of the risk distribution, while the central tendency approach characterizes either the arithmetic mean risk or the median risk. The inclusion of both reasonable maximum exposure and central tendency risk describers provides perspective for the risk manager. However, the National Contingency Plan (NCP) Section 300.430(d) states, "The reasonable maximum exposure estimates for future uses of the site will provide the basis for the development of protective exposure levels."

Toxicity Assessment

For a risk to exist, both significant exposure to the chemicals of potential concern and toxicity at these predicted exposure levels must exist. The toxicological uncertainties primarily relate to the methodology by which carcinogenic and noncarcinogenic criteria (i.e., CSFs and reference doses) are developed. In general, the methodology currently used to develop CSFs and reference doses is very conservative, and likely results in overestimation of human toxicity.

Risk Characterization

Ideally, areas of exposure should be defined based on actual exposures or known behaviors of receptors at the Site. Often, however, as in the case of this risk assessment, this information is unavailable. Lacking absolute knowledge about the behaviors of receptors at or near the Site, it was necessary to make some assumptions. This risk assessment made assumptions about exposure units (or areas) based on contaminant distribution and likely areas of exposure based on Site features. Such assumptions will add to the uncertainty in the HHRA.

Each complete exposure pathway concerns more than one contaminant. Uncertainties associated with summing risks or hazard quotients for multiple substances are of concern in the risk characterization step. The assumption ignores the possibility of synergistic or antagonistic activities in the metabolism of the contaminants. This could result in over- or under-estimation of risk.

The potential risks developed for the Site were directly related to COPCs detected in the environmental media at this Site. No attempt was made to differentiate between the risk contributions from other sites and those being contributed from this Site.

All of the uncertainties discussed above ultimately effect the risk estimate. Most of the uncertainties identified will result in the potential for overestimation of risk (e.g., the combination of several upper-bound assumptions for some exposure scenarios).

As discussed in the previous section, the COPCs from the HHRA were refined in the FS and the final cleanup goals were established based on achieving a 1×10^{-6} risk for carcinogens, a hazard index of 1 or less for noncarcinogens, or for protection of groundwater (leachability). Where Florida Soil Cleanup Target Levels (SCTLs) and Groundwater Cleanup Target levels existed and were health based, EPA opted to select these criteria as COCs, if the Florida target levels were more protective. For those two groundwater contaminants (2,4-dichlorophenol and xylene) for which the Florida GCTL were not entirely health based, EPA developed health based cleanup goals to achieve 1×10^{-6} risk. Therefore, the fact that cleanup goals were selected based on regulatory requirements rather than from the HHRA makes any uncertainty that would either overestimate or underestimate the risk in the HHRA irrelevant.

7.2 Summary of Ecological Risk Assessment

7.2.1 Screening Level Ecological Risk Assessment (SLERA)

A SLERA was conducted in 2003 following EPA Region 4 (2001a) draft guidance, and satisfies Steps 1 and 2 of the national EPA (1998) Guidance for Superfund. Potential ecological risks due to exposure to three environmental media (surface soil, sediment, and surface water) were evaluated in four exposure areas. Surface soil was evaluated in the Industrial Area and the Church Property/Field Area. Sediment and surface water were evaluated in the Wayman Street ditch and Highland Street Ponds. Maximum detected concentrations or maximum detection limits of each constituent measured in each exposure area were compared to EPA Region 4 screening values. The list of screening level contaminants retained in the SLERA were evaluated to help refine the COPCs and to determine the need for future ecological risk evaluation at this industrial facility. This refinement is the basis for Step 3 (Problem Formulation) of the EPA Superfund guidance.

Based on the screening results and development of the Problem Formulation, no additional ecological risk activities at the Site were recommended in the SLERA. This conclusion was based on the following lines of evidence developed in the SLERA and Problem Formulation:

- Following the refinement of COPCs, pesticides in the Industrial Area surface soil are the primary constituents of potential concern to ecological receptors. Given the relatively limited ecological habitat in this area, additional ecological risk assessment activities are not warranted. Should the Industrial Area be subject to a soil removal or remedial action due to human health concerns; it is highly likely that any potential ecological exposure pathways will also be eliminated.
- Some constituents in surface soil samples from the Church Property/Field Area were detected at concentrations that exceeded ecological screening values. The maximum detected COPC concentration used was measured in a sample collected adjacent to Wayman Street, and may be related to urban contamination from Wayman Street or the other roads adjacent to the Church Property/Field Area.
- With the exception of inorganic constituents, all detected constituents in surface water had hazard quotients (HQs; defined as the exposure point concentration divided by the screening value) < 1 . The surface water constituents with $HQ > 1$ are inorganic constituents, which were measured as total recoverable, but compared to dissolved phase benchmarks. If dissolved inorganic constituents data were available, these constituents may have $HQ < 1$. Since these inorganic constituents, with the exception of lead, have not been directly linked to the Site, the inorganic constituents detected in surface water are probably present due to stormwater runoff from the surrounding urban area.
- Five COPCs were identified in the Wayman Street Ditch sediment. Three of the COPCs are constituent groups. Dieldrin and two of the three constituent group COPCs include detected constituents. Toxaphene and total PAH were not detected in the sediments. Maximum detected concentrations of dieldrin and total DDx were lower than acute level screening values.

7.2.2 Uncertainty

The SLERA was based on data that have been collected for a number of years, and was developed using the most recent EPA guidance for preparing ecological risk assessments. However, as methods are improved, differences in the best available technology for sample

collection, storage, clean-up, and analysis may lead to variability, as well as uncertainty, with the data. Because some of the data for this risk assessment are several years old, the conditions that are represented by the older data may not be the same as current conditions, particularly for constituents that are biodegradable or photodegradable. Some of the historical data were collected using focused environmental sampling techniques, which were intended to characterize constituent concentrations and delineate the boundaries of the areas of highest contamination. Ecological receptors integrate exposure over time and space. Focused sampling may therefore have contributed to an overestimate or underestimate of exposure point concentrations. Finally, data quality was not adequate to fully evaluate the potential risks to ecological receptors because many detection limits exceeded Region 4 screening values. These constituents with detection limits above screening values were not detected, but were retained as SLCOPCs in the SLERA. This may contribute to an overestimate of exposure point concentrations for these constituents.

Another source of uncertainty is the SLCOPCs for which there was no screening benchmark. Further investigation and evaluation would be required to establish whether these SLCOPCs pose a potential risk. EPA extrapolated the potential for population, community, or ecosystem effects for these SLCOPCs based on the examination of the potential effects of these SLCOPCs on one or more representative species which may not be present at the Site. The underlying assumption for this extrapolation is that potential effects on one representative species are consistent with the effects on similar species and representative of the potential for effects on the particular ecosystem being investigated. Thus, for the aquatic risk assessment, the Region 4 toxicity values for sensitive freshwater species were chosen to represent the potential for adverse chemical effects on the aquatic ecosystem. The selection of these species as representative indicators of the ecosystems presented in this SLERA is a major source of uncertainty for both the aquatic and terrestrial analyses.

It is difficult to predict how an adverse effect on an individual organism might affect the ecosystem as a whole. If adverse effects are predicted for an individual, it does not necessarily mean that the population, community, or ecosystem will be similarly affected. Even if one subset of the ecosystem is impacted in a localized area, such effects may no result in a perceptible impact to the overall ecosystem (e.g., loss of individual fish may not affect resident population).

Consistent with Region 4 guidance for conducting a SLERA, concentrations of constituents in background media were not considered in the selection of SLCOPCs. The ambient concentrations of many constituents are elevated compared to Region 4 screening values. Some constituents may be elevated due to naturally occurring conditions or non-site related activities. In addition, the potential effect of background concentrations of SLCOPCs arising from other sources may affect local populations. Also consistent with Region 4 guidance, the maximum detected concentration (or the maximum SQL for non-detected constituents) was selected as the EPC. Although this conservatively represents a worst-case scenario, it is highly unlikely that organisms or communities of organisms would be exposed to the absolute maximum of any constituent for the duration of their lifetimes. Even relatively sessile organisms, such as terrestrial invertebrates, will move during its lifetime and, given the heterogeneous nature of the concentrations of constituents in surficial media, is not likely be exposed exclusively to any particular concentration of SLCOPCs.

The data collected and used in the SLERA, and Region 4 SLERA guidance, do not consider the potential bioavailability of the SLCOPCs. For instance, the surface water data collected from the Wayman Street Ditch and Highland Street Ponds reflect the total recoverable fraction of the inorganic SLCOPCs. However, USEPA (1995) recognizes that the dissolved fraction of many metals should be used for analysis of data, since this fraction is the bioavailable and therefore

potentially toxic fraction of the metal in surface water. There are also many potential binding phases for inorganic and organic constituents in surface soil, sediment, and surface water that may limit bioavailability. For instance, the USEPA (1993) equilibrium partitioning theory indicates that organic carbon will bind and limit or eliminate the bioavailability of nonpolar organic constituents. The presence of acid-labile sulfide may bind and limit the bioavailability of several heavy metals in sediment. USEPA currently has draft Equilibrium Sediment Guidelines (ESGs) for determining the bioavailable fraction of constituents in sediment in the presence of organic carbon and/or sulfide.

Lastly, in accordance with Region 4 guidance, non-detected constituents with no Region 4 screening values were retained as SLCOPCs. This approach adds considerable uncertainty to the SLERA approach and likely results in an overly conservative evaluation of potential risks to ecological receptors at the Landia Site, since there is no indication that these constituents are present at the Site (i.e., they were non-detected in the multiple rounds of sampling that have occurred at this Site during the past two decades).

8.0 Remedial Action Objectives

Remedial Action Objectives (RAOs) for the Landia Chemical Company site were developed based on a review of the results of the site sampling data, site-specific risk and fate and transport evaluations, and review of ARARs. The passage of Florida Statute Chapter 376 in 2005, established risk management options for contaminated sites and cleanup target levels for impacted media. It established 1×10^{-6} as an ARAR for determining acceptable carcinogenic risk associated with impacted media and a requirement to attain a hazard index of 1 or less for noncarcinogens.

Past operations at the Site resulted in the contamination of surface soil, subsurface soil and groundwater. The primary COCs at the Site include pesticides, nitrates and some metals. As with many Superfund sites, the problems associated with the Landia Chemical Company site are complex. As a result, the Site was divided into two operable units in order to divide the work into manageable pieces. Operable Unit 1 (OU1) addresses the COCs present in soil and Operable Unit 2 (OU2) addresses the COCs present in the groundwater. The following RAOs were developed for this action to address all COCs in OU1 and provide an interim action for the COCs in OU2. The RAOs were developed to protect current and reasonably anticipated future land uses anticipated for the two on-site properties and properties to the east, west, and north of the Site (i.e., commercial and/or industrial uses). The cleanup goals developed to attain these RAO's are found in Section 12.2.4, Table 5.

OPERABLE UNIT 1 (Soil Contamination):

- Prevent direct contact with and/or ingestion of soil containing site-related COCs at concentrations above health-based action levels.
- Prevent or minimize future migration of COCs in soil to groundwater that would result in groundwater concentrations above drinking water standards.

OPERABLE UNIT 2 (Groundwater Contamination):

- Prevent direct contact and/or ingestion of groundwater containing site-related COCs at concentrations above health based drinking water standards.
- Prevent or minimize further migration of the contaminant plume by reducing the concentrations of groundwater contamination in the areas of highest site-related groundwater concentrations above drinking water standards.

9.0 Description of Alternatives

The purpose of this section is to briefly summarize the remedial alternatives that were evaluated in the FS for soil and groundwater at the Site.

9.1 Alternative S1: No Action

The no action alternative was developed as required by the NCP, the regulation implementing the Superfund law. It is used as a baseline for comparing other alternatives. Under this alternative, EPA would take no action to remedy any contaminated soil at the Site. The potential risks associated with the soil contamination would not be minimized by this action.

- Estimated construction costs: \$0
- Estimated O&M costs: \$0
- Total present worth cost: \$0
- Estimated Annual O&M Cost: \$0
- Estimated Present Worth Costs: \$0

9.2 Alternative S2: Excavation with off-site disposal of soils

Alternative S2 consists of the following components:

- Excavation of soil exceeding cleanup goals;
- Transportation and off-site disposal of excavated soils;
- Backfill and grading; and
- Institutional controls

Under alternative S2 approximately 23,900 cubic yards of contaminated soil exceeding cleanup goals (Table 5) would be excavated, loaded, transported and disposed of at an appropriately permitted disposal facility. The estimated areas of the exceedances of remedial goals that would be excavated under alternative S2 are shown in Figure 6. The volume of impacted soil that would be excavated includes impacted soil under paved surfaces and some buildings on the Landia property. Excavated soil would be sampled and analyzed by the Toxicity Characteristic Leaching Procedure (TCLP) to determine if it is a Resource Conservation and Recovery Act (RCRA) characteristic hazardous waste, or by the methodology required by the disposal facility. Based on past response actions at the Site, it is anticipated that the results will show that it is not a hazardous waste. Any excavated soil and sediment with characteristics requiring it to be classified as RCRA hazardous waste will be treated pursuant to RCRA requirements (40 CFR 268) prior to disposal in an offsite Subtitle D landfill.

After excavation and disposal, confirmation samples would be taken to ensure the cleanup goals have been achieved and the excavated areas would then be backfilled and graded appropriately. Backfill material may be amended with lime or limestone to increase the buffering capacity of the soil. The depressed loading ramp on the Landia property would be perforated and backfilled to match the surrounding ground surface to prevent the ramp from collecting water.

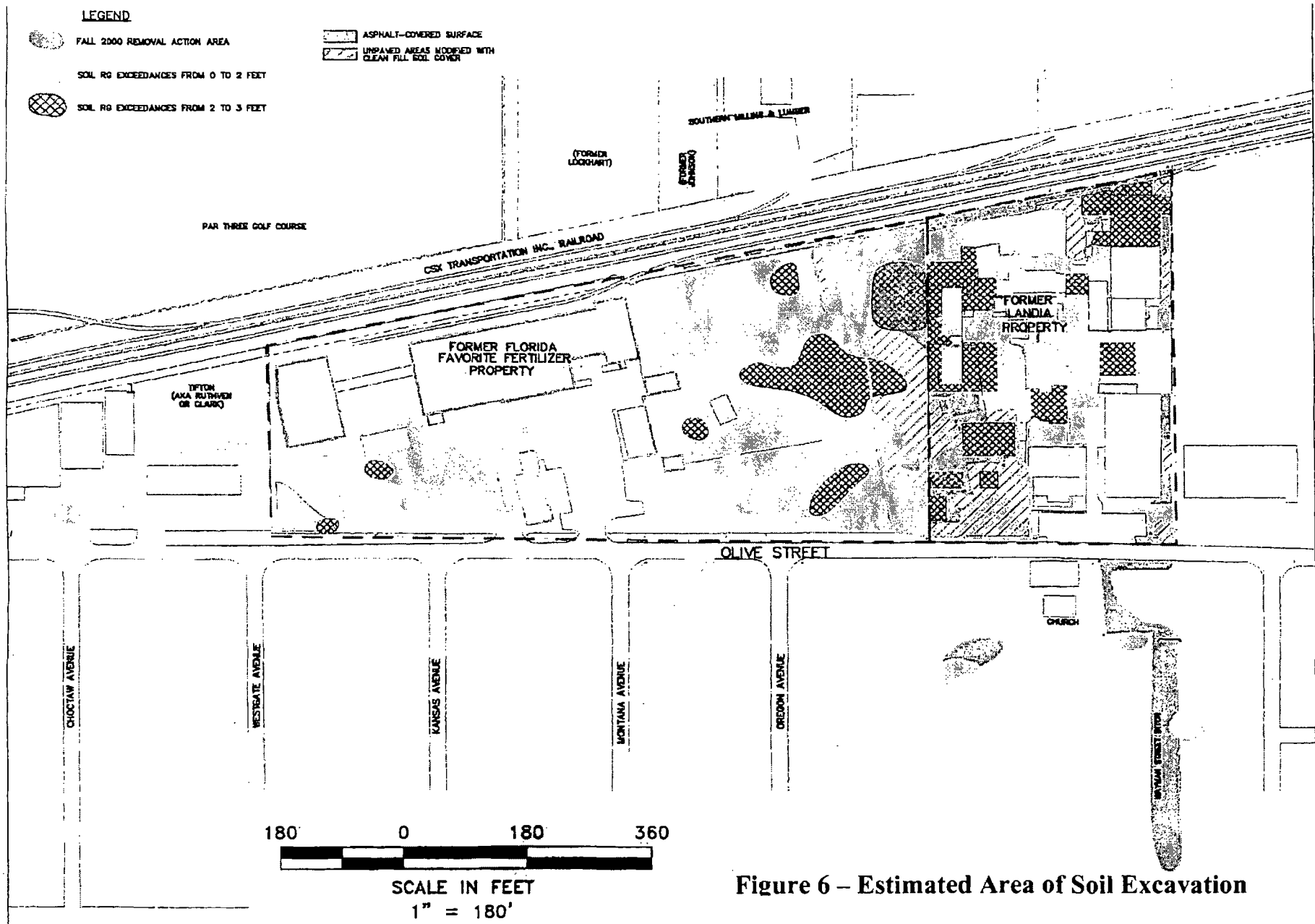

Institutional controls in the form of restrictive covenants would be placed on the Landia and former FFF properties to limit the future use of the properties to industrial and to limit future construction activities to prevent the potential exposure to any contaminated soil remaining under building foundations. Institutional controls would also include any relied upon engineered barriers (e.g. concrete slab, asphalt cap) to be maintained to prevent exposures to impacted soil.

It is anticipated that Alternative S2 would remove the direct exposure risks for commercial and industrial uses and minimize contaminants from migrating into the groundwater.

The costs associated with Alternative S2 are:

- Estimated construction costs: \$4,021,400
- Estimated O&M costs: \$0
- Total present worth cost: \$4,021,400 (using a discount rate of 7%)
- Estimated Construction Timeframe: 6 months
- Estimated Time to Achieve RAOs: 6 months

9.3 Alternative S3: Excavation with partial off-site disposal of soils and partial on-site consolidation and capping

Alternative S3 consists of the following components:

- Excavation of all soil exceeding cleanup goals noted in Table 5;
- Transportation and off-site disposal of soil exceeding site-specific leachability based cleanup levels;
- On-site consolidation of soils below site-specific leachability based cleanup levels;
- Engineered capping of consolidated areas; and
- Institutional controls.

Under alternative S3 approximately 23,900 cubic yards of contaminated soil exceeding cleanup goals noted in Table 5 would be excavated as in alternative S2. The volume of impacted soil that would be excavated includes impacted soil under paved surfaces and some buildings on the Landia property. The estimated areas of the exceedances of remedial goals that would be excavated under alternative S2 are shown in Figure 6.

An estimated 19,690 cubic yards of soil which exceeded leachability cleanup goals noted in Table 5 would be excavated, loaded, transported and disposed of at an appropriately permitted disposal facility. This soil would be sampled and analyzed by the Toxicity Characteristic Leaching Procedure (TCLP) to determine if it is a Resource Conservation and Recovery Act (RCRA) characteristic hazardous waste, or by the methodology required by the disposal facility. Based on past response actions at this Site, it is anticipated that the results will show that it is not a hazardous waste. Any excavated soil and sediment with characteristics requiring it to be classified as RCRA hazardous waste will be treated pursuant to RCRA requirements (40 CFR 258) prior to disposal in an offsite Subtitle D landfill. The approximately 3,600 cubic yards of soil which met the site specific leaching cleanup goals but exceed the default direct exposure

cleanup goals noted in Table 5 would be excavated, transported to and consolidated on the FFF property and compacted to construct an engineered cap. This alternative also includes perforating and backfilling the depressed loading ramp on the Landia property to prevent the ramp from filling with water.

After excavation was completed, confirmation samples would be taken to ensure the cleanup goals were achieved. The excavated areas would then be backfilled and graded appropriately. Backfill material may be amended with lime or limestone to increase the buffering capacity of the soil. The depressed loading ramp on the Landia property would be perforated and backfilled to match the surrounding ground surface to prevent the ramp from collecting water.

Institutional controls in the form of restrictive covenants would be placed on the Landia and former FFF properties to limit the future use of the properties to industrial and to limit future construction activities to prevent the potential exposure to any contaminated soil remaining under building foundations. Institutional controls would also require regular inspection of the engineered cap any other relied upon engineered barriers (e.g. concrete slabs, asphalt caps) to be maintained to prevent exposures to impacted soil.

It is anticipated that Alternative S3 would remove the contaminants of concern that exceed the site-specific leaching cleanup goals and minimize contaminants from migrating into the groundwater. Soils exceeding the default direct exposure cleanup levels (industrial and residential) would remain on-site under an engineered cap to prevent the potential for direct exposure.

The costs associated with Alternative S3 are:

- Estimated construction costs: \$4,861,000
- Estimated O&M costs: \$0
- Total present worth cost: \$4,861,000 (using a discount rate of 7%)
- Estimated Construction Timeframe: 9 months
- Estimated Time to Achieve RAOs: 9 months

9.4 Groundwater Interim Action: In-Situ Treatment of Groundwater Using Chemical Oxidation of Areas with Elevated Levels of Pesticide Groundwater Contamination and Bioremediation of Elevated Residuals above NADCs.

The Groundwater Interim Action alternative consists of the following components:

- Installation of injection wells;
- Chemical oxidation injections in source area;
- In-situ bioremediation injections selected areas;
- Development of a performance monitoring plan to monitor and evaluate the effectiveness of the interim action; and
- Institutional controls;

Many studies have been conducted at the Landia Chemical site to determine groundwater conditions and evaluate potential remedial actions. These include a pH Adjustment Pilot Test in 2003, a Biogeochemical Evaluation in 2003-2004, a Chemical Oxidation Treatability Evaluation in 2004, and additional groundwater sampling in 2004 and 2006. While these studies have yielded much information about the contaminated groundwater and what treatment technologies may be effective, they do not provide enough information to select all the components of a final, site-wide remedy for groundwater. Therefore, an interim action was developed to address the most contaminated areas of groundwater combined with continued data collection in the areas of lower contamination. After the effectiveness of this interim action has been evaluated and more historical trends developed, another proposed plan and ROD would be issued selecting the final site-wide groundwater remedy.

Generally, groundwater contaminant concentrations are highest north of Olive Street underneath the industrial properties. In order to accomplish the goal of treating the most contaminated groundwater, the interim action would be implemented to treat all contaminated groundwater north of Olive Street which exceeds the Florida Natural Attenuation Default Criteria (NADCs) as shown in Figure 7. Treating all contaminated groundwater north of Olive Street above NADCs combined with one of the evaluated soil remedies is expected to have a beneficial impact on groundwater contaminant concentrations. The interim action would use in-situ chemical oxidation (injection of an oxidant to treat the targeted pesticide contaminants in the groundwater) to address areas with elevated levels of pesticide groundwater contamination selected during the remedial design and in-situ bioremediation (injections to enhance biologically assisted degradation) in all other areas in order to reduce contaminant concentrations to below the NADCs.

The injection process would involve installation of closely spaced injection wells. The required oxidants would be injected in 3 injection events. Following chemical oxidation, a polishing treatment may be required to address residual COCs and some of the oxidized metals. If required, this treatment would include injections to enhance biologically assisted degradation (in-situ bioremediation) which would use the injection wells installed for chemical oxidation. It is assumed that in-situ bioremediation would be implemented for approximately 2 years following chemical oxidation.

The available groundwater data indicate areas with elevated nitrate levels on the former FFF property in the vicinity of the storage and blending operations. In-situ bioremediation would be employed by creating anaerobic conditions in the aquifer to reduce the nitrates to nitrites and finally to nitrogen (denitrification). Nitrate reduction will be accomplished with periodic injections of carbohydrates using a direct push rig in the areas with elevated nitrate levels on the FFF property.

The active treatment of these source areas should further reduce the contaminant concentrations of less-impacted areas of groundwater located downgradient. Groundwater monitoring will be conducted to determine the effectiveness of the soil removal and the interim groundwater action (in-situ oxidation and bioremediation) in reducing contaminant concentrations and to support selection of the final groundwater remedy. Evaluation of the monitoring data will be conducted by both EPA and DEP on a yearly basis and at the five-year review timeframe. The five year

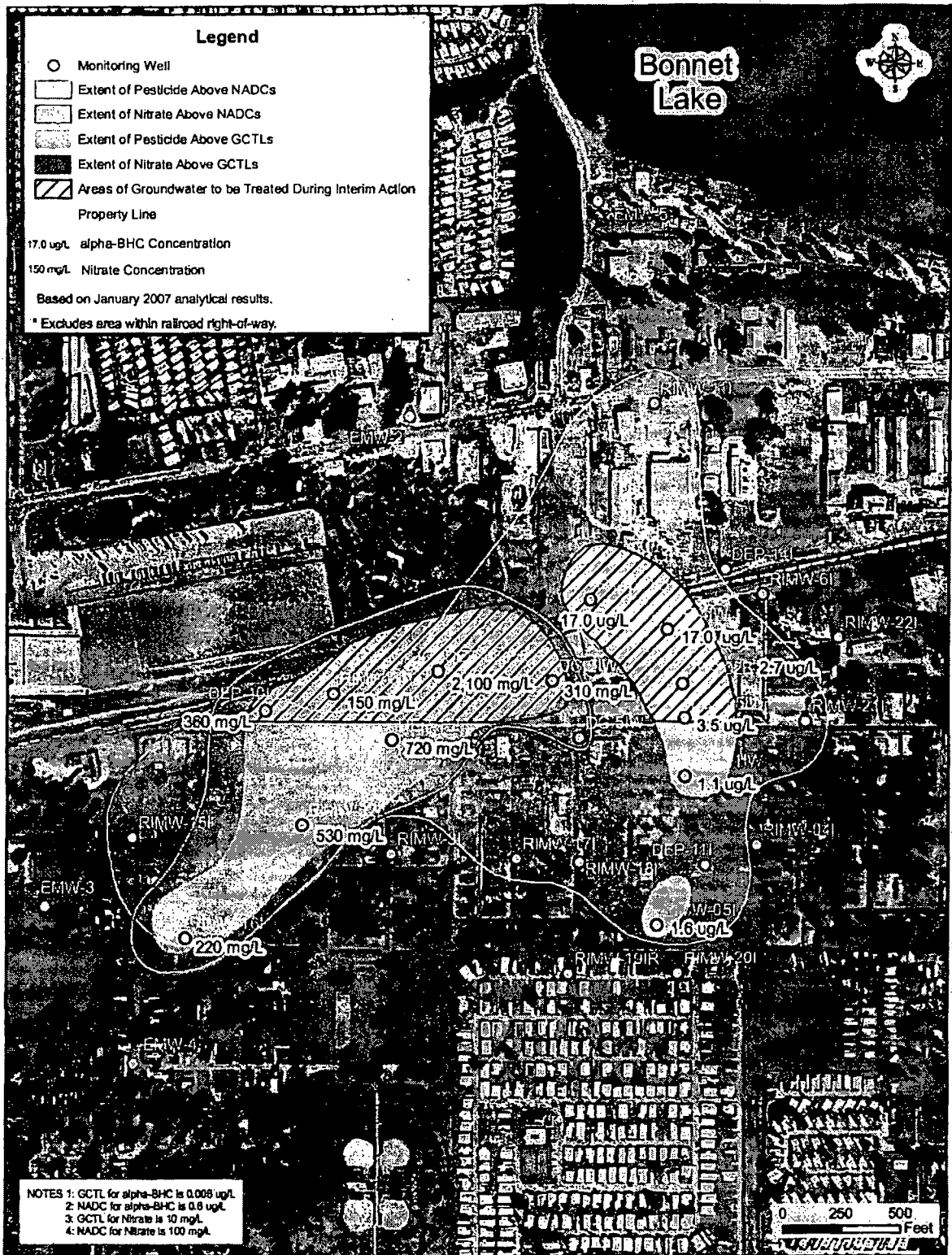

Figure 7 – Area of Groundwater Treatment

review period encompasses completion of the interim groundwater action and supporting groundwater pilot studies necessary for evaluation and selection of the final groundwater remedy.

Institutional controls will be used in order to ensure protectiveness during implementation of the interim groundwater remedy. Institutional controls are non-engineering instruments such as administrative or legal controls that eliminate or minimize the potential of human exposure to contaminants and chemicals of concern and to protect the integrity of the remedy by limiting land or resource utilization. The specific Institutional Controls for the Site will be established as part of the Remedial Design. During the Remedial Design, an Institutional Controls Implementation Plan will be developed to more clearly detail and describe the objective, mechanism, timing, and responsibility for the Institutional Controls to be implemented at the Site. The Institutional Controls will eliminate potential exposure at the Site property to the impacted soil and groundwater and to the impacted groundwater at other properties.

Institutional controls in the form of restrictive covenants would be placed on the former FFF and Landia properties by the site owners to limit future use of the properties to commercial/industrial and to restrict use of the groundwater until groundwater cleanup standards have been reached. The restrictive covenants may also require certain engineered controls (such as asphalt caps or concrete slabs) to be maintained to prevent potential future exposure to impacted soils underneath. Construction activities may be limited on these two properties to prevent exposure of impacted soils remaining under building foundations or require that the activities be conducted with FDEP approval.

Institutional controls may be used as the principal tool for preventing human exposure to contaminated groundwater at and downgradient of the Site. Maintenance of institutional controls is an essential component of the selected remedy and is necessary to prevent future risk resulting from consumption of contaminated groundwater. In order to ensure protectiveness during implementation of the interim groundwater remedy, access to impacted groundwater beneath and surrounding the Site will be restricted. A primary groundwater Institutional Control will be strict prohibition of drilling of wells and use of impacted groundwater in the area. Institutional Controls for impacted groundwater may include reliance on existing authorities of the FDEP, the South Water Florida Water Management District (SWFWMD), and various local government authorities. At a minimum, the Institutional Controls may include:

- In 1999, the Florida Department of Health (FDOH) conducted a Public Health Assessment and issued a Contaminated Groundwater Advisory for the residential area south of the Site. In the Public Health Assessment, FDOH requested that the Southwest Florida Water Management District (SWFWMD), the agency responsible for issuing permits for the construction of all new wells in the area, restrict permits for new well construction near the area of groundwater contamination.
- Florida Administrative Code 64E-8.003 contains requirements for the construction of any new private potable wells in Florida. It requires all new private potable wells to be separated from major contaminant sources. It also requires the groundwater be analyzed for contaminants if the wells are proposed to be constructed within 1000 feet of a known contaminant source.
- Florida Administrative Code 40D-3.305 confers to the SWFWMD the authority to deny a permit application to construct a water well if use of the well would increase the potential for harm to public health safety and welfare, or if the proposed well would degrade the

water quality of the aquifer by causing pollutants to spread. EPA plans to notify SWFWMD of the area of impacted groundwater so that no wells will be allowed in the area unless it complies with SWFWMD requirements. EPA will periodically provide updates on the groundwater contaminant levels to the SWFWMD at least every five years or if contaminant concentrations show significant change.

- Public notice to area residents and businesses of the impacted groundwater every five years using the procedure as set forth in Florida Administrative Code 62.780.220(3).
- An inventory of area wells every five years to ensure that no new well have been installed that would expose area residents or businesses to impacted groundwater.

These regulations, advisories and restrictions prevent potential future exposure to contaminated groundwater on or surrounding the Site until the cleanup standards have been achieved.

The following are estimated costs for implementing the Groundwater Interim Action (using a 7% discount rate):

- Estimated design and predesign costs: \$248,500
- Estimated Present Worth Costs (Year 1): \$2,551,200
- Estimated Present Worth Costs (Year 2): \$874,700
- Estimated Present Worth Costs (Year 3): \$808,400
- Estimated Construction Timeframe: 1 year
- Estimated Time to Achieve RAOs: 20 years (for cost estimating purposes)

10.0 Summary of Comparative Analysis of Alternatives

The alternatives were evaluated against one another by using the following nine criteria:

- Overall protection of human health and the environment;
- Compliance with Applicable or Relevant and Appropriate Requirements (ARARs);
- Long term effectiveness and permanence;
- Reduction of toxicity, mobility, or volume through treatment;
- Short term effectiveness;
- Implementability;
- Costs;
- State acceptance; and
- Community acceptance.

The NCP categorized the nine criteria into three groups:

- **Threshold criteria:** the first two criteria, overall protection of human health and the environment and compliance with ARARs (or invoking a waiver), are the minimum criteria that must be met in order for an alternative to be eligible for selection.
- **Primary balancing criteria:** the next five criteria are considered primary balancing criteria that are used to weigh major trade-offs among alternative cleanup methods.
- **Modifying criteria:** state and community acceptance are modifying criteria that are formally taken into account after public comment is received on the Proposed Plan. Community acceptance is addressed in the responsiveness summary of the ROD.

10.1 Overall Protection of Human Health and the Environment

Overall protection of human health and the environment addresses whether each alternative provides adequate protection of human health and the environment and describes how risks posed through each exposure pathway are eliminated, reduced, or controlled, through treatment, engineering controls, and/or institutional controls.

All of the soil alternatives are protective of human health and the environment with the exception of Alternative S1 as it does not involve an active remedy to reduce risk. If the source areas are not remediated, the potential exists for exposure to humans and the environment including continued leaching of COCs into the groundwater. Alternative S2 is most protective of human health and environment because nearly all of the source material will be removed from the Site. Alternative S3 is also protective because most of the COC mass will be removed and the remaining material will be below site-specific leaching SCTLs and will be capped to minimize the potential for exposure. However, the engineered cap would require long-term maintenance and monitoring. Accidental removal or deterioration of the cap may result in exposure to contaminated soils and would compromise the protection of human health and environment.

The groundwater interim action is expected to be protective of human health and the environment in the short term due to the use of treatment technologies designed to reduce the toxicity, mobility and volume of the contaminants. Chemical oxidation is expected to

significantly reduce pesticide concentrations in the source areas at the Site. In-situ bioremediation would also be used to address the on-site areas of groundwater contaminated with nitrates and treatment residuals from chemical oxidation. Institutional controls will be used to restrict the use of contaminated groundwater.

10.2 Compliance with ARARs

Section 121(d) of CERCLA and NCP §300.430(f)(1)(ii)(B) require that remedial actions at CERCLA sites at least attain legally applicable or relevant and appropriate Federal and State requirements, standards, criteria, and limitations which are collectively referred to as "ARARs," unless such ARARs are waived under CERCLA section 121(d)(4).

Applicable requirements are those cleanup standards, standards of control, and other substantive requirements, criteria, or limitations promulgated under Federal environmental or State environmental or facility siting laws that specifically address a hazardous substance, pollutant, contaminant, remedial action, location, or other circumstance found at a CERCLA site. Relevant and appropriate requirements are those cleanup standards, standards of control, and other substantive requirements, criteria, or limitations promulgated under Federal environmental or State environmental or facility siting laws that, while not "applicable" to a hazardous substance, pollutant, contaminant, remedial action, location, or other circumstance at a CERCLA site address problems or situations sufficiently similar to those encountered at the CERCLA site that their use is well-suited to the particular site. To Be Considered (TBC) Criteria are non-promulgated advisories or guidance documents issued by federal or state governments. They do not have the status of ARARs but can be considered in determining the necessary level of cleanup for the protection of human health or the environment. Compliance with ARARs addresses whether a remedy will meet all of the applicable or relevant and appropriate requirements of other Federal and State environmental statutes or provides a basis for invoking a waiver.

Location-specific ARARs are restrictions placed on the concentration of hazardous substances to the conduct of activities solely on the basis of location. No location specific ARARs were identified at this Site.

Action-specific ARARs are technology- or activity-based requirements or limitations on actions taken with respect to hazardous wastes. These requirements are triggered by the particular remedial activities that are selected to accomplish a remedy. EPA considers the applicable or relevant and appropriate provisions of the statutes, rules, regulations, and requirements contained in Table 3 as action specific ARARs.

Chemical-specific ARARs are specific numerical quantity restrictions on individually-listed contaminants in specific media. Examples of chemical-specific ARARs include drinking water standards and ambient air quality standards. Because there are usually numerous contaminants of potential concern for any remedial site, various numerical requirements can be ARARs. In most cases for this remedy, EPA has chosen to incorporate FDEP SCTLs (Soil Cleanup Target Levels) and GCTLs (Groundwater Cleanup Target Levels) found in Florida Chapter 62-777 F.A.C. to satisfy the ARAR of attaining a 1×10^{-6} risk level for carcinogens and a hazard index of 1 or less for noncarcinogens (Florida Statute Chapter 376) when they existed for Site COCs, where they were developed based on health based criteria, and were derived using currently accepted risk assessment assumptions and processes utilized by the CERCLA program. EPA considers the applicable or relevant and appropriate provisions of the statutes, rules, regulations, and requirements contained in Table 4 as chemical specific ARARs.

Table 3 - Action-Specific ARARs

Requirement	Citation	Description	Comments
Construction Standards	29 CFR 1929	Establishes occupational safety and health standards for the construction industry	Applicable for remedial actions involving construction and excavation to certain depths.
Occupational Safety and Health Administration Regulations	29 CFR Parts 1904, 1910, and 1926	Occupational safety and health requirements applicable to workers engaged in onsite work during implementation of remedial actions	Applicable to soil and groundwater remedial actions.
Hazardous Waste Operations and Emergency Response	29 CFR 1910	Defines health and safety procedures necessary during remedial investigations and cleanup	Applicable. All proposed site activities need to provide an adequate level of worker protection.
Identification and listing of hazardous waste	40 CFR 261 et. seq.)	Defines those solid wastes that are subject to regulation as hazardous wastes under 40 CFR 262-265, and 124, 127, and 271	Applicable if hazardous wastes are generated on site as a result of cleanup activities.

Table 3 - Action-Specific ARARs

Requirement	Citation	Description	Comments
Standards applicable to generators of hazardous waste	40 CFR 262	Establishes standards for generators of hazardous waste that address waste accumulation, preparation for shipment and completion of the uniform hazardous waste manifest.	Applicable if remedial actions involve generation of hazardous waste.
Standards applicable to owners/operators of hazardous waste treatment, storage, and disposal facilities	40 CFR 264	Establishes minimum national standards that define the acceptable management of hazardous waste for owners and operators of facilities that treat, store, or dispose of hazardous waste.	Relevant and appropriate if remedial actions involving on-site ex-situ treatment methods for hazardous waste.
Land Disposal Restrictions	40 CFR 268	Prohibits land disposal of specified untreated hazardous wastes and provides special requirements for handling such wastes.	Land disposal treatment requirements are applicable for disposal of hazardous waste/soils on-site disposal facility.
Hazardous Materials Transportation Act; Hazardous Material Transportation Regulations	44 USC 1801-1813; 40 CFR 107-171-177	Regulates transportation of hazardous materials	Applicable for offsite transportation of hazardous materials/soils.

Table 4 - Chemical-Specific ARARs

Requirement	Citation	Description	Comments
Safe Drinking Water Act: National Primary Drinking Water Standards	40 CFR 141	Establishes health-based standards for public water systems (maximum contaminant level goals (MCLGs) and maximum contaminant levels (MCLs).	Applicable to potential drinking water sources.
Resource Conservation and Recovery Act (RCRA)	40 CFR 268	Establishes treatment standards based on best demonstrated available technology for treatment of hazardous wastes.	May be applicable to off-site treatment of impacted soils.
RCRA Toxicity Characteristic Rule	40 CFR 261	Establishes levels of chemicals which would harm human health or the environment if the waste was mismanaged.	Applicable to characterizing soils exceeding TCLP criteria.
Clean Air Act: National Primary and Secondary Ambient Air Quality Standards (NAAQS)	40 CFR 50	Establishes standards for ambient air quality to protect public health and welfare.	May be relevant and appropriate during a remedial action (e.g., soil excavation and particulate entrainment in wind & thermal destruction).
Clean Air Act: National Emissions Standards for Hazardous Air Pollutants (NESHAP)	40 CFR 61	Sets emission standards for pollutants for which no Ambient Air Quality Standards exist.	May be relevant & appropriate if hazardous air pollutant are emitted during a remedial action.

Table 4 - Chemical-Specific ARARs

Requirement	Citation	Description	Comments
Federal Water Pollution Control Act: USEPA Ambient Water Quality Criteria (AWQC)	33 USC A26; 40 CFR 131	Objectives are to restore and maintain the chemical, physical, and biological integrity of the nation's waters.	May be relevant and appropriate when modified to reflect the designated or potential use of the affected waters, the media affected, and the purpose of the criteria.
Contaminated Site Cleanup Criteria	Florida Statute Chapter 376.3071(g)(1)-(3) for groundwater and (i)(1)-(3) for soil.	Requires cleanups of contaminated soil and groundwater in the State of Florida to reduce the excess lifetime cancer risk to 1×10^{-6} for carcinogens and a hazard index of 1 or less for noncarcinogens.	Applicable.
FDEP Drinking Water Standards	F.A.C. Chapter 62-550	Establishes MCLs for contaminants in public water systems.	Applicable.
Florida Surface Water Quality Standards	F.A.C. Chapter 62-302	Establishes standards of quality for all surface waters in the state. Also, allows for site-specific alternative criteria for water bodies that may not meet a particular ambient water quality criterion applicable to the classification of the water body due	Applicable.

Table 4 - Chemical-Specific ARAAs

Requirement	Citation	Description	Comments
Regulation of Wells	Chapter 40D-3	Southwest Florida Water Management District (SWFWMD) rules govern the construction of water wells.	Applicable for construction of monitoring wells
Air Pollution Control - General Provision	F.A.C. Chapter 62-204	Establishes maximum allowable levels of pollutants in the ambient air, or ambient air quality standards, necessary to protect human health and public welfare.	May be relevant and appropriate during a remedial action (e.g., soil excavation and particulate entrainment in wind, thermal destruction).

All alternatives, except the no-action alternatives, had common ARARs associated with the soil and ground-water remediation goals. All soil alternatives are expected to meet ARARs with the exception of Alternative S1. Alternatives S2 and S3 are expected to comply with chemical specific ARARs as long as proper procedures are followed. These ARARs include compliance with industrial/leaching or residential cleanup goals, OSHA regulations for PPE, DOT regulations for transportation of impacted soil, CERCLA and RCRA requirements for disposal of impacted soil, OSHA requirements of excavation, FDEP and county erosion and sedimentation control requirements and air quality/emission requirements.

The groundwater interim action is expected to substantially reduce groundwater contaminant concentrations but is not expected to achieve drinking water standards. After evaluation of the effectiveness of the interim action, a final action will be chosen that meets all ARARs.

10.3 Long Term Effectiveness and Permanence

Long-term effectiveness and permanence refers to the expected residual risk and the ability of a remedy to maintain reliable protection of human health and the environment over time, once cleanup levels have been met. This criterion includes the consideration of residual risk that will remain on-site following remediation and the adequacy and reliability of controls.

Each alternative, except the No Action alternative provides some degree of long term protection. Alternatives S2 and S3 would be effective upon completion of construction activities. The long term effectiveness of alternative S2 is greatest because the source material would be removed and disposed of off-site at a permitted facility. While alternative S3 does provide significant long term effectiveness, some residual risk would exist due to consolidation and capping of untreated soils that meet the site-specific leaching cleanup goals but do not meet the direct exposure cleanup goals. Both alternatives S2 and S3 would require some level of controls or long-term management as some isolated spots of contaminated soils that are under building footings/foundations and an engineered cap, respectively, would not be removed. However, Alternative S3 is less permanent due to consolidation of impacted soils under an engineered cap at the FFF property.

Among all the alternatives, Alternative S2 appears to have the greatest long term effectiveness and permanence.

The groundwater interim action is expected to enhance the long term effectiveness of the final groundwater remedy due to the active treatment of groundwater in areas demonstrating the most significant contaminant concentrations. Chemical oxidation and in-situ bioremediation technologies have been successfully used for the remediation of organic and inorganic constituents. Due to active treatment, the duration of the final groundwater remedy is expected to be shorter. Long-term monitoring programs and Five-Year Reviews will be required to evaluate the effectiveness and protectiveness of the groundwater interim action. Institutional controls (e.g., restrictive covenants and groundwater use restrictions) would be implemented until groundwater cleanup goals are met.

10.4 Reduction of Toxicity, Mobility, or Volume through Treatment

Reduction of toxicity, mobility, or volume through treatment refers to the anticipated performance of the treatment technologies that may be included as part of the remedy.

Alternative S1 has no impact on reduction in toxicity, mobility, or volume other than that reduced by natural processes. Alternatives S2 and S3 reduce the toxicity, mobility and volume

of impacted soil at the Site. Any excavated soil and sediment with characteristics requiring it to be classified as RCRA hazardous waste will be treated pursuant to RCRA requirements (40 CFR 268) prior to disposal in an offsite Subtitle D landfill. Alternative S2 results in essentially complete removal of the impacted soil above industrial criteria from the Site and disposal at an off-site facility. Since the soils in this alternative will be disposed of at a permitted facility (e.g., Subtitle D landfill), the mobility is expected to be reduced by the implementation of proper control measures at that facility.

Although mobility will be reduced in Alternative S3 due to the same reasons as for Alternative S2, some reduction in mobility is also offered by capping.

The groundwater interim action offers a reduction of toxicity, mobility and volume with treatment of the contaminants in the areas of most significant groundwater impacts via chemical oxidation and in-situ bioremediation.

10.5 Short Term Effectiveness

Short-term effectiveness addresses the period of time needed to implement the remedy and any adverse impacts that may be posed to workers, the community and the environment during construction and operation of the remedy until construction of remedial components is completed and cleanup levels are achieved.

Alternative S1 requires no intrusive work, but is not an effective remedy. Risk to workers during implementation of Alternatives S2 and S3 include exposure to source material. However, this risk would be minimized by the use of proper health and safety procedures. Engineering controls (dust suppression and erosion control) would significantly minimize exposure to contaminants and would be protective to the community. These controls would be required for Alternatives S2 and S3. Alternatives S2 and S3 are expected to have some impact on the community. The generation of dust from excavation and backfilling and increased risk of accidents would be due to increased truck traffic. There is the possibility of a release of contaminants to the environment as a result of potential traffic accidents involving a haul truck. This is not a common occurrence and the magnitude of impact should be low based on experience gained during the 2000 removal action. Construction activities for Alternative S2 and S3 are expected to be completed in 6 months and 9 months respectively, with Alternative S3 taking slightly longer for construction of the cap.

The groundwater interim action requires the installation of groundwater monitoring and/or injection wells, which may pose a risk of exposure to impacted soil and groundwater by workers and the community. The potential risk of exposure to the local community from groundwater usage during implementation of the interim action would be minimized or eliminated through institutional controls. The interim action involves the installation of injection wells, reagent tanks, and delivery systems, in addition to monitoring wells. The risk of exposure to chemicals and impacted groundwater for workers exists for the groundwater interim action, including the risks posed by the exothermic reaction during chemical oxidation. These risks would be reduced through implementation of proper procedures and the use of appropriate health and safety measures. These risks would not be present to the general public since the interim action would be conducted in on-site areas that are fenced and locked.

10.6 Implementability

Implementability addresses the technical and administrative feasibility of a remedy from design through construction and operation. Factors such as availability of services and materials, administrative feasibility, and coordination with other government entities are also considered.

Alternative S1 is readily implementable because no construction activity is required. Alternatives S2 and S3 are easily implementable. The excavation components of these alternatives can be implemented using standard construction equipment and techniques and have been demonstrated effective at the facility during previous removal actions. Alternative S3 includes the construction of an engineered cap, which also uses standard engineering and construction methods.

The groundwater interim action is labor intensive due to the processes of chemical oxidation and in-situ bioremediation, but is easily implementable. The installation of injection wells and the process for chemical injection and in-situ bioremediation can be implemented using standard construction equipment and techniques.

The institutional control components of all remedies have been analyzed and determined to be implementable. Institutional controls associated with the groundwater remedy would require the cooperation of the State and Local governments. The Florida Administrative Code has been reviewed to determine responsibilities and requirements for the installation of new private wells. The Southwest Florida Water Management District (SWFMD) has been informed about the groundwater contamination from the Site.

10.7 Costs

Cost estimates for each alternative were calculated based on conceptual engineering and design. The type of costs that were assessed included:

- capital costs, including both direct and indirect costs;
- annual O&M; and
- total present worth costs.

The present worth cost of each soil alternative provides the basis for the cost comparison. Total present worth cost was calculated by combining the capital cost plus the present worth of the annual O&M costs. Capital cost includes engineering and design, mobilization, site development, equipment, construction, demobilization, utilities, and sampling/analyses. Operating costs were calculated for activities that continue after completion of construction, such as routine operation and maintenance of treatment equipment, and groundwater monitoring. The present worth of an alternative is the amount of capital required to be deposited at the present time at a given interest rate to yield the total amount necessary to pay for initial construction costs and future expenditures, including O&M and future replacement of capital equipment. The total present worth cost was developed using a discount rate of 7 percent. Each of the soil alternatives should meet cleanup goals within one year. Present worth costs needed to meet performance standards are within the range of +50% to -30% accuracy. If the total volume of materials to be excavated and disposed of change from current estimates, the cost estimate associated with these remedial components would change. Of the soil alternatives, Alternative S3 is the most expensive alternative. Alternative S2 is the least expensive option.

10.8 State Acceptance

The State of Florida, as represented by the FDEP, has been the support agency during the Remedial Investigation and Focused Feasibility Study (RI/FFS) process for the Landia Site. In accordance with 40 C.F.R. § 300.430, FDEP as the support agency, has provided input during this process by reviewing major documents in the Administrative Record. At this time, the FDEP concurs with the selected remedy.

10.9 Community Acceptance

EPA held a public meeting to discuss the proposed remedy on July 10, 2007. During the public comment period, the community generally supported the selection of Alternative S2. Specific responses to issues raised by the community can be found in Appendix A, The Responsiveness Summary.

11.0 Principal Threat Wastes

The NCP establishes an expectation that EPA will use treatment to address the principal threats posed by a site wherever practicable (NCP §300.430(a)(1)(iii)(A)). The "principal threat" concept is applied to the characterization of "source materials" at a Superfund site. A source material is material that includes or contains hazardous substances, pollutants or contaminants that act as a reservoir for migration of contaminants to ground water, surface water or air, or acts as a source for direct exposure. Contaminated ground water generally is not considered to be a source material. Principal threat wastes are those source materials considered highly toxic or highly mobile that generally cannot be reliably contained, or would present a significant risk to human health or the environment should exposure occur.

Most principal threat wastes that were originally present at the Site were removed during the previous removal actions. The remaining principal threat wastes are in the subsurface soil just above the water table. If not addressed, these remaining principal threat wastes would likely migrate into the groundwater at levels well above drinking water standards and significantly increase the amount of time needed to achieve cleanup standards. The remaining principal threat wastes will be addressed through excavation.

12.0 Summary of Selected Remedy

12.1 Summary of Rationale for the Selected Remedy

Based upon consideration of the requirements of CERCLA, the NCP, FDEP regulations, the detailed analysis of alternatives and public and state comments, EPA has selected Soil Alternative S2 as the final action for soil, an interim action to address groundwater contamination, and implementation of various institutional controls to ensure future protectiveness.

Soil Alternative S2 (excavation and offsite disposal) the selected final remedy to address soil contamination. Alternative S2 is more protective of human health and the environment compared to Alternatives S1 and S3. Its comparative advantage over the other soil alternatives is that the majority of the soils impacted above the cleanup goals in Table 5 will be removed from the Site thus allowing for substantive elimination of remaining source materials as well as relatively unrestricted industrial use (except for some impacted soils remaining under building footings/foundations) for the first year of implementation. Alternative S1 does not comply with ARARs and is thus not protective. Alternative S3 leaves impacted soils on Site and requires long-term care similar to a solid waste landfill. Alternative S3 significantly restricts use of a significant area of the former FFF property compared to Alternative S2. The present worth cost of Soil Alternative S2 is \$4,021,400 which makes it also slightly less expensive than alternative S3.

EPA is selecting an interim action to address groundwater contamination. Many studies have been conducted at the Site to determine site groundwater conditions and evaluate potential groundwater remedial actions. These include a pH Adjustment Pilot Test in 2003, a Biogeochemical Evaluation in 2003-2004, a Chemical Oxidation Treatability Evaluation in 2004, and additional groundwater sampling in 2004 and 2006. While these studies have yielded much information about the contaminated groundwater and what treatment technologies may be effective, they do not provide enough information to select all the components of a final, site-wide remedy for groundwater. The interim action will treat the most contaminated groundwater via in-situ chemical oxidation and in-situ bioremediation and continued to collect samples in the areas of lower contamination. After the effectiveness of this interim action has been evaluated and more historical trends developed, another proposed plan and ROD will be issued selecting the final site-wide groundwater remedy.

In order to ensure future protectiveness, this ROD selects the implementation of various institutional controls. Institutional controls will be implemented to ensure the future use of the Landia and former FFF properties remain industrial, to restrict the use of contaminated groundwater, and to ensure any engineering barriers that are relied upon are maintained.

12.2 Description of the Selected Remedy

12.2.1 Selected Soil Remedy

12.2.1.1 Excavation of soils exceeding Cleanup Goals

The excavation and off-site disposal of soil alternative (S2) is designed to address the impacted shallow and subsurface soil which exceed the cleanup goals shown in Table 5. Alternative S2 involves the excavation of contaminated soil using mechanical equipment. Approximately 13,289 cubic yards (cy) of soil will be excavated on the former FFF parcel, an estimated 7,980 cy of soil will be excavated on the Landia property and an estimated 2,021 cy of soil and sediments will be excavated from localized areas south of Olive Street for an estimated total of 23,290 cubic yards of excavated soil. The volume of contaminated soil to be excavated includes the contaminated soil estimated to be under paved surfaces at the Landia property. The actual limits of contamination will be determined during the remedial design phase, and during the remedial action through confirmation sampling to be conducted after excavation activities occur. In addition to collecting confirmation samples for attaining the cleanup goals in Table 5, confirmation samples will also be collected and evaluated for sulfur concentrations in the area of historical bulk sulfur storage to ensure most of the sulfur is removed. This should have a beneficial effect on raising the pH in the soil and shallow groundwater. The depressed loading ramp on the Landia property will be perforated and backfilled to match the surrounding ground surface to prevent the ramp from collecting water. Engineering measures such as dewatering of excavation areas may be required to allow excavation work to proceed. Any water removed would be contained, analyzed, treated if necessary and properly disposed.

12.2.1.2 Transportation and off-site disposal of excavated soils

Once the soil is excavated and stockpiled, confirmation samples will be collected to verify that the remaining soils meet proposed soil cleanup goals found in Table 5. In addition, the stockpiled material will be characterized for disposal at an appropriate permitted off-site disposal facility. Excavated soil would be sampled and analyzed to determine if it is a RCRA characteristic hazardous waste. Based on past response actions, it is anticipated that the results will show that it is not a hazardous waste. Any excavated soils and sediments with characteristics requiring it to be classified as RCRA hazardous waste will be treated pursuant to RCRA requirements (40 CFR 268) prior to disposal in an offsite Subtitle D landfill. The stockpiled soil will be placed on and covered by plastic to prevent dispersion. The impacted soil is assumed to be non-hazardous soils based on the information from the 2000 Removal Action.

12.2.1.3 Backfill and grading

After removal and disposal, the excavated areas will be backfilled and graded appropriately for proper site drainage. The backfill may be amended with lime or limestone in some areas to increase the buffering capacity of the soil. At a minimum, backfill will be sampled to ensure it meets the cleanup goals found in Table 5.

12.2.2 Interim Action for Groundwater

Generally, groundwater contaminant concentrations are highest north of Olive Street underneath the industrial properties. In order to accomplish the goal of treating the most contaminated groundwater, the interim action will be implemented to treat all contaminated groundwater north of Olive Street which exceeds the Florida Natural Attenuation Default Criteria (NADCs). Treating all contaminated groundwater north of Olive Street above NADCs combined with one

of the evaluated soil remedies is expected to have a beneficial impact on groundwater contaminant concentrations. The interim action will use in-situ chemical oxidation to address areas with elevated levels of pesticide groundwater contamination selected during the remedial design and in-situ bioremediation in all other areas of the treatment area in order to reduce contaminant concentrations to below the NADCs. The active treatment of these source areas should further reduce the contaminant concentrations of less-impacted areas of groundwater located downgradient. Groundwater monitoring will be conducted to determine the effectiveness of the soil removal and the interim groundwater action (in-situ oxidation and bioremediation) in reducing contaminant concentrations and to support selection of the final groundwater remedy.

12.2.2.1 Chemical oxidation injections in source area

In-situ chemical oxidation will be implemented to address areas with elevated levels of pesticide groundwater contamination within the treatment area. These areas with elevated levels of pesticide groundwater contamination will be selected during the remedial design. Chemical oxidation is an in-situ remedial treatment process that can be used to oxidize organic compounds to carbon dioxide, water and salts. The chemical oxidation treatability study indicated that an oxidizing reagent was effective in reducing the concentrations of BHCs and SVOCs in the groundwater samples. The reagent would be injected into the contaminated subsurface to produce hydroxyl radicals that attack and oxidize chlorinated pesticides, SVOCs, and non-chlorinated organics (e.g., ethyl benzene and total xylenes). During the oxidation process, some metals naturally occurring in groundwater may be oxidized as well; however, in low pH areas, metal oxidation has likely already occurred.

Presence of high organic carbon and inorganic species in soil and groundwater can act as oxidant sinks. Therefore, a field pilot study will be conducted during the remedial design to estimate the oxidant requirements, to determine the area to be treated via chemical oxidation, and to evaluate effectiveness of the treatment process prior to full-scale implementation.

The injection process involves installation of closely spaced injection wells. For the purpose of costing, the areas with elevated levels of pesticide groundwater contamination to be treated include approximately 20,000 square feet (sf) of area near the former sulfur pile (near wells FF-4R and FF4-IW) and 14,000 sf of area near the northern Landia property (near well LC112 IW). The required oxidants will be injected in three (3) injection events over approximately one year.

Following chemical oxidation, a polishing treatment may be required to address residual COCs and some of the oxidized metals. If required, this treatment would include injections to enhance biologically assisted degradation (in-situ bioremediation) which would use the injection wells installed for chemical oxidation

12.2.2.2 In-situ bioremediation injections

Following chemical oxidation, in-situ bioremediation will be used to address areas of pesticide contamination adjacent to the areas with elevated levels of pesticide groundwater contamination. This step will assist in reducing the majority of the oxidized heavy metals (e.g., chromium) and allow them to precipitate in-situ. This treatment will use the injection wells installed for oxidation for injections to enhance biologically assisted degradation (in-situ bioremediation). It is assumed that in-situ bioremediation will be implemented for approximately 2 years following chemical oxidation.

The RI data indicate there are areas with elevated nitrate levels on the FFF property in the vicinity of the storage and blending operations. These areas will be refined if necessary during

the remedial design. In-situ bioremediation will be employed by creating anaerobic conditions in the aquifer (through enhanced in-situ bioremediation) to reduce the nitrates to nitrites and finally to nitrogen (denitrification). Nitrate reduction will be accomplished with periodic injections of carbohydrates using a direct push rig in the areas of elevated nitrate levels on the FFF property. For the purpose of costing, it was estimated that carbohydrate solution would be injected at approximately 50 locations using a direct push rig on a quarterly basis for approximately 2 years.

12.2.2.3 Performance Monitoring Plan

Groundwater monitoring will be conducted to determine the effectiveness of the soil removal and the interim groundwater action (in-situ oxidation and bioremediation) in reducing contaminant concentrations and to support selection of the final groundwater remedy. Groundwater monitoring of 31 monitoring wells is occurring at the Site consistent with the approved groundwater monitoring plan dated February 2006. Sampling includes collection of water levels; analysis for pesticides, volatile organic compounds, semi-volatile organic compounds, metals, sulfates, and nitrates; and collection of various water quality parameters including dissolved oxygen, pH, temperature, conductivity, oxygen reduction potential, and turbidity. A baseline groundwater monitoring event occurred in October 2006 and the first quarterly sampling even occurred in January 2007. Quarterly sampling will continue for one year and then it is anticipated that sampling will continue on a semi-annual basis. The focus of the groundwater monitoring will continue to be to evaluate plume stability and behavior but will also evaluate the effectiveness of the soil remedy and groundwater interim action and evaluate the attenuation of dissolved contaminants. A sufficient number of wells will continue to be monitored so that a comprehensive evaluation of the changing characteristics of the plume can be completed. The performance monitoring plan will also evaluate the occurrence of Monitored Natural Attenuation (MNA) consistent with EPA's guidelines for evaluating MNA.

Evaluation of the monitoring data will be conducted on a yearly basis and at the five-year review timeframe. It is anticipated that the first five year review will include an evaluation of the effectiveness of the interim groundwater action and supporting groundwater pilot studies necessary for evaluation and selection of the final groundwater remedy.

12.2.3 Institutional controls

Institutional controls are non-engineering instruments such as administrative or legal controls that eliminate or minimize the potential of human exposure to contaminants and chemicals of concern and to protect the integrity of the remedy by limiting land or resource utilization. The specific Institutional Controls for the Site will be established as part of the Remedial Design. During the Remedial Design, an Institutional Control Implementation Plan will be developed to more clearly detail and describe the objective, mechanism, timing, and responsibility for the Institutional Controls to be implemented at the Site. The Institutional Controls will eliminate potential exposure at the Site property to the impacted soil and groundwater and to the impacted groundwater at other properties.

Institutional controls in the form of restrictive covenants will be placed on the former FFF and Landia properties by the site owners to limit future use of the properties to commercial/industrial and to restrict use of the groundwater until groundwater cleanup standards have been reached. The restrictive covenants may also require certain engineered controls (such as asphalt caps or concrete slabs) to be maintained to prevent potential future exposure to impacted soils underneath. Construction activities may be limited on these two properties to prevent exposure

of impacted soils remaining under building foundations or require that the activities be conducted with FDEP approval.

Institutional controls may be used as the principal tool for preventing human exposure to contaminated groundwater at and downgradient of the Site. Maintenance of institutional controls is an essential component of the selected remedy and is necessary to prevent future risk resulting from consumption of contaminated groundwater. In order to ensure protectiveness during implementation of the interim groundwater remedy, access to impacted groundwater beneath and surrounding the Site will be restricted. A primary groundwater Institutional Control will be strict prohibition of drilling of wells and use of impacted groundwater in the area. Institutional Controls for impacted groundwater may include reliance on existing authorities of the FDEP, the South Water Florida Water Management District (SWFWMD), and various local government authorities. At a minimum, the Institutional Controls may include:

- In 1999, the Florida Department of Health (FDOH) conducted a Public Health Assessment and issued a Contaminated Groundwater Advisory for the residential area south of the Site. In the Public Health Assessment, FDOH requested that the Southwest Florida Water Management District (SWFWMD), the agency responsible for issuing permits for the construction of all new wells in the area, restrict permits for new well construction near the area of groundwater contamination.
- Florida Administrative Code 64E-8.003 contains requirements for the construction of any new private potable wells in Florida. It requires all new private potable wells to be separated from major contaminant sources. It also requires the groundwater be analyzed for contaminants if the wells are proposed to be constructed within 1000 feet of a known contaminant source.
- Florida Administrative Code 40D-3.305 confers to the SWFWMD the authority to deny a permit application to construct a water well if use of the well would increase the potential for harm to public health safety and welfare, or if the proposed well would degrade the water quality of the aquifer by causing pollutants to spread. EPA plans to notify SWFWMD of the area of impacted groundwater so that no wells will be allowed in the area unless it complies with SWFWMD requirements. EPA will periodically provide updates on the groundwater contaminant levels to the SWFWMD at least every five years or if contaminant concentrations show significant change.
- Public notice to area residents and businesses of the impacted groundwater every five years utilizing the procedure as set forth in Florida Administrative Code 62.780.220(3).
- An inventory of area wells every five years to ensure that no new well have been installed that would expose area residents or businesses to impacted groundwater.

These regulations, advisories and restrictions prevent potential future exposure to contaminated groundwater on or surrounding the Site until the cleanup standards have been achieved.

12.2.4 Final Selected Cleanup Goals

The final selected cleanup goals for soil and groundwater are found in Table 5

**TABLE 5
CLEANUP GOALS FOR SOIL AND GROUNDWATER**

Chemicals of Concern (COC)	Offsite Soil Residential Area ⁽¹⁾	Onsite Soil Industrial Area	Basis	Groundwater Cleanup Standard	Basis
	mg/kg	mg/kg		ug/L	
1,2,4-Trichlorobenzene	-	-	-	70	MCL ⁽²⁾
2,4-Dichlorophenol	-	-	-	20	Region 4 Health Based Cleanup Level ⁽³⁾
2-Chlorophenol	-	-	-	35	GCTL ⁽⁴⁾
4,4'-DDD	4.2	7	Site Specific SCTL ⁽⁵⁾	0.1	GCTL
4,4'-DDE	-	15	Industrial SCTL ⁽⁶⁾	0.1	GCTL
4,4'-DDT	2.9	11	Default Leaching SCTL ⁽⁷⁾	0.1	GCTL
4-Nitrophenol	-	1.12	Site Specific SCTL	56	GCTL
Aldrin	0.06	0.3	Industrial SCTL	-	-
alpha-BHC	0.1	0.009	Site Specific SCTL	0.006	GCTL
alpha-Chlordane	2.8	14	Industrial SCTL	-	-
Arsenic	2.1	12	Industrial SCTL	10	MCL
beta-BHC	-	0.03	Site Specific SCTL	0.02	GCTL
Cadmium	-	17	Site Specific SCTL	5	MCL
Chlordane (technical)	2.8	14	Industrial SCTL	2	MCL
Chromium	-	38	Default Leaching SCTL	100	MCL
delta-BHC	-	25.6	Site Specific SCTL	2.1	GCTL
Dieldrin	0.06	0.04	Site Specific SCTL	0.002	GCTL
Dioxin (TEQ)	-	0.00003	Industrial SCTL	-	-
gamma-BHC (Lindane)	-	0.5	Site Specific SCTL	0.2	GCTL
Heptachlor	0.2	1	Industrial SCTL	-	-
Heptachlor epoxide	0.1	0.5	Industrial SCTL	-	-
Hexachlorobenzene	-	1.2	Industrial SCTL	-	-
Lead	400	1400	Industrial SCTL	15	MCL
Methylene chloride (Dichloromethane)	-	-	-	5	MCL
Nitrate	-	-	-	10,000	MCL
Nitrite	-	-	-	1,000	MCL
Toxaphene	0.9	4.5	Industrial SCTL	3	MCL
Xylenes (total)	-	156.4	Site Specific SCTL	3500	Region 4 Health Based Cleanup Level

* See Notes Next Page

Table 5 Notes:

(-) indicates that chemical was not identified as a chemical of concern in the associated media.

1. Residential Soil Cleanup Target Levels (SCTLs) found in FAC 62-777. The residential SCTLs found in FAC 62-777 are derived in order to protect receptors from direct exposure to contaminants in soil in a residential scenario and to meet the 10-6 excess cancer risk ARAR contained in Chapter 376.3071(i)(1)-(3) and FAC 62-780.
2. Florida Maximum Contaminant Level (MCL) found in FAC 62-550.
3. Where the Florida GCTL was based on organoleptic or aesthetic values, EPA generated, health based values were used.
4. Florida Groundwater Cleanup Target Level (GCTL) found in FAC 62-777. The Florida GCTLs found in FAC 62-777 are derived in order to protect receptors from direct exposure to contaminants in groundwater and to meet the 10-6 excess cancer risk ARAR contained in Chapter 376.3071(g)(1)-(3) and FAC 62-780.
5. Site specific SCTL developed to reduce leaching of contaminants from soil to groundwater above GCTL..
6. Industrial Florida SCTL found in FAC 62-777. The industrial SCTLs found in FAC 62-777 are derived in order to protect receptors from direct exposure to contaminants in soil in an industrial worker scenario and to meet the 10-6 excess cancer risk ARAR contained in Chapter 376.3071(i)(1)-(3) and FAC 62-780.
7. Default Florida SCTL found in FAC 62-777 to protect against soil contaminants leaching into groundwater at concentrations above GCTLs.

12.3 Summary of the Estimated Remedy Costs

The cost estimate is based on the best available information regarding the anticipated scope of the remedial alternatives. Changes in the cost elements are likely to occur as a result of new information and data collected during the engineering design of the remedial alternatives. Major changes may be documented in the form of a memorandum in the Administrative Record file, an ESD, or a ROD amendment. This is an order-of-magnitude engineering cost estimate that is expected to be within +50 to -30 percent of the actual project cost. The estimated total present worth cost for the soil alternative is \$4,021,400 (Table 6). The estimated total present worth cost for the interim action for groundwater is \$4,482,800 (Table 7). The estimated total cost to implement both the soil remedial alternative and the interim action for groundwater is \$8,504,200.

All of the assumptions made, including the quantity of soil removed, the number of injection wells, the number of wells included in the performance monitoring plan and the frequency of sampling are based on the current data available at the Site. Actual costs to successfully implement these remedies may vary based on new pilot site data and/or changing Site conditions.

Table 6
Evaluation of Probable Costs for Excavation and Off-Site Disposal of Soils (Soil Alternative S2), Landia Site, Lakeland, Florida.

Description	Notes	Unit	Qty	Unit Cost (\$)	Total Cost
I. Design Services					
1 Project Management/Coordination Contract Documents/Construction Plans/Specifications/HASP	a/	ls	1	\$3,100	\$3,100
2 (excavation & SVE)		ls	1	\$20,000	\$20,000
3 Prebid meeting/contractor selection/contracting/planning		ls	1	\$8,000	\$8,000
Subtotal Design Services Costs					\$31,100
4 Contingency (20% of Design Services Costs)					\$6,220
Total Design Services Costs					\$37,320
Present Worth Design Services Costs (Year 1) (assumed to be disbursed in Year 1)	b/				\$34,900
II. Construction Costs					
1 Excavation and Off-Site Disposal					
a Mobilization/Demobilization Site Clearing/Preparation/Decon/Staging Areas	c/	ls	1	\$15,000	\$15,000
b Setup/Erosion Control	c/	ls	1	\$25,000	\$25,000
c Excavation	d/	cy	23290	\$10.00	\$232,900
d Backfill (on-site soils)	e/	cy	1391	\$3.50	\$4,870
e Backfill (clean/imported soil)		cy	21899	\$10	\$218,990
f Load (soil)	f/	cy	21899	\$3	\$65,700
g Haul/Handling of Soils/Staging (on-site)	f/	cy	23290	\$3	\$69,870
h Silt Fence (sediment control)		lf	1500	\$3.50	\$5,250
i Equipment Decontamination Decon Water/IDW Transportation & Disposal (non-hazardous)	g/	ea	30	\$250	\$7,500
j Confirmation soil sampling/analysis Miscellaneous/Warning Signs/Equipment	g/	Gal	2000	\$1	\$2,000
k Rental/Lighting/Site Cleanup	h/	ea	340	\$270	\$91,800
l Site Survey/As-Builts		ls	1	\$5,000	\$5,000
m Fill NE loading ramp (Landia Property)		ls	1	\$10,000	\$10,000
n Building Demolition (Landia Property)		cy	208	\$20	\$4,160
o Contractor Overhead/Profit (20% of Total Costs less disposal)		ls	1	\$236,000	\$236,000
p Subtotal Excavation Costs					\$1,144,800
q Off-Site Disposal of Non-Hazardous Soils (includes transportation & disposal)	i/	Ton	32,850	\$65	\$2,135,250
r Contingency (20% of Excavation and Disposal Costs)					\$656,010
Total Excavation and Off-Site Disposal Costs					\$3,936,060
Present Worth of Construction Costs (Year 1) (assumed to be disbursed in Year 1)	b/				\$3,678,600

**Table 6
Evaluation of Probable Costs for Excavation and Off-Site Disposal of Soils (Soil Alternative S2), Landia Site, Lakeland, Florida.**

Description	Notes	Unit	Qty	Unit Cost (\$)	Total Cost
III. Construction Services					
1 Engineering/Construction Oversight (20% of subtotal excavation costs)	j/	ls	1	\$229,000	\$229,000
2 Construction Completion Report	k/	ls	1	\$20,000	\$20,000
3 Health and Safety Monitoring Instruments		ls	7	\$1,500	\$10,500
4 Project Management/Coordination	l/	ls	1	\$15,000	\$15,000
Subtotal Construction Services Costs					\$274,500
5 Contingency (20% of Construction Services Costs)					\$54,900
Total Construction Services Costs					\$329,400
Present Worth Construction Services Costs (Year 1)					\$307,900
(assumed to be disbursed in Year 1)					
TOTAL PRESENT WORTH COSTS					\$4,021,400

Notes and Major Assumptions

- a/ Project management and coordinating all project related activities.
- Present worth costs were estimated based on a net annual discount rate of 7%, assuming year-end distribution normalized to year-beginning.
- b/ to year-beginning.
- c/ lump sum costs based on similar projects.
- d/ Excavation of impacted shallow soils (0 to 2 ft bls) and subsurface soils (2 - 3 ft bls) that exceed Proposed Soil Cleanup Target Levels (SCTLs).
- e/ Potentially unimpacted soils located above the subsurface impacted soils that exceed SCTLs.
- f/ Load soils on trucks for transportation; handling of soils including transportation onsite and stockpiling.
- Assume construction equipment be decontaminated 25 times and use around 100 gals/decon; decon water disposed as non-hazardous waste.
- g/ Assumed confirmation soil sampling at 50X50 grid (1 comp. Sample/grid) and 1 sample/50 ft of side wall; 1 soil sample/250 cy of soil to be hauled away
- h/ including 20 percent for QA/QC samples for analysis of chlorinated pesticide only .
- Assumes soils to be non-hazardous and hauled away and disposed at Okeechobee facility (disposal facility for Yr. 2000 removal action).
- i/ Labor and expenses to oversee and direct the excavation contractor and collecting confirmation soil samples; assumed to be 20% of the excavation cost.
- j/ A removal action report will be submitted EPA.
- k/ Project management and coordination during construction.
- l/ Estimates are based information currently available and on assumptions listed in this report.
- Costs are based on vendor information, contractors' estimate, cost estimation manuals, and past experience.
- Abbreviations: ea = each; ls = lump sum; hr = hours; cy = cubic yards; lf = linear feet; Gal - gallons; wk = week; bls = below land surface.
- Total Costs are rounded to nearest \$10 and the present worth costs are rounded to nearest \$100.

Table 7
20-Year Evaluation of Probable Costs for Treatment Train using Chemical Oxidation, In-situ Bioremediation and MNA
(Based on 2006 data), Landia Site, Lakeland, Florida.

DESCRIPTION		NOTES	UNIT	QTY	UNIT COST (\$)	TOTAL COST (\$)
I. Predesign Services						
1	Project Management/Coordination	a/	ls	1	\$13,300	\$13,300
2	Chemical Oxidation Pilot Test	b/	ls	1	\$100,000	\$100,000
3	Pilot Test Work Plan/Permitting/Negotiation		ls	1	\$10,000	\$10,000
4	Pilot Test Report Preparation		ls	1	\$10,000	\$10,000
	Subtotal Predesign Services Costs					\$133,300
5	Contingency (20% of Predesign Services Costs)					\$26,700
	Total Predesign Services Costs					\$160,000
	Present Worth of Total Predesign Costs	c/				\$149,500
	Payment Year 1					
II. Design Services						
1	Project Management/Coordination	a/	ls	1	\$9,400	\$9,400
2	Remedial Design Reports (30%, 90% & 100%)	d/	ls	1	\$75,000	\$75,000
3	Regulatory Meetings/Negotiations		ls	1	\$10,000	\$10,000
	Design Services Costs					\$94,400
4	Contingency (20% of Design Services Costs)					\$18,900
	Total Design Services Costs					\$113,300
	Present Worth of Total Design Costs	c/				\$99,000
	Payment Year 2					
III. Operation and Maintenance (O&M) Costs						
Year 1 O&M						
1	Chemical Oxidation					
a	Project Management/sub oversight/troubleshooting	a/	ls	1	\$5,700	\$5,700
b	Installation of 120 injection wells	e/	ea	120	\$1,500	\$180,000
c	IDW disposal (4 drums/well)		ea	480	\$60	\$28,800
d	Chemical Injection by Subcontractor	f/	ea	1	\$1,000,000	\$1,000,000
e	Injection oversight labor/expenses	g/	ea	3	\$10,300	\$30,900
f	Engineering Support/Data Review		ea	3	\$6,700	\$20,100
2	In-situ Bioremediation (Outside Source Area)	o/				
	Treating pesticides in outside of the ChemOX area		ls	1	\$280,100	\$330,100
	Treating pesticides north of the source area		ls	1	\$377,800	\$377,800
	Treating nitrates		ls	1	\$460,700	\$460,700
	(Includes groundwater effectiveness monitoring)					
	Subtotal Annual O&M and Monitoring Cost (Year 1)					\$2,434,100
3	Contingency (20% of Annual O&M and Monitoring Costs)					\$486,800
	Total Annual O&M and Monitoring Cost (Year 1)					\$2,920,900
	Present Worth of Annual O&M and Monitoring (Year 1 O&M)	c/				\$2,551,200
	Payment Year 2					

Table 7

**20-Year Evaluation of Probable Costs for Treatment Train using Chemical Oxidation, In-situ Bioremediation and MNA
(Based on 2006 data), Landia Site, Lakeland, Florida.**

	DESCRIPTION	NOTES	UNIT	QTY	UNIT COST (\$)	TOTAL COST (\$)
Year 2 O&M						
4	In-situ Bioremediation (Source Area)					
a	Project Management/sub oversight/troubleshooting Electron Donor Storage Tank (insulated, 5000 gal)/foundation	a/	ls	1	\$13,700	\$13,700
b			ls	1	\$18,000	\$18,000
c	Portable mixing/injection system (trailer)		ls	1	\$10,000	\$10,000
d	Misc. piping/instruments/valves/fittings		ls	1	\$10,000	\$10,000
e	Start-up		ls	1	\$10,000	\$10,000
f	Carbon Source	l/	gal	27,000	\$2.0	\$54,000
g	Potable Water	m/	gal	2,430,000	\$0.004	\$9,720
h	O&M labor	n/	hr	480	\$75	\$36,000
i	Replacement Piping/Fittings/Miscellaneous Equipment		ls	1	\$1,000	\$1,000
j	On-Site Vehicle (pickup truck) - Lease	h/	ea	12	\$300	\$3,600
k	Project Expenses (gasoline/per diem)		ea	12	\$250	\$3,000
l	Engineering Support/Data Review		ea	12	\$1,340	\$16,080
5	In-situ Bioremediation (Outside Source Area)	o/				
	Treating pesticides in outside of the ChemOX area		ls	1	\$280,100	\$330,100
	Treating pesticides north of the source area (Includes groundwater effectiveness monitoring)		ls	1	\$377,800	\$377,800
	Subtotal Annual O&M and Monitoring Cost					\$893,000
6	Contingency (20% of Annual O&M and Monitoring Costs)					\$178,600
	Total Annual O&M and Monitoring Cost					\$1,071,600
	Present Worth of Annual O&M and Monitoring (Year 2) Payment Years 3	c/				\$874,700
Year 3 O&M						
7	In-situ Bioremediation (Source Area)					
a	Project Management/sub oversight/troubleshooting Electron Donor Storage Tank (insulated, 5000 gal)/foundation	a/	ls	1	\$13,700	\$13,700
b			ls	1	\$18,000	\$18,000
c	Portable mixing/injection system (trailer)		ls	1	\$10,000	\$10,000
d	Misc. piping/instruments/valves/fittings		ls	1	\$10,000	\$10,000
e	Carbon Source	l/	gal	27,000	\$2.0	\$54,000
f	Potable Water	m/	gal	2,430,000	\$0.004	\$9,720
g	O&M labor	n/	hr	480	\$75	\$36,000
h	Replacement Piping/Fittings/Miscellaneous Equipment		ls	1	\$1,000	\$1,000
i	On-Site Vehicle (pickup truck) - Lease	h/	ea	12	\$300	\$3,600
j	Project Expenses (gasoline/per diem)		ea	12	\$250	\$3,000
k	Engineering Support/Data Review		ea	12	\$1,340	\$16,080
8	In-situ Bioremediation (Outside Source Area)	o/				
	Treating pesticides in outside of the ChemOX area		ls	1	\$280,100	\$330,100
	Treating pesticides north of the source area (Includes groundwater effectiveness monitoring)		ls	1	\$377,800	\$377,800

Table 7

20-Year Evaluation of Probable Costs for Treatment Train using Chemical Oxidation, In-situ Bioremediation and MNA
(Based on 2006 data), Landia Site, Lakeland, Florida.

	DESCRIPTION	NOTES	UNIT	QTY	UNIT COST (\$)	TOTAL COST (\$)
	Subtotal Annual O&M and Monitoring Cost					\$883,000
9	Contingency (20% of Annual O&M and Monitoring Costs)					\$176,600
	Total Annual O&M and Monitoring Cost					\$1,059,600
	Present Worth of Annual O&M and Monitoring (Year 3)	c/				\$808,400
	Payment Years 4					
	TOTAL PRESENT WORTH COSTS	c/ p/				\$4,482,800

- Notes:
- a/ Project management and coordinating all project related activities.
 - b/ Assumes installation of 10 2" PVC injection points to a depth of 30 feet and three events using Modified Fenton's Reagent.
 - c/ Present worth based on a rate of 7%, assuming year-end distribution normalized to year-beginning.
 - d/ Assumes Remedial Action Plan, Work Plan, and Interim Reports will be submitted.
 - e/ Assumes installation of 120 2" PVC wells to a depth of 30 feet.
 - f/ Assume two depths per event at 120 locations using Modified Fenton's Reagent. LANDIA = three events; FFF = three events
 - g/ Assume 30 hours of O&M per event performed by non-technical (unskilled) / trained laborers.
 - h/ Assumes \$300 per week rental per vehicle.
 - i/ Assumes sampling of 28 wells per event plus 5 QA/QC: cost includes labor
 - j/ Assumes 20 wells per event plus 2 QA/QC.
 - k/ Assumes equipment rental and expenses for sampling.
 - l/ Assumes 10 gallons of carbon source (assumes molasses for pricing) per well per event.
 - m/ Assumes 90 gallons of water per well per event.
 - n/ Assumes 40 hours of O&M per event performed by non-technical (unskilled) /trained laborers.
 - o/ Includes injection points, carbon source, equipment, and semi-annual monitoring
 - p/ Assumes 3-years of implementation of groundwater interim action will coincide with the 5-year review for the soil remedial action.
 - Costs are based on vendor information, contractors' estimate, cost estimation manuals, and past experience.
 - Abbreviations: ea = each; ls = lump sum; hr = hours; CY = cubic yards; LF = linear feet; Gal - gallons; wk = week;

12.4 Expected Outcomes of the Selected Remedy

The purpose of this response action is to protect human health and the environment by addressing the risk associated with human exposure to contaminated soil and groundwater at the Site. The soil at the Site will be restored to the more stringent of the direct exposure levels or the site-specific leachability levels. The direct exposure level will be based on industrial or residential use as appropriate for the location. Implementation of the interim groundwater action is expected to significantly reduce the highest groundwater contaminant concentrations and have a beneficial impact on those areas of lower contaminant concentrations. Table 5 presents the final cleanup goals for the soil and groundwater.

The Site is currently available for industrial/ commercial use and it is anticipated that these activities will not be restricted during the implementation of the selected remedies. Institutional controls consisting of restrictive covenants and current groundwater use restrictions will ensure future protectiveness until the cleanup goals are attained. A statutory review (5-year review) will be conducted every five years to evaluate and assess the effectiveness of the remedy.

The selected soil remedy will remove most of the contaminated soil above the cleanup goals (except soils left under building footings/foundations). The excavation and disposal will restore the soils to below the remedial goals within a year. The effectiveness of the interim groundwater action will be evaluated in the first five year review and it is anticipated that a final action to all address groundwater contamination will be selected after this evaluation.

13.0 Statutory Determinations

Under CERCLA §121 and the NCP, the lead agency must select remedies that are protective of human health and the environment, comply with applicable or relevant and appropriate requirements (ARARs)(unless a statutory waiver is justified), are cost-effective, and utilize permanent solutions and alternative treatment technologies or resource recovery technologies to the maximum extent practicable. In addition, CERCLA includes a preference for remedies that employ treatment that permanently and significantly reduces the volume, toxicity, or mobility of hazardous wastes as a principal element and a bias against off-site disposal of untreated wastes. The following sections discuss how the Selected Remedies meet these statutory requirements.

13.1 Protection of Human Health and the Environment

The selected remedies will protect human health by eliminating or controlling risks associated with human exposure to contaminated soil and groundwater at the Landia Site and surrounding areas. Soil that is impacted with COC concentrations above direct exposure and site-specific leaching criteria will be removed from the Site. Institutional controls will be implemented to retain the industrial/commercial use of the Site and prevent exposure to soils above SCTLs remaining under building footings. Groundwater will be actively treated to reduce COC concentrations. Institutional controls will be implemented to restrict the use of contaminated groundwater. The selected remedy for soil is expected to reduce contaminant concentrations to the remedial goals within approximately one year. The timeframe to reach groundwater cleanup goals will be evaluated in the final ROD that will be prepared in the future to address remaining groundwater contamination.

13.2 Compliance with ARARs

The selected remedies will be designed to comply with all of the applicable or relevant and appropriate provisions of the statutes, rules, regulations and requirements presented in Table 8.

13.3 Cost Effectiveness

In EPA's judgment, the selected remedies are cost effective and represent a reasonable value for the money to be spent. The following definition was used in making this determination: "A remedy shall be cost effective if its costs are proportional to its overall effectiveness." (40 CFR §300.430(f)(1)(ii)(D)). This was accomplished by evaluating the "overall effectiveness" of those alternatives that satisfied the threshold criteria (i.e., were both protective of human health and the environment and compliant with ARARs). Overall effectiveness was evaluated by assessing three of the five balancing criteria in combination: long-term effectiveness and permanence, reduction in toxicity, mobility, and volume through treatment, and short-term effectiveness. The relationship of the overall effectiveness of these remedial alternatives was determined to be proportional to the costs and hence represent a reasonable value for the money to be spent.

Soil Alternative S2, the selected alternative, costs less than the other soil alternative to implement. Alternative S2 provides more of a reduction in toxicity, mobility, and volume by removing a majority of the soil impacted above the cleanup goals (except for some impacted soils remaining under building footings/foundations). Alternative S2 provides a long-term effectiveness and permanence and less maintenance than Alternative S3. Alternatives S2 and S3 provide short-term effectiveness; however, with Alternative S3, some impacted soil would remain on-site beneath an engineered cap requiring long-term maintenance and institutional controls.

Table 8 – ARARs for Selected Remedy

Medium	Requirement	Citation	Status	Description	Action to Attain Requirement
	Federal				
Ground Water	Safe Drinking Water Act: National Primary Drinking Water Standards	40 CFR 141	Applicable to potential drinking water sources.	Establishes health-based standards for public water systems (maximum contaminant level goals (MCLGs) and maximum contaminant levels (MCLs).	Protecting water supplies through institutional controls.
Soil	Resource Conservation and Recovery Act (RCRA)	40 CFR 268	Applicable to off-site treatment of impacted soils.	Establishes treatment standards based on best demonstrated available technology for treatment of hazardous wastes.	Disposing of wastes at a properly licensed landfill.
Soil	RCRA Toxicity Characteristic Rule	40 CFR 261	Applicable to characterizing soils exceeding TCLP criteria.	Establishes levels of chemicals which would harm human health or the environment if the waste was mismanaged.	
Soil	Clean Air Act: National Primary and Secondary Ambient Air Quality Standards (NAAQS)	40 CFR 50	Relevant and appropriate during a remedial action (e.g., soil excavation).	Establishes standards for ambient air quality to protect public health and welfare.	Implementing best management practices during excavation (i.e., dust control).
Soil	National Emissions Standards for Hazardous Air Pollutants (NESHAPs)	40 CFR Part 61	Relevant and appropriate during a remedial action (e.g., soil excavation).	Provides emissions standards for hazardous air pollutants for which no ambient air quality standards exist. These requirements address the excavation, handling, and treatment of contaminated soil at the site.	Implementing best management practices during excavation (i.e., dust control).
Soil and surface water	Federal Water Pollution Control Act: USEPA Ambient Water Quality Criteria (AWQC)	33 USC A26; 40 CFR 131	Relevant and appropriate when modified to reflect the designated or potential use of the affected waters, the media affected, and the purpose of the criteria.	Objectives are to restore and maintain the chemical, physical, and biological integrity of the nation's waters.	Best management practices will be implemented for erosion and sediment control during the excavation.
Soil and Ground water	Construction Standards	29 CFR 1929	Applicable.	Establishes occupational safety and health standards for the construction industry	All proposed site activities will provide an adequate level of worker protection.

Medium	Requirement	Citation	Status	Description	Action to Attain Requirement
Soil and Ground water	Occupational Safety and Health Administration Regulations	29 CFR Parts 1904, 1910, and 1926	Applicable.	Occupational safety and health requirements applicable to workers engaged in onsite work during implementation of remedial actions	All proposed site activities will provide an adequate level of worker protection.
Soil and Ground water	Hazardous Waste Operations and Emergency Response	29 CFR 1910	Applicable.	Defines health and safety procedures necessary during remedial investigations and cleanup	All proposed site activities will provide an adequate level of worker protection.
Soil	Identification and listing of hazardous waste	40 CFR 261 et. seq.)	Applicable if hazardous wastes are generated on site as a result of cleanup activities.	Defines those solid wastes that are subject to regulation as hazardous wastes under 40 CFR 262-265, and 124, 127, and 271	
Soil	Standards applicable to generators of hazardous waste	40 CFR 262	Applicable if remedial action involves generation of hazardous waste.	Establishes standards for generators of hazardous waste that address waste accumulation, preparation for shipment and completion of the uniform hazardous waste manifest.	
Soil	Land Disposal Restrictions	40 CFR 268	Land disposal treatment requirements are applicable for disposal of hazardous waste/soils at a disposal facility.	Prohibits land disposal of specified untreated hazardous wastes and provides special requirements for handling such wastes.	
Soil	Hazardous Materials Transportation Act; Hazardous Material Transportation Regulations	44 USC 1801-1813; 40 CFR 107-171-177	Applicable for offsite transportation of hazardous materials/soils.	Regulates transportation of hazardous materials	
Soil	DOT Rules for Hazardous Materials Transport	49 CFR Parts 107, 171-179	Applicable if offsite shipment of hazardous wastes/ materials/ soils occurs.	Regulates the transport of hazardous materials	
Ground water	Underground Injection Control Regulations (UIC)	40 CFR 144	Applicable to injection wells used for remedial actions.	Regulates underground injection of waste and other industrial fluids	

Medium	Requirement	Citation	Status	Description	Action to Attain Requirement
	State				
Soil and Ground water	Contaminated Site Cleanup Criteria	Florida Statute Chapter 376	Applicable	Requires cleanups in the State of Florida to reduce the excess lifetime cancer risk to 1×10^{-6} for carcinogens and a hazard index of 1 or less for noncarcinogens.	
Ground water	FDEP Drinking Water Standards	F.A.C. Chapter 62-550	Applicable.	Establishes MCLs for contaminants in public water systems	Protecting water supplies through institutional controls.
Soil	Florida Surface Water Quality Standards	F.A.C. Chapter 62-302	Applicable.	Establishes standards of quality for all surface waters in the state. Also, allows for site-specific alternative criteria for water bodies that may not meet a particular ambient water quality criterion applicable to the classification of the water body due	Best management practices will be implemented for erosion and sediment control during the excavation.
Ground water	Regulation of Wells	Chapter 40D-3	Applicable for construction of monitoring wells	Southwest Florida Water Management District (SWFWMD) rules govern the construction of water wells.	
Soil	Air Pollution Control - General Provision	F.A.C. Chapter 62-204	Relevant and appropriate during a remedial action (e.g., soil excavation).	Establishes maximum allowable levels of pollutants in the ambient air, or ambient air quality standards, necessary to protect human health and public welfare.	Implementing best management practices during excavation (i.e., dust control).
Soil	Florida Hazardous Waste Rule	F.A.C. Chapter 62-730	Applicable if remedial action involves generation of hazardous waste.	Adopts by reference sections of 40 CFR concerning generation, storage, treatment, transportation and disposal of hazardous waste.	
	Regulations of Stormwater Discharge	F.A.C. Chapter 62-25	Applicable for new stormwater discharge facilities.	Regulates the discharge of untreated stormwater which may be expected to be a source of pollution of waters of the state.	
Soil	Solid Waste Management Facilities	F.A.C. Chapter 62-701	Applicable for remedial actions involving solid waste management.	Establishes standard for construction and operation & closure of solid waste management facilities to minimize threats to public health and the environment.	

Medium	Requirement	Citation	Status	Description	Action to Attain Requirement
Ground water	Underground Injection Control	F.A.C. Chapter 62-528	Applicable to injection wells used for remedial actions.	Establishes the State UIC program that is appropriate to the hydrogeology of Florida & is consistent with the requirements of Federal UIC Program.	
Soil and Ground water	Florida Well Head Protection	F.A.C. Chapter 62-521	Applicable to remedial actions in the well head protection areas.	The intent is to protect potable water wells from contamination.	

The interim action for groundwater is expected to significantly lower contaminant concentrations in the treatment area and have a beneficial impact on the residual groundwater contamination. Collection of regular groundwater data will not only evaluate the effectiveness of the interim action but will also provide critical data to select a final groundwater remedy.

13.4 Use of Permanent Solutions and Alternative Treatment Technologies to the Maximum Extent Practicable

The selected alternative for soil makes use of permanent solution to restore the soil and to below cleanup goals found in Table 5 and to levels protective of human health. The treatment alternative (S3) would provide an equal amount of permanence as the selected remedies, but is not cost effective because of the longer duration and maintenance required to achieve cleanup goals. The selected soil remedy's comparative advantage over the other soil alternatives is that the majority of the soil impacted above ARARs will be removed from the Site thus allowing for relatively unrestricted industrial use (except for some impacted soil remaining under building footings/foundations). The selected soil remedy does not use alternative treatment technologies as the preferred soil remedy because the volume of soils to be remediated is too small for such technologies to be economically viable. The remedy includes excavation and off-site disposal which is consistent with previous removal actions, and provides a permanent solution.

The interim groundwater remedy will use chemical oxidation in areas with elevated levels of pesticide groundwater contamination and in-situ bioremediation to reduce the toxicity, mobility and volume of COCs. The interim action will result in a lower residual risk, a greater reduction in toxicity and volume of COCs (with active chemical oxidation and in-situ bioremediation of areas with elevated levels of pesticide groundwater contamination) and greater effectiveness over the long-term period.

13.5 Preference for Treatment as a Principal Element

The selected soil remedy does not use treatment due to the relatively low contaminant levels of the soil to be remediated. Most principal threat wastes that were at the Site were removed during the previous removal actions. Only isolated areas of principal threat waste remain which, during the previous removal actions, were covered with two feet of fill to prevent exposures. Due to the relatively small volumes of principal threat wastes remaining, the remedial technologies considered were consistent with the removal actions and included excavation and off-site disposal.

The interim groundwater remedy satisfies the preference for treatment. The remedy will include a treatment process using chemical oxidation in areas with elevated levels of pesticide groundwater contamination and in-situ bioremediation in other areas of the treatment zone, reducing the toxicity, mobility and volume of COCs.

13.6 Five-Year Review Requirements

Because this remedy will result in hazardous substances, pollutants, or contaminants remaining on-site above levels that allow for unlimited use and unrestricted exposure and will take more than five years to attain remedial action objectives and cleanup levels, a statutory review would be conducted within five years of initiation of remedial action for the Site to ensure that the remedy is, or will be, protective of human health and the environment.

14.0 Documentation of Significant Changes

The Proposed Plan for the Landia Site was released for public comment in June 2007. The public comment period ran from June 25, 2007 – July 25, 2007. The Proposed Plan identified Soil Alternative S2, excavation and off-site disposal of soils, and an interim action for the treatment of groundwater using chemical oxidation and in-situ bioremediation in the most contaminated areas as the Preferred Alternatives for soil and groundwater remediation. EPA reviewed all written and verbal comments submitted during the public comment period. It was determined that no significant changes to the remedy, as originally identified in the Proposed Plan, were necessary or appropriate.

APPENDIX A

Responsiveness Summary

APPENDIX A

Responsiveness Summary Landia Chemical Superfund Site Lakeland, Florida

The public comment period on the draft Proposed Plan for the Landia Chemical site was held from June 25, 2007 through July 25, 2007. A public meeting was held at the Lakeland Center on July 10, 2007, at 7:00 pm. The comments received during the public comment period are summarized below. This Responsiveness Summary addresses the comments received during the public comment period.

1. When will the Remedial Action begin?

EPA Response: After signature of the Record of Decision (ROD), EPA will negotiate with the Potentially Responsible Parties (PRPs) the terms under which the ROD will be implemented. After negotiations are complete, the design of the remedy will be conducted and then the remedy will be implemented. The soil excavation portion of the remedy will be conducted prior to implementation of the interim action for groundwater. The soil excavation is estimated to begin either the summer or fall of 2008.

2. Is the drinking water near the Site currently poisonous to the area residents?

EPA Response: No. Residents in the area near the Site are supplied municipal drinking water from the City of Lakeland which is pumped from deep wellfields, treated at the water treatment plant and regularly sampled. The nearest municipal well is more than a mile from the Site in the opposite direction of groundwater flow.

3. Which streets have the greatest concentrations of pesticides in the groundwater beneath them?

EPA Response: The groundwater from the Site flows to the north, west, and south. Generally speaking, contaminant concentrations are greatest on the Site property and decrease as groundwater moves away from the Site.

4. Is Lake Bonnet affected from the Site?

EPA Response: No. Current groundwater monitoring data indicate contamination has not migrated to Lake Bonnet. Groundwater monitoring will continue in order to ensure the extent of contamination is known.

5. What are the health effects that have been found?

EPA Response: The Florida Department of Health has conducted numerous health studies in the area including a Fish Tissue study from the Highland Street Pond in March 2000, a Public Health Assessment (June 27, 2000), an Exposure Investigation investigating the public health implications from eating pole beans and pinto beans grown from a garden on Wayman Street (August 10, 2000), and a study of selected cancer rates. While it is difficult to determine health effects from past exposures due to lack of analytical data, the studies did find that there was no apparent public health hazard for nearby residents.

6. Are the pipes that carry water to the neighborhood in contaminated soil? If so, and the pipes were to break, would contamination get into the drinking water?

EPA Response: Soil sampling shows very limited, if any contamination in the areas where water supply piping would be found. If pipes were to rupture in an area with soil contamination, it is very unlikely that any contamination would get into the drinking water. After broken pipes are repaired, water lines are flushed at the next hydrant to flush out any soil that may be in the pipes. It is important to note that all identified off-site soil contaminants are well below acute levels and are only present at low concentrations that are unacceptable only over long periods of time with consistent exposure.

7. There was a lawsuit in the past involving residents in the area. A lot of the residents didn't get paid. Is that going to take place again?

EPA Response: EPA has no authority or involvement in civil lawsuits between residents and private companies.

8. Is this the only area in Lakeland that is contaminated?

EPA Response: This is the only National Priorities List or "Superfund" site in Lakeland. However, there are other cleanup programs that address contaminated sites. EPA maintains a mapping and listing tool that shows sites where pollution is being or has been cleaned up throughout the United States called Cleanups in My Community. It maps, lists and provides cleanup progress profiles for sites, facilities and properties that have been contaminated by hazardous materials and are being, or have been, cleaned up under EPA's Superfund, RCRA and/or Brownfields cleanup programs. This tool is available on the Internet at <http://www.epa.gov/enviro/cleanups/>

9. What was the cutoff point when EPA stopped sampling?

EPA Response: The purpose of the Remedial Investigation was to determine the nature and extent of contamination in the soil, groundwater, sediment, and surface water. In order to accomplish this, screening criteria were used as a basis for deciding how far to sample. Samples were compared to the screening criteria which were generally the most stringent of all available, health based criteria (state and federal). Sampling occurred until detected concentrations were lower than the screening criteria. More specific information on screening criteria can be found in Section 7.1.1 Chemicals of Concern.

10. The Site should be returned to the same commercial state that it was when the cleanup was started. This means there should be proper drainage and the paved areas be replaced. The absence of someone on the property regularly encourages trespassing and vandalism.

EPA Response: EPA's primary responsibility is protection of human health and the environment. However, EPA encourages the reuse of contaminated properties and takes future use into consideration when designing and implementing a remedy. EPA agrees that it is beneficial to have someone regularly occupy the property. It is EPA's intent to require that any disturbed areas be restored to their previous conditions. It may be beneficial to replace the impermeable surfaces to minimize infiltration of rainwater which may slow groundwater contaminant migration. This will be further evaluated and decided during the remedial design. EPA cannot require enhancements to the property unless it is to meet an ARAR that is triggered by implementation of the remedy.

APPENDIX B

APPENDIX B

**STATEMENT OF WORK
FOR THE
REMEDIAL DESIGN AND REMEDIAL ACTION

AT THE

LANDIA CHEMICAL COMPANY SITE
LAKELAND, POLK COUNTY, FLORIDA**

I. INTRODUCTION

This Statement of Work (SOW) outlines the work to be performed by Settling Defendants at the Landia Chemical Company Site ("Site"). The work outlined is intended to fully implement the remedy as described in the Record of Decision (ROD) for the Site, dated September 27, 2007 and to achieve the Performance Standards set forth in the ROD, Consent Decree, and this SOW. The requirements of this SOW will be further detailed in work plans and other documents to be submitted by the Settling Defendants for approval as set forth in this SOW. It is not the intent of this document to provide task specific engineering or geological guidance. The definitions set forth in Section IV of the Consent Decree shall also apply to this SOW unless expressly provided otherwise herein.

Settling Defendants are responsible for performing the Work to implement the selected remedy. EPA shall conduct oversight of the Settling Defendants' activities throughout the performance of the Work. The Settling Defendants shall assist EPA in conducting oversight activities.

EPA review or approval of a task or deliverable shall not be construed as a guarantee as to the adequacy of such task or deliverable. If EPA modifies a deliverable pursuant to Section XXXI of the Consent Decree, such deliverable as modified shall be deemed approved by EPA for purposes of this SOW. A summary of the major deliverables that Settling Defendants shall submit for the Work is included at the end of this SOW.

II. OVERVIEW OF THE REMEDY

Operations at the Site resulted in the contamination of surface soil, subsurface soil and groundwater. The primary Contaminants of Concern (COCs) at the Site include pesticides, nitrates and some metals. As with many Superfund sites, the problems associated with the Landia Chemical Company site are complex. As a result, the Site was divided into two operable units in order to divide the work into manageable pieces. Operable Unit 1 (OU1) addresses the COCs present in soil and Operable Unit 2 (OU2) addresses the COCs present in the groundwater. The following Remedial Action Objectives (RAOs) were developed for this action to address all COCs in OU1 and provide an interim action for the COCs in OU2.

The objectives of this remedy are to:

OPERABLE UNIT 1 (Soil Contamination):

- Prevent direct contact with and/or ingestion of soil containing site-related COCs at concentrations above health-based action levels.
- Prevent or minimize future migration of COCs in soil to groundwater that would result in groundwater concentrations above drinking water standards.

OPERABLE UNIT 2 (Groundwater Contamination):

- Prevent direct contact and/or ingestion of groundwater containing site-related COCs at concentrations above drinking water standards.
- Prevent or minimize further migration of the contaminant plume by reducing the concentrations of site-related COCs in the areas of highest site-related groundwater concentrations above drinking water standards.

III. REMEDY

The remedy includes excavation and offsite disposal of contaminated soil in the industrial and residential areas, source treatment of contaminated groundwater, and monitoring of the effectiveness of the source treatment on areas with lower contaminant concentrations.

A. Components

The major components of the remedy are described in Section 12.0, Selected Remedy section of the attached Record of Decision.

B. Treatment

The treatment technologies for the remedy are described in Section 12.0, Selected Remedy section of the attached Record of Decision.

C. Performance Standards

Settling Defendants shall meet all Performance Standards, as defined in the Consent Decree including the standards set forth in the attached Record of Decision. In lieu of developing a separate Performance Standards Verification Plan, Settling Defendants shall include a section in the Remedial Design, which demonstrates how performance standards are to be met.

D. Compliance Testing

Settling Defendants shall perform compliance testing to ensure that all Performance Standards are met.

IV. PLANNING AND DELIVERABLES

The remedy is divided into two major and separate operable units. Operable Unit 1 (OU1) is the response action to remediate the soil contamination, and Operable Unit 2 (OU2) is the response action to remediate the contaminated groundwater. Unless otherwise directed by EPA, Settling Defendants shall perform the tasks described below separately for each Operable Unit.

The specific scope of this work shall be documented by Settling Defendants in a Remedial Design (RD) Work Plan and a Remedial Action (RA) Work Plan. Plans, specifications, submittals, and other deliverables shall be subject to EPA review and approval in accordance with Section XI of the Consent Decree.

Settling Defendants shall submit a technical memorandum documenting any need for additional data along with the proposed Data Quality Objectives (DQOs) whenever such requirements are identified. Settling Defendants are responsible for fulfilling additional data and analysis needs identified by EPA during the RD/RA process consistent with the general scope and objectives of the Consent Decree, including this SOW.

For each Operable Unit, Settling Defendants shall perform the following tasks:

TASK I - PROJECT PLANNING

The Settling Defendants shall meet with the EPA Remedial Project Manager (RPM) during the project planning phase to assist in developing a conceptual understanding of the RD/RA requirements for the Site. Information developed during this meeting shall be utilized to plan the project and to determine the extent of the additional data necessary to implement the RD/RA.

TASK II - REMEDIAL DESIGN

The Remedial Design shall provide the technical details for implementation of the Remedial Action in accordance with currently accepted environmental protection technologies and standard professional engineering and construction practices. The design shall include clear and comprehensive design plans and specifications.

A. Remedial Design Planning

The RD shall provide the technical details for implementation of the RA in accordance with currently accepted environmental protection technologies and standard professional engineering and construction practices. The RD shall include clear and comprehensive design plans and specifications.

1. Remedial Design Work Plan

Settling Defendants shall submit an RD Work Plan to EPA for review and approval. The existing Health and Safety Plan shall be updated as necessary for RD data collection activities and submitted to EPA for review and comment. EPA's review and/or approval of design submittals only allow Settling Defendants to proceed to the next step of the design

process. It does not imply acceptance of later design submittals that have not been reviewed, nor that the remedy, when constructed, will meet Performance Standards.

Specifically, the RD Work Plan should contain the following components:

- a. Comprehensive description of the additional data collection and evaluation activities to be performed, if any;
- b. List of the plans and specifications that will be prepared;
- c. A statement of the problem(s) and potential problem(s) posed by the Site and the objectives of the RD/RA.
- d. A background summary setting forth the following:
 - A brief description of the Site including the geographic location and the physiographic, hydrologic, geologic, demographic, ecological, and natural resource features;
 - A brief synopsis of the history of the Site, including a summary of past disposal practices and a description of previous responses that have been conducted by local, State, Federal, or private parties;
 - A summary of the existing data including physical and chemical characteristics of the contaminants identified and their distribution among the environmental media at the Site.
- e. A design management schedule that lists, in detail, the following:
 - A description of the tasks to be performed;
 - The information that is needed to perform each task;
 - The information that Settling Defendants will produce during and at the conclusion of each task;
 - A description of the work products that shall be submitted to EPA;
 - The specific dates for completion of each required task and/or the submission of each deliverable required by the Consent Decree and this SOW; and
 - Information regarding timing, initiation and completion of all critical path milestones for each task and/or deliverable. This description shall include the deliverables set forth in the remainder of Task II.
- f. A project management plan, which includes the following:
 - A data management plan, which shall address the requirements for project management systems, including tracking, sorting,

and retrieving the data along with an identification of the software to be used, minimum data requirements, data format and a backup process for the data management;

- A schedule for submitting quarterly reports to EPA; and
 - A plan for document control for all activities conducted during the RD/RA.
- g. A description of the community relations support that Settling Defendants will conduct during the RD. At EPA's request, Settling Defendants shall assist EPA in preparing and disseminating information to the public regarding the RD work to be performed.
2. Treatability Studies

Treatability studies may be required to determine the areas of groundwater to be treated via chemical oxidation and enhanced biodegradation. If it is determined at any time during the Remedial Design that a treatability study is necessary, Settling Defendants shall prepare a treatability study work plan and submit it to EPA for review and approval prior to commencing the treatability study. Once completed, the results of the treatability study shall be summarized either in a separate report and submitted to EPA for review and approval or included in the draft RD as discussed below.

3. Draft Remedial Design

In accordance with the design management schedule established in the approved RD Work plan, Settling Defendants shall prepare and submit to EPA the Draft Remedial Design. The technical requirements of the Remedial Action shall be addressed and outlined in the RD Work Plan so that they may be reviewed to determine if the final design will provide an effective remedy. Supporting data and documentation shall be provided with the design documents defining the functional aspects of the project.

In addition, the Draft Remedial Design shall consist of the following:

- a. Design Criteria: Detailed design concepts which support the technical aspects of the design. Specifically, the Design Criteria section shall include the design assumptions and parameters, including:
- Waste characterization;
 - Pretreatment requirements;
 - Volume of each media requiring treatment;
 - Treatment schemes (including all media and by-products);
 - Materials and equipment;

- Performance Standards; and
 - Long-term monitoring requirements.
- b. Plans and Specifications: Drawings or specifications which describe the design. This shall include, at a minimum:
- drawings which identify the areas of soil excavation both in the industrial and residential areas,
 - drawings which identify the areas proposed to be treated via chemical oxidation, and
 - drawing which identify the areas proposed to be treated via bioremediation,
- c. Treatability Study Results: The results of any treatability studies conducted during the RD shall be included in the draft RD.
- d. Plan for Implementing Institutional Controls: The Draft RD shall include a plan either discussing how the Institutional Controls (ICs) required in the ROD have already been implemented or a plan for how the required ICs will be implemented including a schedule for implementation.
- e. Groundwater Monitoring Plan (OU2 only): Settling Defendants shall update the existing groundwater monitoring Plan dated February 2006, to include any subsequently approved revisions and any additional monitoring requirements specific to the implementation of the interim action for OU2. The updated groundwater monitoring plan shall focus on determining the stability of the contaminant plume, evaluating the effectiveness of the implementation of the OU1 remedy and the interim actions for treating contaminant source areas, and evaluating the natural attenuation of contaminants away from the source area. The updated groundwater monitoring plan shall be submitted to EPA for review and approval. The most recent monitoring data shall be incorporated into the draft RD.
- f. Sampling and Analysis Plan (SAP) (OU1 only): Settling Defendants shall prepare a Sampling and Analysis Plan for the OU1 portion of the remedy to ensure that sample collection and analytical activities are conducted in accordance with technically acceptable protocols and that the data generated shall meet the DQOs established. The SAP shall include a Field Sampling and Analysis Plan (FSAP) and a Quality Assurance Project Plan (QAPP).

The FSAP shall define in detail the sampling and data-gathering methods that shall be used during implementation of the OU1 portion of the remedy. It shall include sampling objectives, sample location and frequency, sampling equipment and procedures, and sample handling and analysis. The FSAP shall be written so that a field sampling team unfamiliar with the Site would be able to gather the samples and field information required. The QAPP shall describe the

project objectives and organization, functional activities, and quality assurance and quality control (QA/QC) protocols that shall be used to achieve the desired DQOs. The DQOs shall, at a minimum, reflect use of analytical methods for obtaining data of sufficient quality to meet National Contingency Plan requirements as identified at 300.435 (b). In addition, the QAPP shall address personnel qualifications, sampling procedures, sample custody, analytical procedures, and data reduction, validation, and reporting. These procedures must be consistent with the Region IV Environmental Compliance Branch Standard Operating Procedures and Quality Assurance Manual and the guidance documents specified in Section VIII of the Consent Decree.

Prior to conducting any sampling activity, Settling Defendants shall demonstrate, to EPA's satisfaction, that each laboratory used is qualified to conduct the proposed work and meets the requirements specified in Section VIII of the Consent Decree. EPA may require Settling Defendants to submit detailed information to demonstrate that the laboratory is qualified to conduct the work, including information on personnel qualifications, equipment and material specification, and laboratory analyses of performance samples (blank and/or spike samples). In addition, EPA may require submittal of data packages equivalent to those generated by the EPA Contract Laboratory Program (CLP).

- g. Construction Schedule: Settling Defendants shall develop a Construction Schedule for constructing and implementing the remedial action, which identifies timing for initiation and completion of all critical path tasks. Settling Defendants shall specifically identify dates for completion of the project and major milestones.
- h. Construction Cost Estimate: An estimate within +15 percent to -10 percent of actual construction costs shall be submitted.

4. Final Remedial Design

In accordance with the design management schedule, and after receiving comments from EPA and the State, Settling Defendants shall submit a Final Remedial Design to EPA, which addresses comments generated from EPA's and the State's review of the Draft Remedial Design. In addition, at the time that Settling Defendants submit the Final Remedial Design, Settling Defendants shall submit a memorandum to EPA indicating how the comments received from EPA and the State on the Draft Design were incorporated into the Final Design. All Final Design documents shall be certified by a Professional Engineer registered in the State of Florida. EPA must provide written approval of the Final Design to Settling Defendants before Settling Defendants may initiate the RA, unless specifically authorized by EPA.

TASK III - REMEDIAL ACTION

Remedial Action shall be performed by Settling Defendants to implement the response actions selected in the ROD.

A. Remedial Action Planning

Within 30 days after EPA's approval of the Final Design, Settling Defendants shall submit a draft Remedial Action (RA) Work Plan, Project Delivery Strategy, a Construction Management Plan, a Construction Quality Assurance Plan, and a Construction Health and Safety Plan/Contingency Plan. The RA Work Plan, Project Delivery Strategy, Construction Management Plan, and Construction Quality Assurance Plan must be reviewed and approved by EPA and the Construction Health and Safety Plan/Contingency Plan reviewed by EPA prior to the initiation of the Remedial Action.

Upon approval of the Final Design and the RA Work Plan, Settling Defendants shall implement the RA Work Plan in accordance with the construction management schedule. Significant field changes to the RA as set forth in the RA Work Plan and Final Design shall not be undertaken without the approval of EPA. Deliverables shall be submitted to EPA for review and approval in accordance with Section XI of the Consent Decree. Review and/or approval of submittals does not imply acceptance of later submittals that have not been reviewed, nor that the remedy, when constructed, will meet Performance Standards.

1. RA Work Plan

A Work Plan which provides a detailed plan of action for completing the RA activities shall be submitted to EPA for review and approval. The objective of this work plan is to provide for the safe and efficient completion of the RA. The Work Plan shall be developed in conjunction with the Project Delivery Strategy, Construction Management Plan, the Construction Quality Assurance Plan, and the Construction Health and Safety Plan/Contingency Plan, although each plan may be delivered under separate cover. The Work Plan shall include a comprehensive description of the work to be performed and the Final Construction schedule for completion of each major activity and submission of each deliverable.

Specifically, the RA Work Plan shall present the following:

- a. A detailed description of the tasks to be performed and a description of the work products to be submitted to EPA. This includes the deliverables set forth in the remainder of Task III.
- b. A schedule for completion of each required activity and submission of each deliverable required by this Consent Decree, including those in this SOW.
- c. A project management plan, including provision for quarterly reports to EPA.
- d. A description of the community relations support to be conducted during the RA. At EPA's request, Settling Defendants shall assist EPA in preparing and disseminating information to the public regarding the RA work to be performed.

2. Project Delivery Strategy

Settling Defendants shall submit a document to EPA for review and approval describing the strategy for delivering the project. This document shall address the management approach for implementing the Remedial

Action, including procurement methods and contracting strategy, phasing alternatives, and contractor and equipment availability concerns. If the construction of the remedy is to be accomplished by Settling Defendants' "in-house" resources, the document shall identify those resources.

3. Construction Management Plan

A Construction Management Plan shall be developed to indicate how the construction activities are to be implemented and coordinated with EPA during the RA. Settling Defendants shall designate a person to be a Remedial Action Coordinator and its representative on-site during the Remedial Action, and identify this person in the Plan. This Plan shall also identify other key project management personnel and lines of authority, and provide descriptions of the duties of the key personnel along with an organizational chart. In addition, a plan for the administration of construction changes and EPA review and approval of those changes shall be included.

4. Construction Quality Assurance Plan

Settling Defendants shall develop and implement a Construction Quality Assurance Program to ensure, with a reasonable degree of certainty, that the completed Remedial Action meets or exceeds all design criteria, plans and specifications, and Performance Standards. The Construction Quality Assurance Plan shall incorporate relevant provisions of the Performance Standards Verification Plan (see Task V). At a minimum, the Construction Quality Assurance Plan shall include the following elements:

- a. A description of the quality control organization, including a chart showing lines of authority, identification of the members of the Independent Quality Assurance Team (IQAT), and acknowledgment that the IQAT will implement the control system for all aspects of the work specified and shall report to the project coordinator and EPA. The IQAT members shall be representatives from testing and inspection organizations and/or the Supervising Contractor and shall be responsible for the QA/QC of the Remedial Action. The members of the IQAT shall have a good professional and ethical reputation, previous experience in the type of QA/QC activities to be implemented and demonstrated capability to perform the required activities. They shall also be independent of the construction contractor.
- b. The name, qualifications, duties, authorities, and responsibilities of each person assigned a QC function.
- c. Description of the observations and control testing that will be used to monitor the construction and/or installation of the components of the Remedial Action. This includes information which certifies that personnel and laboratories performing the tests are qualified and the equipment and procedures to be used comply with applicable standards. Any laboratories to be used shall be specified. Acceptance/Rejection criteria and plans for implementing corrective measures shall be addressed.

- d. A schedule for managing submittals, testing, inspections, and any other QA function (including those of contractors, subcontractors, fabricators, suppliers, purchasing agents, etc.) that involve assuring quality workmanship, verifying compliance with the plans and specifications, or any other QC objectives. Inspections shall verify compliance with all environmental requirements and include, but not be limited to, air quality and emissions monitoring records and waste disposal records, etc.
- e. Reporting procedures and reporting format for QA/QC activities including such items as daily summary reports, schedule of data submissions, inspection data sheets, problem identification and corrective measures reports, evaluation reports, acceptance reports, and final documentation.
- f. A list of definable features of the work to be performed. A definable feature of work is a task which is separate and distinct from other tasks and has separate control requirements.

5. Construction Health and Safety Plan/Contingency Plan

Settling Defendants shall prepare a Construction Health and Safety Plan/Contingency Plan in conformance with Settling Defendants' health and safety program, and in compliance with OSHA regulations and protocols. The Construction Health and Safety Plan shall include a health and safety risk analysis, a description of monitoring and personal protective equipment, medical monitoring, and site control. EPA will not approve Settling Defendants' Construction Health and Safety Plan/Contingency Plan, but rather EPA will review it to ensure that all necessary elements are included, and that the plan provides for the protection of human health and the environment. This plan shall include a Contingency Plan and incorporate Air Monitoring and Spill Control and Countermeasures Plans. The Contingency Plan is to be written for the onsite construction workers and the local affected population. It shall include the following items:

- a. Name of person who will be responsible in the event of an emergency incident.
- b. Plan for initial site safety indoctrination and training for all employees, name of the person who will give the training and the topics to be covered.
- c. Plan and date for meeting with the local community, including local, state and federal agencies involved in the cleanup, as well as the local emergency squads and the local hospitals.
- d. A list of the first aid and medical facilities including, location of first aid kits, names of personnel trained in first aid, a clearly marked map with the route to the nearest medical facility, all necessary emergency phone numbers conspicuously posted at the job site (i.e., fire, rescue, local hazardous material teams, National Emergency Response Team, etc.)

- e. Plans for protection of public and visitors to the job site.
- f. Air Monitoring Plan which incorporates the following requirements:
 - 1. Air monitoring shall be conducted on Site and at the perimeter of the Site. Settling Defendants shall clearly identify the compounds and the detection and notification levels required in Paragraph 4 below. Air monitoring shall include personnel monitoring, on-site area monitoring, and perimeter monitoring.
 - 2. Personnel monitoring shall be conducted according to OSHA and NIOSH regulations and guidance.
 - 3. Onsite Area monitoring shall consist of continuous real-time monitoring performed immediately adjacent to any waste excavation areas, treatment areas, and any other applicable area when work is occurring. Measurements shall be taken in the breathing zones of personnel and immediately upwind and downwind of the work areas. Equipment shall include the following, at a minimum: organic vapor meter, explosion meter, particulate monitoring equipment, and onsite windsock.
 - 4. Perimeter monitoring shall consist of monitoring airborne contaminants at the perimeter of the Site to determine whether harmful concentrations of toxic constituents are migrating off-site. EPA approved methods shall be used for sampling and analysis of air at the Site perimeter. The results of the perimeter air monitoring and the on-site meteorological station shall be used to assess the potential for off-site exposure to toxic materials. The air monitoring program shall include provisions for notifying nearby residents, local, state and federal agencies in the event that unacceptable concentrations of airborne toxic constituents are migrating off-site. Settling Defendants shall report detection of unacceptable levels of airborne contaminants to EPA in accordance with Section X of the Consent Decree.
 - 5. Wipe sampling in certain apartments to ensure that contaminants are not being tracked in or brought in by dust.
- g. A Spill Control and Countermeasures Plan which shall include the following:
 - 1. Contingency measures for potential spills and discharges from materials handling and/or transportation.
 - 2. A description of the methods, means, and facilities required to prevent contamination of soil, water, atmosphere, and uncontaminated structures, equipment, or material by spills or discharges.

3. A description of the equipment and personnel necessary to perform emergency measures required to contain any spillage and to remove spilled materials and soils or liquids that become contaminated due to spillage. This collected spill material must be properly disposed of.
4. A description of the equipment and personnel to perform decontamination measures that may be required for previously uncontaminated structures, equipment, or material.

B. Preconstruction Conference

A Preconstruction Conference shall be held after selection of the construction contractor but before initiation of construction. This conference shall include Settling Defendants and federal, state and local government agencies and shall:

1. Define the roles, relationships, and responsibilities of all parties;
2. Review methods for documenting and reporting inspection data;
3. Review methods for distributing and storing documents and reports;
4. Review work area security and safety protocols;
5. Review the Construction Schedule;
6. Conduct a site reconnaissance to verify that the design criteria and the plans specifications are understood and to review material and equipment storage locations.

The Preconstruction Conference must be documented, including names of people in attendance, issues discussed, clarifications made, special instructions issued, etc.

C. Pre-final Construction Inspection

Upon preliminary project completion Settling Defendants shall notify EPA for the purpose of conducting a Pre-final Construction Inspection. Participants should include the Project Coordinators, Supervising Contractor, Construction Contractor, Natural Resource Trustees and other federal, state, and local agencies with a jurisdictional interest. The Pre-final Inspection shall consist of a walk-through inspection of the entire project site. The objective of the inspection is to determine whether the construction is complete and consistent with the Consent Decree. Any outstanding construction items discovered during the inspection shall be identified and noted on a punch list. Additionally, treatment equipment shall be operationally tested by Settling Defendants. Settling Defendants shall certify that the equipment has performed to effectively meet the purpose and intent of the specifications. Retesting shall be completed where deficiencies are revealed. A Pre-final Construction Inspection Report shall be submitted by Settling Defendants which outlines the outstanding construction items, actions required to resolve the items, completion date for the items, and an anticipated date for the Final Inspection.

D. Final Construction Inspection

Upon completion of all outstanding construction items, Settling Defendants shall notify EPA for the purpose of conducting a Final Construction Inspection. The Final Construction Inspection shall consist of a walk-through inspection of the entire project site. The Pre-final Construction Inspection Report shall be used as a check list with the Final Construction Inspection focusing on the outstanding construction items identified in the Pre-final Construction Inspection. All tests that were originally unsatisfactory shall be conducted again. Confirmation shall be made during the Final Construction Inspection that all outstanding items have been resolved. Any outstanding construction items discovered during the inspection still requiring correction shall be identified and noted on a punch list. If any items are still unresolved, the inspection shall be considered to be a Pre-final Construction Inspection requiring another Prefinal Construction Inspection Report and subsequent Final Construction Inspection.

E. Final Construction Report

Within thirty (30) days following the conclusion of the Final Construction Inspection, Settling Defendants shall submit a Final Construction Report. EPA will review the draft report and will provide comments to Settling Defendants. The Final Construction Report shall include the following:

1. Brief description of how outstanding items noted in the Pre-final Inspection were resolved;
2. Explanation of modifications made during the RA to the original RD and RA Work Plans and why these changes were made;
3. Synopsis of the construction work defined in the SOW and certification that the construction work has been completed.

F. Remedial Action Report

As provided in Section XIV of the Consent Decree, within 90 days after Settling Defendants conclude that the Remedial Action has been fully performed and the Performance Standards have been attained, Settling Defendants shall so certify to the United States and shall schedule and conduct a pre-certification inspection to be attended by EPA and Settling Defendants. If after the pre-certification inspection Settling Defendants still believe that the Remedial Action has been fully performed and the Performance Standards have been attained, Settling Defendants shall submit a Remedial Action (RA) Report to EPA in accordance with Section XIV of the Consent Decree. The RA Report shall include the following:

1. A copy of the Final Construction Report;
2. Synopsis of the work defined in this SOW and a demonstration in accordance with the Performance Standards Verification Plan that Performance Standards have been achieved; and
3. Certification that the Remedial Action has been completed in full satisfaction of the requirements of the Consent Decree.

After EPA review, Settling Defendants shall address any comments and submit a revised report. As provided in Section XIV of the Consent Decree, the Remedial Action shall not be considered complete until EPA approves the RA Report.

TASK IV - OPERATION AND MAINTENANCE

After implementation of OU1 of the remedy, no active remediation systems will be operated for OU1. Operation and Maintenance relating to OU2 shall be addressed in the final ROD for OU2. Therefore, an Operation and Maintenance Plan is not necessary for this action.

TASK V - PERFORMANCE MONITORING

Performance monitoring shall be conducted to ensure that all Performance Standards are met.

A. Performance Standards Verification Plan

The purpose of the Performance Standards Verification Plan is to provide a mechanism to ensure that both short-term and long-term Performance Standards for the Remedial Action are met. Settling Defendants shall submit a Performance Standards Verification Plan with the Draft Design. Once approved, Settling Defendants shall implement the Performance Standards Verification Plan on the approved schedule. The Performance Standards Verification Plan shall include:

1. A Performance Standards Verification Field Sampling and Analysis Plan that provides guidance for all fieldwork by defining in detail the sampling and data gathering methods to be used.
2. A Performance Standards Verification Quality Assurance/Quality Control plan that describes the quality assurance and quality control protocols which will be followed in demonstrating compliance with Performance standards.
3. A specification of those tasks to be performed by Settling Defendants to demonstrate compliance with the Performance Standards and a schedule for the performance of these tasks.

REFERENCES

The following list, although not comprehensive, comprises many of the regulations and guidance documents that apply to the RD/RA process. Settling Defendants shall review these guidance documents and shall use the information provided therein in performing the RD/RA and preparing all deliverables under this SOW.

1. "National Oil and Hazardous Substances Pollution Contingency Plan, Final Rule", Federal Register 40 CFR Part 300, March 8, 1990.
2. "Superfund Remedial Design and Remedial Action Guidance," U.S. EPA, Office of Emergency and Remedial Response, June 1986, OSWER Directive No. 9355.O-4A.
3. "Interim Final Guidance on Oversight of Remedial Designs and Remedial Actions Performed by Potentially Responsible Parties," U.S. EPA, Office of Emergency and Remedial Response, February 14, 1990, OSWER Directive No. 9355.5-01.
4. "Guidance for Conducting Remedial Investigations and Feasibility Studies Under CERCLA, Interim Final," U.S. EPA, Office of Emergency and Remedial Response, October 1988, OSWER Directive No. 355.3-01.
5. "A Compendium of Superfund Field Operations Methods," Two Volumes, U.S. EPA, Office of Emergency and Remedial Response, EPA/540/P-87/001a, August 1987, OSWER Directive No. 9355.0-14.
6. "EPA NEIC Policies and Procedures Manual," EPA-330/9-78-001-R, May 1978, revised November 1984.
7. "Data Quality Objectives for Remedial Response Activities," U.S. EPA, Office of Emergency and Remedial Response and Office of Waste Programs Enforcement, EPA/540/G-87/003, March 1987, OSWER Directive No. 9335.0-7B.
8. "Guidelines and Specifications for Preparing Quality Assurance Project Plans," U.S. EPA, Office of Research and Development, Cincinnati, OH, QAMS-004/80, December 29, 1980.
9. "Interim Guidelines and Specifications for Preparing Quality Assurance Project Plans," U.S. EPA, Office of Emergency and Remedial Response, QAMS-005/80, December 1980.
10. "Users Guide to the EPA Contract Laboratory Program," U.S. EPA, Sample Management Office, August 1982.
11. "Environmental Compliance Branch Standard Operating Procedures and Quality Assurance Manual," U.S. EPA Region IV, Environmental Services Division, February 1, 1991, (revised periodically).
12. "USEPA Contract Laboratory Program Statement of Work for Organics Analysis," U.S. EPA, Office of Emergency and Remedial Response, February 1988.

13. "USEPA Contract Laboratory Program Statement of Work for Inorganics Analysis," U.S. EPA, Office of Emergency and Remedial Response, July 1988.
14. "Quality in the Constructed Project: A Guideline for Owners, Designers, and Constructors, Volume 1, Preliminary Edition for Trial Use and Comment," American Society of Civil Engineers, May 1988.
15. "Interim Guidance on Compliance with Applicable or Relevant and Appropriate Requirements," U.S. EPA, Office of Emergency and Remedial Response, July 9, 1987, OSWER Directive No. 9234.0-05.
16. "CERCLA Compliance with Other Laws Manual," Two Volumes, U.S. EPA, Office of Emergency and Remedial Response, August 1988 (Draft), OSWER Directive No. 9234.1-01 and -02.
17. "Guidance on Remedial Actions for Contaminated Ground Water at Superfund Sites," U.S. EPA, Office of Emergency and Remedial Response, (Draft), OSWER Directive No. 9283.1-2.
18. "Guide for Conducting Treatability Studies Under CERCLA," U.S. EPA, Office of Emergency and Remedial Response, Pre-publication Version.
19. "Health and Safety Requirements of Employees Employed in Field Activities," U.S. EPA, Office of Emergency and Remedial Response, July 12, 1981, EPA Order No. 1440.2.
20. "Standard Operating Safety Guides," U.S. EPA, Office of Emergency and Remedial Response, November 1984.
21. "Standards for General Industry," 29 CFR Part 1910, Occupational Health and Safety Administration.
22. "Standards for the Construction Industry," 29 CFR 1926, Occupational Health and Safety Administration.
23. "NIOSH Manual of Analytical Methods," 2d edition. Volumes I - VII, or the 3rd edition, Volumes I and II, National Institute of Occupational Safety and Health.
24. "Occupational Safety and Health Guidance Manual for Hazardous Waste Site Activities," National Institute of Occupational Safety and Health/Occupational Health and Safety Administration/United States Coast Guard/ Environmental Protection Agency, October 1985.
25. "TLVs - Threshold Limit Values and Biological Exposure Indices for 1987 - 88," American Conference of Governmental Industrial Hygienists.
26. "American National Standards Practices for Respiratory Protection," American National Standards Institute Z88.2-1980, March 11, 1981.
27. "Quality in the Constructed Project - Volume 1," American Society of Civil Engineers, 1990.

**SUMMARY OF THE MAJOR DELIVERABLES FOR THE
REMEDIAL DESIGN AND REMEDIAL ACTION AT
THE LANDIA CHEMICAL COMPANY**

DELIVERABLE FOR EACH OPERABLE UNIT

EPA RESPONSE

TASK I: PROJECT PLANNING

No deliverables planned as part of Task I.

TASK II: REMEDIAL DESIGN

RD Work Plan (5)	Review and Approve
Health and Safety Plan (2)	Review and Comment
Treatability Study Work Plan (OU2)	Review and Provide Comments
Treatability Study Report (OU2)	Review and Approve
Draft Design (5)	Review and Provide Comments
Groundwater Monitoring Plan (OU2) (5)	Review and Provide Comments
Sampling and Analysis Plan (OU1) (5)	Review and Approve
Final Design (5)	Review and Approve

TASK III: REMEDIAL ACTION

RA Work Plan (5)	Review and Approve
Project Delivery Strategy (5)	Review and Approve
Construction Management Plan (5)	Review and Approve
Construction Quality Assurance Plan (5)	Review and Approve
Construction Health and Safety Plan/Contingency Plan (5)	Review and Comment
Air Monitoring Plan (OU1) (5)	Review and Approve
Spill Control and Countermeasures Plan (5)	Review and Approve
Pre-final Construction Inspection Report (5)	Review and Approve
Final Construction Report (5)	Review and Approve
Remedial Action Report (5)	Review and Approve

TASK IV: OPERATION AND MAINTENANCE

No deliverables planned as part of Task IV.

TASK V: MONITORING

Performance Standards Verification Plan (5) Review and Approve

NOTE: *The number in parentheses indicates the number of copies to be submitted by Respondents. One copy shall be unbound, the remainder shall be bound.*

APPENDIX C

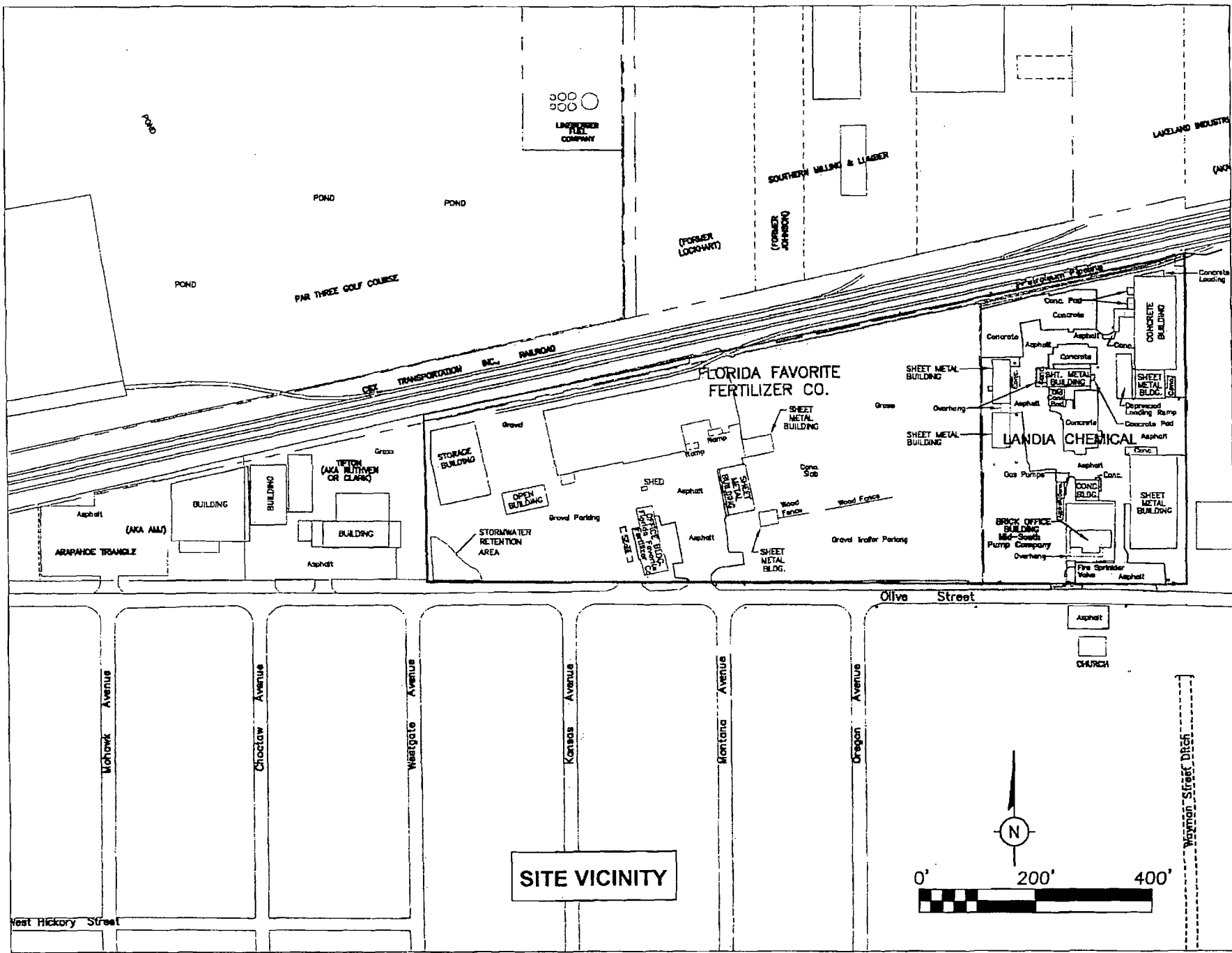

Landia Chemical Company Site Map

APPENDIX D

This instrument prepared by:
[Current Property Owner: name and address]

DECLARATION OF RESTRICTIVE COVENANTS

This Declaration of Restrictive Covenants (Declaration) is given this ____ day of _____, 2009, by _____, a Florida corporation, (Grantor), having an address of 1405 West Olive Street, Lakeland, Polk County, Florida to the State of Florida Department of Environmental Protection (FDEP or Grantee).

RECITALS

- A. **WHEREAS**, Grantor is the fee simple owner of a parcel of land situated in the county of Polk County, State of Florida, more particularly described in Exhibit "A" attached hereto and made a part hereof (the Property);
- B. **WHEREAS**, The Property subject to this restrictive covenant is a portion of the property known as the Landia Chemical Company Site (Site), which the U.S. Environmental Protection Agency (EPA), pursuant to Section 105 of the Comprehensive Environmental Response, Compensation and Liability Act (CERCLA), 42 U.S.C. § 9605, proposed for the National Priorities List, set forth at 40 C.F.R. Part 300, Appendix B, by publication in the Federal Register on May 11, 2000, at 65 Fed. Reg. 30482.
- C. **WHEREAS**, in a Record of Decision dated September 27, 2007 (ROD), the EPA Region 4 Regional Administrator selected a "remedial action" for the Site.
- D. **WHEREAS**, a remedial action selected pursuant to the EPA ROD will be performed on the Site.
- E. **WHEREAS**, contaminants in excess of allowable concentrations for unrestricted use will remain at the Property after completion of the remedial action.
- F. **WHEREAS**, it is the intent of the restrictions in this declaration to reduce or eliminate the risk of exposure of the contaminants to the environment and to users or occupants of the property and to reduce or eliminate the threat of migration of the contaminants.
- G. **WHEREAS**, it is the intention of all parties that EPA is a third party beneficiary of said restrictions and said restrictions shall be enforceable by the EPA, FDEP, and their successor agencies.
- H. **WHEREAS**, the parties hereto have agreed 1) to impose on the Property use restrictions as covenants that will run with the land for the purpose of protecting human health and the environment; and 2) to grant an irrevocable right of access over the Property to the

Grantee and its agents or representatives for purposes of implementing, facilitating and monitoring the remedial action; and

- I. **WHEREAS**, Grantor deems its desirable and in the best interest of all present and future owners of the Property that the Property be held subject to certain restrictions and changes, that will run with the land, for the purpose of protecting human health and the environment, all of which are more particularly hereinafter set forth.

NOW THEREFORE, Grantor, on behalf of itself, its successors, its heirs, and assigns, in consideration of the recitals above, the terms of the Record of Decision, and other good and valuable consideration, the adequacy and receipt of which is hereby acknowledged, does hereby covenant and declare that the Property shall be subject to the restrictions on use set forth below, which shall touch and concern and run with the title of the property, and does give, grant and convey to the Grantee, and its assigns, with general warranties of title, 1) an irrevocable use restriction and site access covenant of the nature and character, and for the purposes hereinafter set forth and 2), the perpetual right to enforce said covenants and use restrictions, with respect to the Property. Grantor further agrees as follows:

- a. The foregoing recitals are true and correct and are incorporated herein by reference.
- b. Grantor hereby imposes on the Property the following restrictions:
 1. **Restrictions on use:** The following covenants, conditions, and restrictions apply to the use of the Property:
 - a. Restrict the use of contaminated groundwater until drinking water standards are met. Detections of site-related contaminants are present in groundwater of the surficial aquifer both on-site and off-site at levels above drinking water standards.
 - b. Limit the future use of the Property to industrial. The cleanup goals for soil on the Property was developed assuming the use of the Property remains industrial.
 - c. Protect the integrity of on-site engineering controls. Certain structures including buildings, concrete slabs, and pavement on the Property currently prevents exposure to contaminated soil underneath.
 2. **Irrevocable Covenant for Site Access:** Grantor hereby grants to the Grantee, its agents and representatives, an irrevocable, permanent and continuing right of access at all reasonable times to the Property for purposes of:
 - a) Implementing the response actions in the ROD;
 - b) Verifying any data or information submitted to EPA and Grantee;

- c) Verifying that no action is being taken on the Property in violation of the terms of this instrument or of any federal or state environmental laws or regulations;
 - d) Monitoring response actions on the Site and conducting investigations relating to contamination on or near the Site, including, without limitation, sampling of air, water, sediments, soils, and specifically, without limitation, obtaining split or duplicate samples;
 - e) Conducting periodic reviews of the remedial action, including but not limited to, reviews required by applicable statutes and/or regulations; and
 - f) Implementing additional or new response actions if EPA determines i) that such actions are necessary to protect the environment because either the original remedial action has proven to be ineffective or because new technology has been developed which will accomplish the purposes of the remedial action in a significantly more efficient or cost effective manner; and, ii) that the additional or new response actions will not impose any significantly greater burden on the Property or unduly interfere with the then existing uses of the Property.
3. **Modification:** This Declaration shall not be modified, amended, or terminated without the written consent of FDEP or its successor agency. FDEP shall not consent to any such modification, amendment or termination without the written consent of EPA.
4. (a) **Reserved rights of Grantor:** Grantor hereby reserves unto itself, its successors, its heirs, and assigns, all rights and privileges in and to the use of the Property which are not incompatible with the restrictions, rights and covenants granted herein.
- (b) **Reserved Rights of EPA:** Nothing in this document shall limit or otherwise affect EPA's rights of entry and access or EPA's or authority to take response actions under CERCLA, the NCP, or other federal law.
- (c) **Reserved Rights of Grantee:** Nothing in this document shall limit or otherwise affect Grantee's rights of entry and access or authority to act under state or federal law.
5. **Notice requirement:** Grantor agrees to include in any instrument conveying any interest in any portion of the Property, including but not limited to deeds, leases and mortgages, a notice which is in substantially the following form:

**NOTICE: THE INTEREST CONVEYED HEREBY IS
 SUBJECT TO A DECLARATION OF RESTRICTIVE AND
 AFFIRMATIVE COVENANTS, DATED _____, 200__,
 RECORDED IN THE PUBLIC LAND RECORDS ON
 _____, 20__, IN BOOK _____, PAGE _____, IN
 FAVOR OF, AND ENFORCEABLE BY, THE STATE OF**

**FLORIDA DEPARTMENT OF ENVIRONMENTAL
PROTECTION.**

Within thirty (30) days of the date any such instrument of conveyance is executed, Grantor must provide Grantee and EPA with a certified true copy of said instrument and, if it has been recorded in the public land records, its recording reference.

6. **Enforcement:** The Grantee shall be entitled to enforce the terms of this instrument by resort to specific performance or legal process. All remedies available hereunder shall be in addition to any and all other remedies at law or in equity, including CERCLA. Enforcement of the terms of this instrument shall be at the discretion of the Grantee, and any forbearance, delay or omission to exercise its rights under this instrument in the event of a breach of any term of this instrument shall not be deemed to be a waiver by the Grantee of such term or of any subsequent breach of the same or any other term, or of any of the rights of the Grantee under this instrument. It is expressly agreed that EPA is not the recipient of a real property interest but is a third party beneficiary of the Declaration of Restrictive Covenants, and as such, has the right of enforcement.
7. **Damages:** Grantee shall be entitled to recover damages for violations of the terms of this instrument, or for any injury to the remedial action, to the public or to the environment protected by this instrument.
8. **Waiver of certain defenses:** Grantor hereby waives any defense of laches, estoppel, or prescription.
9. **Covenants:** Grantor hereby covenants to and with the Grantee, that the Grantor is lawfully seized in fee simple of the Property, that the Grantor has a good and lawful right and power to sell and convey it or any interest therein, that the Property is free and clear of encumbrances, except those noted on Exhibit B attached hereto, and that the Grantor will forever warrant and defend the title thereto and the quiet possession thereof.
10. **Notices:** Any notice, demand, request, consent, approval, or communication that either party desires or is required to give to the other shall be in writing and shall either be served personally or sent by first class mail, postage prepaid, referencing the Site name and Site ID number and addressed as follows:

To Grantor:

To Grantee:

Bureau Chief, Waste Cleanup
FDEP M.S. 4505
2600 Blair Stone Road
Tallahassee, FL 32399

To EPA:

U.S. EPA, Region 4
Waste Management Division
Superfund Remedial and Technical Services Branch
Section Chief, Section D
61 Forsyth Street, SW
Atlanta, GA 30303

11. **Recording in Land Records:** Grantor shall record this Declaration of Restrictive and Affirmative Covenants in timely fashion in the Official Records of Polk County, Florida, and shall rerecord it at any time Grantee may require to preserve its rights. Grantor shall pay all recording costs and taxes necessary to record this document in the public records.

12. **General provisions:**

a) **Controlling law:** The interpretation and performance of this instrument shall be governed by the laws of the United States or, if there are no applicable federal laws, by the law of the state where the Property is located.

b) **Liberal construction:** Any general rule of construction to the contrary notwithstanding, this instrument shall be liberally construed in favor of the grant to effect the purpose of this instrument and the policy and purpose of CERCLA. If any provision of this instrument is found to be ambiguous, an interpretation consistent with the purpose of this instrument that would render the provision valid shall be favored over any interpretation that would render it invalid.

c) **Severability:** If any provision of this instrument, or the application of it to any person or circumstance, is found to be invalid, the remainder of the provisions of this instrument, or the application of such provisions to persons or circumstances other than those to which it is found to be invalid, as the case may be, shall not be affected thereby.

d) **Entire Agreement:** This instrument sets forth the entire agreement of the parties with respect to rights and restrictions created hereby, and supersedes all prior discussions, negotiations, understandings, or agreements relating thereto, all of which are merged herein.

e) **No Forfeiture:** Nothing contained herein will result in a forfeiture or reversion of Grantor's title in any respect.

f) **Joint Obligation:** If there are two or more parties identified as Grantor herein, the obligations imposed by this instrument upon them shall be joint and several.

g) **Successors:** The term "Grantor", wherever used herein, and any pronouns used in place thereof, shall include the persons and/or entities named at the beginning of this document,

identified as "Grantor" and their personal representatives, heirs, successors, and assigns. The term "Grantee", wherever used herein, and any pronouns used in place thereof, shall include the persons and/or entities named at the beginning of this document, identified as "Grantee" and their personal representatives, heirs, successors, and assigns including any successor state agency to FDEP having administrative jurisdiction over the interests acquired by the State of Florida under this instrument. The rights of the Grantee and Grantor under this instrument are freely assignable, subject to the notice provisions hereof.

h) Termination of Rights and Obligations: A party's rights and obligations under this instrument terminate upon transfer of the party's interest in the Property, except that liability for acts or omissions occurring prior to transfer shall survive transfer.

i) Captions: The captions in this instrument have been inserted solely for convenience of reference and are not a part of this instrument and shall have no effect upon construction or interpretation.

j) Counterparts: The parties may execute this instrument in two or more counterparts, which shall, in the aggregate, be signed by both parties; each counterpart shall be deemed an original instrument as against any party who has signed it. In the event of any disparity between the counterparts produced, the recorded counterpart shall be controlling.

TO HAVE AND TO HOLD unto the State of Florida Department of Environmental Protection and its successors and assigns forever.

IN WITNESS WHEREOF, Grantor has caused this Agreement to be signed in its name.

Executed this _____ day of _____, 200_____

GRANTOR: _____
[Name and Title]

Signed, sealed and delivered in the presence of:

Witness: _____ Print Name _____ Date _____

Witness: _____ Print Name _____ Date _____

STATE OF FLORIDA
COUNTY OF _____

On this ___ day of _____, 200_, before me, the undersigned, a Notary Public in and for the State of Florida, duly commissioned and sworn, personally appeared _____, known to be the _____ of _____, the corporation that executed the foregoing instrument, and acknowledged the said instrument to be the free and voluntary act and deed of said corporation, for the uses and purposes therein mentioned, and on oath stated that they are authorized to execute said instrument.

Witness my hand and official seal hereto affixed the day and year written above.

Notary Public in and for the
State of Florida

My Commission Expires: _____

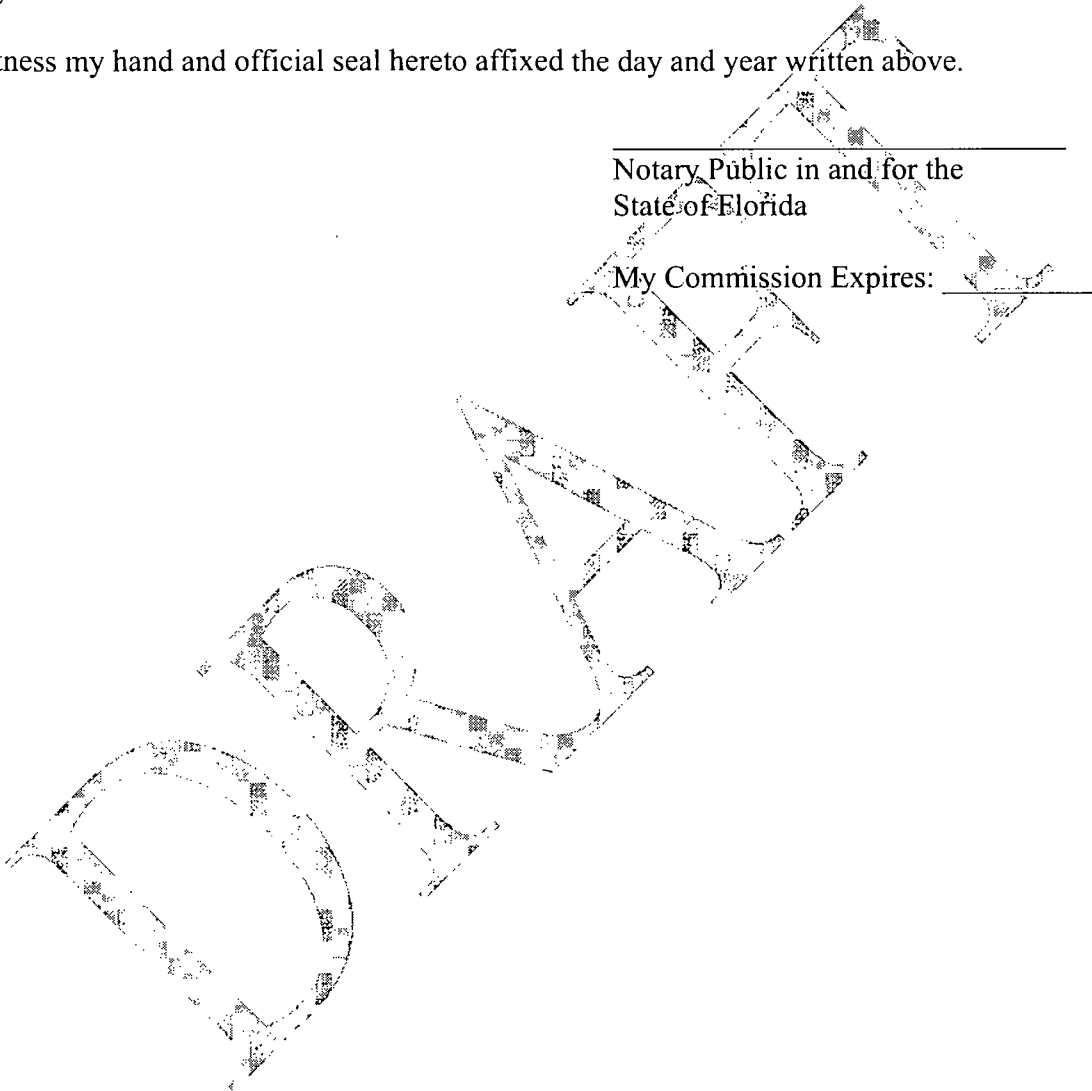

Approved as to form by the Florida Department of Environmental Protection, Office of general Counsel.

Assistant General Counsel

**STATE OF FLORIDA DEPARTMENT
OF ENVIRONMENTAL PROTECTION**

By: _____

Signed, sealed and delivered in the presence of:

Witness: _____ Print Name _____ Date _____

Witness: _____ Print Name _____ Date _____

**STATE OF FLORIDA
COUNTY OF _____**

On this ___ day of _____, 200_, before me, the undersigned, a Notary Public in and for the State of Florida, duly commissioned and sworn, personally appeared _____, known to be the Secretary of the Florida Department of Environmental Protection, the State Agency that executed the foregoing instrument, and acknowledged the said instrument to be the free and voluntary act and deed of said corporation, for the uses and purposes therein mentioned, and on oath stated that they are authorized to execute said instrument.

Witness my hand and official seal hereto affixed the day and year written above.

Notary Public in and for the
State of Florida

My Commission Expires: _____.

- Attachments: Exhibit A - Legal Description of the Property
- Exhibit B - Existing Liens and Encumbrances on the Property

APPENDIX E

MEMORANDUM OF AGREEMENT
Between
the U.S. Environmental Protection Agency, Region 4, Superfund Division and
the Southwest Florida Water Management District

This MEMORANDUM OF AGREEMENT (MOA) is hereby made and entered into by and between the United States Environmental Protection Agency (EPA) and the Southwest Florida Water Management District (SWFWMD). The purpose of this MOA is to develop a framework for cooperation between the EPA and the SWFWMD and to set forth the mutual understanding of the parties concerning cooperative efforts to minimize the potential effects of groundwater contamination in areas within SWFWMD's jurisdiction that are impacted or potentially impacted by Superfund sites, including procedures for information sharing and assisting in the implementation of certain institutional controls through the application of regulatory practices within SWFWMD's jurisdiction, to prevent the potential human exposure to contaminated groundwater in areas impacted or potentially impacted by Superfund sites.

Whereas, pursuant to the authority of the Comprehensive Environmental Response, Compensation, and Liability Act (CERCLA), as amended, 42 U.S.C. § 9601 et seq., and the National Contingency Plan, 40 CFR 300 et seq., EPA has the authority to conduct response actions at Superfund sites within the State of Florida;

Whereas, institutional controls are frequently used by EPA as part of selected response actions at Superfund sites;

Whereas, EPA policy defines institutional controls as non-engineering instruments such as administrative or legal controls that eliminate or minimize the potential of human exposure to contaminants and chemicals of concern and that protect the integrity of the remedy by limiting land or resource utilization. Institutional controls at a particular Superfund site may be selected

as a part of a removal or remedial action. Institutional controls selected as a part of a remedial action are identified in the Record of Decision (ROD) and may be more specifically established during the Remedial Design. At many Superfund sites, institutional controls are used to eliminate potential human exposure to contaminated groundwater beneath the Superfund site property and other adjacent or nearby properties;

Whereas, a groundwater institutional control may be a restriction on the construction of potable and irrigation wells and the use of contaminated groundwater within an area impacted by a Superfund site. Implementation and enforcement of institutional controls for contaminated groundwater may require the assistance of regulatory authorities such as the SWFWMD and various local government authorities;

Whereas, SWFWMD has adopted rules to govern the construction of water wells within the geographic boundaries of SWFWMD, to implement the provisions of Part III of Chapter 373, F.S.;

Whereas, such rules are adopted by SWFWMD to ensure that water wells within SWFWMD are located, constructed, maintained, used and abandoned in a manner that protects the water resources, does not pose a threat of contamination to the water resource and protects the health, safety and welfare of the public;

Whereas, SWFWMD has also adopted by reference and implements regulations promulgated by the Florida Department of Environmental Protection governing the construction of water wells, including the construction of water wells within delineated areas of contamination, as set forth in Chapters 62-532 and 62-524, F.A.C.;

Whereas, within the geographic boundaries of SWFWMD, unless otherwise exempt, a permit must be obtained prior to the construction, repair, modification or abandonment of a water well, including wells within areas delineated pursuant to Chapter 62-524, F.A.C., which encompass areas within which groundwater contamination may exist or is known to exist;

Whereas, pursuant to Chapter 40D-3, F.A.C., SWFWMD is authorized to impose upon any well construction permit issued by SWFWMD such reasonable conditions as are necessary to protect the water resource and assure that the permitted activity is consistent with the overall objectives of SWFWMD, and may deny an application for a well construction permit if construction or use of the well would increase the potential for harm to the public health, safety and welfare or if the proposed well would degrade groundwater quality by causing pollutants to spread;

Whereas, EPA and the SWFWMD desire to cooperate in exercising their respective regulatory authority to prevent the potential spread of groundwater contamination, protect aquifer water quality and promote public health, safety and welfare; and

Whereas, the Clean Water Act § 104(a) and (b), 33 U.S.C. 1254(a) and (b), provides EPA the authority to cooperate with organizations such as SWFWMD on strategies to address water pollution, including groundwater and surface water pollution.

IT IS MUTUALLY UNDERSTOOD AND AGREED BY AND BETWEEN THE PARTIES THAT:

A. As to EPA:

1. EPA shall notify SWFWMD in writing of any area of groundwater impacted by a Superfund site within the jurisdiction of SWFWMD.

2. Attached hereto and incorporated herein by reference as Appendix 1 is a list of agreed-upon Superfund sites within the jurisdiction of SWFWMD to which this MOA shall be applicable and which shall hereinafter be referred to as the Superfund Areas. EPA shall provide SWFWMD with a written description, aerial depiction and electronic data in a format compatible with the District's Geographic Information System showing the extent of the known and potential groundwater contamination for each of the Superfund Areas contained in Appendix 1. Electronic data should be provided in a shapefile that is in State Plane Feet West Zone, North American Datum of 1983 HARN, with units in feet and vertical units in feet, NAVD 88. Geometry should be polygon, if applicable. Attributes will need column descriptions and domains, and metadata should be FGCD compliant. EPA shall periodically provide an updated written description, aerial depiction and electronic data to SWFWMD for each Superfund Area as often as necessary to maintain an accurate boundary of the Superfund Area, or at least every five years.
3. EPA shall consult with SWFWMD to establish an inner and outer boundary of the area of groundwater impacted or potentially impacted by a Superfund Area. The inner boundary shall be known as the contamination zone or Zone A. The area between the inner and outer boundary shall be known as the buffer zone or Zone B.
4. For each Superfund Area, consistent with EPA's policies on conducting Five-Year Reviews, EPA will ensure a well survey is conducted at least every five years within Zones A and B or the area of the extent of groundwater contamination if greater. The well survey will be conducted through field inspection and will identify any new wells

constructed or operating since the last review was conducted. EPA shall also provide to SWFWMD available monitoring and other site assessment reports demonstrating the status of groundwater contamination.

5. EPA agrees that if any portion of a Superfund Area appended, or proposed to be appended, to this MOA is situated within an area delineated as an area of groundwater contamination pursuant to Section 373.309(1)(e), F.S., EPA will incorporate in its institutional controls for such Superfund Area provisions for complying with the regulations promulgated in Chapter 62-524, F.A.C., if applicable.

B. As to SWFWMD:

1. Upon receipt of the electronic and other descriptive data for a Superfund Area including the contamination zone and buffer zone for such Superfund Area, SWFWMD will make available through its website for public information purposes an aerial map depicting the location of the Superfund Area and specifically the contamination zone and buffer zone for each Superfund Area. A written description of the Superfund Area will also be made available to the public upon request.
2. When reviewing and approving permit applications involving activity to be undertaken on property located within a Superfund Area (hereinafter referred to as a Permit Application), SWFWMD will, where appropriate, impose such reasonable conditions as are necessary to protect the water resource, prevent the spread of ground or surface water contamination and otherwise be consistent with the overall objectives of SWFWMD. For well construction permits, such conditions may include prohibiting use of the well as a

potable water supply, requiring notice to well owners of potential groundwater contamination or requiring specific methods of construction.

3. SWFWMD agrees that following receipt of an application for a well construction permit for activity located within Zone A of a Superfund Area, if a Request for Additional Information (RAI) is issued, SWFWMD will provide to EPA a copy of the RAI.
4. Pursuant to Rule 40D-3.505(3), F.A.C., SWFWMD will deny an application for a well construction permit for activity in Zone A of a Superfund Area if use of the well would increase the potential for harm to public health, safety and welfare, or if the proposed well would degrade the water quality of the aquifer by causing pollutants to spread.
5. SWFWMD will provide notice to EPA of the receipt of a written request for a variance or waiver pursuant to Section 120.542, F.S., Rule 40D-1.1001, F.A.C., or Rule 40D-3.505(4), F.A.C., or an objection or petition for a hearing in relation to a Permit Application for an activity located or to be located within a Superfund Area.

C. As to both parties:

1. Both parties agree to make their staffs available for timely consultation as to the potential for groundwater impacts occurring within or near a Superfund Area as a result of proposed activity for which a Permit Application is received by SWFWMD.
2. This MOA may be amended in writing upon mutual consent as the parties deem necessary, and such amendments shall take effect upon execution by both parties.
3. Additions or deletions to the list of Superfund Areas contained in Appendix 1 hereto may be made at any time upon mutual consent of the parties.

4. Each party hereby designates the position set forth below as its contact person who shall be responsible for receiving all notices as described herein and for assisting with coordination and overall implementation of this MOA for the respective agency:

For EPA: Division Director
 U.S. Environmental Protection Agency
 Region IV, Superfund Division
 61 Forsyth Street, NW
 Atlanta, Georgia 30303-8960

For SWFWMD: Manager, Well Construction
 Regulation Performance Management Department
 Southwest Florida Water Management District
 2379 Broad Street
 Brooksville, Florida 34604-6899

5. This MOA shall become effective on the latest day and year executed by either the EPA or the SWFWMD as noted below.
6. Either party may terminate this MOA upon written notice to the other party.
7. The parties agree that this MOA imposes no formal contractual obligations and is not enforceable by either party against the other or by any third party.
8. Neither party is responsible for the funding, payment and/or reimbursement of any costs incurred by the other party for any activities performed pursuant to this MOA. Any provision of this MOA that may require an obligation of funds by EPA shall be subject to the availability of appropriated funds and no provision herein shall be interpreted to require obligation or payment of funds in violation of the Anti-Deficiency Act, 31 U.S.C. § 1341.

9. This MOA does not create any right or benefit, substantive or procedural, enforceable by law or equity, by persons who are not party to this agreement, against SWFWMD or EPA, their officers or employees, or any other person. This MOA does not direct or apply to any person outside of SWFWMD and EPA.

10. The undersigned representative(s) certify that they are fully authorized to execute this MOA.

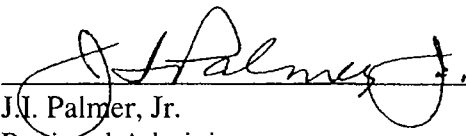
BY:  DATE: SEP 11 2008
J.I. Palmer, Jr.
Regional Administrator
U.S. Environmental Protection Agency

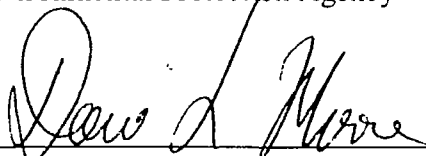
BY:  DATE: 8-26-08
David L. Moore
Executive Director
Southwest Florida Water Management

APPENDIX 1

1. Landia Chemical Superfund Site, EPA ID No. FLD042110841, Lakeland, Polk County, Florida (August 2008)

APPENDIX F

**CORPORATE GUARANTEE FOR PERFORMANCE OF WORK IN RD/RA
CONSENT DECREE**

Guarantee made this the ____ day of _____, 2009, by Potash Holding Company, Inc. ("Potash Holding Company"), a business corporation organized under the laws of the State of _____, herein referred to as the guarantor. This guarantee is made on behalf of PCS Joint Venture, Ltd ("PCS JV") the former owner of a portion of the Landia Chemical Company Superfund Site in Lakeland, Florida ("Site"). Both PCS JV and Potash Holding are indirect subsidiaries of same parent corporation, Potash Corporation of Saskatchewan (address) to the United States Environmental Protection Agency ("EPA").

RECITALS

1. Guarantor meets or exceeds the financial test criteria and agrees to comply with the reporting requirements for guarantors as specified in 40 CFR 264.143(f), 264.145(f), 265.143(e), and 265.145(e).
2. PCS JV is the former owner of a portion of the Site that is subject to the RD/RA Consent Decree entered on _____, 2009. United States vs. Landia Chemical Company, Inc., et al., C.A. No. _____ (U.S. Dist. Ct. Mid. Dist. Florida) ("Order").
3. For value received for PCS JV, Guarantor guarantees to EPA that in the event that PCS JV fails to perform the Work as required by the Order, the Guarantor shall do so.
4. Guarantor agrees that if, at the end of any fiscal year before termination of this guarantee, Guarantor fails to meet the financial test criteria, Guarantor shall send within 90 days, by certified mail, notice to the EPA Regional Administrator for Region 4 and to PCS JV that Guarantor intends to provide alternate financial assurance as specified in the Order, in the name of PCS JV. Within 120 days after the end of such fiscal year, the Guarantor shall establish such financial assurance unless PCS JV has done so.
5. The Guarantor agrees to notify the EPA Regional Administrator by certified mail, of a voluntary or involuntary proceeding under Title 11 (Bankruptcy), U.S. Code, naming Guarantor as debtor, within 10 days after commencement of the proceeding.
6. Guarantor agrees that within 30 days after being notified by the EPA Regional Administrator of a determination that the Guarantor no longer meets the financial test criteria or that Guarantor is disallowed from continuing as a guarantor of the Work, Guarantor shall establish alternate financial assurance as specified in the Order.

7. Guarantor agrees to remain bound under this Guarantee for as long as PCS JV must comply with the applicable financial assurance requirements of the Order.
8. Guarantor may terminate this Guarantee by sending notice by certified mail to the EPA Regional Administrator for Region 4 and to PCS JV, provided that this Guarantee may not be terminated unless and until PCS JV obtains, and the EPA Regional Administrator approves, alternate financial assurance.
9. Guarantor agrees that if PCS JV fails to provide alternate financial assurance as specified in the Order and obtain written approval of such assurance from the EPA Regional Administrator within 90 days after a notice of cancellation by the Guarantor is received by an EPA Regional Administrator from Guarantor, Guarantor shall provide such alternate assurance in the name of PCS JV.
10. Guarantor expressly waives notice of acceptance of this Guarantee by the EPA or by PCS JV. Guarantor also expressly waives notice of amendments or modifications Work.

Effective Date: _____
Potash Holding Company, Inc.
Guarantor
By: _____
Title: _____

Notary

GUARANTEE AGREEMENT

This GUARANTEE AGREEMENT, dated as of _____, 2009 (this "Guarantee"), is made by The Williams Companies Inc., a corporation organized and existing under the laws of the State of Delaware ("Guarantor"), to and for the benefit of the United States Environmental Protection Agency, an agency of the federal government of the United States of America ("EPA"). This Guarantee is made on behalf of Agrico Chemical Company ("Settling Defendant").

RECITALS

WHEREAS, pursuant to the Comprehensive Environmental Response, Compensation, and Liability Act of 1980, as amended, 42 U.S.C. § 9607 et seq. ("CERCLA"), Settling Defendant has entered into a Consent Decree with EPA, dated _____, 2009, Docket No. _____ (the "Consent Decree"), for certain environmental remediation work to be performed at the Landia Chemical Company Site (the "Site") near Lakeland, Florida;

WHEREAS, Section XIII of the Consent Decree requires that Settling Defendant provide financial assurance to EPA that funds or other resources will be available as and when needed to ensure completion of the work required to be conducted by Settling Defendant under the Consent Decree;

WHEREAS, in order to provide part of such financial assurance required by the Consent Decree, Settling Defendant has agreed to provide EPA with a guarantee, issued by Guarantor, of Settling Defendant's obligations arising under the Consent Decree, all as set forth more fully in this Guarantee;

WHEREAS, Settling Defendant has a substantial business relationship with Guarantor, and the Guarantor will receive benefits from the agreements made by and between EPA and Settling Defendant as set forth in the Consent Decree; and

WHEREAS, Guarantor has agreed to, among other things, guarantee payment and performance in full of the Guaranteed Obligations (as hereinafter defined) and undertake such other commitments to EPA or for EPA's benefit as set forth in this Guarantee.

AGREEMENT

NOW, THEREFORE, in consideration of the promises contained herein, and to induce EPA to enter into the Consent Decree and to settle with Settling Defendant under CERCLA as contemplated thereby, and for other good and valuable consideration, the receipt and adequacy of which are hereby acknowledged, Guarantor hereby agrees with EPA as follows:

ARTICLE I.
DEFINITIONS

1.1 Defined Terms. The following terms (whether or not underscored) when used in this Guarantee, including its preamble and recitals, shall have the following meanings:

“Affiliate” means, when used with respect to a specified entity, another entity that directly, or indirectly through one or more intermediaries, Controls or is Controlled by or is under common Control with the entity specified.

“Annual Audited Financial Statements” means an entity’s annual audited financial statements prepared in accordance with U.S. Generally Accepted Accounting Procedures.

“Control” means the possession, directly or indirectly, of the power to direct or cause the direction of the management or policies of an entity, whether through the ownership or control of voting securities, partnership interests or other equity interests, by contract, or otherwise, and “Controlling” and “Controlled” shall have meanings correlative thereto.

“EPA” has the meaning given in the preamble to this Guarantee.

“Guaranteed Obligations” means and includes all obligations and liabilities, howsoever arising, owed by Settling Defendant to EPA of every kind and description (whether or not for the payment of money), direct or indirect, absolute or contingent, due or to become due, now existing or hereafter arising, pursuant to the terms of the Consent Decree.

“Guarantor” has the meaning given in the preamble to this Guarantee.

“Guarantee” has the meaning given in the preamble to this Guarantee.

“Site” has the meaning given in the preamble to this Guarantee.

1.2 General Definitions. Unless otherwise defined herein or unless the context otherwise requires, capitalized terms used in this Guarantee, including its preamble and recitals, have the meanings provided in the Consent Decree.

ARTICLE II.
GUARANTEE

2.1 Guarantee.

(a) The obligations of Guarantor set forth in this Section 2.1 and the following Sections of this Agreement shall only apply and be limited to performance of the Consent Decree obligations at or associated with the Site.

(b) Guarantor, as primary obligor and not merely as surety, hereby unconditionally and irrevocably guarantees to EPA the prompt payment in full and the prompt performance in full of the Guaranteed Obligations.

(c) Guarantor agrees that if for any reason Settling Defendant shall fail to pay or perform, as the case may be, when due any of the Guaranteed Obligations, Guarantor shall promptly pay or perform, as the case may be, the same forthwith on the date such payment or performance of such Guaranteed Obligation is due or required, without regard to any exercise or non-exercise by Guarantor, Settling Defendant, or EPA of any right, remedy, power or privilege under or in respect of the Consent Decree, and that in the case of any extension of time of the payment, performance, or renewal of any of the Guaranteed Obligations, the same will be promptly paid or performed, as the case may be, in full when due in accordance with the terms of such extension or renewal.

(d) Without limiting the foregoing, Guarantor acknowledges and agrees that, with regard to Work Takeover Notice and Work Takeover by EPA, the procedures of Section XXI of the Consent Decree control as to the method and timing of payment of a cash amount up to but not exceeding the estimated cost of the remaining Work to be performed as of such date, as determined by EPA..

2.2 Obligations Absolute and Unconditional.

(a) The obligations of Guarantor hereunder are primary obligations of Guarantor and constitute an absolute, unconditional, continuing and irrevocable guarantee of payment and performance of the Guaranteed Obligations and the other obligations of Guarantor hereunder and not of collectibility, and are in no way conditioned on or contingent upon any attempt to enforce in whole or in part Settling Defendant's liabilities and obligations to EPA. Each failure by Guarantor to pay or perform, as the case may be, a Guaranteed Obligation or any other obligation hereunder shall give rise to a separate cause of action hereunder, and separate suits may be brought hereunder as each cause of action arises.

(b) EPA may, at any time and from time to time (whether or not after revocation or termination of this Guarantee) without the consent of or notice to Guarantor, except such notice as may be required by the Consent Decree or applicable law which cannot be waived, without incurring responsibility to Guarantor, without impairing or releasing the obligations of Guarantor hereunder, upon or without any terms or conditions and in whole or in part:

(i) change the manner, place and terms of payment or performance of, or renew or alter, any Guaranteed Obligation or any obligations and liabilities (including any of those hereunder) incurred directly or indirectly in respect thereof or hereof, or in any manner modify, amend or supplement the terms of the Consent Decree or any documents, instruments or agreements executed in connection therewith, in each case with the consent of Settling Defendant (in each case, as and to the extent required by the Consent Decree), and the agreements and guarantees herein made shall apply to the Guaranteed Obligations or such other obligations as changed, extended, renewed, modified, amended, supplemented or altered in any manner;

(ii) exercise or refrain from exercising any rights against Settling Defendant or others (including Guarantor) or otherwise act or refrain from acting;

(iii) add or release any other guarantor from its obligations without affecting or impairing the obligations of Guarantor hereunder;

(iv) settle or compromise any Guaranteed Obligations or any obligations and liabilities incurred directly or indirectly in respect thereof;

(v) consent to or waive any breach of, or any act, omission or default under, the Consent Decree or otherwise amend, modify or supplement (with the consent of Settling Defendant, as and to the extent required by the Consent Decree) the Consent Decree or any of such other instruments or agreements; and/or

(viii) act or fail to act in any manner referred to in this Guarantee which may deprive Guarantor of its right to subrogation against Settling Defendant to recover full indemnity for any payments or performances made pursuant to this Guarantee or of its right of contribution against any other party.

(c) No invalidity, irregularity or unenforceability of the Guaranteed Obligations or invalidity, irregularity, unenforceability or non-perfection of any collateral therefor, shall affect, impair or be a defense to this Guarantee, which is a primary obligation of Guarantor.

(d) This is a continuing Guarantee and all obligations to which it applies or may apply under the terms hereof shall be conclusively presumed to have been created in reliance hereon. In the event that, notwithstanding the provisions of Section 2.2(a) above, this Guarantee shall be deemed revocable in accordance with applicable law, then any such revocation shall become effective only upon receipt by EPA of written notice of revocation signed by Guarantor. To the extent permitted by applicable law, no revocation or termination hereof shall affect, in any manner, rights arising under this Guarantee with respect to Guaranteed Obligations arising prior to receipt by EPA of written notice of such revocation or termination. Any such revocation or termination without EPA's prior written consent shall be deemed to be a violation of the Consent Decree.

ARTICLE III. REPRESENTATIONS AND WARRANTIES

3.1 Guarantor Representations and Warranties. Guarantor represents and warrants to and in favor of EPA, as of the date of this Guarantee, that:

3.1.1 Existence. Guarantor is duly organized and validly existing under the laws of the jurisdiction of its incorporation and is qualified to do business in such jurisdiction and in each other jurisdiction in which the conduct of its business requires such qualification, except to the extent the failure to be so qualified would not have a material adverse effect. Power

and Authorization. Guarantor has full power and authority to enter into and execute this Guarantee. This Guarantee has been duly authorized, executed and delivered by Guarantor.

3.1.3 No Conflict. The execution, delivery and performance by Guarantor of this Guarantee and the execution, delivery, and performance by Settling Defendant of the Consent Decree do not and will not (a) violate any provision of (i) any legal requirement applicable to Guarantor, (ii) the organizational and other corporate governance documents of Guarantor or (iii) any order, judgment or decree of any court or agency or governmental instrumentality binding on Guarantor, (b) conflict with, result in a breach of, or constitute a default under any material contractual obligation of Guarantor, (c) result in or require the creation or imposition of any lien upon any of the properties or assets of Guarantor, or (d) require any approval or consent of any person or entity, except for such approvals or consents which will be obtained on or before the date of this Guarantee and which have been disclosed in writing to EPA.Enforceable Obligations. This Guarantee constitutes a legal, valid and binding obligation of Guarantor, enforceable in accordance with its terms, except to the extent that enforceability may be limited by applicable bankruptcy, insolvency, moratorium, reorganization or other similar laws affecting the enforcement of creditors' rights generally.

3.1.5 Compliance with Law; Fraud. Guarantor (i) is not in violation of any applicable legal requirements in any material respect and (ii) is not subject to or in default in any material respect with respect to any final judgments, writs, injunctions, decrees, rules or regulations of any court or any federal, state, municipal or other governmental department, commission, board, bureau, agency or instrumentality, domestic or foreign, in the case of either (i) or (ii) which would have a material adverse effect on the ability of Guarantor to perform its obligations under this Guarantee. Guarantor is not executing this Guarantee with any intention to hinder, delay or defraud any present or future creditor or creditors of Guarantor.

3.1.6 Relationship To Settling Defendant. Guarantor has a "substantial business relationship" (as defined in 40 C.F.R. § 264.141(h)) with Settling Defendant.

3.1.7 No Bankruptcy Filing. Guarantor is not contemplating either the filing of a petition by it under any state or federal bankruptcy or insolvency laws or the liquidation of all or a major portion of its assets or property, and Guarantor has no knowledge of any person contemplating the filing of any such petition against it.

ARTICLE IV. COVENANTS

Guarantor hereby covenants and agrees for the benefit of EPA, until this Guarantee is terminated pursuant to Section 6.16, as follows:

4.1 Maintenance of Corporate Existence. Guarantor shall maintain and preserve its existence and all material rights, privileges and franchises necessary in the normal conduct of its business. Guarantor shall notify EPA in writing within 60 days after any change in its name or place of business or chief executive office, or change in its type of organization or

jurisdiction of organization.Compliance with Laws. Guarantor shall promptly comply, or cause compliance, in all material respects with all legal requirements to the extent any noncompliance with such legal requirements could have a material adverse effect on the ability of Guarantor to perform and discharge its obligations under this Guarantee.Notice of Bankruptcy or Insolvency, Etc. Guarantor shall notify EPA promptly after the occurrence of any of the following: filing by the Guarantor of a petition seeking to take advantage of any laws relating to bankruptcy, insolvency, reorganization, winding up or composition or adjustment of debts; Guarantor's consent to (or failure to contest in a timely manner) any petition filed against it in an involuntary case under such bankruptcy or other laws; Guarantor's application for (or consent to or failure to contest in a timely manner) the appointment of, or the taking of possession by, a receiver, custodian, trustee, liquidator, or the like of itself or of all or a substantial part of its assets; Guarantor's making a general assignment for the benefit of creditors; or Guarantor's taking any publicly disclosed corporate action for the purpose of effecting any of the foregoing

4.4 Further Assurances. Guarantor shall promptly provide EPA with such information and other documents related to this Guarantee and the Guaranteed Obligations that EPA may reasonably request that are publicly available.

4.5 Compliance with Financial Measures. Guarantor shall at all times during the term of this Guarantee comply with and satisfy the financial measures and conditions set forth in either Exhibit A or Exhibit B attached hereto. Guarantor shall also notify EPA promptly after filing the 10K if, at any time during the term hereof, Guarantor fails any of the financial measures set forth in Exhibit A or Exhibit B, as the case may be.Submission of Documents. For so long as this Guarantee is in effect, within 105 days after the close of each fiscal year of Guarantor, Guarantor shall submit to EPA:

(a) a letter signed by Guarantor's Chief Financial Officer certifying Guarantor's compliance with the financial conditions and measures set forth in either Exhibit A or Exhibit B, which letter shall be substantially in the form of Exhibit C attached hereto; and

(b) a copy of Guarantor's audited financial statements for its latest completed fiscal year, and a copy of the Guarantor's independent certified public accountant's report on examination of such financial statements, which report on examination shall be unqualified or, if qualified, shall have been approved in writing by EPA; and

(c) a special report from Guarantor's independent certified public accountant to Guarantor attesting to Guarantor's compliance with the financial conditions and measures set forth in either Exhibit A or Exhibit B, which special report shall be substantially in the form of Exhibit D hereto.

ARTICLE V. SUBROGRATION; ETC.

5.1 Waiver. Guarantor hereby unconditionally and irrevocably waives and relinquishes, to the maximum extent permitted by applicable legal requirements, all rights and remedies accorded to sureties or guarantors and agrees not to assert or take advantage of any

such rights or remedies, including: any right to require EPA to proceed against Settling Defendant or any other person or to pursue any other remedy in EPA's power before proceeding against Guarantor;

(b) any defense that may arise by reason of the incapacity, lack of power or authority, dissolution, merger, or termination of Guarantor, Settling Defendant, or any other person or the failure of EPA to file or enforce a claim against the estate (in administration, bankruptcy or any other proceeding) of Guarantor or Settling Defendant, or any other person;

(c) promptness, diligence, demand, presentment, protest and notice of any kind, including notice of the existence, creation or incurring of any new or additional indebtedness or obligation or of any action or non-action on the part of Settling Defendant or EPA;

(d) any defense based upon an election of remedies by EPA, which destroys or otherwise impairs the subrogation rights of Guarantor, the right of Guarantor to proceed against Settling Defendant or another person for reimbursement, or both;

(e) any defense based on any offset against any amounts which may be owed by any person to Guarantor for any reason whatsoever;

(f) any defense based on any act, failure to act, delay or omission whatsoever on the part of Settling Defendant or the failure by Settling Defendant to do any act or thing or to observe or perform any covenant, condition or agreement to be observed or performed by it under the Consent Decree;

(g) any defense based upon any statute or rule of law which provides that the obligation of a surety must be neither larger in amount nor in other respects more burdensome than that of the principal;

(h) any defense, setoff or counterclaim which may at any time be available to or asserted by Settling Defendant against EPA or any other person under the Consent Decree;

(i) any duty on the part of EPA to disclose to Guarantor any facts EPA may now or hereafter know about Settling Defendant or the Site, regardless of whether EPA has reason to believe that any such facts materially increase the risk beyond that which Guarantor intends to assume, or have reason to believe that such facts are unknown to Guarantor, or have a reasonable opportunity to communicate such facts to Guarantor, since Guarantor acknowledges that Guarantor is fully responsible for being and keeping informed of the financial condition of Settling Defendant and of all circumstances bearing on the risk of non-payment or non-performance of any Guaranteed Obligation;

(j) any defense based on any change in the time, manner or place of any payment or performance under, or in any other term of, the Consent Decree, or any other amendment, renewal, extension, acceleration, compromise or waiver of or any consent or departure from the terms of the Consent Decree;

(k) any right to assert the bankruptcy or insolvency of Settling Defendant or any other person as a defense hereunder or as the basis for rescission hereof and any defense arising because of EPA's institution of any proceeding under the Federal Bankruptcy Code; and

(l) any other circumstance (including any statute of limitations), any act or omission by Settling Defendant, or any existence of or reliance on any representation by Settling Defendant or EPA that might otherwise constitute a defense available to, or discharge of, any guarantor or surety.

5.2 Subrogation. Until this Guarantee is terminated in accordance with Section 6.16 below, neither Guarantor nor Settling Defendant shall exercise any right of subrogation or enforce any remedy which it now may have or may hereafter have against any person in respect of the Guaranteed Obligations, whether or not such claim, right or remedy arises in equity, under contract, by statute, under common law or otherwise. Bankruptcy.

(a) The obligations of Guarantor under this Guarantee shall not be altered, limited or affected by any proceeding, voluntary or involuntary, involving the bankruptcy, reorganization, insolvency, receivership, liquidation or arrangement of Settling Defendant or any Affiliate thereof, or by any defense which Settling Defendant or any Affiliate thereof may have by reason of any order, decree or decision of any court or administrative body resulting from any such proceeding.

(b) Guarantor hereby irrevocably waives, to the extent it may do so under applicable legal requirements, any protection against enforcement of this Guarantee to which it may be entitled under the Federal Bankruptcy Code or equivalent provisions of the laws or regulations of any other jurisdiction with respect to any proceedings, or any successor provision of law of similar import, in the event of any bankruptcy event with respect to Settling Defendant. Specifically, in the event that the trustee (or similar official) in a bankruptcy event with respect to Settling Defendant or the debtor-in-possession takes any action (including the institution of any action, suit or other proceeding for the purpose of enforcing the rights of Settling Defendant under this Guarantee), Guarantor shall not assert any defense, claim or counterclaim denying liability hereunder on the basis that this Guarantee or the Consent Decree is an executory contract or a "financial accommodation" that cannot be assumed, assigned or enforced or on any other theory directly or indirectly based on the Federal Bankruptcy Code, or equivalent provisions of the law or regulations of any other jurisdiction with respect to any proceedings or any successor provision of law of similar import. If a bankruptcy event with respect to Settling Defendant shall occur, Guarantor agrees, after the occurrence of such bankruptcy event, to reconfirm in writing, to the extent permitted by applicable legal requirements and at EPA's written request, its pre-petition waiver of any protection to which it may be entitled under the Federal Bankruptcy Code or equivalent provisions of the laws or regulations of any other jurisdiction with respect to proceedings and, to give effect to such waiver, Guarantor consents to the assumption and enforcement of each provision of this Guarantee by the debtor-in-possession or Settling Defendant's trustee in bankruptcy, as the case may be.

5.4 Reinstatement. This Guarantee and the obligations of Guarantor hereunder shall continue to be effective or be automatically reinstated, as the case may be, if and to the extent that for any reason any payment or performance by or on behalf of Guarantor in respect of the Guaranteed Obligations is rescinded or otherwise restored to Guarantor or Settling Defendant, whether as a result of any proceedings in bankruptcy or reorganization or otherwise, all as if such payment or performance had not been made, and Guarantor agrees that it will indemnify EPA on demand for all reasonable costs and expenses (including reasonable fees of counsel) incurred by EPA in connection with any such rescission or restoration.

ARTICLE VI.
MISCELLANEOUS

6.1 Obligations Secured. Without limiting the generality of the foregoing, this Guarantee secures the payment and performance when due of all Guaranteed Obligations. If, notwithstanding the representation and warranty set forth in Section 3.1.4 or anything to the contrary herein, enforcement of the liability of Guarantor under this Guarantee for the full amount of the Guaranteed Obligations would be an unlawful or voidable transfer under any applicable fraudulent conveyance or fraudulent transfer law or any comparable law, then the liability of Guarantor hereunder shall be reduced to the highest amount for which such liability may then be enforced without giving rise to an unlawful or voidable transfer under any such law.

6.2 Successions or Assignments. This Guarantee is binding upon Guarantor and its successors and permitted assigns. Guarantor may not assign any of its obligations hereunder without the prior written consent of EPA (and any purported assignment in violation of this Section shall be void).

6.3 Other Waivers. No delay or omission on the part of EPA in exercising any of its rights (including those hereunder) and no partial or single exercise thereof and no action or non-action by EPA, with or without notice to Guarantor, Settling Defendant, or any other person, shall constitute a waiver of any rights or shall affect or impair this Guarantee.

6.4 Headings. The headings in this Guarantee are for convenience of reference only and shall not constitute a part of this Guarantee for any other purpose or be given any substantive effect.

6.5 Remedies Cumulative. Each and every right and remedy of EPA hereunder shall be cumulative and shall be in addition to any other right or remedy given hereunder or under the Consent Decree, or now or hereafter existing at law or in equity.

6.6 Severability. Any provision of this Guarantee that may be determined by competent authority to be prohibited or unenforceable in any jurisdiction shall, as to such jurisdiction, be ineffective to the extent of such prohibition or unenforceability without invalidating the remaining provisions hereof, and any such prohibition or unenforceability in any jurisdiction shall not invalidate or render unenforceable such provision in any other jurisdiction.

6.7 Amendments. This Guarantee may be amended, waived or otherwise modified only with the written consent of the parties hereto, the written consent of EPA and otherwise in accordance with the terms of the Consent Decree.

6.8 Jurisdiction. Guarantor agrees that any legal action or proceeding by or against Guarantor or with respect to or arising out of this Guarantee may be brought by the United States in or removed to [INSERT DISTRICT COURT ENTERING CONSENT DECREE.] By execution and delivery of this Guarantee, Guarantor accepts, for itself and in respect of its property, generally and unconditionally, the non-exclusive jurisdiction of the aforesaid court. Guarantor irrevocably consents to the service of process out of the aforementioned court in any manner permitted by law. Any such process or summons in connection with any such action or proceeding may also be served by mailing a copy thereof by certified or registered mail, or any substantially similar form of mail, addressed to Guarantor as provided for notices hereunder. Guarantor hereby waives any right to stay or dismiss any action or proceeding under or in connection with this Guarantee or the Consent Decree brought before the foregoing court on the basis of *forum non-conveniens*. Nothing herein shall affect the right of EPA to bring legal action or proceedings in any other competent jurisdiction.

6.9 Governing Law. This Guarantee and the rights and obligations of EPA and Guarantor shall be governed by, and construed in accordance with, the law of the State of [] without reference to principles of conflicts of law.

6.10 Integration of Terms. This Guarantee, together with the Consent Decree, is intended by the parties as a final expression of their agreement and is intended as a complete and exclusive statement of the terms and conditions thereof.

6.11 Notices. Any communications between the parties hereto or notices provided herein to be given may be given to the following addresses:

If to Guarantor:

Attention: _____
Telephone: _____
Facsimile: _____

If to EPA:

EPA Regional Administrator or Regional Superfund Director for
EPA Region [] (or any of their designees)

Attention: _____
Telephone: _____
Facsimile: _____

With a copy to:

[ORC Contact; RPM]

Attention: _____
Telephone: _____
Facsimile: _____

All notices or other communications required or permitted to be given hereunder shall be in writing and shall be considered as properly given (a) if delivered in person, (b) if sent by overnight delivery service (including Federal Express, UPS and other similar overnight delivery services), (c) if mailed by first class United States Mail, postage prepaid, registered or certified with return receipt requested, (d) if sent by facsimile or (e) if sent via other electronic means (including electronic mail). Notice so given shall be effective upon receipt by the addressee, except that communication or notice so transmitted by facsimile or other direct written electronic means shall be deemed to have been validly and effectively given on the day on which it is transmitted if transmitted before 4:00 p.m., recipient's time, and if transmitted after that time, on the next following Banking Day; provided, however, that (i) if any notice is tendered to an addressee and the delivery thereof is refused by such addressee, such notice shall be effective upon such tender, and (ii) with respect to any notice given via facsimile or other electronic means, the sender of such message shall promptly provide the addressee with an original copy of such notice by any of the means specified in clauses (a), (b) or (c) above. Any party shall have the right to change its address for notice hereunder to any other location within the continental United States by giving five days' notice to the other parties in the manner set forth above.

6.12 Collection Expenses.

(a) Without regard to any limitation set forth in this Guarantee, if EPA is required to pursue any remedy against Guarantor hereunder, Guarantor shall pay to EPA upon demand therefore, all reasonable attorneys' fees and all other costs and expenses incurred by EPA in enforcing this Guarantee (and such fees, costs and expenses shall be deemed to be part of the Guaranteed Obligations).

6.13 Counterparts. This Guarantee and any amendments, waivers, consents or supplements hereto or in connection herewith may be executed in any number of counterparts and by different parties hereto in separate counterparts, each of which when so executed and delivered shall be deemed an original, but all such counterparts together shall constitute one and the same agreement.

6.14 Limitations on Liability. No claim shall be made by Guarantor against EPA or any of its employees, attorneys or agents for any loss of profits, business or anticipated savings, special or punitive damages or any indirect or consequential loss whatsoever in respect of any breach or wrongful conduct (whether or not the claim therefor is based on contract, tort or duty imposed by law), in connection with, arising out of or in any way related to the transactions contemplated by this Guarantee or the Consent Decree or any act or omission or event occurring in connection therewith; and Guarantor hereby waives, releases and agrees not to sue upon any such claim for any such damages, whether or not accrued and whether or not known or suspected to exist in their favor.

6.15 Time. Time is of the essence of this Guarantee.

6.16 Termination. Subject to Section 5.4, this Guarantee and all of the obligations of Guarantor hereunder shall terminate upon the earlier of (a) payment and

performance in full of all Guaranteed Obligations in accordance with the Consent Decree and (b) the substitution of a different financial assurance mechanism in accordance with Section [] of the Consent Decree as consent to in writing by EPA. Unless earlier terminated pursuant to the foregoing sentence, this Guarantee shall survive any foreclosure proceedings instituted, commenced, or completed against Settling Defendant.

6.17 Consent Decree. Guarantor acknowledges that it has been provided with a copy of the Consent Decree and has read and is familiar with the provisions of the Consent Decree.

[REMAINDER OF PAGE INTENTIONALLY LEFT BLANK]

IN WITNESS WHEREOF, the parties hereto, by their authorized representatives duly authorized, intending to be legally bound, have caused this Guarantee to be duly executed and delivered as of the date first above written.

[INSERT NAME OF GUARANTOR],
a _____ corporation,
as Guarantor

By: _____
Name:
Title:

[NOTARY BLOCK]

EXHIBIT A

Section 4.5(a) Financial Conditions

As calculated from the data contained in Guarantor's Annual Audited Financial Statement, the Guarantor must:

- (A) Satisfy two of the following three ratios: (1) a ratio of total liabilities to Net Worth less than 2.0; (2) a ratio of the sum of net income plus depreciation, depletion, and amortization to total liabilities greater than 0.1; and (3) a ratio of current assets to current liabilities greater than 1.5; and
- (B) Have a Net Working Capital and Tangible Net Worth each at least six times the Total Value of Environmental Obligations; and
- (C) Have a Tangible Net Worth of at least \$10 million; and
- (D) Have assets located in the United States amounting to at least 90 percent of total assets or at least six times the Total Value of Environmental Obligations.

Defined Terms for Exhibit A and Exhibit B

"Net Working Capital" means current assets minus current liabilities.

"Net Worth" means total assets minus total liabilities.

"Tangible Net Worth" means the value of tangible assets included in the calculation of Net Worth; this value would not include the value of intangibles such as goodwill and rights to patents or royalties.

"Total Value of Environmental Obligations" means the sum of:

(a) the dollar amount of financial assurance required by Paragraph [] of the Consent Decree [or the relevant portion if multiple financial assurance mechanisms are being used];

(b) the total dollar amount of financial assurance provided by the Guarantor to EPA through the use of a financial test and/or a guarantee for CERCLA settlements other than that embodied in the Consent Decree; and

(c) the total dollar amount of financial assurance provided by the Guarantor to EPA through the use of a financial test and/or a guarantee for purposes of any facility regulated under federal environmental programs other than CERCLA, including but not limited to hazardous waste Treatment, Storage, and Disposal ("TSD") facilities under 40 CFR parts 264 and 265, Municipal Solid Waste Landfill ("MSWLF") facilities under 40 CFR part 258, Underground Injection Control ("UIC") facilities under 40 CFR part 144, Underground Storage Tank ("UST") facilities under 40 CFR part 280, and Polychlorinated Biphenyl ("PCB") storage facilities under 40 CFR part 761.

EXHIBIT B

Section 4.5(b) Financial Conditions

The Guarantor must have:

- (A) A current rating for its most recent bond issuance of AAA, AA, A, or BBB as issued by Standard and Poor's or Aaa, Aa, A, or Baa as issued by Moody's; and
- (B) Tangible Net Worth at least six times the Total Value of Environmental Obligations; and
- (C) Tangible Net Worth of at least \$10 million; and
- (D) Assets located in the United States amounting to at least 90 percent of total assets or at least six times the Total Value of Environmental Obligations.

Defined Terms for Exhibit A and Exhibit B

"Net Working Capital" means current assets minus current liabilities.

"Net Worth" means total assets minus total liabilities.

"Tangible Net Worth" means the value of tangible assets included in the calculation of Net Worth; this value would not include the value of intangibles such as goodwill and rights to patents or royalties.

"Total Value of Environmental Obligations" means the sum of:

(a) the dollar amount of financial assurance required by Paragraph [] of the Consent Decree [or the relevant portion if multiple financial assurance mechanisms are being used];

(b) the total dollar amount of financial assurance provided by the Guarantor to EPA through the use of a financial test and/or a guarantee for CERCLA settlements other than that embodied in the Consent Decree; and

(c) the total dollar amount of financial assurance provided by the Guarantor to EPA through the use of a financial test and/or a guarantee for purposes of any facility regulated under federal environmental programs other than CERCLA, including but not limited to hazardous waste Treatment, Storage, and Disposal ("TSD") facilities under 40 CFR parts 264 and 265, Municipal Solid Waste Landfill ("MSWLF") facilities under 40 CFR part 258, Underground Injection Control ("UIC") facilities under 40 CFR part 144, Underground Storage Tank ("UST") facilities under 40 CFR part 280, and Polychlorinated Biphenyl ("PCB") storage facilities under 40 CFR part 761.

EXHIBIT C

Form CFO Letter

EXHIBIT D

Form Auditors' Letter

DRAFT COPY

Page: <u>1/1</u>	Irrevocable Letter of Credit	L/C Number: XXXXXX-793
Place and date of issue: <u>NEW YORK XX/XX/09</u>		
Date and place of expiry: <u>XX/XX/10 NEW YORK</u>		
Applicant: BASF CORPORATION ON BEHALF OF BASF SPARKS LLC (NEED COMPLETE ADDRESS)	Beneficiary: U.S. ENVIRONMENTAL PROTECTION AGENCY <input type="checkbox"/> C/O FRANKLIN HILL, REGIONAL SUPERFUND DIRECTOR <input type="checkbox"/> DIRECTOR, SUPERFUND DIVISION, EPA REGION IV <input type="checkbox"/> 61 FORSYTH STREET, S.W. ATLANTA, GA 30303-8960	

DEAR SIR OR MADAM:

WE HEREBY ESTABLISH OUR IRREVOCABLE STANDBY LETTER OF CREDIT NO. XXXXXX-793 IN YOUR FAVOR, AT THE REQUEST AND FOR THE ACCOUNT OF THE BASF SPARKS LLC, IN THE AMOUNT OF EXACTLY TWO MILLION EIGHT HUNDRED THIRTY THREE THOUSAND THREE HUNDRED THIRTY FOUR AND NO/100 U.S. DOLLARS (US\$2,833,334.00) (THE "MAXIMUM AMOUNT"). WE HEREBY AUTHORIZE YOU, THE U.S. ENVIRONMENTAL PROTECTION AGENCY (THE "BENEFICIARY"), TO DRAW AT SIGHT ON US, LOCATED AT ONE WILLIAM STREET, NEW YORK, NY 10004, AN AGGREGATE AMOUNT EQUAL TO THE MAXIMUM AMOUNT UPON PRESENTATION OF:

(1) YOUR SIGHT DRAFT, BEARING REFERENCE TO THIS LETTER OF CREDIT NO. XXXXXX-793 (WHICH MAY, WITHOUT LIMITATION, BE PRESENTED IN THE FORM ATTACHED HERETO AS EXHIBIT A); AND

(2) YOUR SIGNED STATEMENT READING AS FOLLOWS: "I CERTIFY THAT THE AMOUNT OF THE DRAFT IS PAYABLE PURSUANT TO THAT CERTAIN CONSENT DECREE, DATED _____, 2009, BY AND AMONG THE UNITED STATES AND LANDIA CHEMICAL COMPANY, INC.; AGRICO CHEMICAL COMPANY; BASF SPARKS LLC; PCS JOINT VENTURE, LTD.; SYLVITE TERMINAL & DISTRIBUTING LLC, BILLY G. MITCHELL AND WALTER G. GRAHN, ENTERED INTO BY THE PARTIES THERETO IN ACCORDANCE WITH THE AUTHORITY OF THE COMPREHENSIVE ENVIRONMENTAL RESPONSE, COMPENSATION, AND LIABILITY ACT (CERCLA)."

THIS LETTER OF CREDIT IS EFFECTIVE AS OF [INSERT ISSUANCE DATE] AND SHALL EXPIRE ON [A DATE FOR 1 YEAR LATER], BUT SUCH EXPIRATION DATE SHALL BE AUTOMATICALLY EXTENDED FOR A PERIOD OF ONE (1) YEAR ON [THE DATE 1 YEAR LATER] AND ON EACH SUCCESSIVE EXPIRATION DATE, UNLESS, AT LEAST ONE HUNDRED TWENTY (120) DAYS BEFORE THE CURRENT EXPIRATION DATE, WE NOTIFY BOTH YOU AND BASF SPARKS LLC BY CERTIFIED MAIL OR OVERNIGHT COURIER SERVICE THAT WE HAVE DECIDED NOT TO EXTEND THIS LETTER OF CREDIT BEYOND THE CURRENT EXPIRATION DATE. IN THE EVENT YOU ARE SO NOTIFIED, ANY UNUSED PORTION OF THE CREDIT SHALL IMMEDIATELY THEREUPON BE AVAILABLE TO YOU UPON PRESENTATION OF YOUR SIGHT DRAFT FOR A PERIOD OF AT LEAST 120 DAYS AFTER THE DATE OF RECEIPT BY BOTH YOU AND BASF SPARKS LLC OF SUCH NOTIFICATION, AS SHOWN ON SIGNED RETURN RECEIPTS.

MULTIPLE AND PARTIAL DRAWS ON THIS LETTER OF CREDIT ARE EXPRESSLY PERMITTED, UP TO AN AGGREGATE AMOUNT NOT TO EXCEED THE MAXIMUM AMOUNT. WHENEVER THIS LETTER OF CREDIT IS DRAWN ON, UNDER, AND IN COMPLIANCE WITH THE TERMS HEREOF, WE SHALL DULY HONOR SUCH DRAFT UPON PRESENTATION TO US, AND WE SHALL DEPOSIT THE AMOUNT OF THE DRAFT IN IMMEDIATELY AVAILABLE FUNDS DIRECTLY INTO SUCH ACCOUNT OR ACCOUNTS AS MAY BE SPECIFIED IN ACCORDANCE WITH YOUR INSTRUCTIONS.

ALL BANKING AND OTHER CHARGES UNDER THIS LETTER OF CREDIT ARE FOR THE ACCOUNT OF THE APPLICANT.

THIS LETTER OF CREDIT IS SUBJECT TO THE MOST RECENT EDITION OF THE UNIFORM CUSTOMS AND PRACTICE FOR DOCUMENTARY CREDITS, PUBLISHED AND COPYRIGHTED BY THE INTERNATIONAL CHAMBER OF COMMERCE.

KINDLY ACKNOWLEDGE RECEIPT BY MAIL.

DRAFT COPY

EXHIBIT A - FORM OF SIGHT DRAFT

TO: INTESA SANPAOLO SPA
ONE WILLIAM STREET,
NEW YORK, NY 10004

RE: LETTER OF CREDIT NO. XXXXXX-793

DATE: [INSERT DATE THAT DRAW IS MADE]

THIS DRAFT IS DRAWN UNDER YOUR IRREVOCABLE LETTER OF CREDIT NO. XXXXXX-793. PAY TO THE ORDER OF THE U.S. ENVIRONMENTAL PROTECTION AGENCY, IN IMMEDIATELY AVAILABLE FUNDS, THE AMOUNT OF [IN WORDS] U.S. DOLLARS (U.S.\$ [_____])

PAY SUCH AMOUNT AS IS SPECIFIED IN THE IMMEDIATELY PRECEDING PARAGRAPH BY FED WIRE ELECTRONIC FUNDS TRANSFER ("EFT") TO THE LANDIA CHEMICAL SUPERFUND SITE SPECIAL ACCOUNT WITHIN THE EPA HAZARDOUS SUBSTANCE SUPERFUND IN ACCORDANCE WITH CURRENT EFT PROCEDURES, REFERENCING FILE NUMBER [_____] , EPA REGION AND SITE SPILL ID NUMBER [_____] , AND DOJ CASE NUMBER [_____] , AS FOLLOWS:

[INSERT SPECIFIC SPECIAL ACCOUNT WIRING INSTRUCTIONS AND INFORMATION] .

THIS SIGHT DRAFT HAS BEEN DULY EXECUTED BY THE UNDERSIGNED, AN AUTHORIZED REPRESENTATIVE OR AGENT OF THE UNITED STATES ENVIRONMENTAL PROTECTION AGENCY, WHOSE SIGNATURE HEREUPON CONSTITUTES AN ENDORSEMENT.

BY: U.S. ENVIRONMENTAL PROTECTION AGENCY

_____ [SIGNATURE]
_____ [NAME]
_____ [TITLE]