



# Decentralized Systems Technology Fact Sheet Recirculating Sand Filters

## DESCRIPTION

A recirculating sand filter (RSF) system is a modified version of the old-fashioned, single-pass open sand filter. It was designed to alleviate the odor problems associated with open sand filters. The noxious odors were eliminated through recirculation, which increases the oxygen content in the effluent that is distributed on the filter bed.

RSFs are a viable addition or alternative to conventional methods of treatment when soil conditions are not conducive to proper treatment or wastewater disposal through percolative beds/trenches. Sand filters can be used on sites that have shallow soil cover, inadequate permeability, high groundwater, and limited land area. RSFs

commonly serve subdivisions, mobile home parks, rural schools, small municipalities, and other generators of small wastewater flows.

Sand filters remove contaminants in wastewater through physical, chemical, and biological processes. Although the physical and chemical processes play an important role in the removal of many particles, the biological processes play the most important role in sand filters.

Figure 1 shows the three basic components of a RSF system. These three components are a pretreatment unit, a recirculation tank, and an open sand filter.

Wastewater first flows into a septic tank (or in the

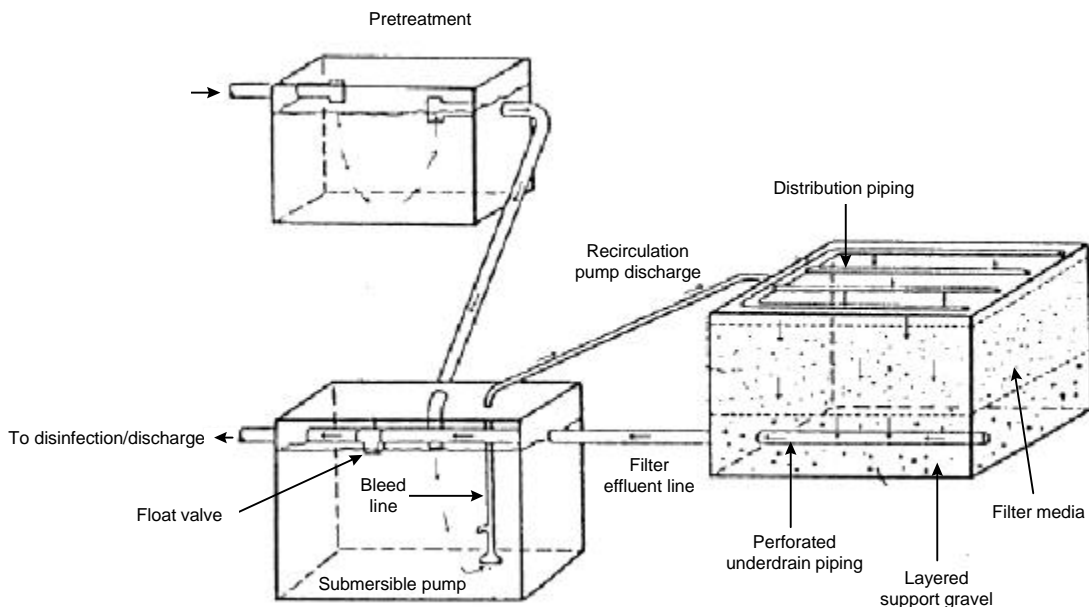

**FIGURE 1 TYPICAL RECIRCULATING SAND FILTER**

case of a clustered or community system, a number of septic tanks) for primary treatment. A standard concrete or fiberglass septic tank can be used, with size being relative to the home/facility served.

The partially clarified effluent from the pretreatment tank then flows into a recirculation tank. The volume of the recirculation tank should be equivalent to at least 1 day's raw wastewater flow (or follow local jurisdiction requirements). In the recirculation tank, raw effluent from the septic tank and the sand filter filtrate are mixed and pumped back to the sand filter bed.

## APPLICABILITY

### Stonehurst Development in Martinez, California

The Stonehurst development is a small residential subdivision near the City of Martinez in Contra Costa County, California. This subdivision is located in a hilly, rural area that did not have a wastewater collection system. Thus, an innovative decentralized wastewater system was designed to provide for wastewater collection, treatment, disinfection, and reuse.

The innovative system combines the use of septic tanks, screened effluent filter vaults, high-head effluent pumps, small-diameter variable grade sewers, pressure sewers, a recirculating granular medium filter, an ultraviolet (UV) disinfection unit, a subsurface drip irrigation system for wastewater reuse, and a community soil absorption field for wintertime disposal. The principle elements for treatment consisted of two sections of recirculating granular filter followed by disinfection.

Each filter was 24 inches deep with 3 millimeter gravel (washed and rounded with less than 2% fines) sandwiched between layers of drain rock, which was coarse, washed gravel approximately 1 to 2.5 inches in diameter. The wastewater was pumped from the recirculating tank to the filters for five minutes every half hour, and circulated approximately five times through the filter. Since one half of the filter was used during the time the study was conducted, the hydraulic loading was 1.2 gal/ft<sup>2</sup>.

Performance data was calculated for 28 months from June 1994 to September 1996, based on an average of at least two samples per month for five-day BOD, and at least four samples per month for TSS, chemical oxygen demand (COD), pH, and total coliform. Table 1 summarizes the performance data of effluent samples that passed through the recirculating gravel filter and the UV system.

To date, the Stonehurst decentralized wastewater system has exceeded all expectations by performing beyond required standards.

**TABLE 1 PERFORMANCE DATA FOR STONEHURST WASTEWATER TREATMENT SYSTEM**

Constituent	Range
BOD <sub>5</sub>	0 - < 5 mg/L
COD	1 - 18 mg/L
TSS	2 - 15 mg/L
pH	6.96 - 8.65 unitless
Total coliform	< 2 - 12.5 MPN/100 mL
NH <sub>4</sub>	0 - 15 mg/L
NO <sub>3</sub>	3.55 - 37 mg/L
TKN	0 - 3 mg/L
Oil and grease	0 - 12 mg/L
TDS	340 - 770 mg/L
EC	433 - 1,200 μmhos/cm

\* TDS - total dissolved solids, EC = electrical conductivity, μmhos/cm - micro mhos per centimeter

Source: Crites et al., 1997.

### Elkton, Oregon

A RSF system was installed and monitored for a community in Elkton, which is located on the Umpqua River in Southwestern Oregon. The population of this community was 350, mostly residential with some commercial establishments. The wastewater generated from stores, restaurants, schools, and about 100 residences was first pretreated and screened in individual septic tanks. Partially clarified effluent was then collected and

conveyed by an effluent pressure sewer system to a RSF and finally pumped to a drainfield for final treatment and disposal.

The sand filter was 60 feet x 120 feet with four cells, 36 inches deep, and designed to treat 30,000 gallons per day (gpd). A recirculation tank of 29,500-gallon capacity was used with four one-horsepower pumps. Each pump dosed one cell at the rate of 130 gallons per minute. Two pumps alternately dosed during each cycle. The actual recirculation ratio was 3.2:1, and during low periods, a motorized valve allowed 100% recirculation.

Effluent quality data obtained from February 1990 through October 1997 are presented in Table 2.

It was concluded from this study that the RSF produced a high quality effluent, thus protecting the river nearby at an affordable cost. Capital costs for RSFs range from \$3 to \$10 per treated gallon. The annual operating costs are very low. For example, at Elkton, the annual O&M cost for the RSF is less than \$5,000, which includes \$780 for electricity.

Use of a smaller media (< 3.0 mm) would have resulted in better nitrification, but this was not a concern when the design was made.

**TABLE 2 ELKTON'S RSF EFFLUENT QUALITY DATA**

<b>Wastewater Characteristics</b>	<b>Influent (mg/L)</b>	<b>Effluent (mg/L)</b>
BOD	123	4
TSS	37	9
NH <sub>3</sub> -N	51	10
NO <sub>3</sub> -N	2	26

Source: Orenco Systems, Inc., 1998.

## **ADVANTAGES AND DISADVANTAGES**

### **Advantages**

- No chemicals are required.
- RSFs provide a very good effluent quality with over 95% removal of biochemical oxygen demand (BOD) and total suspended solids (TSS).
- The treatment capacity can be expanded through modular design.
- RSFs are effective in applications with high levels of BOD.
- RSFs are easily accessible for monitoring and do not require a lot of skill to maintain.
- A significant reduction in the nitrogen level is achieved.
- If sand is not feasible, other suitable media could be substituted that may be found locally.
- Less land area is required (1/5 of the land area of a single-pass sand filter) for RSFs than for single-pass sand filters.

### **Disadvantages**

- If appropriate media are not available locally, costs could be higher.
- Weekly maintenance is required for the media, pumps, and controls.
- Design must address extremely cold temperatures.

## **DESIGN CRITERIA**

The RSF system is an open sand filter with a sand media depth of 2 feet. A layer of graded gravel (about 12 inches) is provided under the sand for support to the media and to surround the underdrain system. A portion of the mixture (septic tank effluent and sand filtrate) is dosed by a submersible

pump through a distribution system that applies it evenly over the sand filter. The dosing frequency is controlled by a programmable timer in the control panels.

The filtrate from the sand filter is collected by underdrains that are located at the bottom of the bed. The filter discharge line passing through the recirculation tank is located near the top of the tank.

Figure 1 shows a ball float valve connected to a downturned "T" on the discharge line, in which is housed a rubber ball with a diameter slightly larger than that of the pipe. As the filter effluent rises in the tank, it forces the rubber ball firmly against the bottom of the downturned leg, thus discharging the effluent for further treatment or disposal. Other control mechanisms may be used, but care must be taken to ensure that the recirculation tank does not run dry.

Table 3 gives typical design specifications for RSFs.

In very cold climates, the RSF design must include elements that prevent freezing of standing water. Distribution lines must drain between doses and tanks, and the filter should be insulated.

## PERFORMANCE

RSFs produce a high quality effluent with approximately 85% to 95% BOD and TSS removal. In addition, almost complete nitrification is achieved. Denitrification also has been shown to occur in RSFs. Depending on modifications in design and operation, 50% or more of applied nitrogen can be removed.

The performance of a RSF system depends on the type and biodegradability of the wastewater, the environmental conditions within the filter, and the design characteristics of the filter. Temperature affects the rate of microbial growth, chemical reactions, and other factors that affect the stabilization of wastewater within the RSFs.

Other parameters that affect the performance and design of RSFs are the degree of wastewater pretreatment, the media size, media depth, hydraulic loading rate, organic loading rate, and dosing

**TABLE 3 TYPICAL DESIGN CRITERIA FOR RSFS**

Item	Design Criteria
Pretreatment	Minimum level: septic tank or equivalent
Filter medium	
Material	Washed durable granular material
Effective size	1.0 to 3.0 mm
Uniformity coefficient	< 4.0
Depth	24 in
Underdrains	
Type	slotted or perforated pipe
Slope	0 - 0.1%
Bedding	Washed durable gravel or crushed stone (0.25 - 1.50 in)
Hydraulic loading	3.0 to 5.0 gpd/ft <sup>2</sup> / (forward flow)
Organic loading	0.002 - 0.008 lb/ft <sup>2</sup> /day
Recirculation ratio	3:1 to 5:1
Recirculation tank	Volume equivalent to at least 1 day's raw wastewater flow
Distribution and dosing system	Pressure-dosed manifold distribution system and spray nozzles where permitted
Dosing	
Time on	< 2-3 minutes
Time off	Varies
Frequency	48-120 times/day or more
Volume/orifice	1-2 gal/orifice/dose

Source: Adapted from Crites and Tchobanoglous with permission from The McGraw-Hill Companies, 1998.

techniques and frequency.

The effectiveness of a granular material as filter media is dependent on the size and uniformity of the grains. The size of the granular media affects how

much wastewater is filtered, the rate of filtration, the penetration depth of particulate matter, and the quality of the filter effluent. The finer the grain, the slower the rate and higher the quality of the effluent.

High hydraulic loading rates are typically used for filters that receive higher quality wastewater. The accumulation of organic material in the filter bed affects the performance of RSFs. As with hydraulic loading, an increase in the organic loading rate results in shorter filter life.

## OPERATION AND MAINTENANCE

RSFs require routine maintenance, although the complexity of maintenance is generally minimal. Primary O&M tasks include monitoring the influent and effluent, inspecting the dosing equipment, maintaining the filter surface, checking the discharge head on the orifices, and flushing the distribution manifold annually. The surface of the sand bed should be kept weed free.

In addition, the septic tank should be checked for sludge and scum buildup and pumped as needed. The recirculation tank should also be inspected and maintained.

The pumps should be installed with quick disconnect couplings for easy removal. A duplicate recirculation pump should be available for backup. Listed in Table 4 are the typical O&M requirements for RSFs.

## COSTS

The cost of RSFs depends on the labor, materials, site, capacity of the system, and characteristics of the wastewater. One of the most significant factors that affects the cost of sand filters is media cost. Therefore, using locally available materials for the media is usually the most cost-effective option.

Table 5 shows the costs for RSFs with sand media and black beauty sand media used in a facility treating 5,000 gpd. These are typical costs, actual costs will vary from site to site and among different designs. Local regulatory requirements and labor rates will affect cost as well. The cost data in Table 5 includes the labor and machinery necessary to

**TABLE 4 RECOMMENDED O&M FOR RSFS**

Item	O&M Requirement
Pretreatment	Depends on process; remove solids from septic tank or other pretreatment unit
Dosing chamber	
Pumps and controls	Check every 3 months
Timer sequence	Check and adjust every 3 months
Appurtenances	Check every 3 months
Filter media	If continuous hydraulic or biological overloading occurs, the top portion of the media can clog and may need to be replaced if not corrected in time
Other	Weed as needed
	Monitor/calibrate distribution device as needed
	Prevent ice sheeting

Source: U.S. Environmental Protection Agency, 1980.

install media, plumbing, and tankage in the excavation and landscape, the same should be noted for the recirculation tank (minus the media).

The cost of the pretreatment unit(s) for a RSF system will depend on the waste stream characteristics specific to the site application. Effluent sewer systems incorporate individual or community septic tanks to pretreat wastewater before it flows into the recirculation tank. Developments that include commercial establishments may require higher levels of pretreatment in the form of additional septic tank storage, surge capacity, grease traps, and possibly aerobic digestion.

Suggested maintenance for RSFs range from weekly inspections (15 to 30 minutes) to monthly inspections (for approximately 1 hour).

The Ashco Rock Filter Storage II (RFSII) sand filters consists of three different gradations of

media; high spec black beauty sand, Ashco's Bottom Zone, and spray grids with spray nozzles to distribute the recycled filtrate evenly over the media, all contained in 75 square foot precast concrete cells.

**TABLE 5 COST ESTIMATES FOR A 5,000 GPD FACILITY USING TWO DIFFERENT MEDIA**

Item	Cost (\$)	
	Sand <sup>1</sup>	Black Beauty Sand <sup>2</sup>
<u>Capital Costs</u>		
Construction costs		
Pretreatment	May vary	May vary
Recirculation tank and pumping system	10,000	9,000
Sand filter	10,000 <sup>a</sup>	43,100
Non-component costs		
Engineering	3,000	7,800
Contingencies	3,000	7,800
Land	May vary	May vary
Total Capital Costs	26,000	67,700
<u>Annual O&amp;M Costs</u>		
Labor	20/hr	20/hr
Power	May vary	May vary
Sludge disposal @ 10 cents/gal	50/yr <sup>b</sup>	50/yr <sup>b</sup>

Note: Non-component costs include piping and electrical. Engineering and contingency each equal approximately 15% of construction costs. Costs toward land, labor, and power may be different from site to site and system to system.

<sup>a</sup> Design does not include precast concrete cells.

<sup>b</sup> Average pumping frequency is every 5 years.

Source: (1) Orenco Systems, Inc., 1998. and (2)

## REFERENCES

1. Anderson, D. L.; R. L. Siegrist; and R. J. Otis. 1985. *Technology Assessment of Intermittent Sand Filters*. U.S. Environmental Protection Agency (EPA). Municipal Environmental Research Laboratory. Cincinnati, Ohio.
2. Ball, J. L. and G. D. Denn. 1997. *Design of Recirculating Sand Filters Using a Standardized Methodology*. Site Characterization and Design of Onsite Septic Systems. American Society for Testing Materials. Fredericksburg, Virginia.
3. Crites, R.; C. Lekven; S. Wert; and G. Tchobanoglous. Winter 1997. A Decentralized Wastewater System for a Small Residential Development in California. *The Small Flows Journal*. vol. 3. no. 1.
4. Crites, R. and G. Tchobanoglous. 1998. *Small and Decentralized Wastewater Management Systems*. The McGraw-Hill Companies. New York, New York.
5. Hines, M. and R. E. Favreau. Dec. 9-10, 1974. Recirculating Sand Filter: An Alternative to Traditional Sewage Absorption Systems. *Proceedings of the National Home Sewage Disposal Symposium*. pp. 130-136. Chicago, Illinois.
6. Hines, M. Sept. 29-Oct. 1, 1975. The Recirculating Sand Filter: A New Answer for an Old Problem. *Proceedings of the Illinois Private Sewage Disposal Symposium*. pp. 68-78. Champaign, Illinois.
7. Martin, E. J. and E. T. Martin. 1991. *Technologies for Small Water and Wastewater Systems*. *Environmental Engineering Series*. pp. 285-291. Van Nostrand Reinhold (now acquired by John Wiley & Sons, Inc.). New York, New York.

8. Orenco Systems, Inc. 1998. *Elkton, Oregon: A Case Study*. Orenco Systems, Inc. Sutherlin, Oregon.
9. U.S. Environmental Protection Agency. 1980. *Design Manual: Onsite Wastewater Treatment and Disposal Systems*. EPA 625/1-80-012. EPA Office of Water. EPA Office of Research & Development. Cincinnati, Ohio.

The mention of trade names or commercial products does not constitute endorsement or recommendation for use by the U.S. Environmental Protection Agency.

### **ADDITIONAL INFORMATION**

Infiltrator Systems Inc.  
Technical Sales and Services Department  
P.O. Box 768  
Old Saybrook, CT 06475

Dr. Bruce J. Lesikar, Associate Professor  
Agricultural Engineering Department  
Texas A&M University System  
201 Scoates Hall  
College Station, TX 77843-2117

David L. Lindbo  
Assistant Professor, Non-Agricultural Soil Science  
Vernon G. James Research and Extension Center  
NC State University, Dept of Soil Science  
207 Research Station Road  
Plymouth, NC 27962

Anthony Tarquin  
University of Texas at El Paso  
Civil Engineering Department  
El Paso, TX 79968

David Vehuizen, P.E.  
5803 Gateshead Drive  
Austin, TX 78745

For more information contact:

Municipal Technology Branch  
U.S. EPA  
Mail Code 4204  
401 M St., S.W.  
Washington, D.C., 20460