



This document is part of Appendix A, Clean Ballast: Nature of Discharge for the "Phase I Final Rule and Technical Development Document of Uniform National Discharge Standards (UNDS)," published in April 1999. The reference number is EPA-842-R-99-001.

Phase I Final Rule and Technical Development Document of Uniform National Discharge Standards (UNDS)

Appendix A

Clean Ballast: Nature of Discharge

April 1999

NATURE OF DISCHARGE REPORT

Clean Ballast

1.0 INTRODUCTION

The National Defense Authorization Act of 1996 amended Section 312 of the Federal Water Pollution Control Act (also known as the Clean Water Act (CWA)) to require that the Secretary of Defense and the Administrator of the Environmental Protection Agency (EPA) develop uniform national discharge standards (UNDS) for vessels of the Armed Forces for "...discharges, other than sewage, incidental to normal operation of a vessel of the Armed Forces, ..." [Section 312(n)(1)]. UNDS is being developed in three phases. The first phase (which this report supports), will determine which discharges will be required to be controlled by marine pollution control devices (MPCDs)—either equipment or management practices. The second phase will develop MPCD performance standards. The final phase will determine the design, construction, installation, and use of MPCDs.

A nature of discharge (NOD) report has been prepared for each of the discharges that has been identified as a candidate for regulation under UNDS. The NOD reports were developed based on information obtained from the technical community within the Navy and other branches of the Armed Forces with vessels potentially subject to UNDS, from information available in existing technical reports and documentation, and, when required, from data obtained from discharge samples that were collected under the UNDS program.

The purpose of the NOD report is to describe the discharge in detail, including the system that produces the discharge, the equipment involved, the constituents released to the environment, and the current practice, if any, to prevent or minimize environmental effects. Where existing process information is insufficient to characterize the discharge, the NOD report provides the results of additional sampling or other data gathered on the discharge. Based on the above information, the NOD report describes how the estimated constituent concentrations and mass loading to the environment were determined. Finally, the NOD report assesses the potential for environmental effect. The NOD report contains sections on: Discharge Description, Discharge Characteristics, Nature of Discharge Analysis, Conclusions, and Data Sources and References.

2.0 DISCHARGE DESCRIPTION

This section describes the clean ballast discharge and includes information on: the equipment that is used and its operation (Section 2.1), general description of the constituents of the discharge (Section 2.2), and the vessels that produce this discharge (Section 2.3).

2.1 Equipment Description and Operation

Ballast water is carried by many types of vessels and is held in a variety of tanks. The relative complexity of ballast operations depends on the size, configuration, and requirements of the vessel and on the complexity of its pumping and piping systems.

Clean ballast water is seawater which is introduced into dedicated ballast tanks to adjust a vessel's draft, buoyancy, trim and list, and to improve stability under various operating conditions. For example, ballast water is used on various vessel classes to replace the weight of off-loaded cargo or expended fuel oil. Generally, seawater is directed to the ballast tanks from the firemain, by flooding, and/or from dedicated ballast pumps. Ballast intake systems are usually covered with a grate; suction strainers can be used to protect the pumping system from debris. Ballast water is discharged through valves by gravity or pressurized air, or is pumped out by eductors. Clean ballast tanks are dedicated to ballasting operations and their contents are not mixed with fuel or oil.

Amphibious assault ships also flood clean ballast compartments during landing craft operations to lower the ship's stern, allowing the well deck to be accessed. This ballast water is subsequently discharged at the end of the operation. Figure 1 depicts a typical amphibious ship ballast and deballast tank system.

U.S. Navy submarines have main and variable ballast systems. The main ballast system controls the submarine's overall buoyancy while the variable ballast system controls the submarine's trim and list, and adjusts for variations in the submarine's buoyancy while operating submerged.

2.2 Releases to the Environment

Ballast water has the potential to contain plants and animals, including microorganisms and pathogens, that are native to the location where the water was brought aboard. When the ballast water is transported and discharged into another port or coastal area, the surviving organisms have the potential to impact the local ecosystem. Ballast water also has the potential to contain metals and chemical constituents from contact with piping systems and ballast tank coatings. Releases to the environment occur when ballast water is discharged.

2.3 Vessels Producing the Discharge

Ballast water collection and discharge practices depend on vessel class and mission characteristics. Most surface vessels in the Navy have clean ballast systems, including the

following vessel classes: amphibious assault ships (LHD, LHA, LPH), aircraft carriers (CV/CVN), amphibious transport docks (LPD), frigates (FFG), dock landing ships (LSD), oilers (AOE), and amphibious command ships (LCC). All U.S. Navy submarines (SSNs and SSBNs) have main and variable ballast systems.

U.S. Coast Guard (USCG) vessels that have designated seawater ballast tanks include the following classes: medium endurance cutters (WMEC), sea going buoy tenders (WLB), and ice breakers (WAGB).

Most Military Sealift Command (MSC) have clean ballast systems, including the following vessel classes: fleet-support auxiliary ships (T-AFS, T-AE, and T-AO), point-to-point supply ships (T-AKR) and other ships (T-AH, T-AGS, T-AGOS, T-AGOR, T-AG, T-AGM, and T-ATF).¹

Army ships designed for intra-theater cargo transport (LCU-2000 and LSV) take on and discharge clean ballast when loading and unloading cargo and equipment. Vessels of the Air Force also discharge ballast water within 12 nautical miles (n.m.) of shore.

3.0 DISCHARGE CHARACTERISTICS

This section contains qualitative and quantitative information that characterizes the discharge. Section 3.1 describes where the discharge occurs with respect to harbors and near-shore areas, Section 3.2 describes the rate of the discharge, Section 3.3 lists the constituents in the discharge, and Section 3.4 gives the concentrations of the constituents in the discharge.

3.1 Locality

The mode and location of ballast water discharge differs for Navy, USCG, MSC, Army, and Air Force vessels, and also varies among individual ship classes depending on the mission or design of the vessel. Discharge of ballast water is intermittent for vessels of each service. Discharges can occur in port or at sea depending upon service policies and the individual vessel's operational requirements. Ballast water is normally released at sea (outside of 12 n.m.) or in the same general vicinity from which it was taken aboard.

In order to adopt the intent of guidelines established by the International Maritime Organization (IMO), the Navy has instituted a "double-exchange" policy for surface vessels.² All Navy surface vessels completely offload ballast water originating in a foreign port outside of 12 n.m. from shore and take on and discharge 'clean sea water' two times prior to entry within 12 n.m. of shore. The seawater then can be discharged within 12 n.m. of shore whenever ballast is no longer needed.

All submarines submerge by filling externally mounted main ballast tanks (MBTs) and surface by emptying them. Discharges from MBTs happen mainly during surfacing when seawater in MBTs is displaced overboard by air forced into the tanks. The majority of

submarines submerge and surface outside of 12 n.m. of shore, however, submarines on occasion do surface and submerge within 12 n.m. of shore at selected ports where ocean depth and vessel traffic permit this practice. While transiting on the surface from port, variable ballast water can be discharged to make small adjustments to the ship's trim. Once the submarine submerges, the variable ballast system is used as necessary to maintain trim and stability. In port, both main and variable ballast can occasionally be taken on or discharged to support maintenance activities or to compensate for weight changes. Any ballast water taken on by the MBTs in port is discharged prior to leaving port. While visiting foreign ports, submarines avoid taking water into the variable ballast system. If additional variable ballast water is required, submarines take on freshwater to prevent fouling of systems and equipment.

Amphibious ships take on ballast water in coastal waters (within 12 n.m.) during landing craft operations and discharge it at the conclusion of those operations in the same general location.

USCG vessels do not discharge ballast water collected near one coastal area into another coastal area. Coast Guard vessels are required to exchange their ballast water twice beyond 12 n.m. of shore, if the water originated from within 12 n.m.^{3,4}

MSC vessels may discharge clean ballast both at sea and in port. The location of the discharge varies by vessel category. Fleet-support auxiliary ships typically load ballast at sea when discharging cargo and unload ballast near shore when taking on cargo. Point-to-point supply ships typically ballast to replace the weight of consumed fuel, not to compensate for off loaded cargo, and deballast occurs after a voyage, usually in port. The remaining ships of the MSC fleet typically ballast to bring the ship to an appropriate draft and trim for mission requirements. Some of these ships may hold ballast for long periods and others may use freshwater ballast only.¹ Although an official MSC policy has not yet been approved, many MSC vessels currently abide by IMO guidelines, which recommend exchanging ballast water in waters 2,000 meters or more in depth before entering coastal zones.⁵

Navy, USCG, and IMO policies for surface vessels are summarized in Table 1.

3.2 Rate

The volume of seawater discharged during deballasting operations varies by vessel class and activity. Typical ballasting operations on surface ships only use a portion of the total ballast capacity. For example, the average maximum ballast carried by a T-AO 187 Class ship has been reported to be around 50% of capacity, although the actual quantity of ballast varies significantly depending on the quantity of cargo carried.¹

Total capacity of individual ballast systems varies significantly by vessel class. The LSD 41 Class and T-AO 187 Class ships have ballast tanks with a capacity of three million gallons. T-AKR 287 Class ships have a total ballast capacity of approximately 1.2 million gallons, while the MSC oceanographic research ship, USNS Vanguard (T-AG 194), carries approximately 1.7 million gallons of freshwater ballast that is only emptied in dry dock during tank inspections.^{1,6}

Other ship capacities for Navy and USCG vessels are as shown in Table 2.

Deballasting flow rates also vary significantly by vessel class. Deballasting methods include gravity fed systems, eductor systems, or compressed air pumps with associated drain valves. Typical air compressors that pressurize and empty ballast tanks on board amphibious ships are rated for 2,000 standard cubic feet per minute (scfm) air flow which is sufficient to displace an equivalent of 14,960 gallons per minute (gpm) of ballast water. Main ballast tanks on submarines are typically evacuated within 30 minutes using pressurized air.⁷

3.3 Constituents

Constituents of clean ballast may include material from piping and piping components, coatings, and additives.

Rust inhibitors containing aliphatic petroleum distillates are commonly applied to some MSC ballast tanks. Additional constituents may include flocculant chemicals, composed of 95% water and 5% salts and polymers.⁸ Flocculant chemicals are introduced in ballast tanks of some MSC vessels to facilitate the discharge of suspended silts during deballasting operations. Sediments frequently accumulate on the bottom and on many horizontal surfaces of ballast tanks and may be discharged during deballasting operations. Lead-block ballast are also present in the ballast tanks on some MSC vessels.

Metals and chemical constituents can be introduced to ballast water through contact with piping systems and ballast tank coatings. Constituent loadings are expected to increase with increased residence time of water in the clean ballast systems. The composition of piping and components that contact ballast water includes iron, copper, nickel, bronze, titanium, chromium, and composites. These composites are a linen reinforced graphite phenolic compound and reinforced epoxy matrix. Fitting and valve materials include aluminum, copper, nickel, and silver-brazed materials. Synthetic and cloth-rubber gaskets, nitrile seals, and ethylene propylene rubber O-ring seals may also be wetted parts of the ballast system.^{9,10}

The interiors of tanks of Navy vessels are typically coated with epoxy coatings, and the tanks can contain zinc or aluminum anodes for cathodic protection.^{11,12} Ballast tank coating specifications list the following constituents: polyamide, magnesium silicate, titanium dioxide, a solvent, naphtha, and epoxy resin. Specifications also dictate the maximum allowable concentrations of solvents in epoxy coatings.

Firemain systems are used to fill many clean ballast tanks. Although concentrations in firemain discharge cannot be directly correlated with constituent concentrations in clean ballast water, analytical data obtained from sampling of shipboard firemain systems could serve as an indicator of potential constituents introduced to clean ballast water. Based on the make up of clean ballast systems and the analytical results of firemain discharge sampling, the following priority pollutants could be present within the discharge: copper, nickel, and zinc. No bioaccumulators are known or suspected to be present in clean ballast discharge.

3.4 Concentrations

Although suspected constituents in clean ballast discharge have been identified, constituent concentrations were not estimated.

4.0 NATURE OF DISCHARGE ANALYSIS

Based on the discharge characteristics presented in Section 3.0, the nature of the discharge and its potential impact on the environment can be evaluated. Mass loadings are discussed in Section 4.1 and the concentrations of discharge constituents after release to the environment are discussed in Section 4.2. In Section 4.3, the potential for the transfer of non-indigenous species is discussed.

4.1 Mass Loadings

Using known tank volumes and numbers of vessels in specific classes, an estimate of the total ballast capacity is presented in Table 2. Most surface vessels are required to conduct double exchanges outside of 12 n.m. of shore unless the discharge of the clean ballast is located in the same geographical region as the intake, or operational conditions prevent the double flush from being performed. Additional ballast exchanges occur within 12 n.m. Although total ballast capacity estimates have been made, mass loading of chemical constituents were not estimated due to the uncertainty in the frequency of ballasting operations and the lack of chemical constituent data.

4.2 Environmental Concentrations

Although water quality criteria are available for suspected constituents, no analyses have been completed and constituent concentrations are not available. A comparison of concentrations with water quality criteria was not made.

4.3 Potential for Introducing Non-indigenous Species

Discharged clean ballast water from vessels of the Armed Forces has potential for introducing non-indigenous species into receiving waters. This can be inferred from studies of commercial vessels.

Studies of foreign ballast water commonly introduced into the Chesapeake Bay found that more than 90% of the commercial vessels carried live organisms. Forty percent of the sampled vessels had organisms within their ballast tanks including dinoflagellates and diatoms. Such organisms are suspended in both water and sediments within ballast tanks. Organisms also may attach to tank walls and be dislodged during deballasting.¹³ One study characterized a variety of non-indigenous species in 159 cargo vessels arriving in Coos Bay, Oregon, from 25 different Japanese ports. The study found 367 distinctly identifiable taxa, representing 16 animal phyla, 3 protist phyla, and 3 plant divisions. Organisms present in most vessels included copepods (99%

of vessels), polychaete worms (89%), barnacles (83%), clams and mussels (71%), flatworms (65%), crabs and shrimp (48%), and chaetognaths (47%).¹³

The preliminary conclusion of a Smithsonian Environmental Research Center (SERC) study of three Navy surface ships' ballast water during transit of the Atlantic is that the double-exchange of ballast water can be a "very effective" method of preventing the introduction of non-indigenous species. The SERC study performed a double-exchange of clean ballast water containing a known number/concentration of microbials and found that 95% to 100% of the microbials were removed.¹⁴ The SERC study noted that a "large number" of the microbials would not have survived the transit even if the double exchange of ballast water had not been performed. Therefore, the percentage reduction of the number or type of non-indigenous species transported in the ballast water of Navy surface vessels achieved by double-exchange has not been determined.

Although the presence of non-indigenous species has been verified by previous studies of commercial vessels, exact densities of individual species introduced through deballasting operations of vessels of the Armed Forces have not been evaluated.

5.0 CONCLUSION

Clean ballast discharges have a potential to cause an adverse environmental effect because clean ballast water has the potential for transferring non-indigenous species between ports.

6.0 DATA SOURCES AND REFERENCES

To characterize this discharge, information from various sources was obtained. Process information, equipment specifications, and research concerning non-indigenous species was used. Table 3 shows the sources of data used to develop this NOD report.

Specific References

1. Weersing, Penny, Point Paper - Supplemental Information about Ballast Water - MSC Ships. 31 October 1996.
2. Department of the Navy, Office of the Chief of Naval Operations. Summary Matrix of OPNAVINST 5090.1B, Environmental and Natural Resources Program Manual, Chapter 19-10 (Ship Ballast Water and Anchor System Sediment Control Requirements). 1 November 1994.
3. Directive Order. COMLANTAREA COGARD, Portsmouth, VA to LANT CUTTER FLT. Ballast Water Exchange Program, 14 August 1996.

4. Directive Order. COMPACAREA COGARD, Alameda, CA. PACAREA Aquatic Prevention Program, 12 November 1996.
5. Weersing, Penny, Attachment 4, Point Paper - Supplemental Information about Ballast Water - MSC Ships. Summary Matrix of OPNAVINST 5090.1B. 31 October 1996.
6. UNDS Equipment Expert Meeting Minutes - Clean Ballast. 18 September 1996.
7. Letter from Commander Submarine Force, U. S. Atlantic Fleet to Commander, Naval Sea Systems Command (00T); Ser N451A/4270 dated 13 Dec 1996; COMSUBLANT Response to UNDS Data Call; 688 Class and 726 Class Submarine Discharge Data Package.
8. Ashland Chemical Company. Material Safety Data Sheets - Magnakote Rust Preventative and Mud Conditioner. 8 February 1995 and 10 February 1995.
9. Mil. Spec. MIL-P-83461, "Packings, Preformed, Petroleum Hydraulic Fluid Resistant, Improved Performance at 275°F (135°C)".
10. Mil. Spec. MIL-G-22050, "Gasket and Packing Material, Rubber for Use With".
11. Mil. Spec. MIL-P-24441, "Paint, Epoxy-Polyamide, General Specification For".
12. Mil. Spec. MIL-PRF-23236, "Paint Coating Systems, Fuel and Salt Water Ballast Tank".
13. Chesapeake Bay Commission. The Introduction of Nonindigenous Species to the Chesapeake Bay Via Ballast Water - Strategies to Decrease the Risks of Future Introductions through Ballast Water Management. 5 January 1995.
14. Ruiz, Greg. Non-Indigenous Species Presentation - Notes by Dan G. Mosher, Malcolm Pirnie, Inc. 18 September 1996.
15. International Maritime Organization (IMO). Guidelines for Preventing the Introduction of Unwanted Aquatic Organisms and Pathogens from Ships' Ballast Water and Sediment Discharges, 10 May 1995

General References

USEPA. Toxics Criteria for Those States Not Complying with Clean Water Act Section 303(c)(2)(B). 40 CFR Part 131.36.

USEPA. Interim Final Rule. Water Quality Standards; Establishment of Numeric Criteria for Priority Toxic Pollutants; States' Compliance – Revision of Metals Criteria. 60 FR 22230. May 4, 1995.

- USEPA. Water Quality Standards; Establishment of Numeric Criteria for Priority Toxic Pollutants. 57 FR 60848. December 22, 1992.
- USEPA. Water Quality Standards; Establishment of Numeric Criteria for Priority Toxic Pollutants for the State of California, Proposed Rule under 40 CFR Part 131, Federal Register, Vol. 62, Number 150. August 5, 1997.
- Connecticut. Department of Environmental Protection. Water Quality Standards. Surface Water Quality Standards Effective April 8, 1997.
- Florida. Department of Environmental Protection. Surface Water Quality Standards, Chapter 62-302. Effective December 26, 1996.
- Georgia Final Regulations. Chapter 391-3-6, Water Quality Control, as provided by The Bureau of National Affairs, Inc., 1996.
- Hawaii. Hawaiian Water Quality Standards. Section 11, Chapter 54 of the State Code.
- Mississippi. Water Quality Criteria for Intrastate, Interstate and Coastal Waters. Mississippi Department of Environmental Quality, Office of Pollution Control. Adopted November 16, 1995.
- New Jersey Final Regulations. Surface Water Quality Standards, Section 7:9B-1, as provided by The Bureau of National Affairs, Inc., 1996.
- Texas. Texas Surface Water Quality Standards, Sections 307.2 - 307.10. Texas Natural Resource Conservation Commission. Effective July 13, 1995.
- Virginia. Water Quality Standards. Chapter 260, Virginia Administrative Code (VAC) , 9 VAC 25-260.
- Washington. Water Quality Standards for Surface Waters of the State of Washington. Chapter 173-201A, Washington Administrative Code (WAC).
- National Research Council. Stemming the Tide, Controlling Introductions of Nonindigenous Species by Ship's Ballast Water. National Academy Press, 1996.
- Aivalotis, LT Joyce. UNDS Info, 18 February 1997, Doug Hamm, Malcolm Pirnie, Inc.
- Naval Sea Systems Command (NAVSEA). Ship Information Book, S9CVN-CD-SIB-020, CVN 70 Vol. 2, Pt. 1, Bk 1, Chapter 11, Drainage and Ballasting Systems, Section 3, Sea Water Ballasting System.
- Naval Sea Systems Command (NAVSEA). Ship Information Book, S9LHA-AA-SIB-020, LHA 1, Section 7-41, Ballast/Deballast System.

Naval Sea Systems Command (NAVSEA). Ship Information Book, 0905LP-123-6010, LCC 19, Section 2, Chapter 1, Fuel Oil Tank Stripping and Clean Ballast Systems.

Naval Sea Systems Command (NAVSEA). Ship Information Book, S9LHD-AA-SIB-060, LHD 1, Chapter 14, Ballast/Deballast System.

Naval Sea Systems Command (NAVSEA). Ship Information Book, S9LPD-AD-SIB-020, LPD 4, Vol. 2, Pt. 1, Table 7-2, Approximate Time to Ballast & Deballast Tanks.

Naval Sea Systems Command (NAVSEA). Ship Information Book, S9LSD-BH-SIB-100, LSD 41, Vol. 7, Ballasting/Deballasting.

Columbia/HCA Healthcare Corporation. Epidemic Cholera in the New World: Translating Field Epidemiology into New Prevention Strategies. 2 October 1996.

Krotoff, Oleg, Ashland Chemical. Conversation with Oleg Krotoff, Env. Engineer, Ashland Chemical, 13 May 1997, Doug Hamm, Malcolm Pirnie, Inc.

UNDS Equipment Expert Meeting Round Two - Clean Ballast. 15 April 1997.

Weersing, Penny, MSC. UNDS: Clean Ballast, 15 May 1997, Doug Hamm, Malcolm Pirnie, Inc. UNDS Equipment Expert Meeting - Clean Ballast. 18 September 1996, M. Rosenblatt & Son, Inc.

Committee Print Number 95-30 of the Committee on Public Works and Transportation of the House of Representatives, Table 1.

The Water Quality Guidance for the Great Lakes System, Table 6A. Volume 60 Federal Register, p. 15366. March 23, 1995.

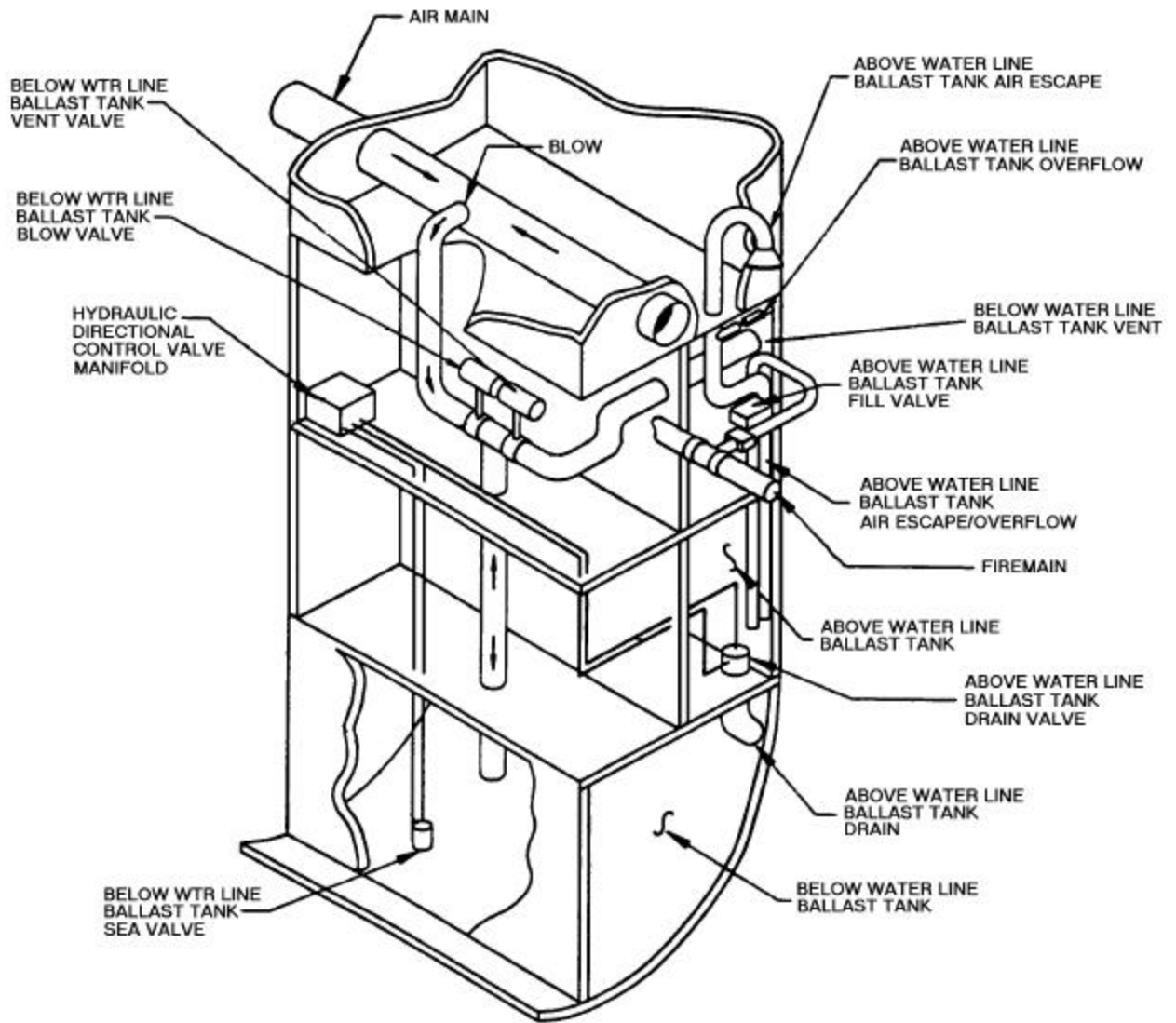

Figure 1. Typical Amphibious Ship Ballast and Deballast Tank Piping Composite

Table 1. Summary of IMO, USCG, and Navy Exchange Policies for Clean Ballast Water From Surface Vessels

NAVY ²	USCG ^{3,4}	IMO ¹⁵
Requires potentially polluted ballast water to be offloaded outside of 12 n.m. from shore and clean sea water taken on and discharged twice prior to entry within 12 n.m. from shore.	Requires potentially polluted ballast water to be offloaded outside of 12 n.m. from shore and clean sea water taken on and discharged twice prior to entry within 12 n.m. from shore.	Recommends ballast water exchange to take place in areas with a depth of 2000 meters or more to minimize the introduction of non-indigenous invasive species.
Requires entering records of ballast water exchanges and their geographical location in ship's engineering log.	Requires entering records of ballast water exchanges and their geographical location in ship's engineering log.	Recommends record keeping of ballast water exchange, sediment removal, procedures used, and appointment of responsible officer on board ships to ensure procedures are followed and records maintained.

Table 2. Estimate of Total Ballast Capacity*

Vessel Class	Service	Ballast Capacity (Gallons)	# Vessels	Total Capacity (Gallons)
T-AO 187	MSC	3,000,000	12	36,000,000
T-AKR 287	MSC	1,200,000	8	9,600,000
T-AG 194	MSC	1,700,000	1	1,700,000
WMEC 270 A&B	USCG	42,250	13	549,250
WLB 225	USCG	92,300	2	184,600
WAGB 399	USCG	115,300	2	230,600
LHA 1	Navy	3,445,867	5	17,229,335
CVN 68	Navy	278,533	7	1,949,731
LCC 19	Navy	593,383	2	1,186,766
LPD 4	Navy	3,700,000	8	29,600,000
LSD 41	Navy	3,090,000	8	24,720,000
LHD 1	Navy	4,000,000	4	16,000,000
AOE 6	Navy	209,941	3	629,823
SSBN 726	Navy	668,904	17	11,371,368
SSN 688	Navy	229,225	56	12,836,600
LSV	Army	403,000	6	2,418,000
LCU-2000	Army	111,369	35	3,897,915
			Total:	170,103,988

Estimate is based upon the largest vessels of the Navy, USCG, MSC, and Army that use clean ballast. Ballast volumes of vessels of the Air Force are not included.

Table 3. Data Sources

NOD Section	Data Source			
	Reported	Sampling	Estimated	Equipment Expert
2.1 Equipment Description and Operation	X			X
2.2 Releases to the Environment	X			X
2.3 Vessels Producing the Discharge	UNDS Database			X
3.1 Locality				X
3.2 Rate				X
3.3 Constituents				X
3.4 Concentrations			N/A	
4.1 Mass Loadings			N/A	
4.2 Environmental Concentrations			N/A	
4.3 Potential for Introducing Non-Indigenous Species	X			X