

Conceptual Site Design for Sustainable Redevelopment
Green Avenue Sites, Greenville, SC

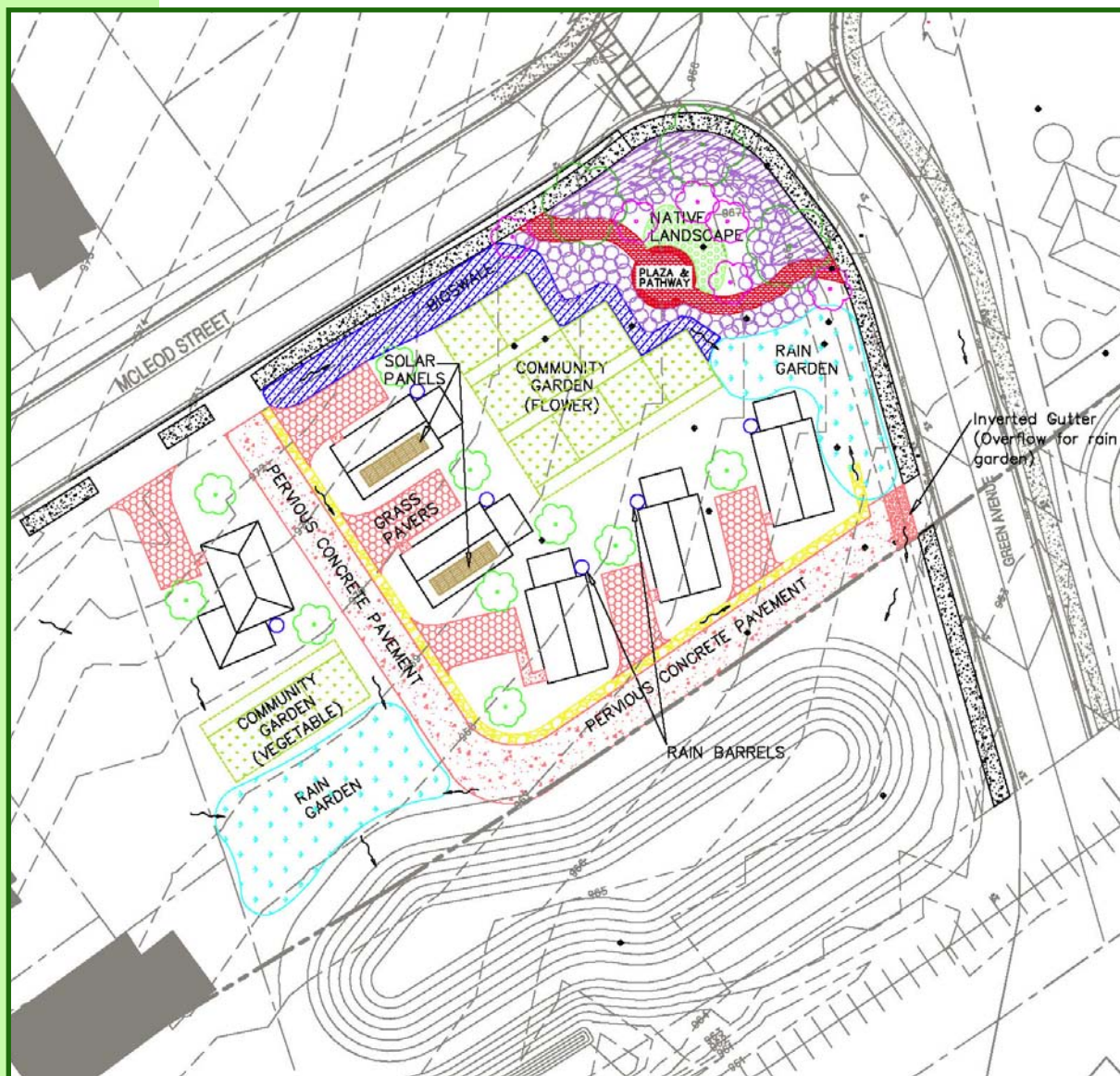

**GREEN AVENUE SITES, GREENVILLE, SC
CONCEPTUAL SITE DESIGN FOR SUSTAINABLE REDEVELOPMENT
BROWNFIELDS SUSTAINABILITY PILOT
TECHNICAL MEMORANDUM**

Prepared for:

*U.S. Environmental Protection Agency
Office of Solid Waste and Emergency Response
Office of Brownfields and Land Revitalization
Washington, DC 20460*

Prepared by:

*Tetra Tech EM Inc.
1881 Campus Commons Dr.
Ste. 200
Reston, VA 20191*

*SRA International, Inc. (Contract No. EP-W-07-023)
3434 Washington Boulevard
Arlington, VA 22201*

TECHNICAL MEMORANDUM
CONCEPTUAL DESIGN FOR SUSTAINABLE REDEVELOPMENT
BROWNFIELDS SUSTAINABILITY PILOT
GREEN AVENUE SITES, GREENVILLE, SC

INTRODUCTION

The U.S. Environmental Protection Agency (EPA) Brownfields Program enables local communities to assess, safely clean up, and sustainably reuse brownfields through collaboration with relevant stakeholders. Under this program, EPA’s Brownfields Sustainability Pilots are providing technical assistance on sustainability practices to help communities achieve greener, more sustainable assessment, cleanup, and redevelopment at their brownfield projects. EPA selected the Green Avenue Sites in Greenville, South Carolina, where a small-scale, affordable workforce housing redevelopment is planned as a Brownfields Sustainability Pilot. As part of this pilot, Tetra Tech EM Inc. (Tetra Tech), through a subcontract to SRA International, Inc., provided technical assistance to the City of Greenville, Office of Economic Development, to integrate green building and sustainable design features into a conceptual site plan. Based on the City’s site redevelopment goals, this site plan and the associated “green” features will (1) allow for sustainable and healthier living in an affordable workforce housing development; (2) help reduce or eliminate stormwater discharges and associated impacts from the development into the city’s stormwater infrastructure; and (3) provide a showcase and design template that promotes sustainable redevelopment opportunities elsewhere in the City of Greenville and that can be replicated on similar sites.

This technical memorandum briefly describes the site and proposed conceptual site plan, indicates conceptual design considerations, specifies recommended green and sustainable features, and offers other recommendations. The conceptual design drawings prepared as part of this pilot are included in Attachment A. Environmental information available for the site and a map of the City’s groundwater monitoring well locations are included in Attachment B.

SITE DESCRIPTION

The Green Avenue Sites redevelopment is an approximately 1-acre brownfield site located in the Green Avenue neighborhood on the south corner of the McLeod Street and Green Avenue intersection, 1 mile southwest of downtown Greenville, South Carolina. The area is characterized by a mix of low-income residential housing and service-related commercial development.

The site was formerly a BP service station with an area of 0.46 acre combined with an adjacent Thriftway supermarket with an area of 0.56 acre. The BP service station had been operating since 1964 and consisted of a service garage, station, fuel oil dispenser island, nine underground storage tanks (UST) for petroleum fuel products, an above-ground storage tank (AST), parking areas, and office building. The USTs and AST were upgraded in 1997, taken out of service in 2002, and removed from the site in 2009. The Thriftway supermarket, with a 6,250-square-foot building, also operated since the 1960s. The building floor tile, exterior shingles, and ceiling tiles contained asbestos.

The site is currently vacant, and both properties have been demolished. The City of Greenville completed a Phase I Environmental Assessment of the site in November 2002, soil sampling in December 2006, and groundwater sampling in February 2007. Groundwater depth at the site was measured as approximately 26 feet below ground surface (bgs) by Midlands Environmental Consultants, Inc. (MECI), in February 2007 (see Attachment B). Groundwater samples were collected at the site from 18 monitoring wells located within the property boundary and at the neighboring property on the east side of Green Avenue. Several contaminants of concern were found, including benzene/toluene/ethylbenzene/xylenes (BTEX), methyl tertiary-butyl ether (MTBE), ethylene dibromide (EDB), and naphthalene. Concentrations above detection limits were localized, with a significantly high concentration of 26,000 micrograms per liter ($\mu\text{g/L}$) for MTBE found at one sampling location on the site near Green Avenue (see Attachment B). Soil samples were collected at the site in December 2006 from 16 to 37 feet bgs and analyzed for BTEX and MTBE. BTEX field screening results ranged from 5.5 to 621 $\mu\text{g/L}$, and MTBE results ranged from 5 to 9,700 $\mu\text{g/L}$. Several field screening soil samples were located at dry holes and others were found to be below detection limits for BTEX and MTBE (MECI 2007), as shown in Attachment B. Based on information provided by the City of Greenville, the selected remedy for any contaminants at the site will be monitored natural attenuation.

Tetra Tech conducted a site visit in May 2009 to observe existing conditions at the site, make additional field observations, and meet with the City of Greenville, Office of Economic Development. According to the proposed city infrastructure maps and other information provided by the City, approximately 0.36 acre of the 1-acre vacant lot will be dedicated to a dry pond to serve the City's stormwater infrastructure. Based on field observations and topographic maps, the site slopes to the east with an average 4 percent grade, and at the time of the visit, had a bare ground surface. The only structures on the site were two light poles and several monitoring wells located throughout the site.

CONCEPTUAL DESIGN CONSIDERATIONS

Three major design considerations were taken into account during the conceptual design of the green and sustainable features for the Green Avenue Sites. These design considerations include the City of Greenville's proposed infrastructure improvements, the City's site development goals and zoning requirements, and groundwater monitoring requirements. They are discussed below.

Infrastructure Improvements

The City of Greenville has proposed a dry pond for its stormwater infrastructure in the south part of the vacant lot, reducing the available lot size for redevelopment to 0.64 acre. When developing green and sustainable features for the project, Tetra Tech considered the lot size limitations and the ability to drain excess runoff into the proposed dry pond.

Other features associated with city infrastructure improvements at the site that were considered during the conceptual design include realignment of the intersection at McLeod Street and Green Avenue with new curbs and sidewalks, a new stormwater conveyance system, and expansion of sanitary sewer lines. These infrastructure improvements are shown on Sheet 2 of Attachment A. As discussed with the City of Greenville, the proposed conceptual site plan for the Green Avenue Sites incorporates the city infrastructure improvements without any modifications.

Development Goals and Zoning Requirements

As recommended by the City of Greenville, the Green Avenue Sites will be developed with single-family detached housing. The City has prepared preliminary design drawings for a similar site on the Bell Furniture Site, which is located across Green Avenue to the northeast. The City suggested a site plan layout similar to the Bell Furniture Site for developing the Green Avenue Sites project. Specific elements

of the Bell Furniture Site suggested for incorporation into the Green Avenue Sites conceptual site plan include a designated public plaza and pathway at the corner of McLeod Street and Green Avenue, stock plans for approximately 1,000-square-foot detached houses, and an adjacent parking space for each house.

The City's zoning requirements for property development were also considered. These requirements include (1) a minimum setback distance of 25 feet from the edge of curb to the house and (2) a minimum width of 15 feet for the access road within the development. Other city standard setbacks within the project are not applicable to this development.

Groundwater Monitoring Requirements

Based on available sampling results (MECI 2007) and information provided by the City of Greenville, the selected remedy for groundwater contamination at the site will be monitored natural attenuation. The City is currently monitoring the site using approximately 18 wells located in the 0.64-acre property; the wells must remain in place for future groundwater monitoring requirements. The structural components of the proposed conceptual site plan were designed and located around the well locations to allow for easy access during future monitoring activities. Locations of the monitoring wells at the site are shown in Attachment B.

PROPOSED CONCEPTUAL SITE PLAN

Based on the conceptual design considerations explained above and in support of the City's site redevelopment goals, Tetra Tech has designed a conceptual redevelopment site plan for the Green Avenue Sites (see Attachment A). This plan includes six detached, single-family houses in an urban setting and overlooking green space specifically designed to provide sustainable and environmentally friendly living. Each house has two levels within approximately 1,000 square feet, and one assigned parking space. Access to the proposed site development is provided via Green Avenue and McLeod Street.

Major green and sustainable features of the site plan include community gardens, a passive park with a plaza and native landscape, rain gardens, a bioswale, infiltration trenches, filter strips, pervious paving, rain barrels, and solar panels. Porches, open to the community garden and park, provide opportunities for outdoor living and a connection with the surrounding neighborhood. The recommended green and

sustainable features of the proposed conceptual plan are described further in the following section. The extent to which these features can be incorporated into the final project will depend on the ultimate site configuration, as well as economic feasibility.

RECOMMENDED GREEN AND SUSTAINABLE FEATURES

Taking into account the design considerations described above, potential green and sustainable design features were identified and incorporated into the conceptual site plan for the Green Avenue Sites. Based on discussions with the City of Greenville, the proposed green and sustainable features are primarily intended to help reduce or eliminate stormwater discharges and associated impacts from the development, minimize impervious area, and maximize stormwater infiltration where possible. These objectives are achieved by capturing runoff at the source and distributing it to a number of low-impact development (LID) practices located throughout the site or into the ground. In addition, some of the proposed green features encourage sustainability and provide for affordable living by (1) reducing energy use and associated costs, (2) reducing water consumption and associated costs, and (3) providing community space for cultivating flowers and household produce.

These “green” features are discussed below, and their proposed locations for implementation at the site are shown in Attachment A on Sheet 3. The features proposed are concepts based on available information; therefore, these features and their locations might need alteration as part of detailed engineering and site design to ensure their continued appropriateness and the stormwater capacity required for this redevelopment.

- ***Erosion and Sediment Control Practices:*** Erosion and sediment control measures should be applied throughout the site during construction activities to reduce negative impacts on water and air quality. Silt fences, a stabilized construction entrance, dust control, temporary seeding, and erosion control blankets are some of the measures recommended by the South Carolina Storm Water Management BMP Handbook (South Carolina Department of Health and Environmental Control [DHEC] 2005).
- ***Infiltration Trenches and Filter Strips:*** Infiltration trenches are linear stormwater best management practices (BMP) consisting of a continuously perforated pipe at a minimum slope in a stone-filled trench. An infiltration trench can be part of a stormwater conveyance system, designed so that runoff from large storm events is conveyed through the pipe with some volume reduction. During small storm events, volume reduction may be significant, with little or no discharge from the trench. Infiltration trenches should be designed with an overflow that allows discharge into a downstream structure or another BMP. Infiltration trenches are more effective

and have longer lives when they include some form of pretreatment such as vegetated filter strips (EPA 1999).

Infiltration trenches can be used at the Green Avenue Sites along the access roads to catch excess stormwater, as shown on Sheet 3 of Attachment A. Curb and gutter should be excluded from the access road design to allow for excess runoff to drain directly into the infiltration trench. Filter strips could also be used in combination with infiltration trenches; however, space is limited at the Green Avenue Sites and only smaller segments of filter strip would be possible. Sheet 4 in Attachment A shows a typical detail of an infiltration trench.

- **Pervious Pavement:** Use of pervious pavement provides water quality and quantity benefits by reducing runoff and attenuating flows during small storm events. Pervious pavement consists of a pervious surface course underlain by a stone bed of uniformly graded and clean aggregate with a void space of at least 40%. Different types of pervious pavement include pervious asphalt, pervious concrete, and pervious pavement units (pavers). Stormwater draining through the pervious surface is temporarily held in the voids of the stone bed, and then slowly drains into the underlying, uncompacted soil mantle.

Pervious pavement can be used at the Green Avenue Sites on access roads, parking areas, and sidewalks. Sheet 3 in Attachment A shows potential locations of pervious pavement at the site. Details of two types of pervious pavement are shown on Sheet 4 in Attachment A. Pervious concrete is recommended on access roads and sidewalks because, in addition to reducing runoff, pervious concrete has a high reflectance index that helps reduce heat island effects - thus saving homeowner energy costs. For parking spaces and pathways, permeable pavers are suggested as they are aesthetically pleasant and encourage more infiltration into the ground. Two types of paver surfaces that could be used at the site include interlocking concrete pavers and grass pavers. Typical details of these types of pavers are shown on Sheet 4 of Attachment A. Access road dimensions shown in the conceptual drawings follow the overall design guidelines for alleys (City of Greenville 2008). The minimum one-way pavement width is 10 feet with an additional right-of-way width of 5 feet where the infiltration trench or filter strip can be located.

- **Rain Gardens:** A rain garden is a natural or constructed depression in the ground used as a landscape feature to manage stormwater and improve water quality (City of Greenville 2007). Rain gardens form a bioretention area that manage and treat stormwater runoff by using a conditioned planting soil bed and planting materials to filter runoff stored within the shallow depression and allow it to slowly percolate into the soil. Bioretention provides good options for water quality BMPs on all sites, including brownfields. Bioretention should be considered on brownfield sites where soil contaminants have been removed during remediation, or where only non-soluble contaminants remain. Potential locations of rain gardens for the Green Avenue Sites are shown on Sheet 3 of the conceptual drawings. A typical design detail of a rain garden is included on Sheet 4 of Attachment A.
- **Bioswales:** A bioswale is another type of bioretention that captures, treats, and slowly releases stormwater runoff volume from a drainage area. Stormwater percolates into the soil or is slowly directed to a rain garden. A bioswale consists of a vegetated channel with a filter bed of prepared soil that overlies an underdrain system where soil infiltration capacity is minimal. Bioretention provides good options for water quality BMPs on all sites, including brownfield sites where soil contaminants have been removed during remediation, or where only non-

soluble contaminants remain. A potential location for a bioswale at the Green Avenue Sites is shown on Sheet 3 of the conceptual drawings. The proposed bioswale located along the community garden would collect stormwater runoff from house backyards, adjacent road, and the community garden, as well as stormwater overflow from the rain barrels. This bioswale would slowly convey stormwater to the rain garden located to the east. A typical design detail of a bioswale is included on Sheet 4 of Attachment A.

- **Rain Barrels:** Rain barrels are rain catchment and storage units that capture rain from rooftops by directing the downspouts to the rain barrels. Rain barrels at the Green Avenue Sites could be placed in the back corners of the houses or parking spaces. The shapes and sizes of rain barrels require very little land area, and these BMPs can be placed in inconspicuous locations; they are also available in decorative designs. Water collected this way can be re-used for non-potable applications such as drip irrigation, lawn sprinkling, toilet flushing, and recreational water.
- **Community Gardens:** A community garden is a designated piece of land gardened by a group of people from the same community. Community gardens can be used to grow flowers or vegetables, and may consist of one community plot or several individual plots. Community gardens improve quality of life in several ways: they stimulate social interaction, beautify neighborhoods, produce nutritious food, reduce family food costs, conserve natural resources, create opportunities for recreation, and reduce local heat island effects. Two community gardens are proposed for the Green Avenue Sites, one community garden with nine individual plots designated for growing flowers and another community garden with three individual plots designated for growing vegetables. Individual plots measuring 15 by 15 feet, each with a 4-foot wide access path, are proposed for the Green Avenue Sites, as shown on Sheet 3 of Attachment A. Alternative uses for the space shown as community garden include a recreational park (playground) for children or native landscaping, which would also improve the quality of life.
- **Solar panels:** Solar panels are arrays of photovoltaic cells that use renewable energy from the sun - a clean and environmentally sound means of collecting solar energy in order to power household appliances. Solar panels could be installed on the rooftops of the proposed houses in orientations that maximize direct sun exposure throughout the year (by pointing toward true south). The photovoltaic (PV) array, or solar panels, should be placed in direct sunlight by installing the PV array directly facing the noontime sun for maximum efficiency. In the City of Greenville, for a PV array facing south, the optimum tilt angle is 60 degrees. The size of the PV arrays depends on the power needs. Typical PV array sizes for residential use range from 2 to 5 kilowatts per day.
- **Soil Amendments:** A soil amendment is any material added to the soil to improve its physical properties such as water retention, permeability, water infiltration, drainage, aeration, organic content, and structure. Soils at the site had been significantly altered, and did not appear to contain much organic material during the site visit. Soil amendments such as leaf compost would provide a better environment for roots, especially benefitting the proposed rain gardens, community gardens, public park, and bioswales.
- **Downspout Disconnects:** Disconnecting rooftop drainage from stormwater pipes reduces stormwater flow rates from developed areas by capturing runoff from rooftops and directing it to green and pervious areas where it can filter through vegetation and drain to the rain gardens.

Typical details showing downspout disconnects directed to rain barrels or rain gardens are shown on Sheet 4 of Attachment A.

- **Native Landscaping:** Plants, flowers, and grasses indigenous or native to the region are the most attuned to soil, climate, and water particularities of the area. They thrive with less watering and maintenance than other imported varieties. Native trees, shrubs, and perennials are less stressed than non-native species, less prone to harm from bugs and disease, and less dependent on chemicals such as fertilizers or pesticides. Native landscaping is proposed at the passive park and plaza, as shown on Sheet 3 of Attachment A. Native landscaping could also be utilized as an alternative to the community gardens.
- **Compost Bins:** Compost bins are containers used to decompose organic waste such as yard trimmings and food residuals into material that can be used to fertilize soil. The bins help prevent odor and pests attracted by compost heaps. Providing compost bins for the homes as part of the development would reduce the quantity of waste generated and the associated disposal costs for homeowners. The compost could be used to generate organic material for use in the community garden and native landscape, or as a source of soil amendments.

OTHER RECOMMENDED ACTIVITIES

To facilitate the detailed design and integration of green and sustainable design features for the Green Avenue Sites redevelopment, and to showcase these features, the following additional activities are recommended:

- **Conduct Geotechnical Investigation for Soil Permeability:** According to the Natural Resources Conservation Service (NRCS) Soil Survey Geographic (SSURGO) Database, the soils at the site have been subjected to extensive urban activity and a site-specific soil investigation is required for their identification (NRCS 2005). This geotechnical soil survey should be conducted to determine soil permeability in locations where the LID stormwater infiltration features would be implemented. Design and effectiveness of LID stormwater features depend significantly on the infiltration capacity of the soils. If soil permeability is found to be low, underdrains should be added to the green design features.
- **Sizing Green Features for Stormwater Management:** Site conditions, stormwater goals, and government regulations dictate the minimum size required for the green design features proposed at the Green Avenue Sites. The appropriate size for these structures should be determined during the detailed design phase.
- **Using Site as a Demonstration Project and Monitoring Benefits:** Most green design features proposed for the Green Avenue Sites can be implemented citywide as part of future redevelopment projects. Therefore, this site can serve as a demonstration project. Monitoring the effectiveness of the implemented green design features is essential to determine applicability to similar sites. For example, stormwater flow can be monitored for water quantity (detention storage) after a storm event, and total suspended solids can be monitored for water

quality removal efficiencies. Energy consumption can also be monitored to calculate energy savings.

- **Apply Green Design to Sidewalks and Curbing.** The Green Avenue Site Plan proposes sidewalks and curbing on McLeod and Lincoln Streets (City of Greenville 2001). Using green design alternatives for the proposed new sidewalks and curbing surrounding the Green Avenue Sites will further enhance the neighborhood and minimize stormwater runoff. Use of aesthetically pleasant green features such as curb and gutter cuts, planter boxes, and vegetated curb extensions (that drain road stormwater runoff to green areas) would also enhance the look and feel of the neighborhood.

- When curb and gutter are necessary, the use of frequent curb cuts could be used to divert a portion of the runoff onto vegetated areas. As shown in the photo, 2-foot wide cuts in the curb can help direct runoff away from the road and stormwater conveyance system. Curb cuts, however, should be covered during construction to prevent sediment entry into the vegetated areas.



Source: Emmons & Olivier Resources, Inc (EOR) 2008

- Planter boxes are small, contained vegetated areas that collect and treat stormwater using bioretention through layers of mulch, soil and plant root systems. These contained areas provide stormwater flow attenuation and pollutant removal. When infiltration is not possible due to low soil permeability, underdrains should be installed and connected to a stormwater conveyance system. Planter boxes do not require a large amount of space and add aesthetic appeal to the neighborhood. They could be located between the curb and sidewalk at the Green Avenue Sites.



Source: County of San Diego 2009

- Vegetated Curb extensions are shallow vegetated basins usually located in the street parking lane. Vegetated curb extensions are another example of bioretention where runoff volumes are reduced and peak flows are attenuated by storage and infiltration. In addition, biological and chemical reactions occur in the mulch, soil matrix, and root zone; and pollutants are removed and filtered into the ground.



Source: County of San Diego 2009

REFERENCES

- City of Greenville. 2001. Green Avenue Neighborhood Revitalization Strategy, City of Greenville, South Carolina. Prepared by Community Development and Relations Division.
- City of Greenville. 2007. Greenville Stormwater Management Plan. Prepared by City of Greenville, Public Works Department, Engineering Division.
- City of Greenville. 2008. City of Greenville Design and Specifications Manual.
- City of Greenville. 2009. Code of Ordinances – City of Greenville, South Carolina.
- County of San Diego. 2009. Low Impact Development (LID), County of San Diego Watershed Planning. Presented by Christine A. Sloan. Available online at http://www.projectcleanwater.org/bb/lid_full_presentation.pdf; accessed on June 25, 2009.
- Emmons & Olivier Resources, Inc. (EOR). 2008. Inver Grove Heights LID Implementation. Available online at http://www.co.washington.mn.us/client_files/documents/phe/ENV/GW-LIDImplement.pdf; accessed on June 25, 2009.
- Midlands Environmental Consultants, Inc. (MECI). 2007. Groundwater Contour Map, MTBE Isopleth Map, and Field Screening Test Results for the Green Avenue BP site, Figures 6, 7, and 9. SCDHEC Site ID 13084. Greenville, SC.
- Natural Resources Conservation Center (NRCS). 2005. Soil Survey Geographic (SSURGO) Database for Greenville, SC. Available online at <http://soils.usda.gov/survey/geography/ssurgo/>, accessed on June 25, 2009.
- South Carolina Department of Health and Environmental Control (DHEC). 2005. South Carolina DHEC Storm Water Management BMP Handbook. Prepared by the DHEC Ocean and Coastal Resource Management. August 2005.
- U.S. Environmental Protection Agency (EPA). 1999. Low-Impact Development Design Strategies – An Integrated Design Approach. Prepared by Prince George’s County, Maryland, Department of Environmental Resources. Largo, MD. June.

ATTACHMENT A

CONCEPTUAL DRAWINGS

GREEN AVENUE SITES, GREENVILLE, SC

Conceptual Design Drawings for Sustainable Redevelopment

Brownfield Sustainability Pilot Project

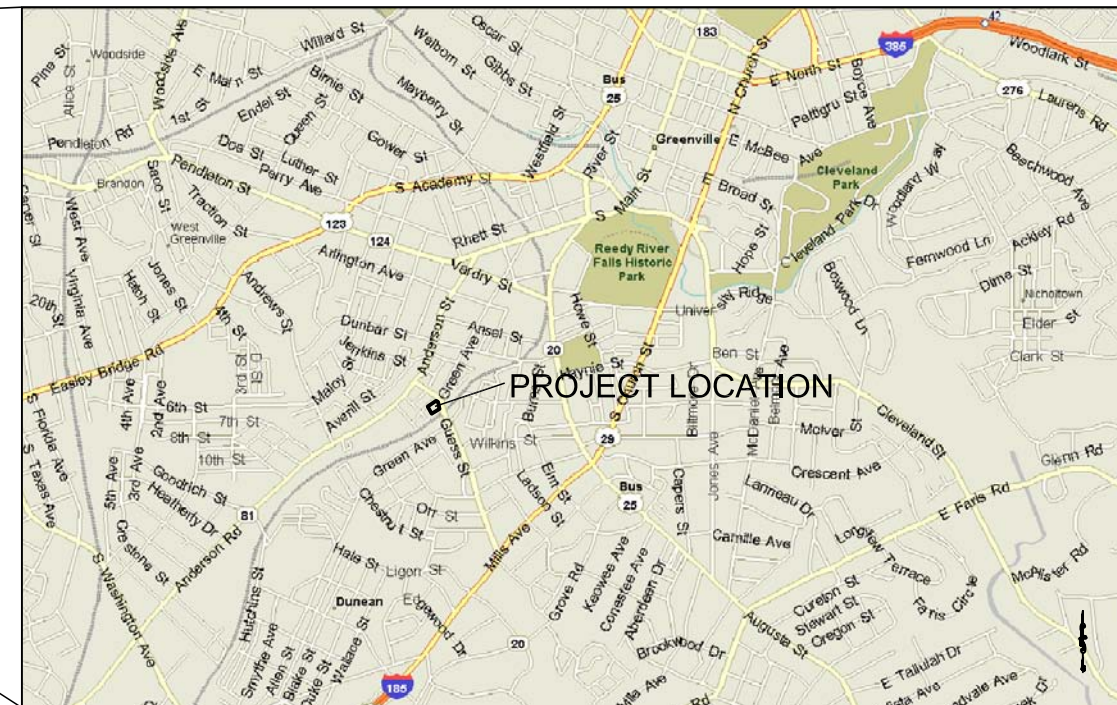
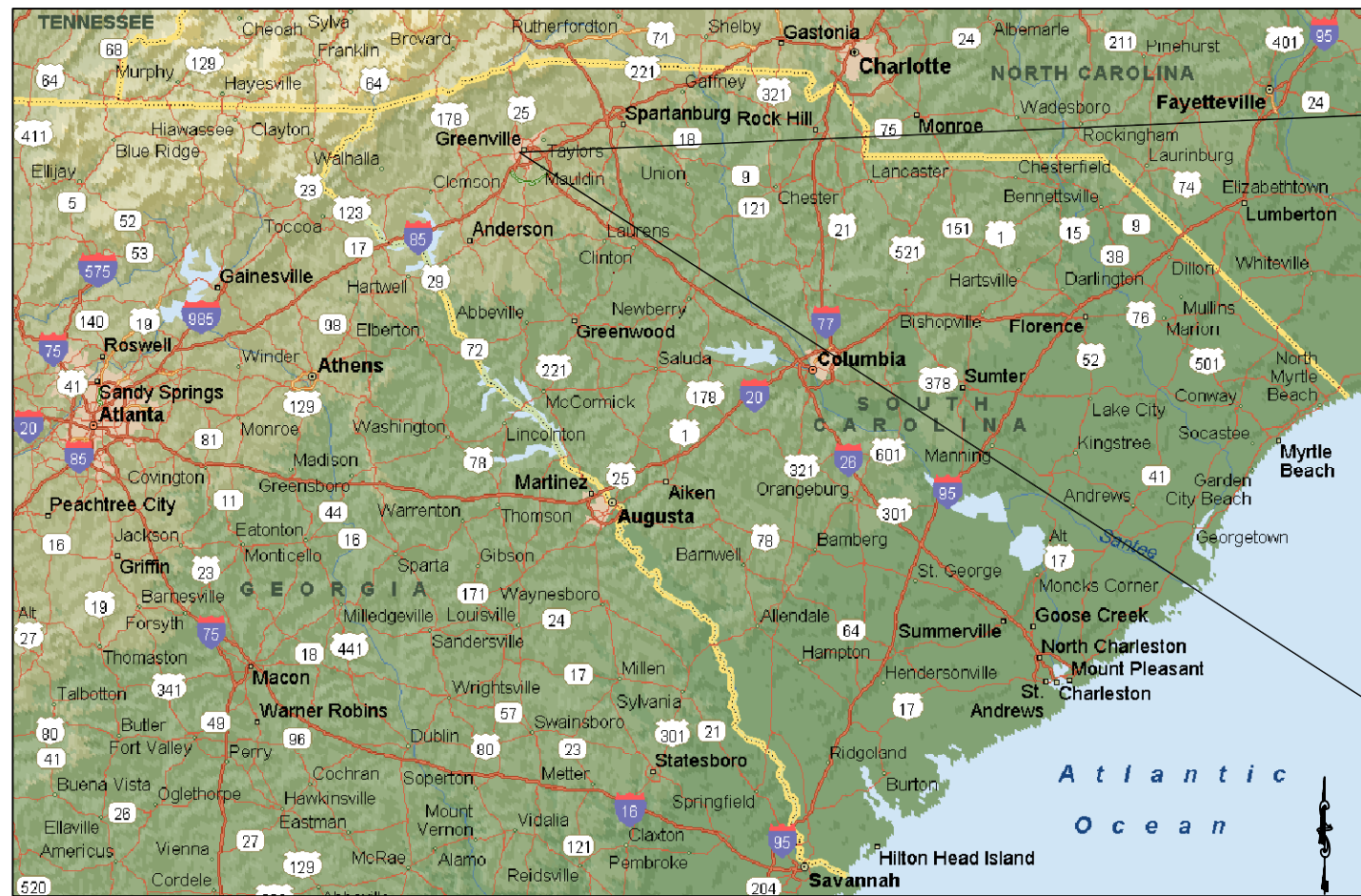

MARK	DATE	DESCRIPTION	BY
			DGS

Client: EPA
Project Location: GREENVILLE, SC.

GREEN AVENUE SITES
EPA BROWNFIELD
SUSTAINABILITY PILOT PROJECT

Project No.: 103DG1392-1802.02
Designed By: TXH
Drawn By: TXH
Checked By:

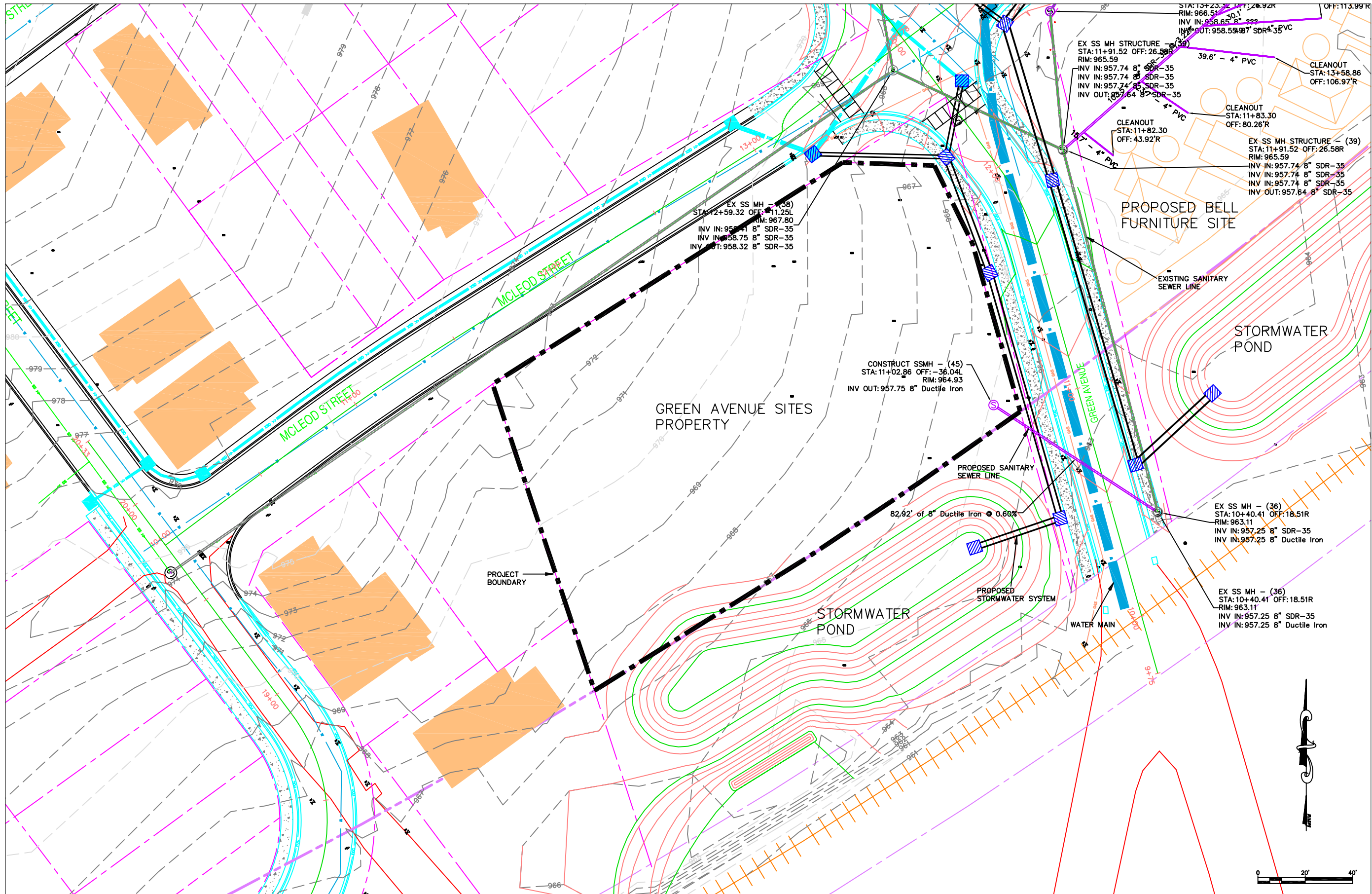

**EXISTING CONDITIONS
AND PROPOSED
CITY INFRASTRUCTURE**

MARK	DATE	DESCRIPTION	BY
			DGS

Client: EPA
 Project Location: GREENVILLE, SC.
**GREEN AVENUE SITES
 EPA BROWNFIELD
 SUSTAINABILITY PILOT PROJECT**

Project No.: 103DG1392-1802.02
 Designed By: TXH
 Drawn By: TXH
 Checked By:

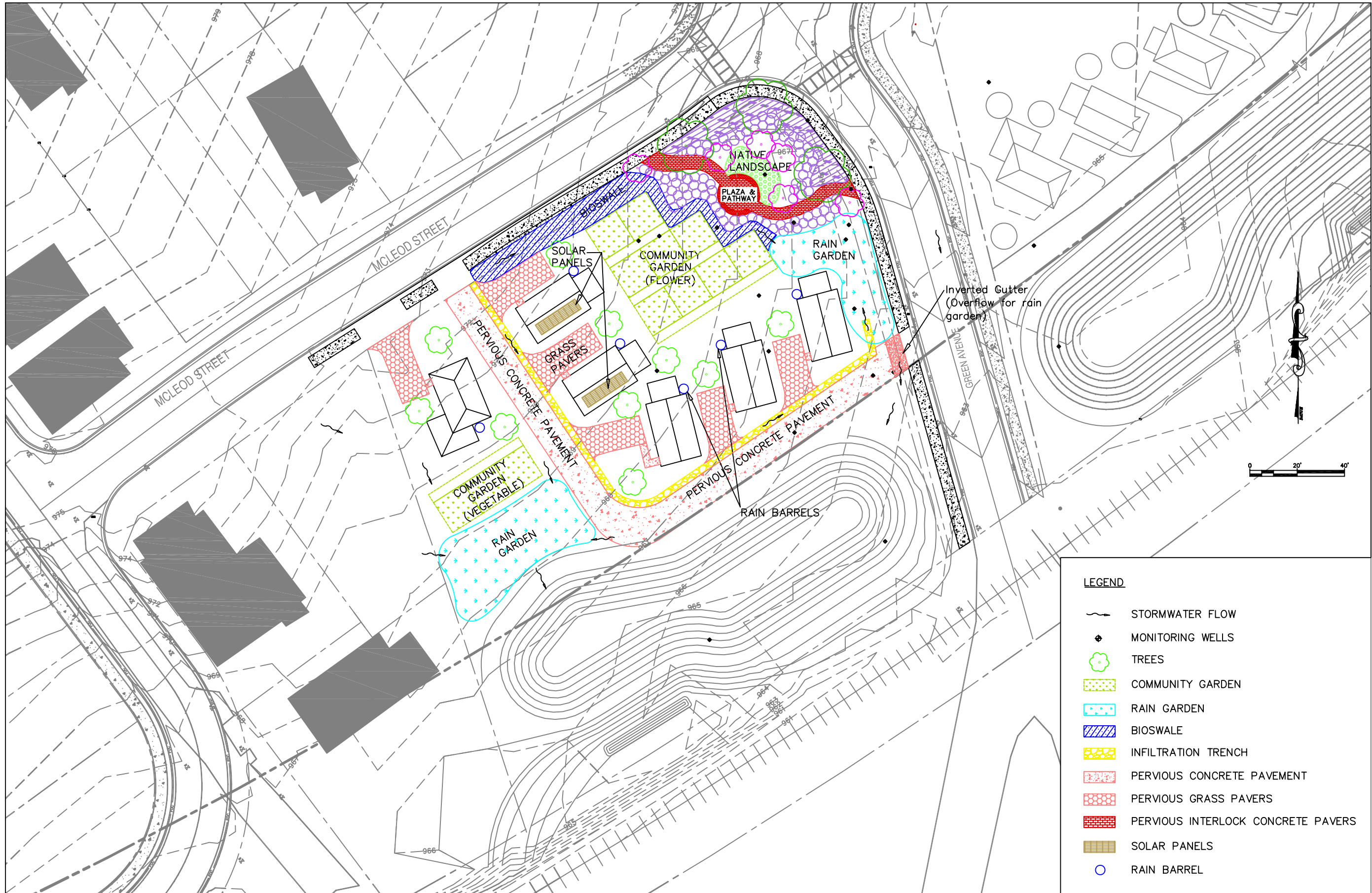

LEGEND

- STORMWATER FLOW
- MONITORING WELLS
- TREES
- COMMUNITY GARDEN
- RAIN GARDEN
- BIOSWALE
- INFILTRATION TRENCH
- PERVIOUS CONCRETE PAVEMENT
- PERVIOUS GRASS PAVERS
- PERVIOUS INTERLOCK CONCRETE PAVERS
- SOLAR PANELS
- RAIN BARREL

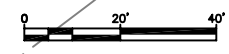

**CONCEPTUAL SITE PLAN
WITH LID PRACTICES**

MARK	DATE	DESCRIPTION
BY	DGS	

Client: EPA
 Project Location: GREENVILLE, SC.
**GREEN AVENUE SITES
 EPA BROWNFIELD
 SUSTAINABILITY PILOT PROJECT**

Project No.: 103DG1392-1802.02
 Designed By: TXH
 Drawn By: TXH
 Checked By:

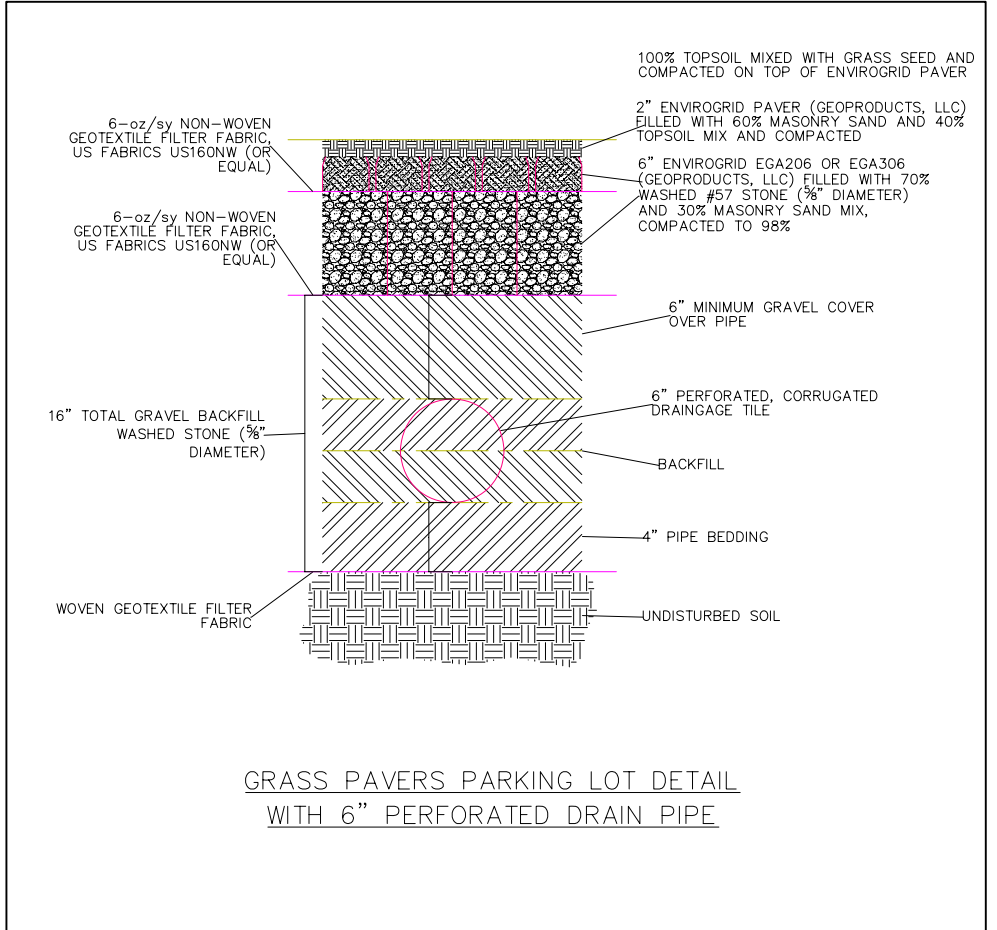

GRASS PAVERS PARKING LOT DETAIL WITH 6" PERFORATED DRAIN PIPE

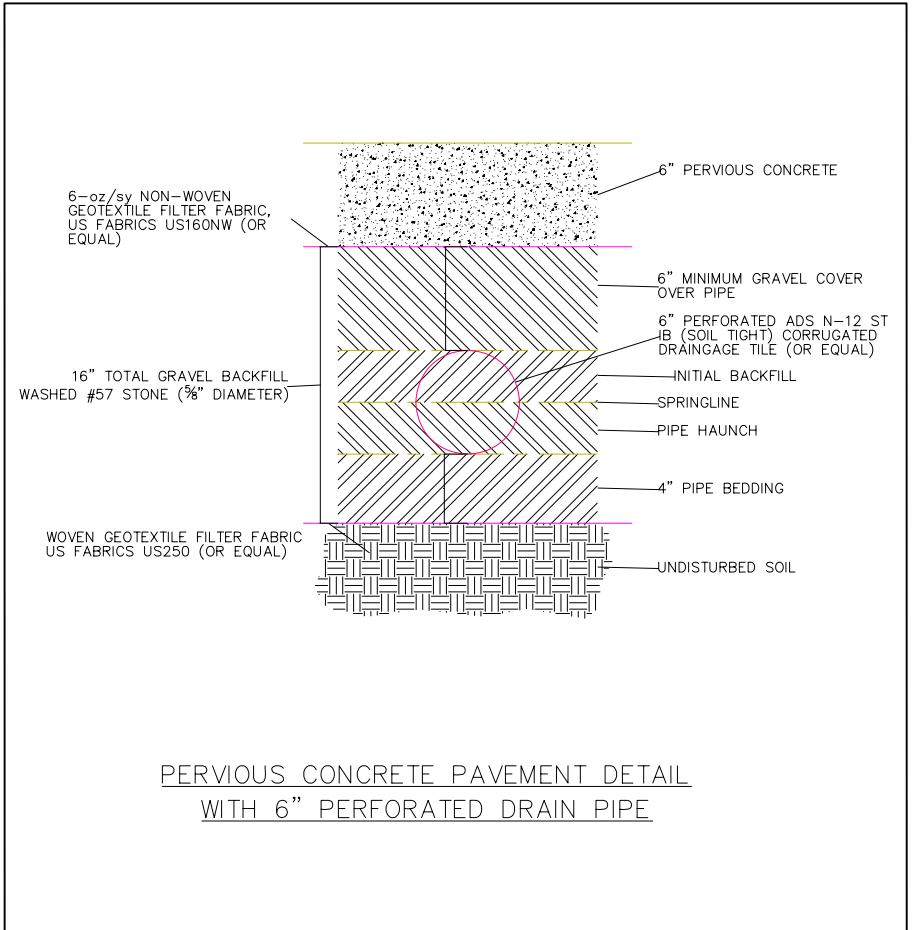

PERVIOUS CONCRETE PAVEMENT DETAIL WITH 6" PERFORATED DRAIN PIPE

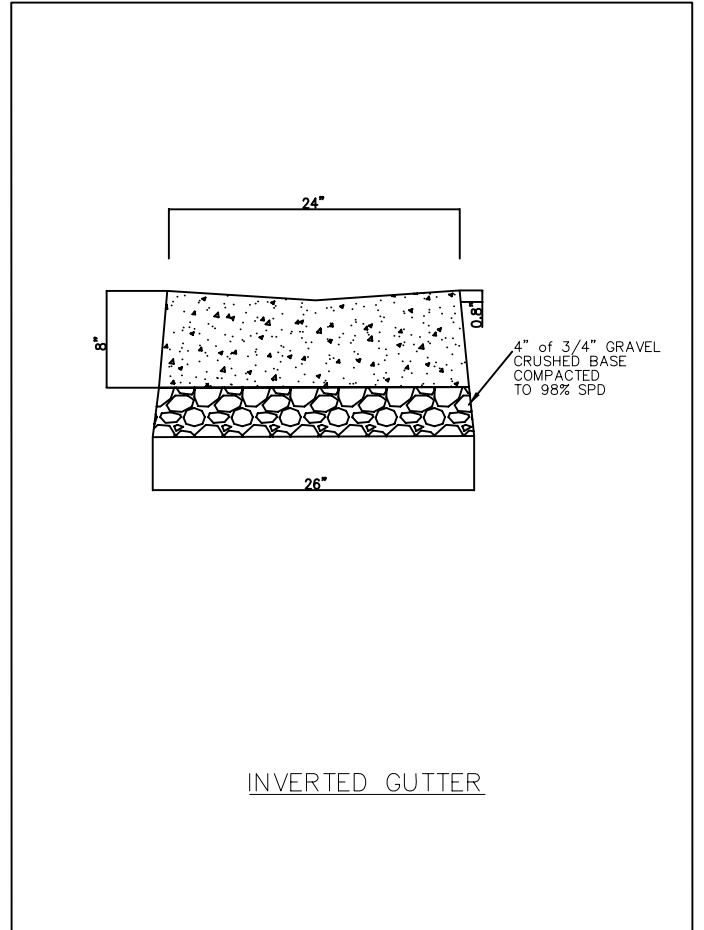

INVERTED GUTTER

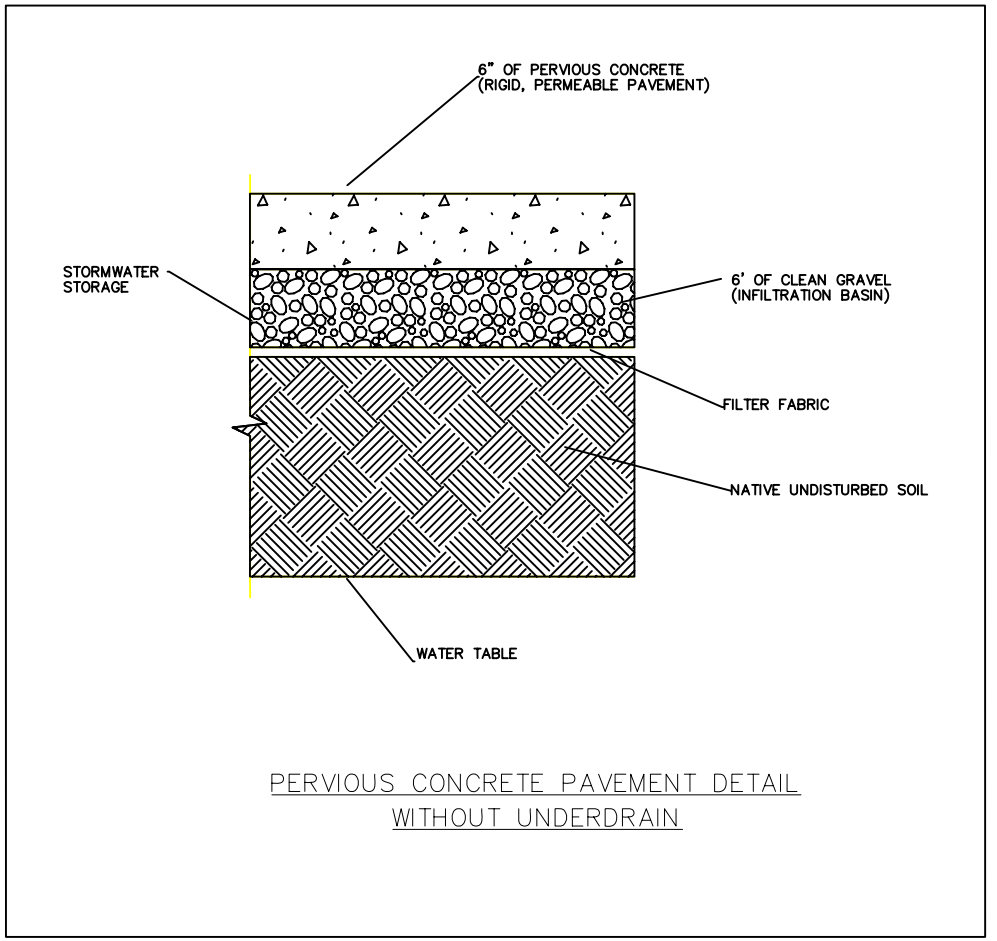

PERVIOUS CONCRETE PAVEMENT DETAIL WITHOUT UNDERDRAIN

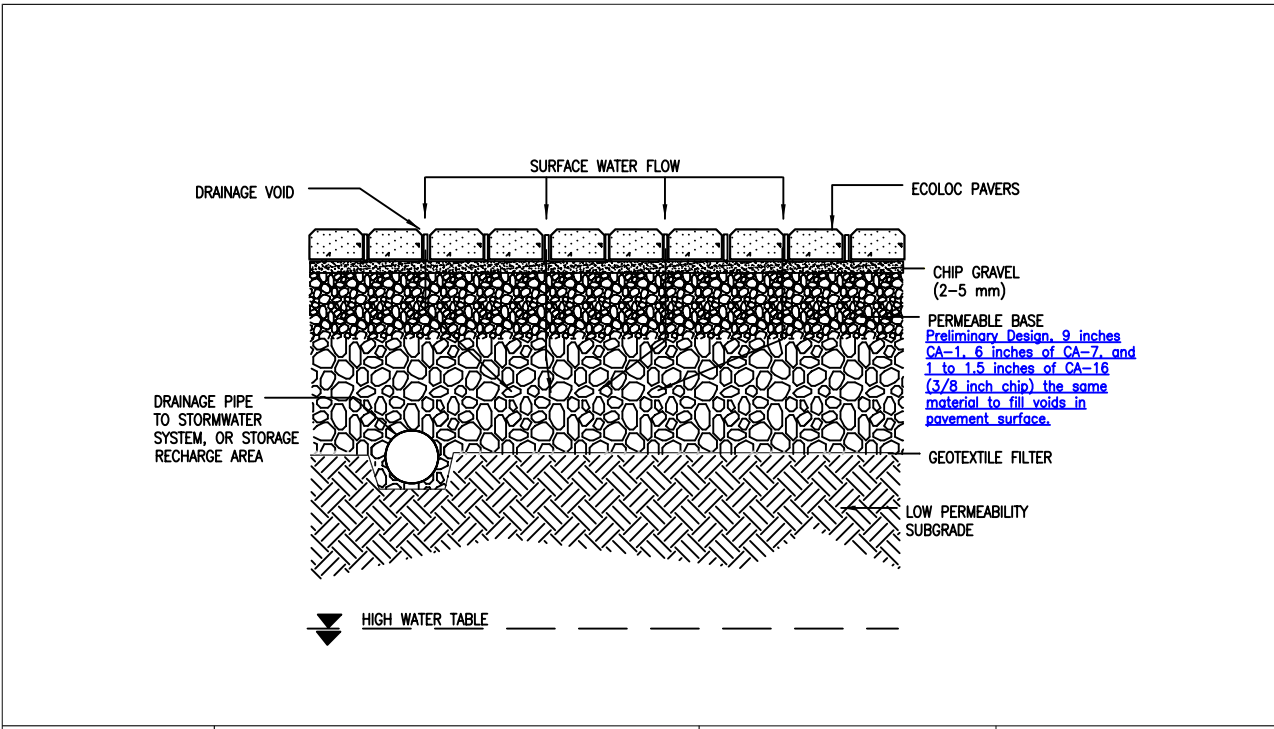

ECOLOC Permeable Pavers Collection and Disposal of Infiltration

UNILOCK®
Designed to be a step ahead

PAVER DETAIL Cross Section

1-800-UNILOCK
www.unilock.com

ECOLOC2.DWG

Engineer's Seal

This cross section is intended for preliminary design purposes only. A qualified professional Engineer should approve the final design and confirm site conditions.

MARK	DATE	DESCRIPTION	BY
			DGS

Client: EPA
Project Location: GREENVILLE, SC.

**GREEN AVENUE SITES
EPA BROWNFIELD
SUSTAINABILITY PILOT PROJECT**

Project No.: 103DG1392-1802.02
Designed By: TXH
Drawn By: TXH
Checked By:

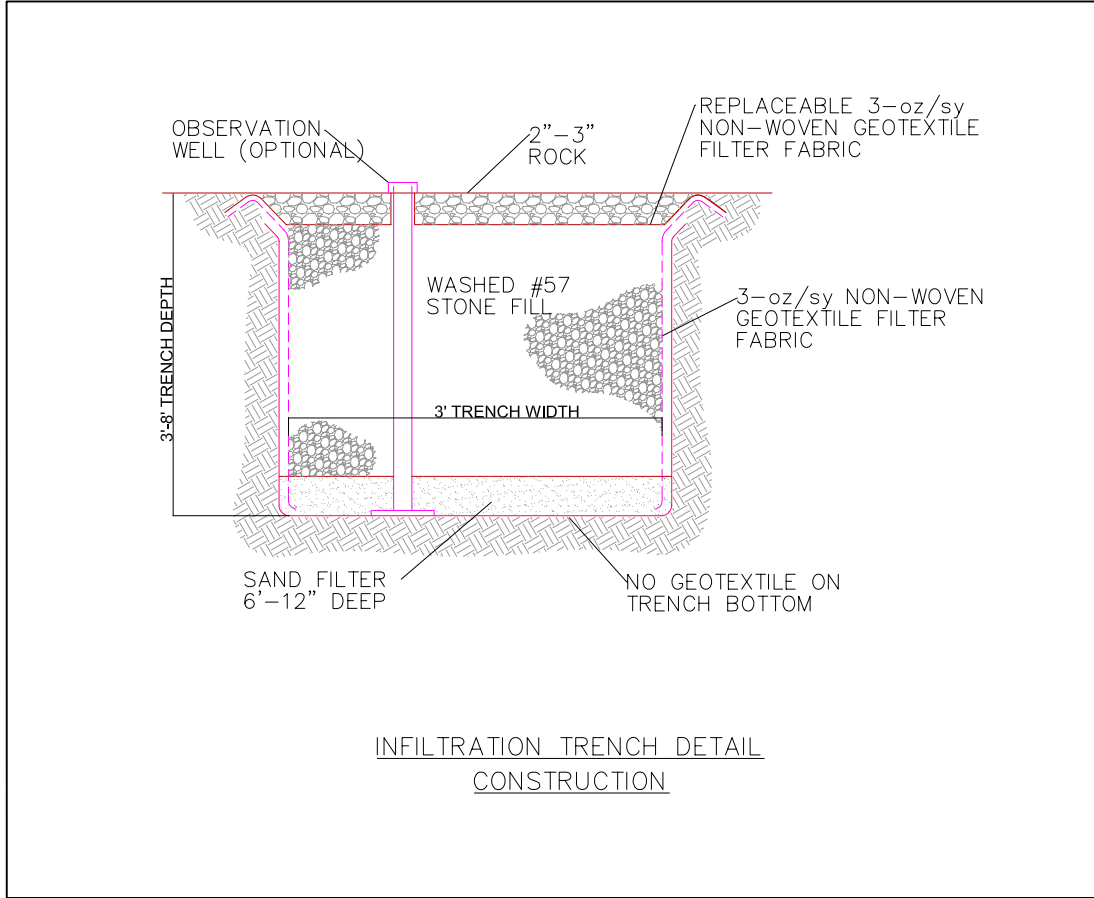

INfiltration TRENCH DETAIL
CONSTRUCTION

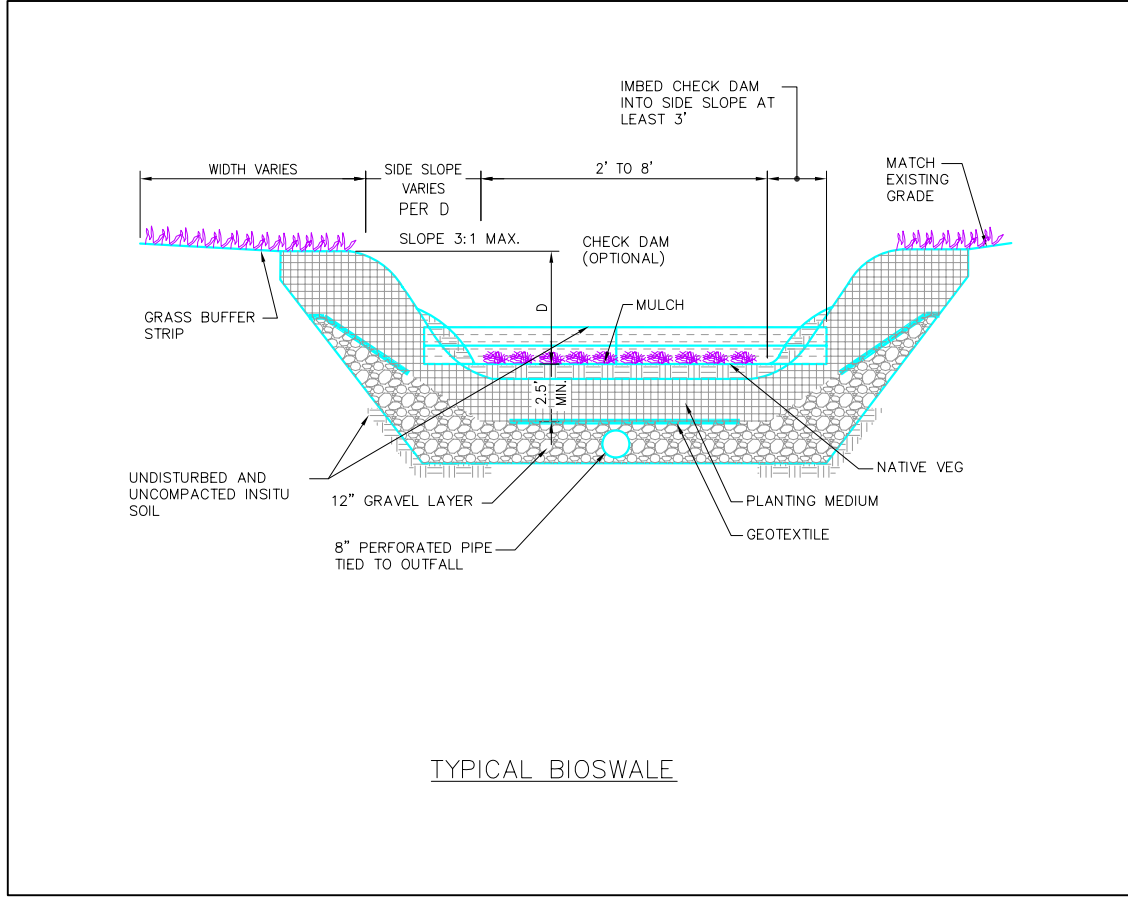

TYPICAL BIOSWALE

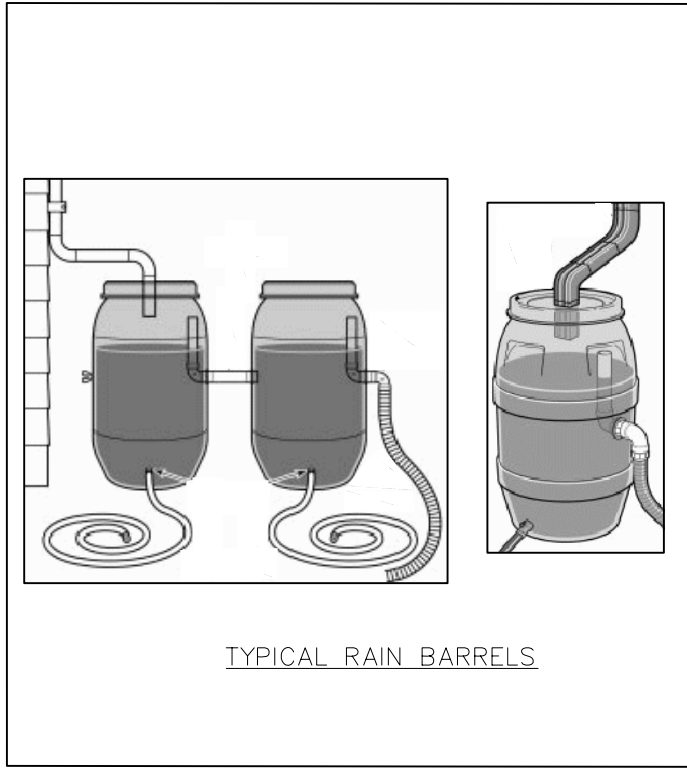

TYPICAL RAIN BARRELS

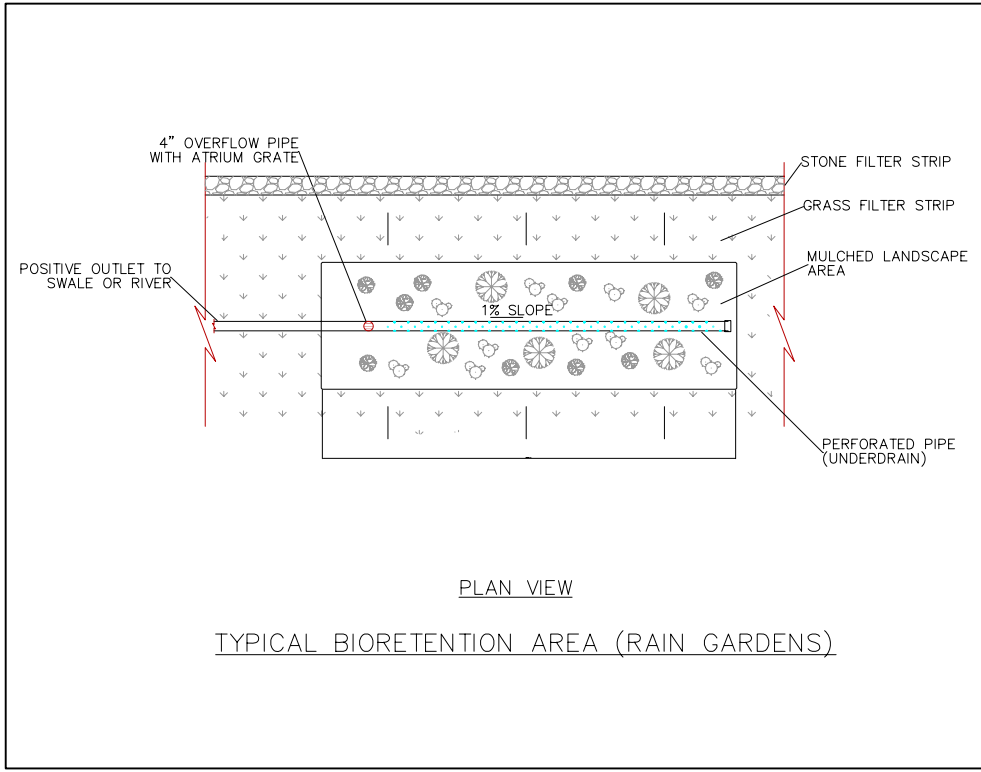

TYPICAL BIORETENTION AREA (RAIN GARDENS)

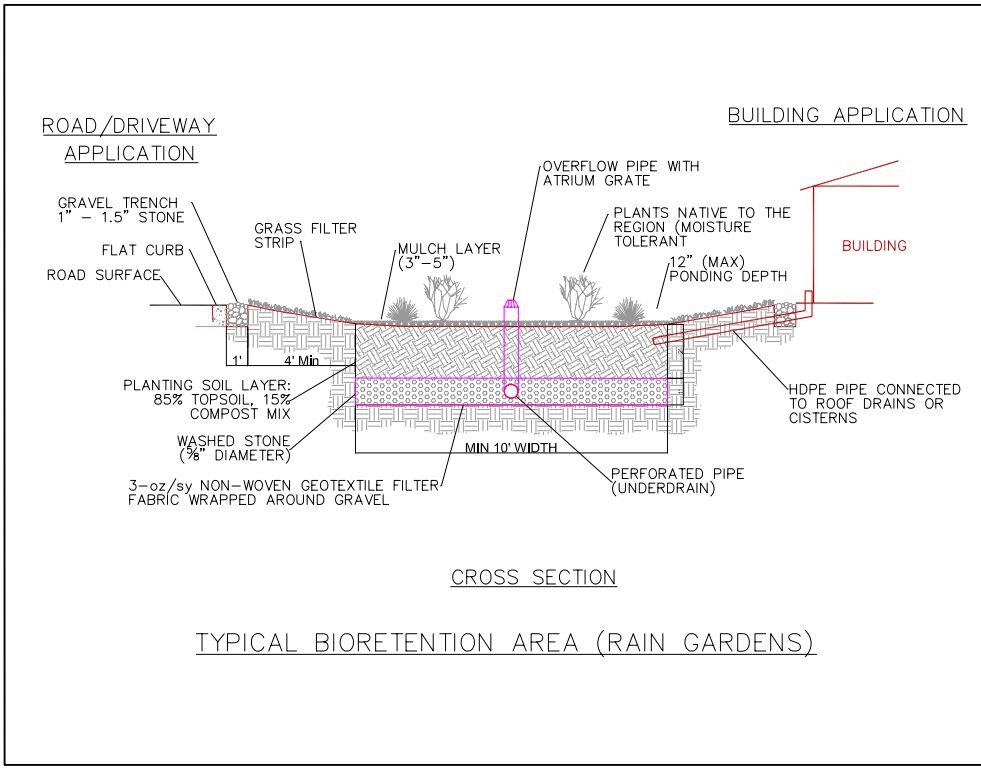

TYPICAL BIORETENTION AREA (RAIN GARDENS)

MARK	DATE	DESCRIPTION	BY
			DGS

ATTACHMENT B

ENVIRONMENTAL INFORMATION FOR THE GREEN AVENUE SITES

Explanation:

- ⊕ Location of Water Table Bracketing Monitoring Well
- ⊕ Location of Double Cased Monitoring Well
- ↑ Estimated Groundwater Flow Direction
- Estimated Location of Existing Underground Storage Tanks

— Ground-Water Elevation Isopleth (feet)

Groundwater Elevation Data			
Well #	Depth to Water (feet)	Well Head Elevation	Groundwater Elevation
MW-1	26.46	99.90	73.44
MW-2	26.20	98.81	72.61
MW-3	32.15	104.89	72.74
MW-4	26.94	99.92	72.98
MW-5	28.67	100.94	72.27
MW-6	27.01	99.52	72.51
MW-7	25.91	97.76	71.85
MW-8	29.64	102.38	72.74
MW-9	29.80	102.97	73.17
MW-10	26.79	100.63	73.84
MW-11	26.46	100.26	73.80
MW-12	26.08	99.07	72.99
MW-13	25.26	98.05	72.79
MW-14	24.50	94.02	69.52
MW-15	33.30	94.59	61.29
MW-16	26.17	98.13	71.96
MW-17D	26.64	99.81	73.17
MW-18D	26.72	98.79	72.07

Notes: Depth to groundwater measured on February 20, 2007.

Contour Interval = 1.00 foot

Double Cased Monitoring Wells MW-17D and MW-18D were not used in contouring.

Ground Water Contours Computer Generated using Surfer by Golden Graphics and Modified by MECI Personnel.

Groundwater Contour Map

Green Avenue BP
Greenville, South Carolina
SCDHEC Site ID 13084

Midlands
Environmental
Consultants, Inc.

JOB NO. 06-1105

DATE March 13, 2007

FIGURE

6

Drawing Based on MECI Field Notes, Tax Maps and a RLS Survey of the Site by Jay S. Joshi dated February 28, 2007.

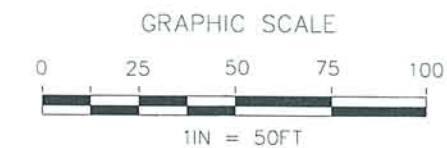

ALL LOCATIONS ARE APPROXIMATE

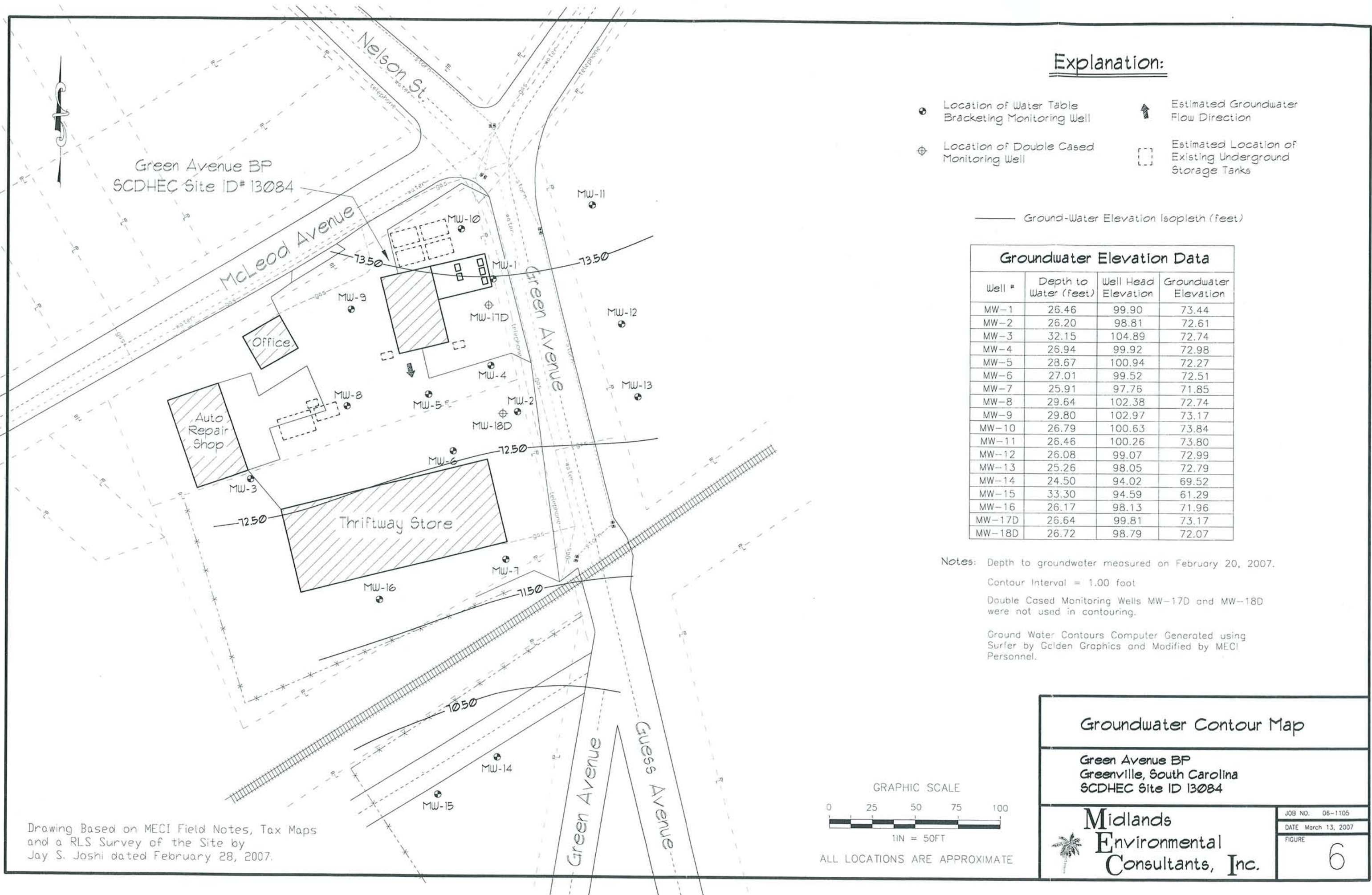

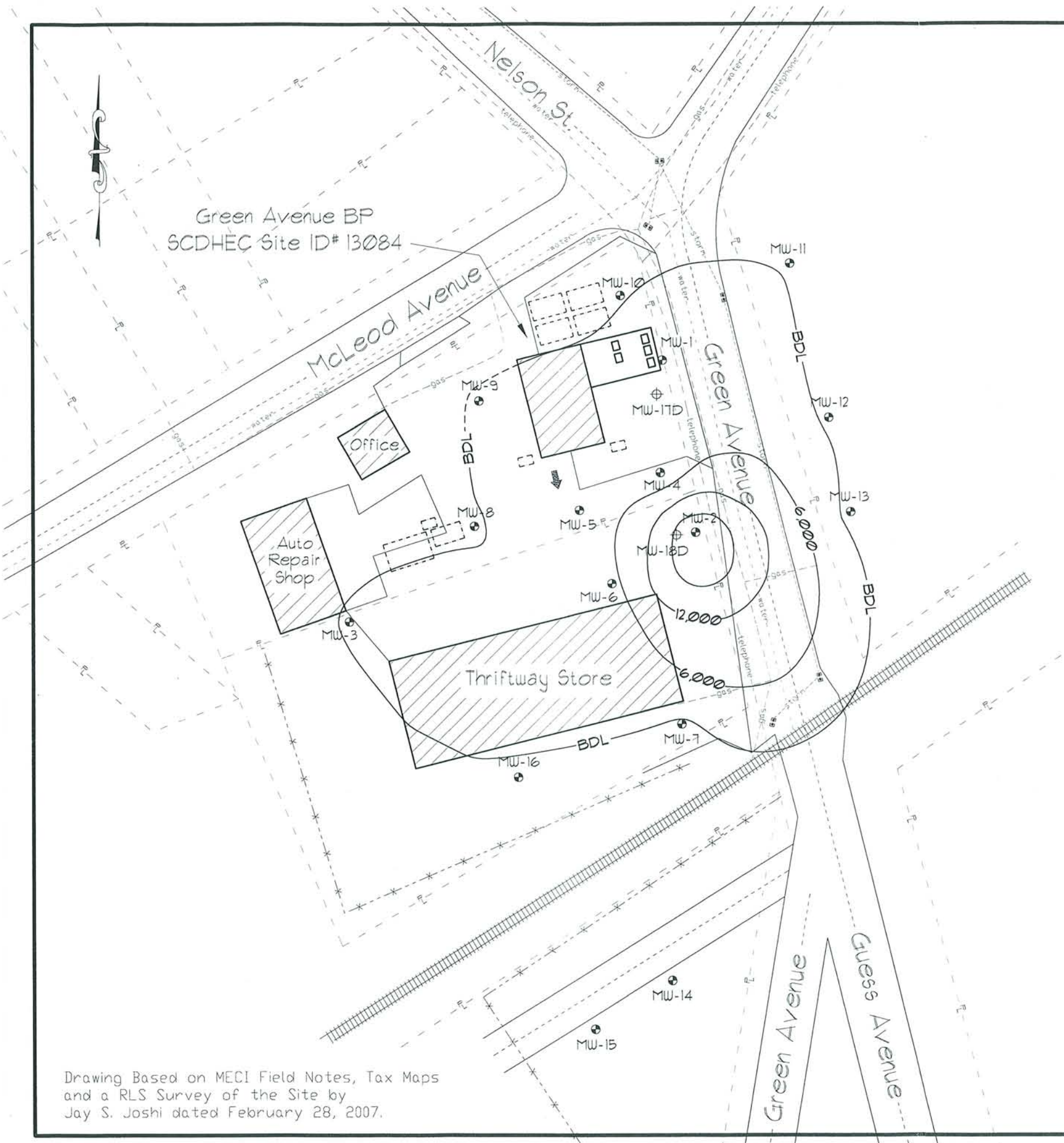

Explanation:

- Location of Water Table Bracketing Monitoring Well
- ⊕ Location of Double Cased Monitoring Well
- ↑ Estimated Groundwater Flow Direction
- Estimated Location of Existing Underground Storage Tanks
- MTBE Concentration Isopleth (ug/l)

COC Concentration Data

Sample #	Benzene (ug/l)	Toluene (ug/l)	Ethylbenzene (ug/l)	Total Xylenes (ug/l)	Total BTEX (ug/l)	MTBE (ug/l)	EDB (ug/l)	Naphthalene (ug/l)
MW-1	34	24	17	48	123	920	BDL	BDL
MW-2	20	BDL	BDL	BDL	20	26,000	BDL	7.4
MW-3	BDL	BDL	BDL	BDL	BDL	18	BDL	BDL
MW-4	30	150	120	570	870	1,900	0.12	6.3
MW-5	11	BDL	BDL	BDL	11	2,300	BDL	5.4
MW-6	BDL	BDL	BDL	BDL	BDL	3,400	BDL	BDL
MW-7	BDL	BDL	BDL	BDL	BDL	BDL	BDL	BDL
MW-8	BDL	BDL	BDL	BDL	BDL	BDL	BDL	BDL
MW-9	BDL	BDL	BDL	BDL	BDL	21	BDL	BDL
MW-10	BDL	BDL	BDL	BDL	BDL	BDL	BDL	BDL
MW-11	BDL	BDL	BDL	BDL	BDL	BDL	BDL	BDL
MW-12	BDL	BDL	BDL	BDL	BDL	BDL	BDL	BDL
MW-13	BDL	BDL	BDL	BDL	BDL	BDL	0.048	BDL
MW-14	BDL	BDL	BDL	BDL	BDL	BDL	BDL	BDL
MW-15	BDL	BDL	BDL	BDL	BDL	BDL	BDL	BDL
MW-16	BDL	BDL	BDL	BDL	BDL	BDL	BDL	BDL
MW-17D	BDL	BDL	BDL	BDL	BDL	BDL	BDL	BDL
MW-18D	BDL	BDL	BDL	BDL	BDL	140	BDL	BDL

Notes: Groundwater samples collected on February 20, 2007.
 Contour Interval = 6,000 ug/l
 Double Cased Wells MW-17D and MW-18D were not used in contouring.
 BDL = Below Detection Limits
 Contours Computer Generated using Surfer by Golden Graphics and Modified by MECI Personnel.

Drawing Based on MECI Field Notes, Tax Maps and a RLS Survey of the Site by Jay S. Joshi dated February 28, 2007.

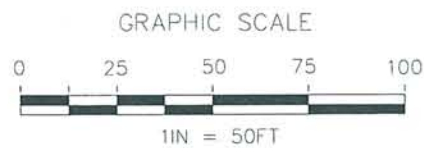

ALL LOCATIONS ARE APPROXIMATE

MTBE Isopleth Map

Green Avenue BP
 Greenville, South Carolina
 SCDHEC Site ID 13084

Midlands Environmental Consultants, Inc.

JOB NO. 06-1105
 DATE March 13, 2007
 FIGURE

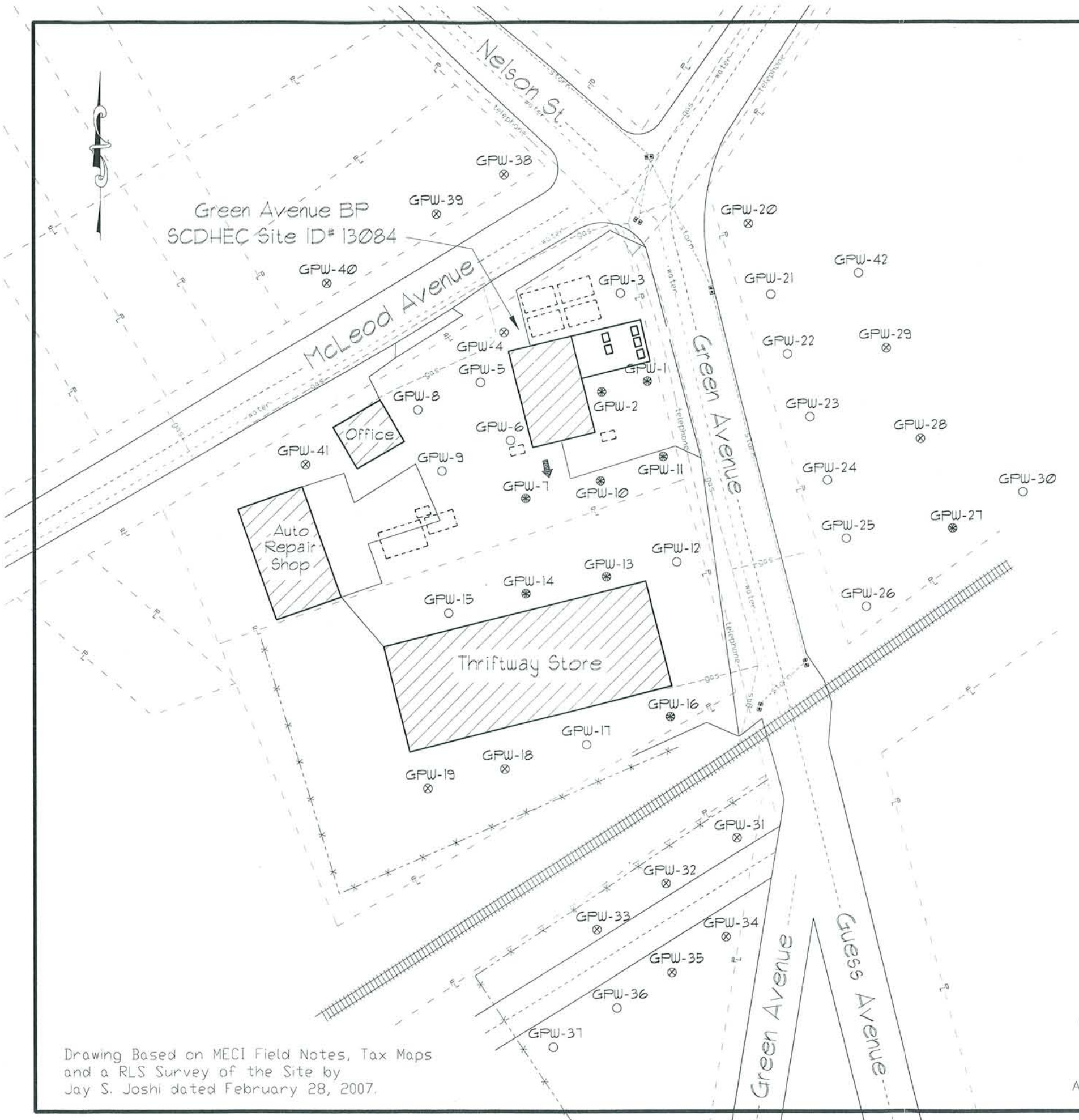

Explanation:

- ⊗ Geoprobe/ImmunoAssay Screening Location Dry Hole
- ⊛ Geoprobe/ImmunoAssay Screening Location BTEX Detected
- Geoprobe/ImmunoAssay Screening Location Not Detected

Sample #	Sample Depth (ft)	Total BTEX (ug/l)	MTBE (ug/l)	Sample #	Sample Depth (ft)	Total BTEX (ug/l)	MTBE (ug/l)
GPW-1	31-35PR	11	13	GPW-22	30-34PR	BDL	13
GPW-2	31-35PR	621	250	GPW-23	27-31PR	BDL	BDL
GPW-3	30-34PR	BDL	BDL	GPW-24	27-31PR	BDL	BDL
GPW-4	28-32PR	DRY	DRY	GPW-25	28-32PR	BDL	BDL
GPW-5	29-33PR	BDL	5	GPW-26	31-35PR	BDL	BDL
GPW-6	31-35PR	34	9.5	GPW-27	30-34PR	10	12
GPW-7	31-35PR	BDL	200	GPW-28	24-28PR	DRY	DRY
GPW-8	31-35PR	BDL	BDL	GPW-29	23-27PR	DRY	DRY
GPW-9	31-35PR	BDL	BDL	GPW-30	29-33PR	BDL	BDL
GPW-10	31-35PR	20.3	1,200	GPW-31	16-20PR	DRY	DRY
GPW-11	31-35PR	BDL	9,700	GPW-32	16-20PR	DRY	DRY
GPW-12	31-35PR	5.5	BDL	GPW-33	18-22PR	DRY	DRY
GPW-13	31-35PR	8.8	550	GPW-34	26-30PR	DRY	DRY
GPW-14	31-35PR	BDL	180	GPW-35	26-30PR	DRY	DRY
GPW-15	31-35PR	BDL	BDL	GPW-36	30-34PR	5.8	BDL
GPW-16	31-35PR	BDL	200	GPW-37	30-34PR	15	BDL
GPW-17	31-35PR	BDL	5.1	GPW-38	16-20PR	DRY	DRY
GPW-18	19-23PR	DRY	DRY	GPW-39	16-20PR	DRY	DRY
GPW-19	19-23PR	DRY	DRY	GPW-40	28-32PR	DRY	DRY
GPW-20	22-26PR	DRY	DRY	GPW-41	31-35PR	DRY	DRY
GPW-21	31-35PR	BDL	BDL	GPW-42	33-37PR	BDL	BDL

Notes: Samples collected on December 13, 14, 15, and 29, 2006.

BDL = Below Detection Limits.

PR = Probe Refused.

Drawing Based on MECI Field Notes, Tax Maps and a RLS Survey of the Site by Jay S. Joshi dated February 28, 2007.

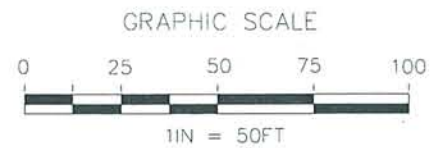

ALL LOCATIONS ARE APPROXIMATE

Field Screening Test Results	
Green Avenue BP Greenville, South Carolina SCDHEC Site ID 13084	
	JOB NO. 06-1105
	DATE March 13, 2007
FIGURE 7	

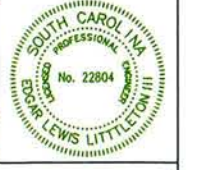
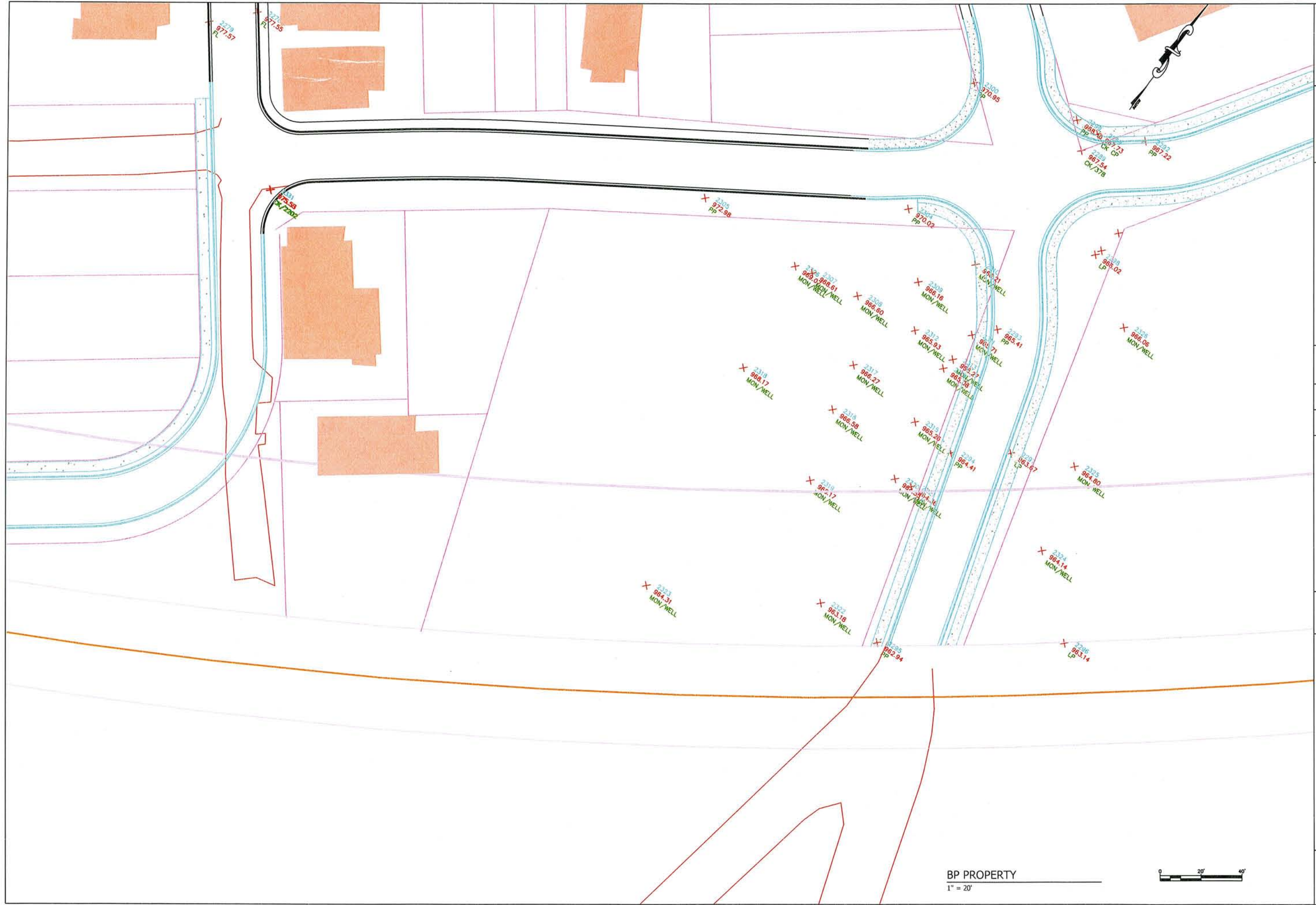

THE CITY OF GREENVILLE
GREENVILLE, S.C.
P.O. BOX 2207

REVISION	No.	DATE	BY/CHKD

PROJECT NO. ED3375	DATE 08/01/2008	DRAWN BY ELL	CHECKED BY RHM
-----------------------	--------------------	-----------------	-------------------

GREEN AVENUE PHASE IIB
GREEN AVENUE
GREENVILLE, S.C.
BP PROPERTY

DRAWING NO.
1

BP PROPERTY
1" = 20'

