

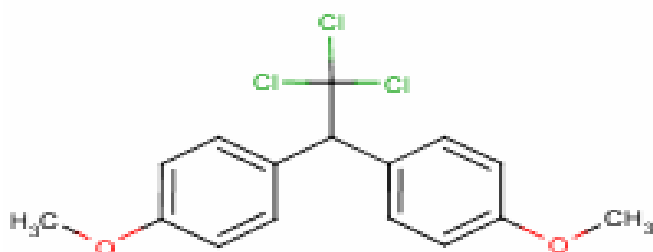

Method 1699: Pesticides in Water, Soil, Sediment, Biosolids, and Tissue by HRGC/HRMS

December 2007

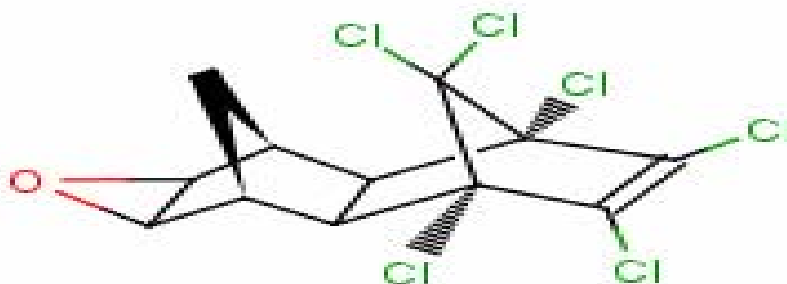

U.S. Environmental Protection Agency
Office of Water
Office of Science and Technology
Engineering and Analysis Division (4303T)
1200 Pennsylvania Avenue, NW
Washington, DC 20460

EPA-821-R-08-001
December 2007

Introduction

EPA Method 1699 determines organochlorine, organophosphorus, triazine, and pyrethroid pesticides in environmental samples by high resolution gas chromatography/high resolution mass spectrometry (HRGC/HRMS) using isotope dilution and internal standard quantitation techniques. This method has been developed for use with aqueous, solid, tissue and biosolids matrices.

Disclaimer

This method has been reviewed by the Engineering and Analytical Support Branch of the Engineering and Analysis Division (EAD) in OST. The method is available for general use, but has not been published in 40 CFR Part 136. Mention of trade names or commercial products does not constitute endorsement or recommendation for use.

Contacts

Questions concerning this method or its application should be addressed to:

Brian Englert, Ph.D.
Environmental Scientist
Engineering & Analytical Support Branch
Engineering and Analysis Division (4303T)
Office of Science and Technology, Office of Water
U.S. Environmental Protection Agency
1200 Pennsylvania Avenue NW
Washington, DC 20460
<http://www.epa.gov/waterscience>
ostcwamethods@epa.gov

Table of Contents

INTRODUCTION.....3

DISCLAIMER3

1.0 SCOPE AND APPLICATION5

2.0 SUMMARY OF METHOD6

3.0 DEFINITIONS AND UNITS OF MEASURE.....7

4.0 INTERFERENCES7

5.0 SAFETY9

6.0 APPARATUS AND MATERIALS12

7.0 REAGENTS AND STANDARDS19

8.0 SAMPLE COLLECTION, PRESERVATION, STORAGE, AND HOLDING TIMES25

9.0 QUALITY ASSURANCE/QUALITY CONTROL26

10.0 CALIBRATION31

11.0 SAMPLE PREPARATION36

12.0 EXTRACTION AND CONCENTRATION.....42

13.0 EXTRACT CLEANUP51

14.0 HRGC/HRMS ANALYSIS57

15.0 SYSTEM AND LABORATORY PERFORMANCE.....58

16.0 QUALITATIVE DETERMINATION61

17.0 QUANTITATIVE DETERMINATION61

18.0 ANALYSIS OF COMPLEX SAMPLES64

19.0 POLLUTION PREVENTION65

20.0 WASTE MANAGEMENT.....65

21.0 METHOD PERFORMANCE66

22.0 REFERENCES.....66

Method 1699: Pesticides in Water, Soil, Sediment, Biosolids, and Tissue by HRGC/HRMS

1.0 Scope and Application

- 1.1 Method 1699 is for determination of selected organochlorine, organo-phosphorus, triazine, and pyrethroid pesticides in multi-media environmental samples by high resolution gas chromatography/high resolution mass spectrometry (HRGC/HRMS).
- 1.2 This Method was developed for use in EPA's Clean Water Act (CWA) programs; other applications are possible. It is based on existing EPA methods (Reference 1) and procedures developed at Axys Analytical Services (Reference 2).
- 1.3 The analytes that may be measured by this method and their corresponding Chemical Abstracts Service Registry Numbers (CASRNs) and ambient water quality criteria are listed in Table 1.
- 1.4 The detection limits and quantitation levels in this Method are usually dependent on the level of interferences rather than instrumental limitations. The method detection limits (MDLs; 40 CFR 136, appendix B) and minimum levels of quantitation (MLs; 68 FR 11790) in Table 1 are the levels at which pesticides can be determined in the absence of interferences.
- 1.5 This Method is restricted for use by analysts experienced in HRGC/HRMS or under the close supervision of such qualified persons. Each laboratory that uses this Method must demonstrate the ability to generate acceptable results using the procedure in Section 9.2.
- 1.6 This method is performance-based which means that you may modify the method to improve performance (e.g., to overcome interferences or improve the accuracy or precision of the results) provided that you meet all performance requirements in this method. These requirements for establishing equivalency of a modification are in Section 9.1.2. For Clean Water Act (CWA) uses, additional flexibility is described at 40 CFR 136.6. Modifications not in the scope of Part 136.6 or in Section 9 of this method may require prior review and approval.

2.0 Summary of Method

Flow charts that summarize procedures for sample preparation, extraction, and analysis are given in Figure 1 for aqueous and solid samples, Figure 2 for multi-phase samples, and Figure 3 for tissue samples.

2.1 Extraction (Section 12)

- 2.1.1 Aqueous samples (samples containing less than one percent solids) – Stable isotopically labeled analogs of the pesticides are spiked into a 1-L sample. The sample is extracted at neutral pH with methylene chloride using separatory funnel extraction (SFE) or continuous liquid/liquid extraction (CLLE).
- 2.1.2 Solid, semi-solid, and multi-phase samples (excluding municipal sludge and tissue) – The labeled compounds are spiked into a sample containing 10 g (dry weight) of solids. Samples containing multiple phases are pressure filtered and any aqueous liquid is discarded. Coarse solids are ground or homogenized. Any non-aqueous liquid from multi-phase samples is combined with the solids and extracted with methylene chloride, methylene chloride:hexane (1:1) or acetone:hexane (1:1) in a Soxhlet extractor or with toluene in a Soxhlet/Dean-Stark (SDS) extractor (Reference 3).
- 2.1.3 Municipal sludges are homogenized, spiked with labeled compounds, and Soxhlet extracted with dichloromethane.
- 2.1.4 Fish and other tissue – A 20-g aliquot of sample is homogenized, and a 10-g aliquot is spiked with the labeled compounds. The sample is mixed with anhydrous sodium sulfate, allowed to dry for 30 minutes minimum, and extracted for 18 - 24 hours using methylene chloride in a Soxhlet extractor. The extract is evaporated to dryness, and the lipid content is determined.

2.2 Concentration (Section 12)

- 2.2.1 Extracts are macro-concentrated using rotary evaporation, a heating mantle, or a Kuderna-Danish evaporator.
- 2.2.2 Extracts to be injected into the HRGC/HRMS are concentrated to a final volume of 20 μ L using nitrogen evaporation (blowdown).

2.3 Cleanup (Section 13)

- 2.3.1 Extracts of aqueous, solid or mixed phase samples are cleaned up using an aminopropyl SPE column followed by a microsilica column.
- 2.3.2 Extracts may be further cleaned up using gel permeation chromatography (GPC) or solid-phase cartridge techniques.

- 2.3.3** Extracts in which the organo-chlorine pesticides only are to be determined may be further cleaned up using silica gel, Florisil, or alumina chromatography.
- 2.4** Determination by GC/HRMS – Immediately prior to injection, a labeled injection internal standard is added to each extract and an aliquot of the extract is injected into the gas chromatograph (GC). The analytes are separated by the GC and detected by a high-resolution ($\geq 8,000$) mass spectrometer. Two exact m/z's for each pesticide are monitored throughout a pre-determined retention time window.
- 2.5** An individual pesticide is identified by comparing the GC retention time and ion-abundance ratio of two exact m/z's with the corresponding retention time of an authentic standard and the theoretical or acquired ion-abundance ratio of the two exact m/z's.
- 2.6** Quantitative analysis is performed in one of two ways using selected ion current profile (SICP) areas:
- 2.6.1** For pesticides for which a labeled analog is available, the GC/HRMS is multi-point calibrated and the concentration is determined using the isotope dilution technique.
- 2.6.2** Pesticides for which a labeled analog is not available are determined using the internal standard technique. The labeled compounds are used as internal standards, affording recovery correction for all pesticides.
- 2.7** The quality of the analysis is assured through reproducible calibration and testing of the extraction, cleanup, and GC/MS systems.

3.0 Definitions and units of measure

Definitions and units of measure are given in the glossary at the end of this Method.

4.0 Interferences

- 4.1** Solvents, reagents, glassware, and other sample processing hardware may yield artifacts, elevated baselines, and/or lock-mass suppression causing misinterpretation of chromatograms. Specific selection of reagents and purification of solvents by distillation in all-glass systems may be required. Where possible, reagents are cleaned by extraction or solvent rinse.
- 4.2** Proper cleaning of glassware is extremely important, because glassware may not only contaminate the samples but may also remove the analytes of interest by adsorption on the glass surface.
- 4.2.1** Glassware should be rinsed with solvent and washed with a detergent solution as soon after use as is practical. Sonication of glassware containing a detergent

solution for approximately 30 seconds may aid in cleaning. Glassware with removable parts, particularly separatory funnels with fluoropolymer stopcocks, must be disassembled prior to detergent washing.

- 4.2.2** After detergent washing, glassware should be rinsed immediately, first with methanol, then with hot tap water. The tap water rinse is followed by another methanol rinse, then acetone, and then methylene chloride.
 - 4.2.3** Baking of glassware in a kiln or other high temperature furnace (300 - 500°C) may be warranted after particularly dirty samples are encountered. The kiln or furnace should be vented to prevent laboratory contamination by pesticide vapors. Baking should be minimized, as repeated baking of glassware may cause active sites on the glass surface that may irreversibly adsorb pesticides. Volumetric ware should not be baked at high temperature.
 - 4.2.4** After drying and cooling, glassware should be sealed and stored in a clean environment to prevent any accumulation of dust or other contaminants. Store inverted or capped with aluminum foil.
 - 4.2.5** Immediately prior to use, the Soxhlet apparatus should be pre-extracted for approximately 3 hours and the extraction apparatus should be rinsed with the extraction solvent.
- 4.3** All materials used in the analysis must be demonstrated to be free from interferences by running reference matrix method blanks (Section 9.5) initially and with each sample batch (samples started through the extraction process on a given 12-hour shift, to a maximum of 20 samples).
- 4.3.1** The reference matrix must simulate, as closely as possible, the sample matrix under test. Ideally, the reference matrix should not contain the pesticides in detectable amounts, but should contain potential interferents in the concentrations expected to be found in the samples to be analyzed.
 - 4.3.2** When a reference matrix that simulates the sample matrix under test is not available, reagent water (Section 7.6.1) can be used to simulate water samples; playground sand (Section 7.6.2) or white quartz sand (Section 7.3.2) can be used to simulate soils; filter paper (Section 7.6.3) can be used to simulate papers and similar materials; and corn oil (Section 7.6.4) can be used to simulate tissues.
- 4.4** Interferences co-extracted from samples will vary considerably from source to source, depending on the diversity of the site being sampled. Interfering compounds may be present at concentrations several orders of magnitude higher than the pesticides. The most frequently encountered interferences are chlorinated biphenyls, chlorinated and brominated dibenzodioxins and dibenzofurans, methoxy biphenyls, hydroxydiphenyl ethers, benzylphenyl ethers, brominated diphenyl ethers, polynuclear aromatics, and polychlorinated naphthalenes. Because very low levels of pesticides are measured by this Method, elimination of interferences is essential. The cleanup steps given in Section 13

can be used to reduce or eliminate these interferences and thereby permit reliable determination of the pesticides at the levels shown in Table 1.

- 4.5** Each piece of reusable glassware should be numbered to associate that glassware with the processing of a particular sample. This will assist the laboratory in tracking possible sources of contamination for individual samples, identifying glassware associated with highly contaminated samples that may require extra cleaning, and determining when glassware should be discarded.
- 4.6** Organic acids and other substances make it difficult to extract and clean up biosolids (sewage sludge) samples. The exact procedures to be used are dependent on the analytes to be determined. If all analytes in this Method are to be determined, gel permeation chromatography (GPC), the amino-propyl SPE column, and the layered alumina/Florisil column have been found effective. For the organo-chlorine pesticides, sequential extraction with acetonitrile and methylene chloride followed by back extraction with sodium sulfate-saturated water has been found effective. An anthropogenic isolation column (Section 13.6; see Section 7.5.2 for column details), GPC (Section 13.2), high performance liquid chromatography (HPLC; Section 13.5), Florisil (Section 13.7), and alumina (Section 13.8) are additional steps that may be employed to minimize interferences in the sludge matrix.
- 4.7** The natural lipid content of tissue can interfere in the analysis of tissue samples for measurement of pesticides. The lipid contents of different species and portions of tissue can vary widely. Lipids are soluble to varying degrees in various organic solvents and may be present in sufficient quantity to overwhelm the column chromatographic cleanup procedures used for sample extracts. Lipids must be removed by the anthropogenic isolation column procedure in Section 13.6, followed by GPC (Section 13.2).

5.0 Safety

- 5.1** The toxicity or carcinogenicity of each chemical used in this Method has not been precisely determined; however, each compound should be treated as a potential health hazard. Exposure to these compounds should be reduced to the lowest possible level.
 - 5.1.1** Some pesticides, most notably 4,4'-DDT and 4,4'-DDD, have been tentatively classified as known or suspected human or mammalian carcinogens. Pure standards of the pesticides should be handled only by highly trained personnel thoroughly familiar with handling and cautionary procedures and the associated risks.
 - 5.1.2** It is recommended that the laboratory purchase dilute standard solutions of the analytes in this Method. However, if primary solutions are prepared, they must be prepared in a hood, and a NIOSH/MESA approved toxic gas respirator must be worn when high concentrations are handled.

- 5.2** This Method does not address all safety issues associated with its use. The laboratory is responsible for maintaining a current awareness file of OSHA regulations regarding the safe handling of the chemicals specified in this Method. A reference file of material safety data sheets (MSDSs) should also be made available to all personnel involved in these analyses. It is also suggested that the laboratory perform personal hygiene monitoring of each analyst who uses this Method and that the results of this monitoring be made available to the analyst. Additional information on laboratory safety can be found in References 4-7. The references and bibliography at the end of Reference 6 are particularly comprehensive in dealing with the general subject of laboratory safety.
- 5.3** The pure pesticides and samples suspected to contain high concentrations of these compounds are handled using essentially the same techniques employed in handling radioactive or infectious materials. Well-ventilated, controlled access laboratories are required. Assistance in evaluating the health hazards of particular laboratory conditions may be obtained from certain consulting laboratories and from State Departments of Health or Labor, many of which have an industrial health service. Each laboratory must develop a strict safety program for handling these compounds. The practices in Reference 8 for handling chlorinated dibenzo-*p*-dioxins and dibenzofurans (CDDs/CDFs) are also recommended for handling pesticides.
- 5.3.1** Facility – When finely divided samples (dusts, soils, dry chemicals) are handled, all operations (including removal of samples from sample containers, weighing, transferring, and mixing) should be performed in a glove box demonstrated to be leak tight or in a fume hood demonstrated to have adequate air flow. Gross losses to the laboratory ventilation system must not be allowed. Handling of the dilute solutions normally used in analytical and animal work presents no inhalation hazards except in the case of an accident.
- 5.3.2** Protective equipment – Disposable plastic gloves, apron or lab coat, safety glasses or mask, and a glove box or fume hood adequate for radioactive work should be used. During analytical operations that may give rise to aerosols or dusts, personnel should wear respirators equipped with activated carbon filters. Eye protection (preferably full face shields) must be worn while working with exposed samples or pure analytical standards. Latex gloves are commonly used to reduce exposure of the hands. When handling samples suspected or known to contain high concentrations of the pesticides, an additional set of gloves can also be worn beneath the latex gloves.
- 5.3.3** Training – Workers must be trained in the proper method of removing contaminated gloves and clothing without contacting the exterior surfaces.
- 5.3.4** Personal hygiene – Hands and forearms should be washed thoroughly after each operation involving high concentrations of the pesticides, and before breaks (coffee, lunch, and shift).

- 5.3.5** Confinement – Isolated work areas posted with signs, segregated glassware and tools, and plastic absorbent paper on bench tops will aid in confining contamination.
- 5.3.6** Effluent vapors – The effluent of the sample splitter from the gas chromatograph (GC) and from roughing pumps on the mass spectrometer (MS) should pass through either a column of activated charcoal or be bubbled through a trap containing oil or high-boiling alcohols to condense pesticide vapors.
- 5.3.7** Waste handling – Good technique includes minimizing contaminated waste. Plastic bag liners should be used in waste cans. Janitors and other personnel should be trained in the safe handling of waste.
- 5.3.8** Decontamination
- 5.3.8.1** Decontamination of personnel – Use any mild soap with plenty of scrubbing action.
- 5.3.8.2** Glassware, tools, and surfaces – Chlorothene NU Solvent is a less toxic solvent that should be effective in removing pesticides. Satisfactory cleaning may be accomplished by rinsing with Chlorothene, then washing with any detergent and water. If glassware is first rinsed with solvent, the wash water may be disposed of in the sewer. Given the cost of disposal, it is prudent to minimize solvent wastes.
- 5.3.9** Laundry – Clothing known to be contaminated should be collected in plastic bags. Persons that convey the bags and launder clothing should be advised of the hazard and trained in proper handling. Clothing may be put into a washer without contact if the launderer knows of the potential problem. The washer should be run through a cycle before being used again for other clothing.
- 5.3.10** Wipe tests – A useful method of determining cleanliness of work surfaces and tools is to perform a wipe test of the surface suspected of being contaminated.
- 5.3.10.1** Using a piece of filter paper moistened with Chlorothene or other solvent, wipe an area approximately 10 x 10 cm.
- 5.3.10.2** Extract and analyze the wipe by GC with an electron capture detector (ECD) or by this Method.
- 5.3.10.3** Using the area wiped (e.g., 10 x 10 cm = 0.01 m²), calculate the concentration in µg/m². A concentration less than 1 µg/m² indicates acceptable cleanliness; anything higher warrants further cleaning. More than 100 µg/m² constitutes an acute hazard and requires prompt cleaning before further use of the equipment or work space, and indicates that unacceptable work practices have been employed.

- 5.4** Biosolids samples may contain high concentrations of biohazards, and must be handled with gloves and opened in a hood or biological safety cabinet to prevent exposure. Laboratory staff should know and observe the safety procedures required in a microbiology laboratory that handles pathogenic organisms when handling biosolids samples.

6.0 Apparatus and materials

Note: Brand names, suppliers, and part numbers are for illustration purposes only and no endorsement is implied. Equivalent performance may be achieved using apparatus and materials other than those specified here. Meeting the performance requirements of this Method is the responsibility of the laboratory.

6.1 Sampling equipment for discrete or composite sampling

6.1.1 Sample bottles and caps

6.1.1.1 Liquid samples (waters, sludges and similar materials containing 5 percent solids or less) – Sample bottle, amber glass, 1.1-L minimum, with screw cap.

6.1.1.2 Solid samples (soils, sediments, sludges, paper pulps, filter cake, compost, and similar materials that contain more than 5 percent solids) – Sample bottle, wide mouth, amber glass, 500-mL minimum.

6.1.1.3 If amber bottles are not available, samples must be protected from light.

6.1.1.4 Bottle caps – Threaded to fit sample bottles. Caps must be lined with fluoropolymer.

6.1.1.5 Cleaning

6.1.1.5.1 Bottles are detergent water washed, then solvent rinsed before use.

6.1.1.5.2 Liners are detergent water washed and rinsed with reagent water (Section 7.6.1).

6.1.2 Compositing equipment – Automatic or manual compositing system incorporating glass containers cleaned per bottle cleaning procedure above. Only glass or fluoropolymer tubing must be used. If the sampler uses a peristaltic pump, a minimum length of compressible silicone rubber tubing may be used in the pump only. Before use, the tubing must be thoroughly rinsed with methanol, followed by repeated rinsing with reagent water to minimize sample contamination. An integrating flow meter is used to collect proportional composite samples.

6.2 Equipment for glassware cleaning

Note: *If blanks from bottles or other glassware or with fewer cleaning steps than required in this Method show no detectable pesticide contamination, unnecessary cleaning steps and equipment may be eliminated.*

6.2.1 Laboratory sink with overhead fume hood

6.2.2 Kiln – Capable of reaching 450°C within 2 hours and maintaining 450 - 500°C within $\nabla 10^{\circ}\text{C}$, with temperature controller and safety switch (Cress Manufacturing Co, Santa Fe Springs, CA, B31H, X31TS, or equivalent). See the precautions in Section 4.2.3.

6.2.3 Aluminum foil – solvent rinsed or baked in a kiln. If baked in a kiln, heavy-duty aluminum foil is required, as thinner foil will become brittle and unusable.

6.3 Equipment for sample preparation

6.3.1 Laboratory fume hood of sufficient size to contain the sample preparation equipment listed below.

6.3.2 Glove box (optional)

6.3.3 Tissue homogenizer – VirTis Model 45 Macro homogenizer (American Scientific Products H-3515, or equivalent) with stainless steel Macro-shaft and Turbo-shear blade.

6.3.4 Meat grinder – Hobart, or equivalent, with 3- to 5-mm holes in inner plate.

6.3.5 Equipment for determining percent moisture

6.3.5.1 Oven – Capable of maintaining a temperature of $110 \nabla 5^{\circ}\text{C}$

6.3.5.2 Desiccator

6.3.6 Balances

6.3.6.1 Analytical – Capable of weighing 0.1 mg

6.3.6.2 Top loading – Capable of weighing 10 mg

6.4 Extraction apparatus

6.4.1 Water and solid samples

- 6.4.1.1** pH meter, with combination glass electrode
- 6.4.1.2** pH paper, wide range (Hydrion Papers, or equivalent)
- 6.4.1.3** Graduated cylinder, glass, 1-L capacity and Erlenmeyer Flask, glass, 1-L capacity
- 6.4.1.4** Liquid/liquid extraction – Separatory funnels, 250-, 500-, and 2000-mL, with fluoropolymer stopcocks
- 6.4.1.5** Solid-phase extraction
 - 6.4.1.5.1** 1-L filtration apparatus, including glass funnel, frit support, clamp, adapter, stopper, filtration flask, and vacuum tubing (Figure 4). For wastewater samples, the apparatus should accept 90 or 144 mm disks. For drinking water or other samples containing low solids, smaller disks may be used.
 - 6.4.1.5.2** Vacuum source – Capable of maintaining 25 in. Hg, equipped with shutoff valve and vacuum gauge
 - 6.4.1.5.3** Glass-fiber filter – Whatman GMF 150 (or equivalent), 1 micron pore size, to fit filtration apparatus in Section 6.4.1.5.1
 - 6.4.1.5.4** Solid-phase extraction disk containing octadecyl (C₁₈) bonded silica uniformly enmeshed in an inert matrix – Fisher Scientific 14-378F (or equivalent), to fit filtration apparatus in Section 6.4.1.5.1
- 6.4.1.6** Continuous liquid/liquid extraction (CLLE) – Fluoropolymer or glass connecting joints and stopcocks without lubrication, 1.5-2 L capacity (Hershberg-Wolf Extractor, Cal-Glass, Costa Mesa, California, 1000 mL or 2000 mL, or equivalent)
- 6.4.2** Soxhlet/Dean-Stark (SDS) extractor (Figure 5 and Reference 3) for filters and solid/sludge samples
 - 6.4.2.1** Soxhlet – 50-mm ID, 200-mL capacity with 500-mL flask (Cal-Glass LG-6900, or equivalent, except substitute 500-mL round-bottom flask for 300-mL flat-bottom flask)
 - 6.4.2.2** Thimble – 43 H 123 to fit Soxhlet (Cal-Glass LG-6901-122, or equivalent)
 - 6.4.2.3** Moisture trap – Dean Stark or Barret with fluoropolymer stopcock, to fit Soxhlet

6.4.2.4 Heating mantle – Hemispherical, to fit 500-mL round-bottom flask (Cal-Glass LG-8801-112, or equivalent)

6.4.2.5 Variable transformer – Powerstat (or equivalent), 110-volt, 10-amp

6.4.3 Beakers – 400- to 500-mL

6.4.4 Spatulas – Stainless steel

6.5 Filtration apparatus

6.5.1 Pyrex glass wool – Solvent-extracted using a Soxhlet or SDS extractor for 3 hours minimum

6.5.2 Glass funnel – 125- to 250-mL

6.5.3 Glass-fiber filter paper – Whatman GF/D (or equivalent), to fit glass funnel in Section 6.5.2.

6.5.4 Drying column – 15- to 20-mm ID Pyrex chromatographic column equipped with coarse-glass frit or glass-wool plug

6.5.5 Buchner funnel – 15-cm

6.5.6 Glass-fiber filter paper for Buchner funnel above

6.5.7 Filtration flasks – glass, 1.5- to 2.0-L, with side arm

6.5.8 Pressure filtration apparatus – Millipore YT30 142 HW, or equivalent

6.6 Centrifuge apparatus

6.6.1 Centrifuge – Capable of rotating 500-mL centrifuge bottles or 15-mL centrifuge tubes at 5,000 rpm minimum

6.6.2 Centrifuge bottles – 500-mL, with screw-caps, to fit centrifuge

6.6.3 Centrifuge tubes – 12- to 15-mL, with screw-caps, to fit centrifuge

6.7 Cleanup apparatus

6.7.1 Automated gel permeation chromatograph (Analytical Biochemical Labs, Inc, Columbia, MO, Model GPC Autoprep 1002, or equivalent)

- 6.7.1.1** Column – 600-700 mm long H 25 mm ID glass, packed with 70 g of 200-400 mesh SX-3 Bio-beads (Bio-Rad Laboratories, Richmond, CA, or equivalent)
- 6.7.1.2** Syringe – 10-mL, with Luer fitting
- 6.7.1.3** Syringe filter holder – stainless steel, and glass-fiber or fluoropolymer filters (Gelman 4310, or equivalent)
- 6.7.1.4** UV detectors – 254-nm, preparative or semi-preparative flow cell (Isco, Inc., Type 6; Schmadzu, 5-mm path length; Beckman-Altex 152W, 8- μ L micro-prep flow cell, 2-mm path; Pharmacia UV-1, 3-mm flow cell; LDC Milton-Roy UV-3, monitor #1203; or equivalent)
- 6.7.2** Reverse-phase high-performance liquid chromatograph (Reference 9)
 - 6.7.2.1** Pump – Perkin-Elmer Series 410, or equivalent
 - 6.7.2.2** Injector – Perkin-Elmer ISS-100 Autosampler, or equivalent
 - 6.7.2.3** 6-Port switching valve – Valco N60, or equivalent
 - 6.7.2.4** Column – Hypercarb, 100 x 4.6 mm, 5 Φ m particle size, Keystone Scientific, or equivalent
 - 6.7.2.5** Detector – Altex 110A (or equivalent) operated at 0.02 AUFS at 235 nm
 - 6.7.2.6** Fraction collector – Isco Foxy II, or equivalent
- 6.7.3** Pipets, precleaned
 - 6.7.3.1** Disposable, Pasteur, 150-mm long x 5-mm ID (Fisher Scientific 13-678-6A, or equivalent)
 - 6.7.3.2** Disposable, serological, 50-mL (8- to 10- mm ID)
- 6.7.4** Glass chromatographic columns
 - 6.7.4.1** 150-mm long x 8-mm ID, (Kontes K-420155, or equivalent) with coarse-glass frit or glass-wool plug and 250-mL reservoir
 - 6.7.4.2** 200-mm long x 15-mm ID, with coarse-glass frit or glass-wool plug and 250-mL reservoir
 - 6.7.4.3** 300-mm long x 22-mm ID, with coarse-glass frit, 300-mL reservoir, and glass or fluoropolymer stopcock

- 6.7.5** Oven – For baking and storage of adsorbents, capable of maintaining a constant temperature (∇ 5°C) in the range of 105-250°C
- 6.7.6** System for solid-phase extraction
 - 6.7.6.1** Vac-Elute Manifold (Analytichem International, or equivalent)
 - 6.7.6.2** Vacuum trap: Made from 500-mL sidearm flask fitted with single-hole rubber stopper and glass tubing
 - 6.7.6.3** Rack for holding 50-mL volumetric flasks in the manifold
- 6.8** Concentration apparatus
 - 6.8.1** Rotary evaporator – Buchi/Brinkman-American Scientific No. E5045-10 or equivalent, equipped with a variable temperature water bath
 - 6.8.1.1** Vacuum source for rotary evaporator equipped with vacuum gauge and with shutoff valve at the evaporator
 - 6.8.1.2** A recirculating water pump and chiller are recommended. Use of tap water for cooling the evaporator wastes large volumes of water and can lead to inconsistent performance as water temperatures and pressures vary.
 - 6.8.1.3** Round-bottom flask – 100-mL and 500-mL or larger, with ground-glass fitting compatible with the rotary evaporator
 - 6.8.2** Kuderna-Danish (K-D) concentrator
 - 6.8.2.1** Concentrator tube – 10-mL, graduated (Kontes K-570050-1025, or equivalent) with calibration verified. Ground-glass stopper (size 19/22 joint) is used to prevent evaporation of extracts.
 - 6.8.2.2** Evaporation flask – 500-mL (Kontes K-570001-0500, or equivalent), attached to concentrator tube with springs (Kontes K-662750-0012 or equivalent)
 - 6.8.2.3** Snyder column – Three-ball macro (Kontes K-503000-0232, or equivalent)

- 6.8.2.4** Boiling chips
 - 6.8.2.4.1** Glass or silicon carbide – Approximately 10/40 mesh, extracted with methylene chloride and baked at 450°C for one hour minimum
 - 6.8.2.4.2** Fluoropolymer (optional) – Extracted with methylene chloride
- 6.8.2.5** Water bath – Heated, with concentric ring cover, capable of maintaining a temperature within ∇ 2°C, installed in a fume hood
- 6.8.3** Nitrogen evaporation apparatus – Equipped with water bath controlled in the range of 30 - 60°C (N-Evap, Organomation Associates, Inc., South Berlin, MA, or equivalent), installed in a fume hood
- 6.8.4** Sample vials
 - 6.8.4.1** Amber glass, 2- to 5-mL with fluoropolymer-lined screw-cap
 - 6.8.4.2** Glass, 0.3-mL, conical, with fluoropolymer-lined screw or crimp cap
- 6.9** Gas chromatograph – Must have splitless or on-column injection port for capillary column, temperature program with isothermal hold, and must meet all of the performance specifications in Section 10.
 - 6.9.1** GC column – 60 ∇ 5-m long x 0.25 ∇ 0.02-mm ID; 0.10- μ m film DB-17, or equivalent
 - 6.9.1.1** The column must meet the following minimum retention time and resolution criteria, and must be adjusted or replaced when these criteria are not met:
 - 6.9.1.1.1** The retention time for methoxychlor must be greater than 39 minutes.
 - 6.9.1.1.2** trans-chlordane and trans-nonachlor (or the labeled analogs) must be uniquely resolved to a valley height less than 10 percent of the shorter of the two peaks.
 - 6.9.1.2** Endrin and DDT breakdown – The column must meet the endrin/DDT breakdown criteria in Section 10.6.2.3. Some GC injectors may be unable to meet requirements for endrin and DDT breakdown. This problem can be minimized by operating the injector at 200 - 205 °C, using a Pyrex (not quartz) methyl silicone deactivated injector liner, and deactivating the injector with dichlorodimethylsilane. A temperature

programmed injector has also been shown to minimize decomposition of labile substances such as endrin and DDT (Reference 10).

- 6.10** Mass spectrometer – 28- to 40-eV electron impact ionization, must be capable of selectively monitoring a minimum of 22 exact m/z's minimum at high resolution (greater than 8,000) during a period less than 1.5 seconds, and must meet all of the performance specifications in Section 10.
- 6.11** GC/MS interface – The mass spectrometer (MS) must be interfaced to the GC such that the end of the capillary column terminates within 1 cm of the ion source but does not intercept the electron or ion beams.
- 6.12** Data system – Capable of collecting, recording, storing, and processing MS data
 - 6.12.1** Data acquisition – The signal at each exact m/z must be collected repetitively throughout the monitoring period and stored on a mass storage device.
 - 6.12.2** Response factors and multipoint calibrations – The data system must record and maintain lists of response factors (response ratios for isotope dilution) and multipoint calibrations. Computations of relative standard deviation (RSD) are be used to test calibration linearity. Statistics on initial (Section 9.4) and ongoing (Section 15.6.4) performance should be computed and maintained, either on the instrument data system, or on a separate computer system.

7.0 Reagents and standards

- 7.1** pH adjustment and back-extraction
 - 7.1.1** Potassium hydroxide (KOH) – Dissolve 20 g reagent grade KOH in 100 mL reagent water.
 - 7.1.2** Sulfuric acid (H₂SO₄) – Reagent grade (specific gravity 1.84)
 - 7.1.3** Hydrochloric acid – Reagent grade, 6N
 - 7.1.4** Sodium chloride solution – Prepare at 5% (w/v) solution in reagent water
 - 7.1.4** Sodium sulfate solution – Prepare at 2% (w/v) in reagent water; pH adjust to 8.5 - 9.0 with KOH or H₂SO₄
- 7.2** Solution and tissue drying, municipal sludge extract back-extraction, and solvent evaporation (blowdown)
 - 7.2.1** Solution drying – Sodium sulfate, reagent grade, granular, anhydrous (Baker 3375, or equivalent), rinsed with methylene chloride (20 mL/g), baked at 400°C for 1 hour minimum, cooled in a desiccator, and stored in a pre-cleaned glass bottle with screw-cap that prevents moisture from entering. If, after heating, the sodium

sulfate develops a noticeable grayish cast (due to the presence of carbon in the crystal matrix), that batch of reagent is not suitable for use and should be discarded. Extraction with methylene chloride (as opposed to simple rinsing) and baking at a lower temperature may produce sodium sulfate that is suitable for use.

- 7.2.2** Tissue drying – Sodium sulfate, reagent grade, powdered, treated and stored as in Section 7.2.1
 - 7.2.3** Solution for back-extraction of municipal sludge extracts – Sodium sulfate solution: 2% (w/v) in reagent water, pH adjusted to pH 8.5 to 9.0 with KOH or H₂SO₄
 - 7.2.4** Prepurified nitrogen
- 7.3** Extraction
- 7.3.1** Solvents – Acetone, toluene, cyclohexane, hexane, methanol, methylene chloride, isooctane, and nonane; distilled in glass, pesticide quality, lot-certified to be free of interferences
 - 7.3.2** White quartz sand, 60/70 mesh – For Soxhlet/Dean-Stark extraction (Aldrich Chemical, Cat. No. 27-437-9, or equivalent). Bake at 450 – 500°C for 4 hours minimum.
- 7.4** GPC calibration solution – Prepare a solution containing 2.5 mg/mL corn oil, 0.05 mg/mL bis(2-ethylhexyl) phthalate (BEHP), 0.01 mg/mL methoxychlor, 0.002 mg/mL perylene, and 0.008 mg/mL sulfur, or at concentrations appropriate to the response of the detector.
- 7.5** Adsorbents for sample cleanup
- 7.5.1** Silica gel
 - 7.5.1.1** Activated silica gel – 100-200 mesh, Supelco 1-3651 (or equivalent), mesh, rinsed with methylene chloride, baked at 180±5 °C for a minimum of 1 hour, cooled in a desiccator, and stored in a precleaned glass bottle with screw-cap that prevents moisture from entering.
 - 7.5.1.1.1** 10% deactivated silica – Place 100 g of activated silica gel (Section 7.5.1.1) in a clean glass bottle or jar and add 10 g (or mL) of reagent water. Cap the bottle tightly to prevent moisture from entering or escaping.
 - 7.5.1.1.2** Tumble the bottle for 5 - 10 hours to thoroughly mix the water and silica. Keep bottle tightly sealed when silica is not being removed for use.

- 7.5.1.2** Acid silica gel (30% w/w) – Thoroughly mix 44 g of concentrated sulfuric acid with 100 g of activated silica gel in a clean container. Break up aggregates with a stirring rod until a uniform mixture is obtained. Store in a screw-capped bottle with fluoropolymer-lined cap.
- 7.5.1.3** Basic silica gel – Thoroughly mix 30 g of 1N sodium hydroxide with 100 g of activated silica gel in a clean container. Break up aggregates with a stirring rod until a uniform mixture is obtained. Store in a screw-capped bottle with fluoropolymer-lined cap.
- 7.5.1.4** Potassium silicate
- 7.5.1.4.1** Dissolve 56 g of high purity potassium hydroxide (Aldrich, or equivalent) in 300 mL of methanol in a 750- to 1000-mL flat-bottom flask.
- 7.5.1.4.2** Add 100 g of activated silica gel (Section 7.5.1.1) and a stirring bar, and stir on an explosion-proof hot plate at 60-70°C for 1-2 hours.
- 7.5.1.4.3** Decant the liquid and rinse the potassium silicate twice with 100-mL portions of methanol, followed by a single rinse with 100 mL of methylene chloride.
- 7.5.1.4.4** Spread the potassium silicate on solvent-rinsed aluminum foil and dry for 2-4 hours in a hood. Observe the precaution in Section 5.3.2.
- 7.5.1.4.5** Activate overnight at 200-250°C prior to use.
- 7.5.2** Anthropogenic isolation column – Pack the column in Section 6.7.4.3 from bottom to top with the following:
- 7.5.2.1** 2 g silica gel (Section 7.5.1.1)
- 7.5.2.2** 2 g potassium silicate (Section 7.5.1.4)
- 7.5.2.3** 2 g granular anhydrous sodium sulfate (Section 7.2.1)
- 7.5.2.4** 10 g acid silica gel (Section 7.5.1.2)
- 7.5.2.5** 2 g granular anhydrous sodium sulfate
- 7.5.3** Aminopropyl solid-phase extraction (SPE) column – 1 g aminopropyl-bonded silica (Varian NH₂, or equivalent).
-

Note: Other SPE columns (e.g., C_{18} octadecyl, cyanopropyl) may be used provided the laboratory establishes the elution conditions and meets the requirements in Section 9.2 with the SPE column as an integral part of the analysis.

7.5.4 Florisil column

- 7.5.4.1 Florisil – PR grade, 60-100 mesh (U.S. Silica Corp, Berkeley Springs, WV, or equivalent). Alternatively, prepacked Florisil columns may be used. Use the following procedure for Florisil activation and column packing.
- 7.5.4.2 Fill a clean 1- to 2-L bottle 1/2 to 2/3 full with Florisil and place in an oven at 130-150°C for a minimum of three days to activate the Florisil.
- 7.5.4.3 Immediately prior to use, dry pack a 300-mm x 22-mm ID glass column (Section 6.7.4.3) bottom to top with 0.5-1.0 cm of warm to hot anhydrous sodium sulfate (Section 7.2.1), 10-10.5 cm of warm to hot activated Florisil (Section 7.5.4.2), and 1-2 cm of warm to hot anhydrous sodium sulfate. Allow the column to cool and pre-elute immediately with 100 mL of n-hexane. Keep column wet with hexane to prevent water from entering.
- 7.5.4.4 Using the procedure in Section 13.7.3, establish the elution pattern for each carton of Florisil or each lot of Florisil columns received.

7.5.5 Alumina column

- 7.5.5.1 Alumina – Neutral, Brockman Activity I, 80-200 mesh (Fisher Scientific Certified, or equivalent). Heat for 16 hours at 400 to 450°C. Seal and cool to room temperature. Add 7% (W/W) reagent water and tumble for 1 to 2 hours. Keep bottle tightly sealed.
- 7.5.5.2 Immediately prior to use, partially fill a 150-mm x 8-mm ID glass column (Section 6.7.4.1) with n-hexane. Pack the column bottom to top with 0.5 - 1 cm of warm to hot anhydrous sodium sulfate (Section 7.2.1), 10 - 10.5 cm alumina (Section 7.5.5.1) and 1 - 1.5 cm of warm to hot anhydrous sodium sulfate. Allow the column to cool and pre-elute immediately with 100 mL of hexane. Keep column wet with hexane to prevent moisture from entering.

7.6 Reference matrices – Matrices in which the pesticides and interfering compounds are not detected by this Method

- 7.6.1 Reagent water – Bottled water purchased locally, or prepared by passage through activated carbon

- 7.6.2** High-solids reference matrix – Playground sand or similar material. Prepared by extraction with methylene chloride and/or baking at 450°C for a minimum of 4 hours.
- 7.6.3** Paper reference matrix – Glass-fiber filter, Gelman type A, or equivalent. Cut paper to simulate the surface area of the paper sample being tested.
- 7.6.4** Tissue reference matrix – Corn or other vegetable oil.
- 7.6.5** Other matrices – This Method may be verified on any reference matrix by performing the tests given in Section 9.2. Ideally, the matrix should be free of the pesticides, but in no case must the background level of the pesticides in the reference matrix exceed the minimum levels in Table 1. If low background levels of the pesticides are present in the reference matrix, the spike level of the analytes used in Section 9.2 should be increased to provide a spike-to-background ratio of approximately 5 (Reference 11).
- 7.7** Standard solutions – Prepare from materials of known purity and composition or purchase as solutions or mixtures with certification to their purity, concentration, and authenticity. If the chemical purity is 98 % or greater, the weight may be used without correction to calculate the concentration of the standard. Observe the safety precautions in Section 5 and the recommendation in Section 5.1.2.
- 7.7.1** For preparation of stock solutions from neat materials, dissolve an appropriate amount of assayed reference material in solvent. For example, weigh 10 to 20 mg of lindane to three significant figures in a 10-mL ground-glass-stoppered volumetric flask and fill to the mark with nonane. After the compound is completely dissolved, transfer the solution to a clean 15-mL vial with fluoropolymer-lined cap.
- 7.7.2** When not being used, store standard solutions in the dark at room temperature in screw-capped vials with fluoropolymer-lined caps. Place a mark on the vial at the level of the solution so that solvent loss by evaporation can be detected. Replace the solution if solvent loss has occurred.
- 7.8** Native (unlabeled) stock solutions
- 7.8.1** Native stock solution – Prepare to contain the pesticides at the concentrations shown in Table 3, or purchase prepared solutions. If additional pesticides are to be determined, include the additional native compounds in this stock solution.
- 7.8.2** Stock solutions should be checked for signs of degradation (e.g., discoloration, precipitation) prior to preparing calibration or performance test standards. Reference standards that can be used to determine the accuracy of standard solutions are available from several vendors.
- 7.9** Labeled compound stock solutions (Table 3)

- 7.9.1** Labeled pesticide stock solution – Prepare the labeled pesticides in isooctane or nonane at the concentrations in Table 3 or purchase prepared standards. If additional pesticides are to be determined by isotope dilution, include the additional labeled compounds in this stock solution.
- 7.9.2** Labeled injection internal standard stock solution – Prepare labeled PCB 52 in nonane or isooctane at the concentration shown in Table 3, or purchase a prepared standard.
- 7.10** Calibration standards – Combine and dilute the solutions in Sections 7.8 and 7.9 to produce the calibration solutions in Table 4 or purchase prepared standards for the CS-1 to CS-6 set of calibration solutions. These solutions permit the relative response (labeled to native) and response factor to be measured as a function of concentration. The CS-4 standard is used for calibration verification (VER).
- 7.11** Native IPR/OPR standard spiking solution – Used for determining initial precision and recovery (IPR; Section 9.2) and ongoing precision and recovery (OPR; Section 15.6). Dilute the Native stock solution (Section 7.8.1) with acetone to produce the concentrations of the pesticides as shown in Table 3. When 1 mL of this solution is spiked into the IPR (Section 9.2.1) or OPR (Section 15.6) and concentrated to a final volume of 20 μL , the concentration of the pesticides in the final volume will be either 8 or 20 ng/mL (pg/ ΦL), as shown in Table 3. Prepare only the amount necessary for each reference matrix with each sample batch.
- 7.12** Labeled standard spiking solution – This solution is spiked into each sample (Section 9.3) and into the IPR (Section 9.2.1), OPR (Section 15.6), and blank (Section 9.5) to measure recovery. Dilute the Labeled pesticide stock solution (Section 7.9.1) with acetone to produce the concentrations of the labeled compounds shown in Table 3. When 1 mL of this solution is spiked into an IPR, OPR, blank, or sample and concentrated to a final extract volume of 20 μL , the concentration in the final volume will be as shown in Table 3. Prepare only the amount necessary for each reference matrix with each sample batch.
- 7.13** Endrin/4,4'-DDT breakdown solution – Prepare a solution to contain 100 ng/mL (pg/ μL) of DDT and 50 ng/mL (pg/ μL) of endrin in isooctane or nonane. This solution is to determine endrin/4,4'-DDT breakdown in Sections 10.6 and 15.5.
- 7.14** Labeled injection internal standard spiking solution – This solution is added to each concentrated extract prior to injection into the HRGC/HRMS. Dilute the Labeled injection internal standard stock solution (Section 7.9.2) in nonane to produce a concentration of the injection internal standards at 800 ng/mL, as shown in Table 3. When 2 μL of this solution is spiked into a 20 μL extract, the concentration of each injection internal standard will be nominally 80 ng/mL (pg/ μL), as shown in Table 3.

Note: *The addition of 2 μL of the Labeled injection internal standard spiking solution to a 20 μL final extract has the effect of diluting the concentration of the components in the extract by 10%.*

Provided all calibration solutions and all extracts undergo this dilution as a result of adding the Labeled injection internal standard spiking solution, the effect of the 10% solution is compensated, and correction for this dilution should not be made.

- 7.15** QC Check Sample – A QC Check Sample should be obtained from a source independent of the calibration standards. Ideally, this check sample would be a certified Standard Reference Material (SRM) containing the pesticides in known concentrations in a sample matrix similar to the matrix under test. The National Institute of Standards and Technology (NIST) in Gaithersburg, Maryland has SRMs, and the Institute for National Measurement Standards of the National Research Council of Canada in Ottawa has certified reference materials (CRMs), for pesticides in various matrices.
- 7.16** Stability of solutions – Standard solutions used for quantitative purposes (Sections 7.8 - 7.14) should be assayed periodically (e.g., every 6 months) against SRMs from NIST (if available), or certified reference materials from a source that will attest to the authenticity and concentration, to assure that the composition and concentrations have not changed.

8.0 Sample collection, preservation, storage, and holding times

- 8.1** Collect samples in amber glass containers following conventional sampling practices (Reference 12); collect field and trip blanks as necessary to validate the sampling.
- 8.2** Aqueous samples
- 8.2.1** Samples that flow freely are collected as grab samples or in refrigerated bottles using automatic sampling equipment. Collect 1-L. If high concentrations of the pesticides are expected, collect a smaller volume (e.g., 100 mL) in addition to the 1-L sample. Do not rinse the bottle with sample before collection.
- 8.2.2** If residual chlorine is present, add 80 mg sodium thiosulfate per liter of water. Any method suitable for field use may be employed to test for residual chlorine (Reference 9).
- 8.2.3** Maintain aqueous samples in the dark at <6°C from the time of collection until receipt at the laboratory (see 40 CFR 136.6(e), Table II). If the sample will be frozen, allow room for expansion.
- 8.2.4** If the sample will not be analyzed within 72 hours, adjust the pH to a range of 5.0 to 9.0 with sodium hydroxide or sulfuric acid solution. Record the volume of acid or base used.
- 8.3** Solid, mixed-phase, semi-solid, and oily samples, excluding tissue.
- 8.3.1** Collect samples as grab samples using wide-mouth jars. Collect a sufficient amount of wet material to produce a minimum of 20 g of solids.

8.3.2 Maintain solid, semi-solid, oily, and mixed-phase samples in the dark at <6°C from the time of collection until receipt at the laboratory. Store solid, semi-solid, oily, and mixed-phase samples in the dark at less than -10°C.

8.4 Fish and other tissue samples

8.4.1 Fish may be cleaned, filleted, or processed in other ways in the field, such that the laboratory may expect to receive whole fish, fish fillets, or other tissues for analysis.

8.4.2 Collect fish, wrap in aluminum foil, and maintain at <6°C from the time of collection until receipt at the laboratory, to a maximum time of 24 hours. If a longer transport time is necessary, freeze the sample. Ideally, fish should be frozen upon collection and shipped to the laboratory under dry ice.

8.4.3 Freeze tissue samples upon receipt at the laboratory and maintain in the dark at less than -10°C until prepared. Maintain unused sample in the dark at less than -10°C.

8.4.4 Store sample extracts in the dark at less than -10°C until analyzed.

8.5 Holding times – See 40 CFR 136.3(e) Table II

8.5.1 Aqueous samples – Extract within 7 days of collection, and analyze within 40 days of extraction.

8.5.2 Solid, mixed-phase, semi-solid, tissue, and oily samples – Extract and analyze within 1 year of collection. If a sample is to be stored for more than 14 days, and results are to be reported in solids units, either hermetically seal the sample container or determine the moisture content upon receipt and immediately prior to analysis. Adjust the final concentration based on the original moisture content.

9.0 Quality assurance/quality control

9.1 Each laboratory that uses this Method is required to operate a formal quality assurance program (Reference 14). The minimum requirements of this program consist of an initial demonstration of laboratory capability, analysis of samples spiked with labeled compounds to evaluate and document data quality, and analysis of standards and blanks as tests of continued performance. Laboratory performance is compared to established performance criteria to determine if the results of analyses meet the performance characteristics of the Method.

If the Method is to be applied to a sample matrix other than water (e.g., soils, filter cake, compost, tissue) the most appropriate alternate reference matrix (Sections 7.6.2 - 7.6.5 and 7.15) is substituted for the reagent water matrix (Section 7.6.1) in all performance tests.

- 9.1.1** The laboratory must make an initial demonstration of the ability to generate acceptable precision and recovery with this Method. This demonstration is given in Section 9.2.
- 9.1.2** In recognition of advances that are occurring in analytical technology, and to overcome matrix interferences, the laboratory is permitted certain options to improve separations or lower the costs of measurements. These options include alternate extraction, concentration, and cleanup procedures, and changes in columns and detectors (see also 40 CFR 136.6). Alternate determinative techniques, such as the substitution of spectroscopic or immuno-assay techniques, and changes that degrade Method performance, are not allowed. If an analytical technique other than the techniques specified in this Method is used, that technique must have a specificity equal to or greater than the specificity of the techniques in this Method for the analytes of interest.
- 9.1.2.1** Each time a modification is made to this Method, the laboratory is required to repeat the procedure in Section 9.2. If the detection limit of the Method will be affected by the change, the laboratory is required to demonstrate that the MDLs (40 CFR Part 136, Appendix B) are lower than one-third the regulatory compliance level or the MDLs in this Method, whichever are greater. If calibration will be affected by the change, the instrument must be recalibrated per Section 10. Once the modification is demonstrated to produce results equivalent or superior to results produced by this Method as written, that modification may be used routinely thereafter, so long as the other requirements in this Method are met (e.g., labeled compound recovery).
- 9.1.2.2** The laboratory is required to maintain records of modifications made to this Method. These records include the following, at a minimum:
- 9.1.2.2.1** The names, titles, addresses, and telephone numbers of the analyst(s) that performed the analyses and modification, and of the quality control officer that witnessed and will verify the analyses and modifications.
- 9.1.2.2.2** A listing of pollutant(s) measured, by name and CAS Registry number.
- 9.1.2.2.3** A narrative stating reason(s) for the modifications.
- 9.1.2.2.4** Results from all quality control (QC) tests comparing the modified method to this Method, including:
- Calibration (Section 10)
 - Calibration verification (Section 15.3)
 - Initial precision and recovery (Section 9.2)
 - Labeled compound recovery (Section 9.3)

- e) Analysis of blanks (Section 9.5)
- f) Accuracy assessment (Section 9.4)

9.1.2.2.5 Data that will allow an independent reviewer to validate each determination by tracing the instrument output (peak height, area, or other signal) to the final result. These data are to include:

- a) Sample numbers and other identifiers
- b) Extraction dates
- c) Analysis dates and times
- d) Analysis sequence/run chronology
- e) Sample weight or volume (Section 11)
- f) Extract volume prior to each cleanup step (Section 13)
- g) Extract volume after each cleanup step (Section 13)
- h) Final extract volume prior to injection (Section 14)
- i) Injection volume (Sections 10.3 and 14.3)
- j) Dilution data, differentiating between dilution of a sample or extract (Section 17.5)
- k) Instrument and operating conditions
- l) Column (dimensions, liquid phase, solid support, film thickness, etc)
- m) Operating conditions (temperatures, temperature program, flow rates)
- n) Detector (type, operating conditions, etc)
- o) Chromatograms, printer tapes, and other recordings of raw data
- p) Quantitation reports, data system outputs, and other data to link the raw data to the results reported

9.1.2.3 Alternate HRGC columns and column systems – If a column or column system alternate to those specified in this Method is used, that column or column system must meet the requirements in Section 6.9.1.

9.1.3 Analyses of method blanks are required to demonstrate freedom from contamination (Section 4.3). The procedures and criteria for analysis of a method blank are given in Sections 9.5 and 15.7.

9.1.4 The laboratory must spike all samples with labeled compounds to monitor Method performance. This test is described in Section 9.3. When results of these spikes indicate atypical Method performance for samples, the samples are diluted to bring Method performance within acceptable limits. Procedures for dilution are given in Section 17.5.

9.1.5 The laboratory must, on an ongoing basis, demonstrate through calibration verification and the analysis of the ongoing precision and recovery standard (OPR) and

blanks that the analytical system is in control. These procedures are given in Sections 15.1 through 15.7.

- 9.1.6** The laboratory should maintain records to define the quality of data generated. Development of accuracy statements is described in Sections 9.4 and 15.6.4.
- 9.2** Initial precision and recovery (IPR) – To establish the ability to generate acceptable precision and recovery, the laboratory must perform the following operations:
- 9.2.1** For low solids (aqueous) samples, extract, concentrate, and analyze four 1-L aliquots of reagent water spiked with 1 mL each of the Native spiking solution (Section 7.11) and the Labeled spiking solution (Section 7.12), according to the procedures in Sections 11 through 18. For an alternate sample matrix, four aliquots of the alternate reference matrix (Sections 7.6.1 - 7.6.5) are used. All sample processing steps that are to be used for processing samples, including preparation (Section 11), extraction (Section 12), and cleanup (Section 13), must be included in this test.
- 9.2.2** Using results of the set of four analyses, compute the average percent recovery (X) of the extracts and the relative standard deviation (RSD) of the concentration for each compound, by isotope dilution for pesticides with a labeled analog, and by internal standard for pesticides without a labeled analog and for the labeled compounds.
- 9.2.3** For each pesticide and labeled compound, compare RSD and X with the corresponding limits for initial precision and recovery in Table 5. If RSD and X for all compounds meet the acceptance criteria, system performance is acceptable and analysis of blanks and samples may begin. If, however, any individual RSD exceeds the precision limit or any individual X falls outside the range for recovery, system performance is unacceptable for that compound. Correct the problem and repeat the test (Section 9.2).
- 9.3** To assess Method performance on the sample matrix, the laboratory must spike all samples with the Labeled spiking solution (Section 7.12).
- 9.3.1** Analyze each sample according to the procedures in Sections 11 through 18.
- 9.3.2** Compute the percent recovery of the labeled pesticides using the internal standard method (Section 17.2).
- 9.3.3** The recovery of each labeled compound must be within the limits in Table 5. If the recovery of any compound falls outside of these limits, Method performance is unacceptable for that compound in that sample. Additional cleanup procedures must then be employed to attempt to bring the recovery within the normal range. If the recovery cannot be brought within the normal range after all cleanup procedures have been employed, water samples are diluted and smaller amounts of soils, sludges, sediments, and other matrices are analyzed per Section 18.

- 9.4** It is suggested but not required that recovery of labeled compounds from samples be assessed and records maintained.
- 9.4.1** After the analysis of 30 samples of a given matrix type (water, soil, sludge, pulp, etc.) for which the labeled compounds pass the tests in Section 9.3, compute the average percent recovery (R) and the standard deviation of the percent recovery (S_R) for the labeled compounds only. Express the assessment as a percent recovery interval from $R - 2S_R$ to $R + 2S_R$ for each matrix. For example, if $R = 90\%$ and $S_R = 10\%$ for five analyses of pulp, the recovery interval is expressed as 70 to 110%.
- 9.4.2** Update the accuracy assessment for each labeled compound in each matrix on a regular basis (e.g., after each five to ten new measurements).
- 9.5** Method blanks – A reference matrix Method blank is analyzed with each sample batch (Section 4.3) to demonstrate freedom from contamination. The matrix for the Method blank must be similar to the sample matrix for the batch, e.g., a 1-L reagent water blank (Section 7.6.1), high-solids reference matrix blank (Section 7.6.2), paper matrix blank (Section 7.6.3); tissue blank (Section 7.6.4), or alternate reference matrix blank (Section 7.6.5).
- 9.5.1** Spike 1.0 mL each of the Labeled spiking solution (Section 7.12) into the Method blank, according to the procedures in Sections 11 through 18. Prepare, extract, clean up, and concentrate the Method blank. Analyze the blank immediately after analysis of the OPR (Section 15.6) to demonstrate freedom from contamination.
- 9.5.2** If any pesticide (Table 1) is found in the blank at greater than the minimum level (Table 1) or one-third the regulatory compliance limit, whichever is greater; or if any potentially interfering compound is found in the blank at the minimum level for each pesticide in Table 1 (assuming a response factor of 1 relative to the quantitation reference in Table 2 for a potentially interfering compound; i.e., a compound not listed in this Method), analysis of samples must be halted until the sample batch is re-extracted and the extracts re-analyzed, and the blank associated with the sample batch shows no evidence of contamination at these levels. All samples must be associated with an uncontaminated Method blank before the results for those samples may be reported or used for permitting or regulatory compliance purposes.
- 9.6** QC Check Sample – Analyze the QC Check Sample (Section 7.15) periodically to assure the accuracy of calibration standards and the overall reliability of the analytical process. It is suggested that the QC Check Sample be analyzed at least quarterly.
- 9.7** The specifications contained in this Method can be met if the apparatus used is calibrated properly and then maintained in a calibrated state. The standards used for calibration (Section 10), calibration verification (Section 15.3), and for initial (Section 9.2) and ongoing (Section 15.6) precision and recovery should be identical, so that the most precise results will be obtained. A GC/HRMS instrument will provide the most reproducible

results if dedicated to the settings and conditions required for determination of pesticides by this Method.

- 9.8** Depending on specific program requirements, field replicates may be collected to determine the precision of the sampling technique, and spiked samples may be required to determine the accuracy of the analysis when the internal standard method is used.

10.0 Calibration

- 10.1** Establish the operating conditions necessary to meet the retention times (RTs) and relative retention times (RRTs) for the pesticides in Table 2.

10.1.1 Suggested operating conditions:

GC conditions

Injector	Split/splitless, 2 min
Carrier gas	Helium @ 200 kPa
Injector temperature	180 - 220°C or temperature programmed
Maximum column temperature	300°C

GC Temperature program

Initial temperature and hold	50°C for 1 minute
Initial ramp	50 - 180°C @ 10°C per minute
Second hold	180°C for 0 minute
Second ramp	180 - 200°C @ 1.5°C per minute
Third hold	200°C for 2 minutes
Third ramp	200 - 295°C @ 6°C per minute
Final hold	295°C for 1 minutes or until methoxychlor elutes
Interface temperature	290°C

Mass spectrometer conditions

Source temperature	250°C
Electron energy	35 eV
Trap current	500 - 900 Φ A
Mass resolution	8000
Detector potential	340 - 400 V

10.1.1.1 All portions of the column that connect the GC to the ion source should remain at or above the interface temperature during analysis to preclude condensation of less volatile compounds.

10.1.1.2 The GC conditions may be optimized for compound separation and sensitivity. Once optimized, the same GC conditions must be used for the analysis of all standards, blanks, IPR and OPR standards, and samples.

10.1.2 Retention time calibration for the native and labeled pesticides

10.1.2.1 Inject the CS-4 calibration standard (Section 7.10 and Table 4). Establish the beginning and ending retention times for the scan descriptors in Table 6. Scan descriptors other than those listed in Table 6 may be used provided the MLs in Table 1 are met. Store the retention time (RT) and relative retention time (RRT) for each compound in the data system.

10.1.2.2 The absolute retention time of methoxychlor must exceed 39 minutes on the DB-17 column; otherwise, the GC temperature program must be adjusted and this test repeated until the minimum retention time criterion is met. If a GC column or column system alternate to the DB-17 column is used, a similar minimum retention time specification must be established for the alternate column or column systems so that interferences that may be encountered in environmental samples will be resolved from the analytes of interest. This specification is deemed to be met if the retention time of methoxychlor is greater than 39 minutes on such alternate column.

10.2 Mass spectrometer (MS) resolution

10.2.1 Using PFK (or other reference substance) and a molecular leak, tune the instrument to meet the minimum required resolving power of 8,000 (10% valley) at m/z 280.9825 or other significant PFK fragment in the range of 250 - 300. For each descriptor (Table 6), monitor and record the resolution and exact m/z 's of three to five reference peaks covering the mass range of the descriptor. The level of PFK (or other reference substance) metered into the HRMS during analyses should be adjusted so that the amplitude of the most intense selected lock-mass m/z signal (regardless of the descriptor number) does not exceed 10% of the full-scale deflection for a given set of detector parameters. Under those conditions, sensitivity changes that might occur during the analysis can be more effectively monitored.

Note: *Different lots and types of PFK can contain varying levels of contamination, and excessive PFK (or other reference substance) may cause noise problems and contamination of the ion source necessitating increased frequency of source cleaning.*

- 10.2.2** The analysis time for the pesticides may exceed the long-term mass stability of the mass spectrometer. Because the instrument is operated in the high-resolution mode, mass drifts of a few ppm (e.g., 5 ppm in mass) can have serious adverse effects on instrument performance. Therefore, mass-drift correction is mandatory and a lock-mass m/z from perfluorokerosene (PFK) or other reference substance is used for drift correction. The lock-mass m/z is dependent on the exact m/z 's monitored within each descriptor, as shown in Table 6. The deviation between each monitored exact m/z and the theoretical m/z (Table 6) must be less than 5 ppm.
- 10.2.3** Obtain a selected ion current profile (SICP) at the two exact m/z 's specified in Table 6 and at $\geq 8,000$ resolving power for each native and labeled pesticide. Because of the extensive mass range covered in each function, it may not be possible to maintain 8,000 resolution throughout the mass range during the function. Therefore, resolution must be $\geq 6,000$ throughout the mass range and must be $\geq 8,000$ in the center of the mass range for each function.
- 10.2.4** If the HRMS has the capability to monitor resolution during the analysis, it is acceptable to terminate the analysis when the resolution falls below the minimum (Section 10.2.1 and 10.2.3) to save re-analysis time.
- 10.3** Ion abundance ratios, minimum levels, and signal-to-noise ratios during calibration. Choose an injection volume of either 1 or 2 μL , consistent with the capability of the HRGC/HRMS instrument. Inject a 1 or 2 μL aliquot of the CS-1 calibration solution (Table 4) using the GC conditions in Section 10.1.1.
- 10.3.1** Measure the SICP areas for each pesticide, and compute the ion abundance ratios at the exact m/z 's specified in Table 6. Compare the computed ratio to the theoretical ratio given in Table 6.
- 10.3.1.1** The exact m/z 's to be monitored in each descriptor are shown in Table 6. Each group or descriptor must be monitored in succession as a function of GC retention time to ensure that the pesticides are detected. Additional m/z 's may be monitored in each descriptor, and the m/z 's may be divided among more than the descriptors listed in Table 6, provided that the laboratory is able to monitor the m/z 's of all pesticides that may elute from the GC in a given RT window.
- 10.3.1.2** The mass spectrometer must be operated in a mass-drift correction mode, using PFK (or other reference substance) to provide lock m/z 's. The lock mass for each group of m/z 's is shown in Table 6. Each lock mass must be monitored and must not vary by more than $\pm 20\%$ throughout its respective retention time window. Variations of lock mass by more than 20% indicate the presence of co-eluting interferences that raise the source pressure and may significantly reduce the sensitivity of the mass spectrometer. Re-injection of another aliquot of the sample extract may not resolve the problem and additional cleanup of the extract may be

required to remove the interference. A lock mass interference or suppression in a retention time region in which pesticides and labeled compounds do not elute may be ignored.

- 10.3.2** All pesticides and labeled compounds in the CS-1 standard must be within the QC limits in Table 6 for their respective ion abundance ratios; otherwise, the mass spectrometer must be adjusted and this test repeated until the m/z ratios fall within the limits specified. If the adjustment alters the resolution of the mass spectrometer, resolution must be verified (Section 10.2.1) prior to repeat of the test.
- 10.3.3** Verify that the HRGC/HRMS instrument meets the minimum levels (MLs) in Table 1. The peaks representing the pesticides and labeled compounds in the CS-1 calibration standard must have signal-to-noise ratios (S/N) ≥ 3 ; otherwise, the mass spectrometer must be adjusted and this test repeated until the minimum levels in Table 1 are met.
- 10.4** Calibration by isotope dilution – Isotope dilution is used for calibration of the native pesticides for which a labeled analog is available. The reference compound for each native compound is its labeled analog, as listed in Table 2. A 6-point calibration encompassing the concentration range is prepared for each native compound.
- 10.4.1** For the pesticides determined by isotope dilution, the relative response (RR) (labeled to native) vs. concentration in the calibration solutions (Table 4) is computed over the calibration range according to the procedures described below. Five calibration points are employed for less-sensitive HRMS instruments (e.g., VG 70); five or six points may be employed for more-sensitive instruments (e.g., Micromass Autospec Ultima).
- 10.4.2** Determine the response of each pesticide relative to its labeled analog using the area responses of both the primary and secondary exact m/z's specified in Table 6, for each calibration standard. Use the labeled compounds listed in Table 2 as the quantitation reference and the two exact m/z's listed in Table 6 for quantitation. The areas at the two exact m/z's for the compound is summed and divided by the summed area of the two exact m/z's for the quantitation reference.

Note: Both exact m/z's are used as reference to reduce the effect of an interference at a single m/z. Other quantitation references and procedures may be used provided that the results produced are as accurate as results produced by the quantitation references and procedures described in this Section.

- 10.4.3** Calibrate the native compounds with a labeled analog using the following equation:

$$RR = \frac{(A_{1_n} + A_{2_n}) C_l}{(A_{1_l} + A_{2_l}) C_n}$$

Where:

A_{1_n} and A_{2_n} = The areas of the primary and secondary m/z's for the pesticide

- A_{1_l} and A_{2_l} = The areas of the primary and secondary m/z's for the labeled compound.
- C_l = The concentration of the labeled compound in the calibration standard (Table 4).
- C_n = The concentration of the native compound in the calibration standard (Table 4).

10.4.4 To calibrate the analytical system by isotope dilution, inject calibration standards CS-2 through CS-6 (Section 7.10 and Table 4) for a less sensitive instrument (e.g. VG 70) or CS-1 through CS-6 for a more sensitive instrument (e.g., Micromass Autospec Ultima). Use a volume identical to the volume chosen in Section 10.3, the procedure in Section 14, and the conditions in Section 10.1.1. Compute and store the relative response (RR) for each pesticide at each concentration. Compute the average (mean) RR and the RSD of the 6 RRs.

10.4.5 Linearity – If the RRs for any pesticide are constant (less than 20% RSD), the average RR may be used for that pesticide; otherwise, the complete calibration curve for that pesticide must be used over the calibration range.

10.5 Calibration by internal standard – Internal standard calibration is applied to determination of the native pesticides for which a labeled compound is not available, and to determination of the labeled compounds for performance tests and intra-laboratory statistics (Sections 9.4 and 15.6.4). The reference compound for each compound is listed in Table 2. For the labeled compounds, calibration is performed at a single concentration using data from the 6 points in the calibration (Section 10.4).

10.5.1 Response factors – Internal standard calibration requires the determination of response factors (RF) defined by the following equation:

$$RF = \frac{(A_{1_s} + A_{2_s}) C_{is}}{(A_{1_{is}} + A_{2_{is}}) C_s}$$

Where:

- A_{1_s} and A_{2_s} = The areas of the primary and secondary m/z's for the pesticide.
- $A_{1_{is}}$ and $A_{2_{is}}$ = The areas of the primary and secondary m/z's for the internal standard.
- C_{is} = The concentration of the internal standard (Table 4).
- C_s = The concentration of the compound in the calibration standard (Table 4).

10.5.2 To calibrate the analytical system for pesticides that do not have a labeled analog, and for the labeled compounds, use the data from the 6-point calibration (Section 10.4.4 and Table 4).

10.5.3 Compute and store the response factor (RF) for all native pesticides that do not have a labeled analog and for the labeled compounds. Use the labeled compounds

listed in Table 2 as the quantitation reference and the two exact m/z's listed in Table 6 for quantitation. For example, the areas at the two exact m/z's for the compound is summed and divided by the summed area of the two exact m/z's for the quantitation reference.

- 10.5.4** Compute and store the response factor (RF) for the labeled compounds using the Labeled injection internal standard as the quantitation reference, as given in Table 2.
- 10.5.5** Linearity – If the RFs for any pesticide are constant (less than 35% RSD), the average RF may be used for that pesticide; otherwise, the complete calibration curve for that pesticide must be used over the calibration range.
- 10.6** Endrin/4,4'-DDT breakdown – This test is run after calibration (Section 10.4 and 10.5) or calibration verification (Section 15.3) to assure that the labile pesticides do not decompose in the GC.

10.6.1 Inject the endrin/4,4'-DDT breakdown solution (Section 7.13) using the same volume chosen in Section 10.3.

10.6.2 Measure and sum the peak areas for both exact m/z's separately for 4,4'-DDD, 4,4'-DDE, 4,4'-DDT, endrin, endrin aldehyde, and endrin ketone using the calibration data from Section 10.4.

10.6.2.1 Add the summed peak areas for endrin aldehyde and endrin ketone and separately add the peak areas for 4,4'-DDD and 4,4'-DDE.

10.6.2.2 Calculate the endrin and 4,4'-DDT breakdown as follows:

$$\text{Endrin breakdown (percent)} = \frac{(\text{areas for endrin aldehyde} + \text{endrin ketone}) \times 100}{\text{areas for endrin}}$$

$$4,4\text{'-DDT breakdown (percent)} = \frac{(\text{areas for } 4,4\text{'-DDD} + 4,4\text{'-DDE}) \times 100}{\text{areas for } 4,4\text{'-DDT}}$$

10.6.2.3 If the breakdown of endrin or 4,4'-DDT exceeds 20 percent, endrin or 4,4'-DDT is decomposing. If decomposition greater than 20 percent of either endrin or 4,4'-DDT occurs, clean and recondition the injector, break off a short section of the inlet end of the column, or alter the GC conditions to reduce the decomposition to where the 20 percent criterion is met (see Section 6.9.1.2).

11.0 Sample preparation

11.1 Sample preparation involves modifying the physical form of the sample so that the pesticides can be extracted efficiently. In general, the samples must be in a liquid form or

in the form of finely divided solids in order for efficient extraction to take place. Table 7 lists the phases and suggested quantities for extraction of various sample matrices.

For samples known or expected to contain high levels of the pesticides, the smallest sample size representative of the entire sample should be used (see Section 18). For all samples, the blank and IPR/OPR aliquots must be processed through the same steps as the sample to check for contamination and losses in the preparation processes.

- 11.1.1** For samples that contain particles, percent solids and particle size are determined using the procedures in Sections 11.2 and 11.3, respectively.
- 11.1.2** Aqueous samples – Because the pesticides may be bound to suspended particles, the preparation of aqueous samples is dependent on the solids content of the sample.
 - 11.1.2.1** Aqueous samples containing one percent solids or less are prepared per Section 11.4 and extracted directly using one of the extraction techniques in Section 12.2.
 - 11.1.2.2** For aqueous samples containing greater than one percent solids, a sample aliquot sufficient to provide 10 g of dry solids is used, as described in Section 11.5.
- 11.1.3** Solid Samples - Solid samples are prepared using the procedure described in Section 11.5 followed by extraction using the SDS procedure in Section 12.3.
- 11.1.4** Multi-phase samples – The phase(s) containing the pesticides is separated from the non-pesticide phase using pressure filtration and centrifugation, as described in Section 11.6. The pesticides will be in the organic phase in a multi-phase sample in which an organic phase exists.
- 11.1.5** Procedures for grinding, homogenization, and blending of various sample phases are given in Section 11.7.
- 11.1.6** Tissue samples – Preparation procedures for fish and other tissues are given in Section 11.8.

11.2 Determination of percent suspended solids

Note: *This aliquot is used for determining the solids content of the sample, not for pesticide determination.*

- 11.2.1** Aqueous liquids and multi-phase samples consisting of mainly an aqueous phase.
 - 11.2.1.1** Desiccate and weigh a GF/D filter (Section 6.5.3) to three significant figures.

11.2.1.2 Filter 10.0 \pm 0.02 mL of well-mixed sample through the filter.

11.2.1.3 Dry the filter a minimum of 12 hours at 110 \pm 5°C and cool in a desiccator.

11.2.1.4 Calculate percent solids as follows:

$$\% \text{ Solids} = \frac{\text{Weight of sample aliquot after drying (g)} - \text{weight of filter (g)}}{10 \text{ g}} \times 100$$

11.2.2 Non-aqueous liquids, solids, semi-solid samples, and multi-phase samples in which the main phase is not aqueous; but not tissues.

11.2.2.1 Weigh 5 to 10 g of sample to three significant figures in a tared beaker.

11.2.2.2 Dry a minimum of 12 hours at 110 \pm 5°C, and cool in a desiccator.

11.2.2.3 Calculate percent solids as follows:

$$\% \text{ Solids} = \frac{\text{Weight of sample aliquot after drying}}{\text{Weight of sample aliquot before drying}} \times 100$$

11.3 Estimation of particle size

11.3.1 Spread the dried sample from Section 11.2.1.3 or 11.2.2.2 on a piece of filter paper or aluminum foil in a fume hood or glove box.

11.3.2 Estimate the size of the particles in the sample. If the size of the largest particles is greater than 1 mm, the particle size must be reduced to 1 mm or less prior to extraction using the procedures in Section 11.7.

11.4 Preparation of aqueous samples containing one percent suspended solids or less.

11.4.1 Aqueous samples containing one percent suspended solids or less are prepared using the procedure below and extracted using the one of the extraction techniques in Section 12.2.

11.4.2 Preparation of sample and QC aliquots

11.4.2.1 Mark the original level of the sample on the sample bottle for reference. Weigh the sample plus bottle to \pm 1 g.

11.4.2.2 Spike 1.0 mL of the Labeled pesticide spiking solution (Section 7.12) into the sample bottle. Cap the bottle and mix the sample by shaking. Allow the sample to equilibrate for 1 to 2 hours, with occasional shaking.

- 11.4.2.3** For each sample or sample batch (to a maximum of 20 samples) to be extracted during the same 12-hour shift, place two 1.0-L aliquots of reagent water in clean sample bottles or flasks.
- 11.4.2.4** Spike 1.0 mL of the Labeled pesticide spiking solution (Section 7.12) into both reagent water aliquots. One of these aliquots will serve as the Method blank.
- 11.4.2.5** Spike 1.0 mL of the Native pesticide spiking solution (Section 7.11) into the remaining reagent water aliquot. This aliquot will serve as the OPR (Section 15.6).
- 11.4.2.6** For extraction using SPE, add 5 mL of methanol to the sample and QC aliquots. Cap and shake the sample and QC aliquots to mix thoroughly, and proceed to Section 12.2 for extraction.
- 11.5** Preparation of samples containing greater than one percent solids.
- 11.5.1** Weigh a well-mixed aliquot of each sample (of the same matrix type) sufficient to provide 10 g of dry solids (based on the solids determination in Section 11.2) into a clean beaker or glass jar, to a maximum of 1 L of sample.
- 11.5.2** Spike 1.0 mL of the Labeled pesticide spiking solution (Section 7.12) into the sample.
- 11.5.3** Prepare the blank and OPR aliquots per Sections 11.4.2.3 - 11.4.2.5.
- 11.5.4** Stir or tumble and equilibrate the aliquots for 1 to 2 hours.
- 11.5.5** Decant excess water. If necessary to remove water, filter the sample through a glass-fiber filter and discard the aqueous liquid.
- 11.5.6** If particles >1 mm are present in the sample (as determined in Section 11.3.2), spread the sample on clean aluminum foil in a hood. After the sample is dry, grind to reduce the particle size (Section 11.7).
- 11.5.7** Extract the sample and QC aliquots using the SDS procedure in Section 12.3.1.
- 11.6** Multi-phase samples, including high solids municipal sludge samples
- 11.6.1** Using the percent solids determined in Section 11.2.1.4 or 11.2.2.3, determine the volume of sample that will provide 10 g of solids, up to 1 L of sample.
- 11.6.2** Spike 1.0 mL of the Labeled pesticide spiking solution (Section 7.12) into the amount of sample determined in Section 11.6.1, and into the OPR and blank.

- 11.6.3** Prepare the blank and OPR aliquots per Sections 11.4.2.3 - 11.4.2.5.
- 11.6.4** Pressure filter the sample, blank, and OPR through Whatman GF/D glass-fiber filter paper (Section 6.5.3). If necessary to separate the phases and/or settle the solids, centrifuge these aliquots prior to filtration. Discard any aqueous phase (if present). Remove any non-aqueous liquid present and reserve the maximum amount filtered from the sample (Section 11.5.5) or 10 g, whichever is less, for combination with the solid phase (Section 12.3.1.5).
- 11.6.5** If particles >1 mm are present in the sample (as determined in Section 11.3.2) and the sample is capable of being dried, spread the sample and QC aliquots on clean aluminum foil in a hood. Observe the precaution in Section 5.3.1.
- 11.6.6** After the aliquots are dry or if the sample cannot be dried, reduce the particle size using the procedures in Section 11.7 and extract the reduced-size particles using the SDS procedure in Section 12.3. If particles >1 mm are not present, extract the particles and filter in the sample and QC aliquots directly using the SDS procedure in Section 12.3.
- 11.7** Sample grinding, homogenization, or blending – Samples with particle sizes greater than 1 mm (as determined in Section 11.3.2) are subjected to grinding, homogenization, or blending. The method of reducing particle size to less than 1 mm is matrix-dependent. In general, hard particles can be reduced by grinding with a mortar and pestle. Softer particles can be reduced by grinding in a Wiley mill or meat grinder, by homogenization, or in a blender.
- 11.7.1** Each size-reducing preparation procedure on each matrix must be verified by running the tests in Section 9.2 before the procedure is employed routinely.
- 11.7.2** The grinding, homogenization, or blending procedures must be carried out in a glove box or fume hood to prevent particles from contaminating the work environment.
- 11.7.3** Grinding – Certain papers and pulps, slurries, and amorphous solids can be ground in a Wiley mill or heavy duty meat grinder. In some cases, reducing the temperature of the sample to freezing or to dry ice or liquid nitrogen temperatures can aid in the grinding process. Grind the sample aliquots from Sections 11.5.7 or 11.6.6 in a clean grinder. Do not allow the sample temperature to exceed 50°C. Grind the blank and reference matrix aliquots using a clean grinder.
- 11.7.4** Homogenization or blending – Particles that are not ground effectively, or particles greater than 1 mm in size after grinding, can often be reduced in size by high speed homogenization or blending. Homogenize and/or blend the particles or filter from Sections 11.5.7 or 11.6.6 for the sample, blank, and OPR aliquots.
- 11.7.5** Extract the aliquots using the SDS procedure in Section 12.3.1.

11.8 Fish and other tissues – Prior to processing tissue samples, the laboratory must determine the exact tissue to be analyzed. Common requests for analysis of fish tissue include whole fish-skin on, whole fish-skin removed, edible fish fillets (filleted in the field or by the laboratory), specific organs, and other portions. Once the appropriate tissue has been determined, the sample must be homogenized.

11.8.1 Tissue homogenization

11.8.1.1 Samples are homogenized while still frozen, where practical. If the laboratory must dissect the whole fish to obtain the appropriate tissue for analysis, the unused tissues may be rapidly refrozen and stored in a clean glass jar for subsequent use.

11.8.1.2 Each analysis requires 10 g of tissue (wet weight). Therefore, the laboratory should homogenize at least 20 g of tissue to allow for re-extraction of a second aliquot of the same homogenized sample, if re-analysis is required. When whole fish analysis is necessary, the entire fish is homogenized.

11.8.1.3 Homogenize the sample in a tissue homogenizer (Section 6.3.3) or grind in a meat grinder (Section 6.3.4). Cut tissue too large to feed into the grinder into smaller pieces. To assure homogeneity, grind three times.

11.8.1.4 Transfer approximately 10 g (wet weight) of homogenized tissue to a clean, tared, 400- to 500-mL beaker.

11.8.1.5 Transfer the remaining homogenized tissue to a clean jar with a fluoropolymer-lined lid. Seal the jar and store the tissue at less than -10°C . Return any tissue that was not homogenized to its original container and store at less than -10°C .

11.8.2 Tissue QC aliquots

11.8.2.1 Prepare a Method blank by adding approximately 1-2 g of the oily liquid reference matrix (Section 7.6.4) to a 400- to 500-mL beaker. Record the weight to the nearest 10 mg.

11.8.2.2 Prepare an ongoing precision and recovery aliquot by adding 1-2 g of the oily liquid reference matrix (Section 7.6.4) to a separate 400- to 500-mL beaker. Record the weight to the nearest 10 mg.

11.8.3 Spiking

11.8.3.1 Spike 1.0 mL of the Labeled pesticide spiking solution (Section 7.12) into the sample, blank, and OPR aliquot.

11.8.3.2 Spike 1.0 mL of the Native spiking solution (Section 7.11) into the OPR aliquot.

11.8.4 Extract the aliquots using the Soxhlet procedure in Section 12.4.

12.0 Extraction and concentration

12.1 Extraction procedures include: solid phase (Section 12.2.1), separatory funnel (Section 12.2.2), or continuous liquid/liquid (Section 12.2.3) for aqueous liquids; Soxhlet/Dean-Stark (Section 12.3.1) for sludge, solids and filters; and Soxhlet extraction (Section 12.4) for tissues.

Macro-concentration procedures include: rotary evaporation (Section 12.6.1), heating mantle (Section 12.6.2), and Kuderna-Danish (K-D) evaporation (Section 12.6.3). Micro-concentration uses nitrogen evaporation (Section 12.7).

12.2 Extraction of aqueous liquids – separatory or continuous liquid/liquid extraction.

12.2.1 Solid-phase extraction of samples containing less than one percent solids

12.2.1.1 Disk preparation

12.2.1.1.1 Remove the test tube from the suction flask (Figure 4). Place an SPE disk on the base of the filter holder and wet with methylene chloride. While holding a GMF 150 filter above the SPE disk with tweezers, wet the filter with methylene chloride and lay the filter on the SPE disk, making sure that air is not trapped between the filter and disk. Clamp the filter and SPE disk between the 1-L glass reservoir and the vacuum filtration flask.

12.2.1.1.2 Rinse the sides of the reservoir with approx 15 mL of methylene chloride using a squeeze bottle or pipet. Apply vacuum momentarily until a few drops appear at the drip tip. Release the vacuum and allow the filter/disk to soak for approx one minute. Apply vacuum and draw all of the methylene chloride through the filter/disk. Repeat the wash step with approx 15 mL of acetone and allow the filter/disk to air dry.

12.2.1.2 Sample extraction

12.2.1.2.1 Pre-wet the disk by adding approx 20 mL of methanol to the reservoir. Pull most of the methanol through the filter/disk, retaining a layer of methanol approx 2 mm

thick on the filter. Do not allow the filter/disk to go dry from this point until the extraction is completed.

- 12.2.1.2.2** Add approx 20 mL of reagent water to the reservoir and pull most through, leaving a layer approx 2 mm thick on the filter/disk.
- 12.2.1.2.3** Allow the sample (Section 11.4.2.6) to stand for 1-2 hours, if necessary, to settle the suspended particles. Decant the clear layer of the sample, the blank (Section 11.4.2.4), or IPR/OPR aliquot (Section 11.4.2.5) into its respective reservoir and turn on the vacuum to begin the extraction. Adjust the vacuum to complete the extraction in no less than 10 minutes. For samples containing a high concentration of particles (suspended solids), the extraction time may be an hour or longer.
- 12.2.1.2.4** Before all of the sample has been pulled through the filter/disk, add approx 50 mL of reagent water to the sample bottle, swirl to suspend the solids (if present), and pour into the reservoir. Pull through the filter/disk. Use additional reagent water rinses until all solids are removed.
- 12.2.1.2.5** Before all of the sample and rinses have been pulled through the filter/disk, rinse the sides of the reservoir with small portions of reagent water.
- 12.2.1.2.6** Partially dry the filter/disk under vacuum for approx 3 minutes.

12.2.1.3 Elution of the filter/disk

- 12.2.1.3.1** Release the vacuum, remove the entire filter/disk/reservoir assembly from the vacuum flask, and empty the flask. Insert a test tube for eluant collection into the flask. The test tube should have sufficient capacity to contain the total volume of the elution solvent (approx 50 mL) and should fit around the drip tip. The drip tip should protrude into the test tube to preclude loss of sample from spattering when vacuum is applied (see Figure 4). Re-assemble the filter/disk/reservoir assembly on the vacuum flask.
- 12.2.1.3.2** Wet the filter/disk with 4-5 mL of acetone. Allow the acetone to spread evenly across the disk and soak for 15-20 seconds. Pull the acetone through the disk, releasing the vacuum when approx 1 mm thickness remains on the filter.
- 12.2.1.3.3** Rinse the sample bottle with approx 20 mL of methylene chloride and transfer to the reservoir. Pull approx half of the solvent through the filter/disk and release the vacuum. Allow the filter/disk to soak for approx 1 minute. Pull all of the solvent through the disk. Repeat the bottle rinsing and elution step with another 20 mL of methylene chloride. Pull all of the solvent through the disk.
- 12.2.1.3.4** Release the vacuum, remove the filter/disk/reservoir assembly, and remove the test tube containing the sample solution. Quantitatively transfer the solution to a 250-mL separatory funnel and proceed to Section 12.5 for back-extraction.

12.2.2 Separatory funnel extraction

- 12.2.2.1** Pour the spiked sample (Section 11.4.2.2) into a 2-L separatory funnel. Rinse the bottle or flask twice with 5 mL of reagent water and add these rinses to the separatory funnel.
- 12.2.2.2** Add 100 mL methylene chloride to the empty sample bottle. Cap the bottle and shake 60 seconds to rinse the inner surface. Transfer the solvent to the separatory funnel, and extract the sample by shaking the funnel for 2 minutes with periodic venting. Allow the organic layer to separate from the aqueous phase for a minimum of 10 minutes. If an emulsion forms and is more than one-third the volume of the solvent layer, employ mechanical techniques to complete the phase separation

(see note below). Drain the methylene chloride extract through a solvent-rinsed glass funnel and dry over anhydrous sodium sulfate (Section 7.2.1) into an Erlenmeyer flask (1 L).

Note: *If an emulsion forms, the laboratory must employ mechanical techniques to complete the phase separation. The optimum technique depends upon the sample, but may include stirring, filtration through glass wool, use of phase separation paper, centrifugation, use of an ultrasonic bath with ice, addition of NaCl, or other physical methods. Alternatively, solid-phase (Section 12.2.1), CLLE (Section 12.2.3), or other extraction techniques may be used to prevent emulsion formation. Any alternative technique is acceptable so long as the requirements in Section 9.2 are met.*

12.2.2.3 Extract the water sample two more times with 100-mL portions of methylene chloride. Dry each portion over anhydrous sodium sulfate. After the third extraction, rinse the separatory funnel with at least 20 mL of methylene chloride, and add to the three 100-mL portions of methylene chloride. Repeat this rinse at least twice. Allow the methylene chloride extract to dry for 30 min. Transfer to a solvent-rinsed concentration device (Section 12.6).

12.2.2.4 Add 1 mL of a toluene "keeper" to the extract and concentrate using one of the macro-concentration procedures in Section 12.6, then proceed to back extraction in Section 12.5.

12.2.3 Continuous liquid/liquid extraction

12.2.3.1 Place 100-150 mL methylene chloride in each continuous extractor and 200-300 mL in each distilling flask.

12.2.3.2 Pour the sample(s), blank, and QC aliquots into the extractors. Rinse the sample containers with 50-100 mL methylene chloride and add to the respective extractors. Include all solids in the extraction process.

12.2.3.3 Begin the extraction by heating the flask until the methylene chloride is boiling. When properly adjusted, 1-2 drops of methylene chloride per second will fall from the condenser tip into the water. Extract for 16-24 hours.

12.2.3.4 Remove the distilling flask, estimate and record the volume of extract (to the nearest 100 mL), and pour the contents through a drying column containing 7 to 10 cm of granular anhydrous sodium sulfate into the concentration flask. Rinse the distilling flask with 30-50 mL of methylene chloride and pour through the drying column.

12.2.3.5 Add 1 mL of a toluene "keeper" to the extract and concentrate using one of the macro-concentration procedures in Section 12.6, then proceed to back extraction in Section 12.5.

12.3 Extraction of solids – Solid or sludge samples are extracted using a Soxhlet/Dean-Stark extractor (Section 12.3.1).

12.3.1 Soxhlet/Dean-Stark extraction

- 12.3.1.1** Charge a clean extraction thimble (Section 6.4.2.2) with 5.0 g of 100/200 mesh silica (Section 7.5.1.1) topped with 100 g of quartz sand (Section 7.3.2). Do not disturb the silica layer throughout the extraction process.
- 12.3.1.2** Place the thimble in a clean extractor. Place 30 to 40 mL of toluene in the receiver and 200 to 250 mL of toluene in the flask.
- 12.3.1.3** Pre-extract the glassware by heating the flask until the toluene is boiling. When properly adjusted, 1 to 2 drops of toluene will fall per second from the condenser tip into the receiver. Extract the apparatus for a minimum of 3 hours.
- 12.3.1.4** After pre-extraction, cool and disassemble the apparatus. Rinse the thimble with toluene and allow to air dry.
- 12.3.1.5** Load the wet sample and/or filter from Sections 11.5.7, 11.6.6, or 11.7.5 and any non-aqueous liquid from Section 11.6.4 into the thimble and manually mix into the sand layer with a clean metal spatula, carefully breaking up any large lumps of sample.
- 12.3.1.6** Reassemble the pre-extracted SDS apparatus, and add a fresh charge of 300 mL 80:20 toluene:acetone to the receiver and reflux flask. Apply power to the heating mantle to begin re-fluxing. Adjust the reflux rate to match the rate of percolation through the sand and silica beds until water removal lessens the restriction to toluene flow. Frequently check the apparatus for foaming during the first 2 hours of extraction. If foaming occurs, reduce the reflux rate until foaming subsides. Soxhlet extract for 12-24 hours.
- 12.3.1.7** Drain the water from the receiver at 1-2 hours and 8-9 hours, or sooner if the receiver fills with water. After 12-24 hours cool and disassemble the apparatus. Record the total volume of water collected.
- 12.3.1.8** Remove the distilling flask. Drain the water from the receiver and add any toluene in the receiver to the extract in the flask.
- 12.3.1.9** Concentrate the extracts from particles to approximately 10 mL using the rotary evaporator (Section 12.6.1) or heating mantle (Section 12.6.2), transfer to a 250-mL separatory funnel, and proceed with back-extraction (Section 12.5).

12.4 Soxhlet extraction of tissue

Note: *This procedure includes determination of the lipid content of the sample (Section 12.4.9), using the same sample extract that is analyzed by GC/HRMS. Alternatively, a separate sample aliquot may be used for the lipid determination. If a separate aliquot is used for GC/HRMS determination, use nitrogen to evaporate the main portion of the sample extract only to the extent necessary to effect the solvent exchange to n-hexane, so that loss of low molecular weight pesticides is avoided, i.e., it is not necessary to dry the main portion of the sample to constant weight (Section 12.4.8).*

- 12.4.1** Add 30 to 40 g of powdered anhydrous sodium sulfate (Section 7.2.2) to each of the beakers (Section 11.8.4) and mix thoroughly. Cover the beakers with aluminum foil and dry until the mixture becomes a free-flowing powder (30 minutes minimum). Remix prior to extraction to prevent clumping.
- 12.4.2** Assemble and pre-extract the Soxhlet apparatus per Sections 12.3.1-12.3.1.4, except use methylene chloride for the pre-extraction and rinsing and omit the quartz sand.
- 12.4.3** Re-assemble the pre-extracted Soxhlet apparatus and add a fresh charge of methylene chloride to the reflux flask.
- 12.4.4** Transfer the sample/sodium sulfate mixture (Section 12.4.1) to the Soxhlet thimble, and install the thimble in the Soxhlet apparatus.
- 12.4.5** Rinse the beaker with several portions of solvent and add to the thimble. Fill the thimble/receiver with solvent. Extract for 18-24 hours.
- 12.4.6** After extraction, cool and disassemble the apparatus.
- 12.4.7** Quantitatively transfer the extract to a macro-concentration device (Section 12.6) and concentrate to near dryness. Set aside the concentration apparatus for re-use.
- 12.4.8** Complete the removal of the solvent using the nitrogen blowdown procedure (Section 12.7) and a water bath temperature of 60°C. Weigh the receiver, record the weight, and return the receiver to the blowdown apparatus, concentrating the residue until a constant weight is obtained.
- 12.4.9** Percent lipid determination
- 12.4.9.1** Re-dissolve the residue in the receiver in hexane.
- 12.4.9.2** Transfer the residue/hexane to the anthropogenic isolation column (Section 13.6); retaining the boiling chips in the concentration apparatus. Use several rinses to assure that all material is transferred. If necessary, sonicate or heat the receiver slightly to assure that all

material is re-dissolved. Allow the receiver to dry. Weigh the receiver and boiling chips.

- 12.4.9.3** Calculate the lipid content to the nearest three significant figures as follows:

$$\text{Percent lipid} = \frac{\text{Weight of residue (g)}}{\text{Weight of tissue (g)}} \times 100$$

- 12.4.9.4** The laboratory should determine the lipid content of the blank, IPR, and OPR to assure that the extraction system is working effectively.

12.5 Back-extraction with base and acid

Note: *Some pesticides may be decomposed by acid or base. If acid or base back-extraction is employed, the laboratory must evaluate the strengths of the acid and base solutions, and the exposure times, to preclude decomposition.*

- 12.5.1** Back-extraction may not be necessary for some samples, and back-extraction with strong acid and/or base with long contact times may destroy some pesticides. For some samples, the presence of color in the extract may indicate that back-extraction is necessary. If back-extraction is not necessary, concentrate the extract for cleanup or analysis (Section 12.6 and/or 12.7). If back-extraction is necessary, back-extract the extracts from Section 12.2.3.5 or 12.3.1.9 as follows:

- 12.5.2** Back-extract each extract three times sequentially with 500 mL of the aqueous sodium sulfate solution (Section 7.1.5), returning the bottom (organic) layer to the separatory funnel the first two times while discarding the top (aqueous) layer. On the final back-extraction, filter each pesticide extract through a prerinsed drying column containing 7 to 10 cm anhydrous sodium sulfate into a 500- to 1000-mL graduated cylinder. Record the final extract volume. Re-concentrate the sample and QC aliquots per Sections 12.6-12.7, and clean up the samples and QC aliquots per Section 13.

- 12.6** Macro-concentration – Extracts in toluene are concentrated using a rotary evaporator or a heating mantle; extracts in methylene chloride or hexane are concentrated using a rotary evaporator, heating mantle, or Kuderna-Danish apparatus.

Note: *In the concentration procedures below, the extract must not be allowed to concentrate to dryness because low molecular weight pesticides may be totally or partially lost. It may be advantageous to add 1 mL of toluene as a "keeper" to prevent loss of the low molecular weight pesticides.*

- 12.6.1** Rotary evaporation – Concentrate the extracts in separate round-bottom flasks.

- 12.6.1.1** Assemble the rotary evaporator according to manufacturer's instructions, and warm the water bath to 45°C. On a daily basis, pre-

clean the rotary evaporator by concentrating 100 mL of clean extraction solvent through the system. Archive both the concentrated solvent and the solvent in the catch flask for a contamination check if necessary. Between samples, three 2- to 3- mL aliquots of solvent should be rinsed down the feed tube into a waste beaker.

- 12.6.1.2** Attach the round-bottom flask containing the sample extract to the rotary evaporator. Slowly apply vacuum to the system, and begin rotating the sample flask.
- 12.6.1.3** Lower the flask into the water bath, and adjust the speed of rotation and the temperature as required to complete concentration in 15 to 20 minutes. At the proper rate of concentration, the flow of solvent into the receiving flask will be steady, but no bumping or visible boiling of the extract will occur.

Note: *If the rate of concentration is too fast, analyte loss may occur.*

- 12.6.1.4** When the liquid in the concentration flask has reached an apparent volume of approximately 2 mL, remove the flask from the water bath and stop the rotation. Slowly and carefully admit air into the system. Be sure not to open the valve so quickly that the sample is blown out of the flask. Rinse the feed tube with approximately 2 mL of solvent.
 - 12.6.1.5** Proceed to Section 12.5 for back-extraction or Section 12.7 for micro-concentration and solvent exchange.
- 12.6.2** Heating mantle – Concentrate the extracts in separate round-bottom flasks.
- 12.6.2.1** Add one or two clean boiling chips to the round-bottom flask, and attach a three-ball macro Snyder column. Prewet the column by adding approximately 1 mL of solvent through the top. Place the round-bottom flask in a heating mantle, and apply heat as required to complete the concentration in 15 to 20 minutes. At the proper rate of distillation, the balls of the column will actively chatter, but the chambers will not flood.
 - 12.6.2.2** When the liquid has reached an apparent volume of approximately 10 mL, remove the round-bottom flask from the heating mantle and allow the solvent to drain and cool for at least 10 minutes. Remove the Snyder column and rinse the glass joint into the receiver with small portions of solvent.
 - 12.6.2.3** Proceed to Section 12.6 for preparation for back-extraction or Section 12.7 for micro-concentration and solvent exchange.

- 12.6.3** Kuderna-Danish (K-D) – Concentrate the extracts in separate 500-mL K-D flasks equipped with 10-mL concentrator tubes. The K-D technique is used for solvents such as methylene chloride and hexane. Toluene is difficult to concentrate using the K-D technique unless a water bath fed by a steam generator is used.
- 12.6.3.1** Add 1 to 2 clean boiling chips to the receiver. Attach a three-ball macro Snyder column. Prewet the column by adding approximately 1 mL of solvent through the top. Place the K-D apparatus in a hot water bath so that the entire lower rounded surface of the flask is bathed with steam.
- 12.6.3.2** Adjust the vertical position of the apparatus and the water temperature as required to complete the concentration in 15 to 20 minutes. At the proper rate of distillation, the balls of the column will actively chatter but the chambers will not flood.
- 12.6.3.3** When the liquid has reached an apparent volume of 1 mL, remove the K-D apparatus from the bath and allow the solvent to drain and cool for at least 10 minutes. Remove the Snyder column and rinse the flask and its lower joint into the concentrator tube with 1 to 2 mL of solvent. A 5-mL syringe is recommended for this operation.
- 12.6.3.4** Remove the three-ball Snyder column, add a fresh boiling chip, and attach a two ball micro Snyder column to the concentrator tube. Prewet the column by adding approximately 0.5 mL of solvent through the top. Place the apparatus in the hot water bath.
- 12.6.3.5** Adjust the vertical position and the water temperature as required to complete the concentration in 5 to 10 minutes. At the proper rate of distillation, the balls of the column will actively chatter but the chambers will not flood.
- 12.6.3.6** When the liquid reaches an apparent volume of 0.5 mL, remove the apparatus from the water bath and allow to drain and cool for at least 10 minutes.
- 12.6.3.7** Proceed to 12.6 for preparation for back-extraction or Section 12.7 for micro-concentration and solvent exchange.

12.7 Micro-concentration and solvent exchange

- 12.7.1** Extracts to be subjected to GPC cleanup are exchanged into methylene chloride. Extracts to be cleaned up using silica gel, Florisil, the SPE cartridge, and/or HPLC are exchanged into hexane.
- 12.7.2** Transfer the vial containing the sample extract to a nitrogen evaporation device. Adjust the flow of nitrogen so that the surface of the solvent is just visibly disturbed.

Note: *A large vortex in the solvent may cause analyte loss.*

- 12.7.3** Lower the vial into a 30°C water bath and continue concentrating.
- 12.7.3.1** If the extract or an aliquot of the extract is to be concentrated to dryness for weight determination (Sections 12.4.8 and 13.6.4), blow dry until a constant weight is obtained.
- 12.7.3.2** If the extract is to be concentrated for injection into the GC/HRMS or the solvent is to be exchanged for extract cleanup, proceed as follows:
- 12.7.4** When the volume of the liquid is approximately 100 µL, add 2 to 3 mL of the desired solvent (methylene chloride for GPC and HPLC, or hexane for the other cleanups) and continue concentration to approximately 100 µL. Repeat the addition of solvent and concentrate once more.
- 12.7.5** If the extract is to be cleaned up by GPC, adjust the volume of the extract to 5.0 mL with methylene chloride. If the extract is to be cleaned up by HPLC, concentrate the extract to 1.0 mL. Proceed with GPC or HPLC cleanup (Section 13.2 or 13.5, respectively).
- 12.7.6** If the extract is to be cleaned up by column chromatography or the SPE cartridge, bring the final volume to 1.0 mL with hexane. Proceed with column cleanup (Sections 13.3, 13.4, 13.7, or 13.8).
- 12.7.7** If the extract is to be concentrated for injection into the GC/HRMS (Section 14), quantitatively transfer the extract to a 0.3-mL conical vial for final concentration, rinsing the larger vial with hexane and adding the rinse to the conical vial. Reduce the volume to approximately 100 µL. Add 20 µL of nonane to the vial, and evaporate the solvent to the level of the nonane. Seal the vial and label with the sample number. Store in the dark at room temperature until ready for GC/HRMS analysis. If GC/HRMS analysis will not be performed on the same day, store the vial at less than -10°C.

13.0 Extract cleanup

- 13.1** Cleanup may not be necessary for relatively clean samples (e.g., treated effluents, groundwater, drinking water). If particular circumstances require the use of a cleanup procedure, the laboratory may use any or all of the procedures below or any other appropriate procedure. Before using a cleanup procedure, the laboratory must demonstrate that the requirements of Section 9.2 can be met using the cleanup procedure. The following table suggests cleanups that may be used for the various analyte groups.

Analyte group	Suggested cleanups
All	GPC (13.2); SPE (13.3); Micro-silica (13.4)

Organo-chlorine	GPC, SPE, Micro-silica plus Florisil (13.7) or alumina (13.8)
Specific compounds	GPC, SPE, Micro-silica plus HPLC (13.5)

13.1.1 Gel permeation chromatography (Section 13.2) removes high molecular weight interferences that cause GC column performance to degrade. It should be used for all soil and sediment extracts. It may be used for water extracts that are expected to contain high molecular weight organic compounds (e.g., polymeric materials, humic acids). It should also be used for tissue extracts after initial cleanup on the anthropogenic isolation column (Section 13.6).

13.1.2 Micro-silica (Section 13.4), the SPE cartridge (Section 13.3), Florisil (Section 13.7), and alumina (Section 13.8) may be used to remove non-polar and polar interferences.

13.1.3 HPLC (Section 13.5) is used to provide specificity for certain pesticides.

13.1.4 The anthropogenic isolation column (Section 13.6) is used for removal of lipids from tissue samples.

13.2 Gel permeation chromatography (GPC)

13.2.1 Column packing

13.2.1.1 Place 70 to 75 g of SX-3 Bio-beads (Section 6.7.1.1) in a 400- to 500-mL beaker.

13.2.1.2 Cover the beads with methylene chloride and allow to swell overnight (a minimum of 12 hours).

13.2.1.3 Transfer the swelled beads to the column (Section 6.7.1.1) and pump solvent through the column, from bottom to top, at 4.5 to 5.5 mL/minute prior to connecting the column to the detector.

13.2.1.4 After purging the column with solvent for 1 to 2 hours, adjust the column head pressure to 7 to 10 psig and purge for 4 to 5 hours to remove air. Maintain a head pressure of 7 to 10 psig. Connect the column to the detector (Section 6.7.1.4).

13.2.2 Column calibration

13.2.2.1 Load 5 mL of the GPC calibration solution (Section 7.4) into the sample loop.

13.2.2.2 Inject the GPC calibration solution and record the signal from the detector. The elution pattern will be corn oil, bis(2-ethylhexyl) phthalate (BEHP), methoxychlor, perylene, and sulfur.

- 13.2.2.3** Set the "dump time" to allow >85% removal of BEHP and >85% collection of methoxychlor.
- 13.2.2.4** Set the "collect time" to the time of the sulfur peak maximum.
- 13.2.2.5** Verify calibration with the GPC calibration solution after every 20 extracts. Calibration is verified if the recovery of methoxychlor is greater than 85%. If calibration is not verified, the system must be recalibrated using the GPC calibration solution, and the previous sample batch must be re-extracted and cleaned up using a calibrated GPC system.

13.2.3 Extract cleanup – GPC requires that the column not be overloaded. The column specified in this Method is designed to handle a maximum of 0.5 g of material from an aqueous, soil, or mixed-phase sample in a 5-mL extract, and has been shown to handle 1.5 g of lipid from a tissue sample in a 5-mL extract. If the extract is known or expected to contain more than these amounts, the extract is split into aliquots for GPC, and the aliquots are combined after elution from the column. The residue content of the extract may be obtained gravimetrically by evaporating the solvent from a 50- μ L aliquot.

- 13.2.3.1** Filter the extract or load through the filter holder (Section 6.7.1.3) to remove particles. Load the 5.0-mL extract onto the column.
- 13.2.3.2** Elute the extract using the calibration data determined in Section 13.2.2. Collect the eluate in a clean 400- to 500-mL beaker. Allow the system to rinse for additional 10 minutes before injecting the next sample.
- 13.2.3.3** Rinse the sample loading tube thoroughly with methylene chloride between extracts to prepare for the next sample.
- 13.2.3.4** If an extract is encountered that could overload the GPC column to the extent that carry-over could occur, a 5.0-mL methylene chloride blank must be run through the system to check for carry-over.
- 13.2.3.5** Concentrate the eluate per Sections 12.6 and 12.7 for further cleanup or injection into the GC/MS.

13.3 Solid-phase extraction (SPE) cartridge

13.3.1 Setup

- 13.3.1.1** Attach the Vac-elute manifold (6.7.6.1) to a water aspirator or vacuum pump with the trap and gauge installed between the manifold and vacuum source.

- 13.3.1.2** Place the SPE cartridge(s) in the manifold, turn on the vacuum source, and adjust the vacuum to 5 to 10 psig.

Note: Do not allow the SPE cartridge to go dry during the following steps.

- 13.3.2** Cartridge washing – Pre-elute the cartridge sequentially with two 6-mL volumes of 1:2:1 ethyl acetate:acetonitrile:toluene.
- 13.3.3** Using a pipette or a 1-mL syringe, transfer 1.0 mL of the extract in 1:2:1 ethyl acetate:acetonitrile:toluene (Section 12.2.3.5, 12.3.1.9, 12.4.8 or 12.5.2) onto the SPE cartridge followed by a rinse of 1 mL 1:2:1 ethyl acetate:acetonitrile:toluene.
- 13.3.4** As soon as the sample is loaded, begin to collect the eluate in a round bottom flask or centrifuge tube (if using a manifold). Elute the SPE cartridge with 11 mL of 1:2:1 ethyl acetate:acetonitrile:toluene.
- 13.3.5** Concentrate the eluted extract per Sections 12.6 and 12.7 and proceed to other cleanups or determination by HRGC/HRMS.

13.4 Micro-silica column

- 13.4.1** Place a small glass-wool plug in a clean Pasteur pipette. Rinse the pipette and glass wool twice with small (e.g., 2 - 5 mL) volumes of toluene, followed by two rinsings with small volumes of hexane. Allow the pipette to drain. Dry pack the column bottom to top with 0.75 gram of 10% deactivated silica (Section 7.5.1.1). Tap the column to settle the silica.
- 13.4.2** Rinse the column with hexane until the column is completely wetted (typically 5-10 mL). Allow the hexane to drain to the top of the silica.
- 13.4.3** Adjust the extract volume to 1.0 mL and apply to the column. Allow the extract to drain to the top of the silica. Rinse the extract onto the column with 500 μ L of hexane.
- 13.4.4** Rinse the centrifuge tube that contained the extract with 300- μ L of 10% methanol in dichloromethane and apply to the column. Collect the eluate in a round-bottom flask. Repeat this rinse and collect the eluate in the flask.
- 13.4.5** Elute the column with 5 mL of 10% methanol in dichloromethane. Collect the eluate in the round bottom flask.
- 13.4.6** Add 5 mL of acetone and 1 mL of iso-octane to the round bottom flask and concentrate the eluate per Section 12.6 and 12.7 for further cleanup or injection into the HPLC or GC/MS.

- 13.4.7** For extracts of samples known to contain large quantities of other organic compounds, it may be advisable to increase the capacity of the silica gel column. This may be accomplished by increasing the strength of the acid silica and including basic silica gel. The acid silica gel (Section 7.5.1.2) may be increased in strength to as much as 40% w/w (6.7 g sulfuric acid added to 10 g silica gel). The basic silica gel (Section 7.5.1.3) may be increased in strength to as much as 33% w/w (50 mL 1N NaOH added to 100 g silica gel), or the potassium silicate (Section 7.5.1.4) may be used. Larger columns may also be used if needed.

Note: *The use of stronger acid and basic silica gel (44% w/w) may lead to charring of organic compounds in some extracts. The charred material may retain some of the analytes and lead to lower recoveries of the pesticides. Increasing the strengths of the acid and basic silica gel may also require different volumes of eluants than those specified above to elute the analytes from the column. The performance of the Method after such modifications must be verified by the procedure in Section 9.2.*

13.5 HPLC (Reference 9)

13.5.1 Column calibration

- 13.5.1.1** Prepare a calibration standard containing the pesticides at the concentrations of the stock solution in Table 3, or at a concentration appropriate to the response of the detector.
- 13.5.1.2** Inject the calibration standard into the HPLC and record the signal from the detector. Collect the eluant for reuse.
- 13.5.1.3** Establish the collection time for the pesticides of interest. Following calibration, flush the injection system with solvent to ensure that residual pesticides are removed from the system.
- 13.5.1.4** Verify the calibration with the calibration solution after every 20 extracts. Calibration is verified if the recovery of the pesticides is 75 to 125% compared to the calibration (Section 13.5.1.1). If calibration is not verified, the system must be recalibrated using the calibration solution, and the batch of samples run on the uncalibrated system must be re-extracted and cleaned up using a calibrated system.

- 13.5.2** Extract cleanup – HPLC requires that the column not be overloaded. The column specified in this Method is designed to handle a maximum of 50 μ g of a given pesticide, depending on the particular compound. If the amount of material in the extract will overload the column, split the extract into fractions and combine the fractions after elution from the column.

- 13.5.2.1** Rinse the sides of the vial containing the sample and adjust to the volume required for the sample loop for injection.
- 13.5.2.2** Inject the sample extract into the HPLC.

13.5.2.3 Elute the extract using the calibration data determined in Section 13.5.1. Collect the fraction(s) in clean 20-mL concentrator tubes.

13.5.2.4 If an extract containing greater than 500 µg of total material is encountered, a blank must be run through the system to check for carry-over.

13.5.2.5 Concentrate the eluate per Section 12.7 for injection into the

GC/HRMS.

13.6 Anthropogenic isolation column (Reference 15) – Used for removal of lipids from tissue extracts

13.6.1 Prepare the column as given in Section 7.5.2.

13.6.2 Pre-elute the column with 100 mL of hexane. Drain the hexane layer to the top of the column, but do not expose the sodium sulfate.

13.6.3 Load the sample and rinses (Section 12.4.9.2) onto the column by draining each portion to the top of the bed. Elute the pesticides from the column into the apparatus used for concentration (Section 12.4.7) using 200 mL of hexane.

13.6.4 Remove a small portion (e.g., 50 µL) of the extract for determination of residue content. Estimate the percent of the total that this portion represents. Concentrate the small portion to constant weight per Section 12.7.3.1. Calculate the total amount of residue in the extract. If more than 500 mg of material remains, repeat the cleanup using a fresh anthropogenic isolation column.

13.6.5 If necessary, exchange the extract to a solvent suitable for the additional cleanups to be used (Section 13.2 - 13.8).

13.6.6 Clean up the extract using the procedures in Sections 13.2 - 13.8. GPC (Section 13.2) and Florisil (Section 13.7) are recommended as minimum additional cleanup steps.

13.6.7 Following cleanup, concentrate the extract to 20 ΦL per Section 12.7 and proceed with the analysis in Section 14.

13.7 Florisil

13.7.1 Begin to drain the n-hexane from the column (Section 7.5.4.3). Adjust the flow rate of eluant to 4.5 - 5.0 mL/min.

13.7.2 When the n-hexane is within 1 mm of the sodium sulfate, apply the sample extract (in hexane) to the column. Rinse the sample container twice with 1-mL portions of hexane and apply to the column, allowing the hexane to drain to the top of the sodium sulfate layer.

13.7.3 Elute Fraction 1 with 200 mL of 6% ethyl ether in n-hexane and collect the eluate. Elute Fraction 2 with 200 mL of 15% ethyl ether in hexane and collect the eluate. Elute Fraction 3 with 50% ethyl ether in hexane and collect the eluate. The exact volumes of solvents will need to be determined for each batch of Florisil. If the pesticides are not to be collected in separate fractions, elute all pesticides with 50% ethyl ether in hexane.

13.7.4 Concentrate the eluate(s) per Sections 12.6 - 12.7 for further cleanup or for injection into the HPLC or GC/HRMS.

13.8 Alumina

13.8.1 Begin to drain the hexane from the column (Section 7.5.5.2). Adjust the flow rate of eluant to 4.5 - 5.0 mL/min.

13.8.2 When the n-hexane is within 1 mm of the sodium sulfate, apply the sample extract (in hexane) to the column. Rinse the sample container twice with 1-mL portions of hexane and apply to the column, allowing the hexane to drain to the top of the sodium sulfate layer.

13.8.3 Elute the pesticides with 150 mL of n-hexane. If all pesticides are not eluted, elute the remaining pesticides with 50 mL of 15% methylene chloride in n-hexane.

13.8.4 Concentrate the eluate(s) per Sections 12.6 - 12.7 for further cleanup or for injection into the HPLC or GC/HRMS.

14.0 HRGC/HRMS analysis

14.1 Establish the operating conditions given in Section 10.1.

14.2 Add 2 μL of the labeled injection internal standard spiking solution (Section 7.14) to the 20 μL sample extract immediately prior to injection to minimize the possibility of loss by evaporation, adsorption, or reaction. If an extract is to be reanalyzed and evaporation has occurred, do not add more labeled injection internal standard spiking solution. Rather, bring the extract back to its previous volume (e.g., 19 μL) with pure nonane (18 μL if 2 μL injections are used).

14.3 Inject 1.0 or 2.0 μL of the concentrated extract containing the Labeled injection internal standards using on-column or splitless injection. The volume injected must be identical to the volume used for calibration (Section 10.3).

14.3.1 Start the GC column initial isothermal hold upon injection. Start MS data collection after the solvent peak elutes.

- 14.3.2** Monitor the exact m/z's for each pesticide throughout its retention time window. Where warranted, monitor m/z's associated with pesticides at higher levels of chlorination to assure that fragments are not interfering with the m/z's for pesticides at lower levels of chlorination. Also where warranted, monitor m/z's associated with interferents expected to be present.
- 14.3.3** Stop data collection after permethrin and cypermethrin have eluted. Return the column to the initial temperature for analysis of the next sample extract or standard.

15.0 System and laboratory performance

- 15.1** At the beginning of each 12-hour shift during which analyses are performed, GC/MS system performance and calibration are verified for all the pesticides and labeled compounds. For these tests, analysis of the CS-4 calibration verification (VER) standard (Section 7.10 and Table 4) must be used to verify all performance criteria. Adjustment and/or recalibration (Section 10) must be performed until all performance criteria are met. Only after all performance criteria are met may samples, blanks, IPRs, and OPRs be analyzed.
- 15.2** MS resolution – Static resolving power checks must be performed at the beginning and at the end of each shift per Sections 10.2.1. If analyses are performed on successive shifts, only the beginning of shift static resolving power check is required. If the requirement in Section 10.2.1 cannot be met, the problem must be corrected before analyses can proceed. If any of the samples in the previous shift may be affected by poor resolution, those samples must be re-analyzed.
- 15.3** Calibration verification
- 15.3.1** Inject the VER (CS-4) calibration standard using the procedure in Section 14.
- 15.3.2** The m/z abundance ratios for all pesticides must be within the limits in Table 6; otherwise, the mass spectrometer must be adjusted until the m/z abundance ratios fall within the limits specified when the verification test is repeated. If the adjustment alters the resolution of the mass spectrometer, resolution must be verified (Section 10.2.1) prior to repeat of the verification test.
- 15.3.3** The GC peak representing each native pesticide and labeled compound in the VER standard must be present with a S/N of at least 10; otherwise, the mass spectrometer must be adjusted and the verification test repeated.
- 15.3.4** Compute the concentration of the pesticides that have labeled analogs by isotope dilution and the concentration of the pesticides that do not have labeled analogs by the internal standard technique. These concentrations are computed based on the calibration data in Section 10.

15.3.5 For each compound, compare the concentration with the calibration verification limit in Table 5. If all compounds meet the acceptance criteria, calibration has been verified and analysis of standards and sample extracts may proceed. If, however, any compound fails its respective limit, the measurement system is not performing properly. In this event, prepare a fresh calibration standard or correct the problem and repeat the resolution (Section 15.2) and verification (Section 15.3) tests, or recalibrate (Section 10).

15.4 Retention times and GC resolution

15.4.1 Retention times.

15.4.1.1 Absolute – The absolute retention times of the Labeled compounds in the verification test (Section 15.3) must be within \forall 15 seconds of the respective retention times in the calibration (Section 10.1)

15.4.1.2 Relative – The relative retention times of native pesticides and the labeled compounds in the verification test (Section 15.3) must be within their respective RRT limits in Table 2 or, if an alternate column or column system is employed, within their respective RRT limits for the alternate column or column system (Sections 9.1.2.3 and 6.9.1).

15.4.1.3 If the absolute or relative retention time of any compound is not within the limits specified, the GC is not performing properly. In this event, adjust the GC and repeat the verification test (Section 15.3) or recalibrate (Section 10), or replace the GC column and either verify calibration or recalibrate.

15.4.2 GC resolution and minimum analysis time

15.4.2.1 The resolution and minimum analysis time specifications in Sections 6.9.1.1.2 and 6.9.1.1.1, respectively, must be met for the DB-17 column or, if an alternate column or column system is employed, must be met as specified for the alternate column or column system (Sections 9.1.2.3 and 6.9.1). If these specifications are not met, the GC analysis conditions must be adjusted until the specifications are met, or the column must be replaced and the calibration verification tests repeated (Sections 15.3 - 15.4), or the system must be recalibrated (Section 10).

15.4.2.2 After the resolution and minimum analysis time specifications are met, update the retention times and relative retention times, but not the relative responses and response factors. For the relative responses and response factors, the multi-point calibration data (Sections 10.4 and 10.5) must be used.

- 15.5** Endrin/4,4'-DDT breakdown – Perform the endrin/4,4'-DDT breakdown test (Section 10.6). The breakdown specification (Section 10.6.2.3) must be met before an OPR, sample, or blank may be analyzed.
- 15.6** Ongoing precision and recovery
- 15.6.1** Analyze the extract of the ongoing precision and recovery (OPR) aliquot (Section 11.4.2.5, 11.5.3, 11.6.3, or 11.8.3.2) prior to analysis of samples from the same batch.
- 15.6.2** Compute the percent recovery of the pesticides with labeled analogs by isotope dilution (Section 10.4). Compute the percent recovery of each labeled compound by the internal standard method (Section 10.5).
- 15.6.3** For the pesticides and labeled compounds, compare the recovery to the OPR limits given in Table 5. If all compounds meet the acceptance criteria, system performance is acceptable and analysis of blanks and samples may proceed. If, however, any individual concentration falls outside of the range given, the extraction/concentration processes are not being performed properly for that compound. In this event, correct the problem, re-prepare, extract, and clean up the sample batch and repeat the ongoing precision and recovery test (Section 15.6).
- 15.6.4** If desired, add results that pass the specifications in Section 15.6.3 to initial (Section 9.4) and previous ongoing data for each compound in each matrix. Update QC charts to form a graphic representation of continued laboratory performance. Develop a statement of laboratory accuracy for each pesticide in each matrix type by calculating the average percent recovery (R) and the standard deviation of percent recovery (S_R). Express the accuracy as a recovery interval from $R - 2S_R$ to $R + 2S_R$. For example, if $R = 95\%$ and $S_R = 5\%$, the accuracy is 85 to 105%.
- 15.7** Blank – Analyze the Method blank extracted with each sample batch immediately following analysis of the OPR aliquot to demonstrate freedom from contamination and freedom from carryover from the OPR analysis. If pesticides will be carried from the OPR into the Method blank, analyze one or more aliquots of solvent between the OPR and the Method blank. The results of the analysis of the blank must meet the specifications in Section 9.5.2 before sample analyses may proceed.

16.0 Qualitative determination

A pesticide or labeled compound is identified in a standard, blank, or sample when all of the criteria in Sections 16.1 through 16.4 are met.

- 16.1** The signals for the two exact m/z's in Table 6 must be present and must maximize within the same two scans.
- 16.2** The signal-to-noise ratio (S/N) for the GC peak at each exact m/z must be greater than or equal to 2.5 for each pesticide detected in a sample extract, and greater than or equal to 10 for all pesticides in the calibration and verification standards (Sections 10.3.3 and 15.6.3).
- 16.3** The ratio of the integrated areas of the two exact m/z's specified in Table 6 must be within the limit in Table 6, or within ∇ 15 percent of the ratio in the midpoint (CS-4) calibration or calibration verification (VER), whichever is most recent.
- 16.4** The relative retention time of the peak for a pesticide must be within the RRT QC limits specified in Table 2 or within similar limits developed from calibration data (Section 10.1.2). If an alternate column (Section 9.1.2.3) is employed, the RRT for the pesticide must be within its respective RRT QC limits for the alternate column or column system (Section 6.9.1).

Note: *For native pesticides determined by internal standard quantitation, a pesticide with the same exact m/z's as other pesticides may fall within more than one RT window and be mis-identified unless the RRT windows are made very narrow, as in Table 2. Therefore, consistency of the RT and RRT with other pesticides and the labeled compounds may be required for rigorous pesticide identification. Retention time regression may aid in this identification.*

- 16.5** Because of pesticide RT overlap and the potential for interfering substances, it is possible that all of the identification criteria (Sections 16.1 - 16.4) may not be met. It is also possible that loss of one or more chlorines from a highly chlorinated pesticide or interferent may inflate or produce a false concentration for a less-chlorinated pesticide that elutes at the same retention time (see Section 18). If identification is ambiguous, an experienced spectrometrist (Section 1.5) must determine the presence or absence of the pesticide.
- 16.6** If the criteria for identification in Sections 16.1 - 16.5 are not met, the pesticide has not been identified and the result for that pesticide may not be reported or used for permitting or regulatory compliance purposes. If interferences preclude identification, a new aliquot of sample must be extracted, further cleaned up, and analyzed.

17.0 Quantitative determination

17.1 Isotope dilution quantitation

- 17.1.1** By adding a known amount of the labeled pesticides to every sample prior to extraction, correction for recovery of each pesticide can be made because the native

compound and its labeled analog exhibit similar effects upon extraction, concentration, and gas chromatography. Relative responses (RRs) are used in conjunction with the calibration data in Section 10.4 to determine concentrations in the final extract, so long as labeled compound spiking levels are constant.

- 17.1.2** Compute the concentrations of the pesticides in the extract using the RRs from the calibration data (Section 10.4) and following equation:

$$C_{ex} \text{ (ng/mL)} = \frac{(A1_n + A2_n) C_l}{(A1_l + A2_l) RR}$$

Where:

C_{ex} = The concentration of the pesticide in the extract, and the other terms are as defined in Section 10.4.3

- 17.2** Internal standard quantitation and labeled compound recovery

- 17.2.1** Compute the concentrations in the extract of the native compounds that do not have labeled analogs using the response factors determined from the calibration data (Section 10.5) and the following equation:

$$C_{ex} \text{ (ng/mL)} = \frac{(A1_s + A2_s) C_{is}}{(A1_{is} + A2_{is}) RF}$$

Where:

C_{ex} = The concentration of the labeled compound in the extract, and the other terms are as defined in Section 10.5.1

- 17.2.2** Using the concentration in the extract determined above, compute the percent recovery of the labeled pesticides other labeled cleanup standard using the following equation:

$$\text{Recovery (\%)} = \frac{\text{Concentration found (ng/mL)}}{\text{Concentration spiked (ng/mL)}} \times 100$$

- 17.3** The concentration of a native compound in the solid phase of the sample is computed using the concentration of the compound in the extract and the weight of the solids (Section 11.2.2.3), as follows:

$$\text{Concentration in solid (ng/kg)} = \frac{(C_{ex} \times V_{ex})}{W_s}$$

Where:

C_{ex} = The concentration of the compound in the extract.
 V_{ex} = The extract volume in mL.
 W_s = The sample weight (dry weight) in kg.

- 17.4** The concentration of a native pesticide in the aqueous phase of the sample is computed using the concentration of the compound in the extract and the volume of water extracted (Section 11.4), as follows:

$$\text{Concentration in aqueous phase (pg/L)} = 1000 \times \frac{(C_{ex} \times V_{ex})}{V_s}$$

Where:

- C_{ex} = The concentration of the compound in the extract.
 V_{ex} = The extract volume in mL.
 V_s = The sample volume in liters.

- 17.5** If the SICP area at either quantitation m/z for any pesticide exceeds the calibration range of the system, dilute the sample extract by the factor necessary to bring the concentration within the calibration range, adjust the concentration of the Labeled injection internal standard to 100 pg/ μ L in the extract, and analyze an aliquot of this diluted extract. If the pesticides cannot be measured reliably by isotope dilution, dilute and analyze an aqueous sample or analyze a smaller portion of a soil, tissue, or mixed-phase sample. Adjust the pesticide concentrations, detection limits, and minimum levels to account for the dilution.

17.6 Reporting of results

17.6.1 Reporting units and levels

17.6.1.1 Aqueous samples – Report results in pg/L (parts-per-quadrillion).

17.6.1.2 Samples containing greater than 1% solids (soils, sediments, filter cake, compost) – Report results in ng/kg based on the dry weight of the sample. Report the percent solids so that the result may be converted to aqueous units.

17.6.1.3 Tissues – Report results in ng/kg of wet tissue, not on the basis of the lipid content of the tissue. Report the percent lipid content, so that the data user can calculate the concentration on a lipid basis if desired.

17.6.2 Reporting level

17.6.2.1 Report the result for each pesticide in each sample, blank, or standard (VER, IPR, OPR) at or above the minimum level of quantitation (ML; Table 1) to 3 significant figures. Report the result below the ML in each sample as <ML (where ML is the concentration at the ML) or as required by the regulatory authority or permit.

17.6.2.2 Blanks – Report the result for each pesticide below the ML but above the MDL to 2 significant figures. Report results below the MDL as <MDL (where MDL is the concentration at the MDL) or as required by the regulatory authority or permit. In addition to reporting results for

the samples and blank(s) separately, the concentration of each pesticide in a method blank or field blank associated with the sample may be subtracted from the results for that sample, or must be subtracted if requested or required by a regulatory authority or in a permit.

- 17.6.2.3** Results for a pesticide in a sample that has been diluted are reported at the least dilute level at which the area at the quantitation m/z is within the calibration range (Section 17.5).
- 17.6.2.4** For a pesticide having a labeled analog, report results at the least dilute level at which the area at the quantitation m/z is within the calibration range (Section 17.5) and the labeled compound recovery is within the normal range for the Method (Section 9.3 and Table 5).
- 17.6.2.5** Results from tests performed with an analytical system that is not in control must not be reported or otherwise used for permitting or regulatory compliance purposes, but do not relieve a discharger or permittee of reporting timely results.

18.0 Analysis of complex samples

- 18.1** Some samples may contain high levels (>10 ng/L; >1000 ng/kg) of the compounds of interest, interfering compounds, and/or polymeric materials. Some extracts may not concentrate to 20 μ L (Section 12.7); others may overload the GC column and/or mass spectrometer. A fragment ion from a pesticide at a higher level of chlorination may interfere with determination of a pesticide at a lower level of chlorination.
- 18.2** Analyze a smaller aliquot of the sample (Section 17.5) when the extract will not concentrate to 20 Φ L after all cleanup procedures have been exhausted. If a smaller aliquot of soils or mixed-phase samples is analyzed, attempt to assure that the sample is representative.
- 18.3** Perform integration of peak areas and calculate concentrations manually when interferences preclude computerized calculations.
- 18.4** Recovery of labeled compounds – In most samples, recoveries of the labeled compounds will be similar to those from reagent water or from the alternate matrix (Section 7.6).
 - 18.4.1** If the recovery of any of the labeled compounds is outside of the normal range (Table 5), a diluted sample must be analyzed (Section 17.5).
 - 18.4.2** If the recovery of any of the labeled compounds in the diluted sample is outside of normal range, the calibration verification standard (Section 7.10 and Table 5) must be analyzed and calibration verified (Section 15.3).
 - 18.4.3** If the calibration cannot be verified, a new calibration must be performed and the original sample extract reanalyzed.

18.4.4 If calibration is verified and the diluted sample does not meet the limits for labeled compound recovery, the Method does not apply to the sample being analyzed and the result may not be reported or used for permitting or regulatory compliance purposes. In this case, alternate extraction and cleanup procedures in this Method or an alternate GC column must be employed to resolve the interference. If all cleanup procedures in this Method and an alternate GC column have been employed and labeled compound recovery remains outside of the normal range, extraction and/or cleanup procedures that are beyond this scope of this Method will be required to analyze the sample.

19.0 Pollution prevention

19.1 Pollution prevention encompasses any technique that reduces or eliminates the quantity or toxicity of waste at the point of generation. Many opportunities for pollution prevention exist in laboratory operation. EPA has established a preferred hierarchy of environmental management techniques that places pollution prevention as the management option of first choice. Whenever feasible, laboratory personnel should use pollution prevention techniques to address waste generation. When wastes cannot be reduced at the source, the Agency recommends recycling as the next best option.

19.2 The pesticides in this Method are used in extremely small amounts and pose little threat to the environment when managed properly. Standards should be prepared in volumes consistent with laboratory use to minimize the disposal of excess volumes of expired standards.

19.3 For information about pollution prevention that may be applied to laboratories and research institutions, consult *Less is Better: Laboratory Chemical Management for Waste Reduction*, available from the American Chemical Society's Department of Governmental Relations and Science Policy, 1155 16th Street NW, Washington DC 20036, 202/872-4477 (http://membership.acs.org/c/ccs/pubs/less_is_better.pdf).

20.0 Waste management

20.1 The laboratory is responsible for complying with all Federal, State, and local regulations governing waste management, particularly the hazardous waste identification rules and land disposal restrictions, and to protect the air, water, and land by minimizing and controlling all releases from fume hoods and bench operations. Compliance is also required with any sewage discharge permits and regulations. An overview of requirements can be found in *Environmental Management Guide for Small Laboratories* (EPA 233-B-98-001).

20.2 Samples containing HCl or H₂SO₄ to pH <2, or KOH or NaOH to pH >12 must be handled as hazardous waste, or must be neutralized before being poured down a drain.

20.3 The pesticides decompose above 800°C. Low-level waste such as absorbent paper, tissues, animal remains, and plastic gloves may be burned in an appropriate incinerator. Gross

quantities (milligrams) should be packaged securely and disposed of through commercial or governmental channels that are capable of handling extremely toxic wastes.

- 20.4** For further information on waste management, consult *The Waste Management Manual for Laboratory Personnel* and *Less is Better-Laboratory Chemical Management for Waste Reduction*, available from the American Chemical Society's Department of Government Relations and Science Policy, 1155 16th Street N.W., Washington, D.C. 20036.

21.0 Method performance

Method 1699 was validated and preliminary data were collected in a single laboratory (Reference 2). Single laboratory performance data are included in Table 8.

22.0 References

- 1 EPA Methods 608, 1656, 1613, and 1668A.
- 2 "Analytical Method for the Analysis of Multi-residue Pesticides in Aqueous and XAD Column Samples by HRGC/HRMS," Axys Analytical Services (proprietary).
- 3 Lamparski, L.L., and Nestruck, T.J., "Novel Extraction Device for the Determination of Chlorinated Dibenzo-*p*-dioxins (PCDDs) and Dibenzofurans (PCDFs) in Matrices Containing Water," *Chemosphere*, 19:27-31, 1989.
- 4 "Working with Carcinogens," Department of Health, Education, & Welfare, Public Health Service, Centers for Disease Control, NIOSH, Publication 77-206, August 1977, NTIS PB-277256.
- 5 "OSHA Safety and Health Standards, General Industry," OSHA 2206, 29 *CFR* 1910.
- 6 "Safety in Academic Chemistry Laboratories," ACS Committee on Chemical Safety, 1979.
- 7 "Standard Methods for the Examination of Water and Wastewater," 18th edition and later revisions, American Public Health Association, 1015 15th St, N.W., Washington, DC 20005, 1-35: Section 1090 (Safety), 1992.
- 8 "Method 613 – 2,3,7,8-Tetrachlorodibenzo-*p*-dioxin," 40 *CFR* 136 (49 *FR* 43234), December 26, 1984, Section 4.1.
- 9 Echols, Kathy, Robert Gale, Donald E. Tillitt, Ted Schwartz, and Jerome O'Laughlin, *Environmental Toxicology and Chemistry* 16:8 1590-1597 (1997)
- 10 U.S. EPA Office of Superfund Remediation and Technology Innovation, Contract Laboratory Program *Summary of Requirements; Reporting and Deliverables Requirements; Target Compound List and Contract Required Quantitation Limits; and Analytical Methods* (<http://www.epa.gov/superfund/programs/clp/olm4.htm>).

- 11** Provost, L.P., and Elder, R.S., "Interpretation of Percent Recovery Data," *American Laboratory*, 15: 56-83, 1983.
- 12** "Standard Practice for Sampling Water," ASTM Annual Book of Standards, ASTM, 1916 Race Street, Philadelphia, PA 19103-1187, 1980.
- 13** e.g., "Standard Methods for the Examination of Water and Wastewater," 18th edition and later revisions, American Public Health Association, 1015 15th St, N.W., Washington, DC 20005, Methods 4500-CI adapted for field use.
- 14** "Handbook of Analytical Quality Control in Water and Wastewater Laboratories," USEPA EMSL, Cincinnati, OH 45268, EPA-600/4-79-019, March 1979.
- 15** "Analytical Procedures and Quality Assurance Plan for the Determination of PCDD/PCDF in Fish", U.S. Environmental Protection Agency, Environmental Research Laboratory, Duluth MN 55804, EPA/600/3-90/022, March 1990.

23.0 Tables and Figures

Table 1. Names, CAS Registry numbers, and ambient water quality criteria for pesticides determined by isotope dilution and internal standard HRGC/HRMS.

Pesticide	CAS Number	Labeled analog	Lowest Ambient Criterion (pg/L) (1)	MDLs and MLs, matrix and concentration (2)				
				Water (pg/L)		Solid (ng/kg)		Extract (pg/μL)
Organochlorine				MDL	ML	MDL	ML	ML
Aldrin	309-00-2	¹³ C ₁₂ -Aldrin	49	6	90	0.6	10	3
BHC, alpha	319-84-6	¹³ C ₆ -BHC, alpha	2600	7	60	1.3	10	3
BHC, beta	319-85-7	¹³ C ₆ -BHC, beta	9100	6	60	0.6	10	3
BHC, delta	319-86-8	¹³ C ₆ -BHC, delta		5	60	2.0	10	3
BHC, gamma (lindane)	58-89-9	¹³ C ₆ -BHC, gamma	160000	9	60	0.7	10	3
Captan	133-06-2			182	500	35	100	25
Chlordane, alpha (cis)	5103-71-9		800	7	30	0.6	5	1.5
Chlordane, gamma (trans)	5103-74-2	¹³ C ₁₀ -Chlordane, gamma	800	6	50	0.8	5	2
Chlorothalonil	1897-45-6			35	100	1.9	10	5
Dacthal	1861-32-1			4	20	0.9	2	1
DDD, o,p-	53-19-0			3	30	0.8	5	1.5
DDD, p,p-	72-54-8		11	5	30	1.5	5	1.5
DDE, o,p-	3424-82-6			3	30	0.5	5	1.5
DDE, p,p-	72-55-9	¹³ C ₁₂ -p,p-DDE	11	6	30	0.7	5	1.5
DDT, o,p-	789-02-6	¹³ C ₁₂ -o,p-DDT		2	30	0.3	5	1.5
DDT, p,p-	50-29-3	¹³ C ₁₂ -p,p-DDT	11	1	30	0.3	5	1.5
Dieldrin	60-57-1	¹³ C ₁₂ -Dieldrin	52	5	30	0.5	5	1.5
Endosulfan-alpha	959-98-8	¹³ C ₉ -alpha-Endosulfan	8700	24	100	--	--	5
Endosulfan-beta	33213-65-9	¹³ C ₉ -beta-Endosulfan	8700	30	100	--	--	5
Endosulfan-sulfate	1031-07-8		62000000	13	40	11	50	2
Endrin	72-20-8	¹³ C ₁₂ -Endrin	2300	3	30	0.4	5	1.5
Endrin-ketone	53494-70-5			12	40	1.6	5	2
Heptachlor	76-44-8	¹³ C ₄ -Heptachlor	79	7	30	--	--	1.5
Heptachlor-epoxide	1024-57-3	¹³ C ₁₀ -Heptachlor-epoxide	40	12	40	0.3	5	2
Hexachlorobenzene	118-74-1	¹³ C ₆ -Hexachlorobenzene		4	40	1.9	5	2
Methoxychlor	72-43-5	¹³ C ₁₂ -Methoxychlor	30000	7	30	0.3	5	1.5
Mirex	2385-85-5	¹³ C ₈ -Mirex	1000	35	100	--	--	5
Nonachlor, cis-	5103-73-1	¹³ C ₁₀ -Nonachlor, cis-		4	30	0.5	5	1.5
Nonachlor, trans-	39765-80-5	¹³ C ₁₀ -Nonachlor, trans-		11	40	0.8	5	2
Octachlorostyrene	29082-74-4			12	40	1.1	5	2
Oxychlordane	27304-13-8	¹³ C ₁₀ -Oxychlordane		7	60	0.5	10	3
Perthane	72-56-0			36	100	--	--	5
Quintozene	82-68-8			18	80	4.7	20	4
Tecnazene	117-18-0			22	80	3.2	10	4

Organophosphate								
Azinphos-methyl	86-50-0	Azinphos-methyl-d ₆		57	200	1.4	20	10
Chlorpyrifos	2921-88-2			20	80	2.0	10	4
Chlorpyrifos-methyl	5598-13-0			19	100	3.0	10	5
Chlorpyrifos-oxon	5598-15-2			24	80	3.5	10	4
Diazinon	333-41-5	Diazinon-d ₁₀	170000	27	80	24	100	4
Diazinon-oxon	962-58-3			22	80	--	--	4
Disulfoton	298-04-4			64	400	7.1	100	20
Disulfoton sulfone	2497 05 06			9	30	1.6	5	1.5
Fenitrothion	122-14-5			24	80	4.6	20	4
Fonofos	944-22-9	¹³ C ₆ -Fonofos		11	80	0.8	8	4
Malathion	121-75-5		100000	296	1000	41	200	50
Methamidophos	10265-92-6			269	1000	--	--	50
Parathion-ethyl	56-38-2		13000	15	80	3.5	10	4
Parathion-methyl	298-00-0			39	200	6.1	20	10
Phorate	298-02-2			49	200	3.5	20	10
Phosmet	732-11-6			63	200	12	50	10
Pirimiphos-methyl	29232-93-7			14	80	7.3	20	4
Triazine								
Ametryn	834-12-8			11	80	13	50	4
Atrazine	1912-24-9	¹³ C ₃ -Atrazine		14	80	--	--	4
Cyanazine	21725-46-2			38	80	--	--	4
Desethyl atrazine	6190-65-4			5	40	1.3	5	2
Hexazinone	51235-04-2			20	100	1.0	10	5
Metribuzin	21087-64-9			14	60	--	--	3
Simazine	122-34-9			12	80	1.4	10	4
Pyrethroid								
Cypermethrin	52315-07-8			66	200	2.4	20	10
Permethrins-peak 1	52645-53-1	¹³ C ₆ -cis/trans-Permethrin ³		59	200	230	1000	10
Permethrins-peak 2	52645-53-1	¹³ C ₆ -cis/trans-Permethrin ³		44	100	340	1000	5

1. *National Recommended Water Quality Criteria*, 2004, <http://epa.gov/waterscience/criteria/wqcriteria.html>, and Great Lakes Criteria (40 CFR 132.6), whichever is lower. A blank cell means there is no ambient criterion.
2. Method detection limits (MDLs) and minimum levels of quantitation (MLs) with no interferences present.
3. Elution order of cis/trans permethrin unknown

Table 2. Retention times (RTs); relative retention times (RRTs); and retention time and quantitation references for the pesticides

Pesticide	RT (1)	RRT (2)	RRT Limits (3)	Retention time and quantitation reference (4)	Quant Ref RT
Methamidophos	09:01	0.413	0.397 - 0.428	¹³ C ₁₂ -PCB-52	21:51
Tecnazene	14:44	0.927	0.906 - 0.948	¹³ C ₆ -HCB	15:54
¹³ C ₆ -Hexachlorobenzene	15:54	0.728	0.712 - 0.743	¹³ C ₁₂ -PCB-52	21:51
Hexachlorobenzene	15:55	1.001	0.991 - 1.012	¹³ C ₆ -HCB	15:54
Phorate	16:11	0.741	0.725 - 0.756	¹³ C ₁₂ -PCB-52	21:51
BHC-alpha	16:35	0.909	0.890 - 0.927	¹³ C ₆ -gamma-BHC	18:15
Desethylatrazine	16:50	0.935	0.917 - 0.954	¹³ C ₃ -Atrazine	18:00
Diazinon-d10	17:32	0.802	0.787 - 0.818	¹³ C ₁₂ -PCB-52	21:51
Quintozene	17:39	1.110	1.089 - 1.131	¹³ C ₆ -HCB	15:54
Diazinon	17:44	1.011	1.002 - 1.021	Diazinon-d10	17:32
Diazinon-oxon	17:55	1.022	1.003 - 1.041	Diazinon-d10	17:32
¹³ C ₃ -Atrazine	18:00	0.824	0.809 - 0.839	¹³ C ₁₂ -PCB-52	21:51
Atrazine	18:01	1.001	0.992 - 1.010	¹³ C ₃ -Atrazine	18:00
¹³ C ₆ -gamma-BHC	18:15	0.835	0.820 - 0.850	¹³ C ₁₂ -PCB-52	21:51
gamma-BHC	18:16	1.001	0.992 - 1.010	¹³ C ₆ -gamma-BHC	18:15
Simazine	18:21	1.019	1.001 - 1.038	¹³ C ₃ -Atrazine	18:00
Fonofos	18:25	1.000	0.991 - 1.009	¹³ C ₆ -Fonofos	18:25
¹³ C ₆ -Fonofos	18:25	0.843	0.828 - 0.858	¹³ C ₁₂ -PCB-52	21:51
Disulfoton	18:34	0.850	0.834 - 0.865	¹³ C ₁₂ -PCB-52	21:51
¹³ C ₆ -beta-BHC	19:26	0.889	0.874 - 0.905	¹³ C ₁₂ -PCB-52	21:51
beta-BHC	19:27	1.001	0.992 - 1.009	¹³ C ₆ -beta-BHC	19:26
¹³ C ₄ -Heptachlor	19:36	0.897	0.882 - 0.912	¹³ C ₁₂ -PCB-52	21:51
Heptachlor	19:37	1.001	0.992 - 1.009	¹³ C ₄ -Heptachlor	19:36
¹³ C ₆ -delta-BHC	21:00	0.961	0.946 - 0.976	¹³ C ₁₂ -PCB-52	21:51
delta-BCH	21:01	1.001	0.993 - 1.009	¹³ C ₆ -delta-BHC	21:00
Chlorothalonil.	21:08	0.967	0.952 - 0.982	¹³ C ₁₂ -PCB-52	21:51
¹³ C ₁₂ -Aldrin	21:15	0.973	0.957 - 0.988	¹³ C ₁₂ -PCB-52	21:51
Aldrin	21:17	1.002	0.994 - 1.009	¹³ C ₁₂ -Aldrin	21:15
Chlorpyriphos-methyl	21:26	0.981	0.966 - 0.996	¹³ C ₁₂ -PCB-52	21:51
¹³ C ₁₂ -PCB-52	21:51	N/A	N/A	N/A	N/A
Parathion-methyl	22:28	1.028	1.013 - 1.043	¹³ C ₁₂ -PCB-52	21:51
Ametryn	22:41	1.038	1.023 - 1.053	¹³ C ₁₂ -PCB-52	21:51
Pirimiphos-methyl	22:42	1.039	1.024 - 1.054	¹³ C ₁₂ -PCB-52	21:51
Metribuzin	23:04	1.056	1.040 - 1.071	¹³ C ₁₂ -PCB-52	21:51
Octachlorostyrene	23:18	1.096	1.081 - 1.112	¹³ C ₁₂ -Aldrin	21:15
Dacthal	23:18	1.066	1.051 - 1.082	¹³ C ₁₂ -PCB-52	21:51
Chlorpyriphos	23:33	1.078	1.063 - 1.093	¹³ C ₁₂ -PCB-52	21:51
Fenitrothion	24:07	1.104	1.088 - 1.119	¹³ C ₁₂ -PCB-52	21:51
¹³ C ₁₀ -Oxychlorthane	24:09	1.105	1.090 - 1.121	¹³ C ₁₂ -PCB-52	21:51
Oxychlorthane	24:11	1.001	0.994 - 1.008	¹³ C ₁₀ -Oxychlorthane	24:09
Malathion	24:12	1.108	1.092 - 1.123	¹³ C ₁₂ -PCB-52	21:51
Heptachlor-epoxide	25:14	0.962	0.956 - 0.969	¹³ C ₁₂ -Heptachlor-epoxide	25:11
¹³ C-Permethrins-Peak_2	42:21	1.114	1.099 - 1.130	¹³ C ₁₂ -PCB-52	21:51
Parathion-ethyl	24:26	1.118	1.103 - 1.133	¹³ C ₁₂ -PCB-52	21:51
Chlorpyriphos-oxon	24:30	1.121	1.106 - 1.137	¹³ C ₁₂ -PCB-52	21:51
¹³ C ₆ -Permethrins-Peak_1	42:04	1.124	1.108 - 1.139	¹³ C ₁₂ -PCB-52	21:51
Azinphos-ethyl-d6	24:33	1.124	1.108 - 1.139	¹³ C ₁₂ -PCB-52	21:51
¹³ C ₁₂ -Heptachlor-epoxide	25:11	1.153	1.137 - 1.168	¹³ C ₁₂ -PCB-52	21:51

¹³ C ₁₀ -t-Chlordane	26:39	1.220	1.204 - 1.235	¹³ C ₁₂ -PCB-52	21:51
t-Chlordane	26:41	1.001	0.995 - 1.008	¹³ C ₁₀ -t-Chlordane	26:39
¹³ C ₁₀ -t-Nonachlor	26:48	1.227	1.211 - 1.242	¹³ C ₁₂ -PCB-52	21:51
t-Nonachlor	26:50	1.001	0.995 - 1.007	¹³ C ₁₀ -t-Nonachlor	26:48
c-Chlordane	27:44	1.041	1.028 - 1.053	¹³ C ₁₀ -t-Chlordane	26:39
¹³ C ₉ -alpha-Endosulfan	27:51	1.275	1.259 - 1.290	¹³ C ₁₂ -PCB-52	21:51
Alpha-Endosulfan	27:53	1.001	0.995 - 1.007	¹³ C ₉ -alpha-Endosulfan	27:51
o,p-DDE	28:07	0.862	0.852 - 0.873	¹³ C ₁₂ -p,p-DDE	30:36
Cyanazine	28:13	1.291	1.276 - 1.307	¹³ C ₁₂ -PCB-52	21:51
¹³ C ₁₂ -Dieldrin	30:31	1.397	1.381 - 1.412	¹³ C ₁₂ -PCB-52	21:51
Dieldrin	30:34	1.002	0.996 - 1.007	¹³ C ₁₂ -Dieldrin	30:31
p,p-DDE	30:38	0.940	0.935 - 0.945	¹³ C ₁₂ -p,p-DDE	30:36
Captan	31:26	1.439	1.423 - 1.454	¹³ C ₁₂ -PCB-52	21:51
o,p-DDD	32:21	0.952	0.943 - 0.962	¹³ C ₁₂ -o,p-DDT	33:58
¹³ C ₁₂ -p,p-DDE	30:36	1.492	1.477 - 1.507	¹³ C ₁₂ -PCB-52	21:51
Disulfoton-Sulfone.	32:49	1.502	1.487 - 1.517	¹³ C ₁₂ -PCB-52	21:51
¹³ C ₁₂ -Endrin	32:53	1.505	1.490 - 1.520	¹³ C ₁₂ -PCB-52	21:51
Endrin	32:56	1.002	0.996 - 1.007	¹³ C ₁₂ -Endrin	32:53
Perthane	32:58	1.509	1.494 - 1.524	¹³ C ₁₂ -PCB-52	21:51
¹³ C ₁₀ -c-Nonachlor	33:17	1.523	1.508 - 1.539	¹³ C ₁₂ -PCB-52	21:51
c-Nonachlor	33:19	1.001	0.996 - 1.006	¹³ C ₁₀ -c-Nonachlor	33:17
¹³ C ₁₂ -o,p-DDT	33:58	1.555	1.539 - 1.570	¹³ C ₁₂ -PCB-52	21:51
o,p-DDT	33:59	1.000	0.996 - 1.005	¹³ C ₁₀ -o,p-DDT	33:58
¹³ C ₉ -beta-Endosulfan	34:30	1.579	1.564 - 1.594	¹³ C ₁₂ -PCB-52	21:51
p,p-DDD	34:31	0.865	0.857 - 0.874	¹³ C ₁₂ -p,p-DDT	35:53
beta-Endosulfan	34:32	1.001	0.996 - 1.006	¹³ C ₉ -beta-Endosulfan	34:30
p,p-DDT	35:54	0.900	0.896 - 0.904	¹³ C ₁₂ -p,p-DDT	35:53
Endosulfan-sulfate	36:54	1.070	1.060 - 1.079	¹³ C ₉ -beta-Endosulfan	34:30
¹³ C ₈ -Mirex	39:29	1.807	1.792 - 1.822	¹³ C ₁₂ -PCB-52	21:51
Mirex	39:30	1.000	0.996 - 1.005	¹³ C ₈ -Mirex	39:29
Hexazinone	39:38	1.814	1.799 - 1.829	¹³ C ₁₂ -PCB-52	21:51
¹³ C ₁₂ -Methoxychlor	39:43	1.818	1.802 - 1.833	¹³ C ₁₂ -PCB-52	21:51
Methoxychlor	39:44	1.000	0.996 - 1.005	¹³ C ₁₂ -Methoxychlor	39:43
Endrin-Ketone	39:47	1.210	1.200 - 1.220	¹³ C ₁₂ -Endrin	32:53
¹³ C ₁₂ -p,p-DDT	35:53	1.825	1.810 - 1.841	¹³ C ₁₂ -PCB-52	21:51
Phosmet	40:55	1.873	1.857 - 1.888	¹³ C ₁₂ -PCB-52	21:51
Permethrins-Peak_1	42:04	1.714	1.707 - 1.72	¹³ C ₆ -Permethrins-Peak_1	42:04
Permethrins-Peak_2	42:21	1.739	1.732 - 1.746	¹³ C ₆ -Permethrins-Peak_2	42:21
Azinphos-methyl	42:39	1.737	1.730 - 1.744	Azinphos-methyl-d6	42:33
Cypermethrins-Peak_1	43:52	N/A	N/A	¹³ C ₆ -Permethrins-Peak_1+2	
Cypermethrins-Peak_2	44:03	N/A	N/A	¹³ C ₆ -Permethrins-Peak_1+2	
Cypermethrins-Peak_3	44:11	N/A	N/A	¹³ C ₆ -Permethrins-Peak_1+2	

1. Retention time of pesticide or labeled compound.
2. Relative retention time (RRT) between the target and reference compounds.
3. RRT limits based on estimated RRT variability.
4. Labeled compounds that form both the retention time and quantitation reference.
5. Method detection limits (MDLs) and minimum levels of quantitation (MLs) with no interferences present.

Table 3. Concentrations of native and labeled pesticides in stock solutions, spiking solutions, and final extracts

Pesticide	Stock (ng/mL)	Spiking solution (pg/mL)	In 20 μL extract (ng/mL; pg/μL)
Tecnazene	800	800	40
Hexachlorobenzene	800	800	40
Quintozene	1600	1600	80
Heptachlor	600	600	30
Alpha-BHC	1200	1200	60
gamma-BHC (Lindane)	1200	1200	60
beta-BHC	1200	1200	60
delta-BHC	1200	1200	60
Aldrin	1200	1200	60
Dacthal	400	400	20
Octachlorostyrene	600	600	30
Oxychlordane	1200	1200	60
Heptachlor epoxide B	600	600	30
Trans-Chlordane	600	600	30
cis-Chlordane	600	600	30
Trans-Nonachlor	800	800	40
cis-Nonachlor	600	600	30
Endosulfan I (alpha)	600	600	30
Endosulfan II (beta)	600	600	30
Dieldrin	600	600	30
2,4'-DDD	600	600	30
4,4'-DDD	600	600	30
2,4'-DDE	600	600	30
4,4'-DDE	600	600	30
2,4'-DDT	600	600	30
4,4'-DDT	600	600	30
Perthane	600	600	30
Endrin	600	600	30
Endosulfan sulfate	600	600	30
Mirex	600	600	30
Methoxychlor	600	600	30
Endrin ketone	600	600	30
Desethylatrazine	800	800	40
Simazine	1600	1600	80
Atrazine	1600	1600	80
Ametryn	1600	1600	80
Metribuzin	400	400	20
Cyanazine	1600	1600	80
Hexazinone	2000	2000	100

Permethrin	800	800	40
Cypermethrin	4000	4000	200
Chlorothalonil	800	800	40
Diazinon	1600	1600	80
Disulfoton	8000	8000	400
Phorate	1600	1600	80
Methamidophos	1600	1600	80
Diazinon-oxon	1600	1600	80
Fonofos	1600	1600	80
Chlorpyrifos-methyl	2000	2000	100
Parathion-methyl	4000	4000	200
Pirimphos-methyl	1600	1600	80
Chlorpyrifos	1600	1600	80
Fenitrothion	1600	1600	80
Malathion	20000	20000	1000
Parathion-ethyl	1600	1600	80
Chlorpyrifos-oxon	1600	1600	80
Disulfoton sulfone	400	400	20
Azinphos-methyl	2000	2000	100
Captan	4000	4000	200
Phosmet (Imidan)	4000	4000	200
13C6-HCB	1800	1800	90
13C6-gamma-BHC	2600	2600	130
13C4-Heptachlor	1400	1400	70
13C6-beta-BHC	1600	1600	80
13C6-delta-BHC	1600	1600	80
13C12-Aldrin	1600	1600	80
13C10-Oxychlorane	1600	1600	80
13C10-Heptachlor-epoxide	1600	1600	80
13C9-alpha-Endosulfan	1600	1600	80
13C12-Dieldrin	1600	1600	80
13C10-t-Chlordane	1600	1600	80
13C10-t-Nonachlor	1600	1600	80
13C12-p,p-DDE	1600	1600	80
13C12-Endrin	1600	1600	80
13C9-beta-Endosulfan	1600	1600	80
13C10-c-Nonachlor	1600	1600	80
13C12-o,p-DDT	1600	1600	80
13C12-p,p-DDT	1600	1600	80
13C8-Mirex	1600	1600	80
13C12-Methoxychlor	1600	1600	80
Azinphos-methyl-d6	1600	1600	80
Diazinon-d10	1600	1600	80
13C6-Fonofos	1600	1600	80

13C3-Atrazine	1600	1600	80
13C6-Permethrins	1600	1600	80
13C12 PCB 52	1600	1600	80

Table 4. Concentration of pesticides in calibration and calibration verification standards (ng/mL)

Pesticide	Solution concentration (ng/mL)					
	CS-1 (Hi sens) (1)	CS-2	CS-3	CS-4 (VER)	CS-5	CS-6
Tecnazene	2.0	8.0	16.0	40.0	100.0	200.0
Hexachlorobenzene	2.0	8.0	16.0	40.0	100.0	200.0
Quintozene	4.0	16.0	32.0	80.0	200.0	400.0
Heptachlor	1.5	6.0	12.0	30.0	75.0	150.0
alpha-BHC	3.0	12.0	24.0	60.0	150.0	300.0
gamma-BHC (Lindane)	3.0	12.0	24.0	60.0	150.0	300.0
beta-BHC	3.0	12.0	24.0	60.0	150.0	300.0
delta-BHC	3.0	12.0	24.0	60.0	150.0	300.0
Aldrin	3.0	12.0	24.0	60.0	150.0	300.0
Dacthal	1.0	4.0	8.0	20.0	50.0	100.0
Octachlorostyrene	1.5	6.0	12.0	30.0	75.0	150.0
Oxychlorane	3.0	12.0	24.0	60.0	150.0	300.0
Heptachlor epoxide	1.5	6.0	12.0	30.0	75.0	150.0
trans-Chlordane	1.5	6.0	12.0	30.0	75.0	150.0
cis-Chlordane	1.5	6.0	12.0	30.0	75.0	150.0
trans-Nonachlor	2.0	8.0	16.0	40.0	100.0	200.0
cis-Nonachlor	1.5	6.0	12.0	30.0	75.0	150.0
Endosulfan I (alpha)	1.5	6.0	12.0	30.0	75.0	150.0
Endosulfan II (beta)	1.5	6.0	12.0	30.0	75.0	150.0
Dieldrin	1.5	6.0	12.0	30.0	75.0	150.0
2,4'-DDD	1.5	6.0	12.0	30.0	75.0	150.0
4,4'-DDD	1.5	6.0	12.0	30.0	75.0	150.0
2,4'-DDE	1.5	6.0	12.0	30.0	75.0	150.0
4,4'-DDE	1.5	6.0	12.0	30.0	75.0	150.0
2,4'-DDT	1.5	6.0	12.0	30.0	75.0	150.0
4,4'-DDT	1.5	6.0	12.0	30.0	75.0	150.0
Perthane	1.5	6.0	12.0	30.0	75.0	150.0
Endrin	1.5	6.0	12.0	30.0	75.0	150.0
Endosulfan sulfate	1.5	6.0	12.0	30.0	75.0	150.0
Mirex	1.5	6.0	12.0	30.0	75.0	150.0
Methoxychlor	1.5	6.0	12.0	30.0	75.0	150.0
Endrin ketone	1.5	6.0	12.0	30.0	75.0	150.0
Desethylatrazine	2.0	8.0	16.0	40.0	100.0	200.0
Simazine	4.0	16.0	32.0	80.0	200.0	400.0
Atrazine	4.0	16.0	32.0	80.0	200.0	400.0
Ametryn	4.0	16.0	32.0	80.0	200.0	400.0
Metribuzin	1.0	4.0	8.0	20.0	50.0	100.0
Cyanazine	4.0	16.0	32.0	80.0	200.0	400.0
Hexazinone	5.0	20.0	40.0	100.0	250.0	500.0
Permethrin	2.0	8.0	16.0	40.0	100.0	200.0

Cypermethrin	10.0	40.0	80.0	200.0	500.0	1000.0
Chlorothalonil	2.0	8.0	16.0	40.0	100.0	200.0
Diazinon	4.0	16.0	32.0	80.0	200.0	400.0
Disulfoton	20.0	80.0	160.0	400.0	1000.0	2000.0
Phorate	4.0	16.0	32.0	80.0	200.0	400.0
Methamidophos (Monitor)	4.0	16.0	32.0	80.0	200.0	400.0
Diazinon-oxon	4.0	16.0	32.0	80.0	200.0	400.0
Fonofos (Dyfonate)	4.0	16.0	32.0	80.0	200.0	400.0
Chlorpyrifos-methyl	5.0	20.0	40.0	100.0	250.0	500.0
Parathion-methyl	10.0	40.0	80.0	200.0	500.0	1000.0
Pirimphos-methyl	4.0	16.0	32.0	80.0	200.0	400.0
Chlorpyrifos (Dursban)	4.0	16.0	32.0	80.0	200.0	400.0
Fenitrothion	4.0	16.0	32.0	80.0	200.0	400.0
Malathion	50.0	200.0	400.0	1000.0	2500.0	5000.0
Parathion-ethyl (Parathion)	4.0	16.0	32.0	80.0	200.0	400.0
Chlorpyrifos-oxon	4.0	16.0	32.0	80.0	200.0	400.0
Disulfoton sulfone	1.0	4.0	8.0	20.0	50.0	100.0
Azinphos-methyl	5.0	20.0	40.0	100.0	250.0	500.0
Captan	10.0	40.0	80.0	200.0	500.0	1000.0
Phosmet (Imidan)	10.0	40.0	80.0	200.0	500.0	1000.0
13C6-HCB	90.0	90.0	90.0	90.0	90.0	100.0
13C6-gamma-BHC	130.0	130.0	130.0	130.0	130.0	150.0
13C4-Heptachlor	70.0	70.0	70.0	70.0	70.0	100.0
13C6-beta-BHC	80.0	80.0	80.0	80.0	80.0	80.0
13C6-delta-BHC	80.0	80.0	80.0	80.0	80.0	80.0
13C12-Aldrin	80.0	80.0	80.0	80.0	80.0	80.0
13C10-Oxychlordane	80.0	80.0	80.0	80.0	80.0	80.0
13C10-Heptachlor-epoxide	80.0	80.0	80.0	80.0	80.0	80.0
13C9-alpha-Endosulfan	80.0	80.0	80.0	80.0	80.0	80.0
13C12-Dieldrin	80.0	80.0	80.0	80.0	80.0	80.0
13C10-t-Chlordane	80.0	80.0	80.0	80.0	80.0	80.0
13C10-t-Nonachlor	80.0	80.0	80.0	80.0	80.0	80.0
13C12-p,p-DDE	80.0	80.0	80.0	80.0	80.0	80.0
13C12-Endrin	80.0	80.0	80.0	80.0	80.0	80.0
13C9-beta-Endosulfan	80.0	80.0	80.0	80.0	80.0	80.0
13C10-c-Nonachlor	80.0	80.0	80.0	80.0	80.0	80.0
13C12-o,p-DDT	80.0	80.0	80.0	80.0	80.0	80.0
13C12-p,p-DDT	80.0	80.0	80.0	80.0	80.0	80.0
13C8-Mirex	80.0	80.0	80.0	80.0	80.0	80.0
13C12-Methoxychlor	80.0	80.0	80.0	80.0	80.0	80.0
Azinphos-methyl-d6	80.0	80.0	80.0	80.0	80.0	80.0
Diazinon-d10	80.0	80.0	80.0	80.0	80.0	80.0
13C6-Fonofos	80.0	80.0	80.0	80.0	80.0	80.0
13C3-Atrazine	80.0	80.0	80.0	80.0	80.0	80.0

13C6-Permethrins	80.0	80.0	80.0	80.0	80.0	80.0
13C12 PCB 52	80.0	80.0	80.0	80.0	80.0	80.0

1. Additional concentration used for calibration of high sensitivity HRGC/HRMS systems

Table 5. QC acceptance criteria for pesticides in VER, IPR, OPR, and samples¹

Pesticide (1) (2)	VER (%) (3)	IPR Rec. Limits % (4)	IPR RSD Max	OPR Rec. limits (%) (5)	Recovery in samples (%) (6)
13C12-Aldrin	70-130	6 - 113	75	5 - 126	5 - 120
13C3-Atrazine	70-130	20 - 133	45	18 - 147	36 - 132
13C6-beta-BHC	70-130	19 - 127	46	17 - 141	32 - 130
13C10-c-Nonachlor	70-130	18 - 139	47	17 - 154	36 - 139
13C6-delta-BHC	70-130	18 - 135	47	16 - 150	36 - 137
13C12-Dieldrin	70-130	21 - 145	46	19 - 161	40 - 151
13C6-Fonofos	70-130	6 - 108	63	5 - 120	5 - 132
13C6-gamma-BHC	70-130	6 - 112	62	5 - 124	11 - 120
13C6-Hexachlorobenzene	70-130	6 - 108	70	5 - 120	5 - 120
13C4-Heptachlor	70-130	6 - 115	67	5 - 128	5 - 120
13C10-Heptachlor-epoxide	70-130	9 - 131	52	8 - 146	27 - 137
13C8-Mirex	70-130	6 - 125	56	5 - 138	5 - 120
13C12-o,p-DDT	70-130	16 - 180	51	14 - 200	5 - 199
13C10-Oxychlorane	70-130	6 - 129	54	5 - 144	23 - 135
13C12-p,p-DDE	70-130	29 - 152	43	26 - 169	47 - 160
13C12-p,p-DDT	70-130	15 - 180	52	13 - 200	5 - 120
13C6-Permethrin-Peak_1	70-130	35 - 180	43	32 - 200	35 - 189
13C6-Permethrin-Peak_2	70-130	35 - 180	43	31 - 200	31 - 192
13C10-T-Chlordane	70-130	17 - 130	47	15 - 144	21 - 132
13C10-T-Nonachlor	70-130	15 - 134	49	13 - 149	14 - 136
13C12-Endrin	70-130	22 - 141	45	20 - 157	35 - 155
13C12-Methoxychlor	70-130	8 - 180	54	8 - 200	5 - 120
13C9-alpha-Endosulfan	70-130	6 - 130	63	5 - 144	15 - 148
13C9-beta-Endosulfan	70-130	6 - 108	59	5 - 120	5 - 122
Diazinon-d10	75 - 125	6 - 130	54	5 - 145	21 - 141
Azinphos-methyl-d6	70 - 130	6 - 180	57	5 - 200	20 - 179
o,p'-DDD	75 - 125	55 - 108	30	50 - 120	
o,p'-DDE	75 - 125	26 - 111	30	24 - 123	
o,p'-DDT	75 - 125	55 - 108	30	50 - 120	
p,p'-DDD	75 - 125	47 - 108	30	42 - 120	
p,p'-DDE	75 - 125	55 - 108	30	50 - 120	
p,p'-DDT	75 - 125	55 - 108	30	50 - 120	
Aldrin	75 - 125	55 - 108	30	50 - 120	
Alpha-Endosulfan	75 - 125	55 - 108	30	50 - 120	
beta-Endosulfan	75 - 125	5-200	50	5-200	
Disulfoton	75 - 125	5-200	50	5-200	
alpha-BHC	75 - 125	55 - 108	30	50 - 120	
Ametryn	75 - 125	6 - 160	52	5 - 178	
Atrazine	75 - 125	55 - 108	30	50 - 120	
Azinphos-methyl	75 - 125	55 - 108	30	50 - 120	

beta-BHC	75 - 125	55 - 108	30	50 - 120	
c-Chlordane	75 - 125	55 - 108	30	50 - 120	
c-Nonachlor	75 - 125	55 - 108	30	50 - 120	
Captan	75 - 125	6 - 108	39	5 - 120	
Chlorothalonil	75 - 125	6 - 108	47	5 - 120	
Chlorpyrifos	75 - 125	21 - 147	46	19 - 163	
Chlorpyrifos-methyl	75 - 125	10 - 130	51	9 - 145	
Chlorpyrifos-oxon	75 - 125	6 - 143	43	5 - 158	
Octachlorostyrene	70 - 130	55 - 158	30	50 - 175	
Cyanazine	75 - 125	10 - 176	53	9 - 195	
Dacthal	75 - 125	18 - 129	46	16 - 143	
delta-BHC	75 - 125	55 - 108	30	50 - 120	
Desethylatrazine	75 - 125	55 - 108	30	50 - 120	
Diazinon	75 - 125	55 - 108	30	50 - 120	
Diazinon-oxon	75 - 125	55 - 144	30	50 - 160	
Dieldrin	75 - 125	55 - 108	30	50 - 120	
Disulfoton sulfone	75 - 125	6 - 180	79	5 - 200	
Endosulfan-sulfate	75 - 125	55 - 180	30	50 - 200	
Endrin	75 - 125	55 - 108	30	50 - 120	
Endrin-ketone	75 - 125	55 - 120	30	50 - 134	
Fenitrothion	75 - 125	15 - 168	50	14 - 186	
Fonofos	75 - 125	55 - 108	30	50 - 120	
Gamma-BHC	75 - 125	55 - 108	30	50 - 120	
Hexachlorobenzene	75 - 125	55 - 108	30	50 - 120	
Heptachlor	75 - 125	55 - 108	30	50 - 120	
Heptachlor-epoxide	75 - 125	55 - 108	30	50 - 120	
Hexazinone	75 - 125	6 - 154	74	5 - 171	
Malathion	75 - 125	15 - 136	48	14 - 151	
Methamidophos	75 - 125	6 - 108	68	5 - 120	
Methoxychlor	75 - 125	55 - 108	30	50 - 120	
Metribuzin	75 - 125	6 - 134	58	5 - 149	
Mirex	75 - 125	55 - 108	30	50 - 120	
Oxychlordane	75 - 125	55 - 108	30	50 - 120	
Parathion-ethyl	75 - 125	13 - 147	50	12 - 164	
Parathion-methyl	75 - 125	7 - 136	53	7 - 151	
Perthane	75 - 125	26 - 180	46	24 - 200	
Phorate	75 - 125	6 - 108	291	5 - 120	
Phosmet	75 - 125	14 - 138	49	13 - 153	
Pirimiphos-methyl	75 - 125	6 - 151	64	5 - 168	
Quintozene	75 - 125	55 - 180	30	50 - 200	
Simazine	75 - 125	55 - 108	30	50 - 120	
t-Chlordane	75 - 125	55 - 108	30	50 - 120	
t-Nonachlor	75 - 125	55 - 108	30	50 - 120	
Technazene	75 - 125	55 - 154	30	50 - 171	

Total-Cypermethrins	75 - 125	55 - 108	30	50 - 120	
Total-Permethrins	75 - 125	55 - 180	30	50 - 200	

1. QC acceptance criteria for IPR, OPR, and samples based on a 20 μ L extract final volume
2. For concentrations see Table 3 spike solutions.
3. Section 15.3.
4. Section 9.2.
5. Section 15.6.
6. Section 9.3: Recovery of labeled compounds from samples.

Table 6. Scan functions; exact m/z's (m1 and m2), ratios and tolerances; retention times (RTs); and quantitation references.

Function	Pesticide	m1 (1)	m2 (1)	m1/m2		RT (min)	Quantified against labeled standard
				Ratio	Tolerance (+/-)		
1	Methamidophos	93.9642	94.9721		0.35	09:01	13C12-PCB-52
2	HCB	283.8102	285.8072	1.25	0.25	15:55	13C6-HCB
2	Tecnazene	258.8761	260.8732	0.78	0.35	14:44	13C6-HCB
2	13C6-HCB	289.8303	291.8273	1.25	0.25	15:54	13C12-PCB-52
2	Phorate	260.0128	262.0086	6.92	0.35	16:11	13C12-PCB-52
3	Desethylatrazine	172.0390	174.0360	3.11	0.35	16:50	13C3-Atrazine
3	Alpha-HCH	218.9116	220.9086	2.08	0.25	16:35	13C6-gamma-BHC
4	Atrazine	215.0938	217.0908	3.08	0.35	18:01	13C3-Atrazine
4	Simazine	201.0781	203.0752	3.1	0.35	18:21	13C3-Atrazine
4	Fonofos	246.0302	247.0336		0.35	18:25	13C6-Fonofos
4	gamma-HCH	218.9116	220.9086	2.08	0.25	18:16	13C6-gamma-BHC
4	Quintozene	236.8413	238.8384	1.56	0.35	17:39	13C6-HCB
4	13C3-Atrazine	218.1038	220.1009	3.08	0.35	18:00	13C12-PCB-52
4	13C6-Fonofos	252.0503	253.0537	1000	0.35	18:25	13C12-PCB-52
4	13C6-gamma-BHC	222.9346	224.9317	0.77	0.25	18:15	13C12-PCB-52
4	Diazinon-d10	282.1074	314.1638	1000	0.35	17:32	13C12-PCB-52
4	Disulfoton	274.0285	275.0318		0.35	18:34	13C12-PCB-52
4	Diazinon	276.0698	304.1011		0.35	17:44	Diazinon-d10
4	Diazinon-oxon	273.1004	288.1239		0.35	17:55	Diazinon-d10
5	Aldrin	262.8569	264.854	1.56	0.25	21:17	13C12-Aldrin
5	Beta-BHC	218.9116	220.9086	2.08	0.25	19:27	13C6-beta-BHC
5	Delta-BHC	218.9116	220.9086	2.08	0.25	21:01	13C6-delta-BHC
5	Heptachlor	271.8102	273.8072	1.25	0.25	19:37	13C4-Heptachlor
5	13C12-Aldrin	269.8804	271.8775	1.56	0.25	21:15	13C12-PCB-52
5	13C6-beta-BHC	222.9346	224.9317	0.77	0.25	19:26	13C12-PCB-52
5	13C6-delta-BHC	222.9346	224.9317	0.77	0.25	21:00	13C12-PCB-52
5	13C4-Heptachlor	276.8269	278.824	1.24	0.25	19:36	13C12-PCB-52
5	Chlorothalonil.	263.8816	265.8786	0.78	0.35	21:08	13C12-PCB-52
5	Chlorpyrifos-methyl	285.9261	287.9232	1.44	0.35	21:26	13C12-PCB-52
5	13C12-PCB-52	301.9626	303.9597	0.78	0.25	21:51	
6	Octachlorostyrene	270.8443	272.8413	0.63	0.25	23:18	13C12-Aldrin
6	Ametryn	227.1205	228.1238		0.35	22:41	13C12-PCB-52
6	Dacthal	298.8836	300.8807	0.78	0.35	23:18	13C12-PCB-52
6	Metribuzin	198.0701	199.0735		0.35	23:04	13C12-PCB-52
6	Parathion-methyl	263.0017	264.0051		0.35	22:28	13C12-PCB-52
6	Pirimiphos-methyl	276.0572	290.0728		0.35	22:42	13C12-PCB-52
7	Oxychlorthane	262.8569	264.8540	1.56	0.25	24:11	13C10-Oxychlorthane
7	13C10-Oxychlorthane	269.8804	271.8775	1.56	0.25	24:09	13C12-PCB-52
7	Chlorpyrifos	313.9574	315.9545	1.44	0.35	23:33	13C12-PCB-52
7	Chlorpyrifos-oxon	269.9490	271.9462	1.54	0.35	24:30	13C12-PCB-52

7	Fenitrothion	260.0146	277.0174		0.35	24:07	13C12-PCB-52
7	Malathion	283.9942	285.0020		0.35	24:12	13C12-PCB-52
7	Parathion-ethyl	291.0330	292.0364		0.35	24:26	13C12-PCB-52
8	Heptachlor-epoxide	262.8569	264.8540	1.56	0.25	24:14	13C12-Heptachlor-epoxide
8	alpha-Endosulfan	262.8569	264.8540	1.56	0.25	27:53	13C9-alpha-Endosulfan
8	Dieldrin	262.8569	264.8540	1.56	0.25	30:34	13C12-Dieldrin
8	o,p-DDE	246.0003	247.9974	1.56	0.25	28:07	13C12-p,p-DDE
8	p,p-DDE	246.0003	247.9974	1.56	0.25	30:38	13C12-p,p-DDE
8	13C12-Heptachlor-epoxide	269.8804	271.8775	1.56	0.25	25:11	13C12-PCB-52
8	13C9-alpha-Endosulfan	269.8804	271.8775	1.56	0.25	27:51	13C12-PCB-52
8	13C12-Dieldrin	269.8804	271.8775	1.56	0.25	30:31	13C12-PCB-52
8	13C12-p,p-DDE	258.0406	260.0376	1.56	0.25	32:36	13C12-PCB-52
8	13C10-t-Chlordane	269.8804	271.8775	1.56	0.25	26:39	13C12-PCB-52
8	13C10-t-Nonachlor	269.8804	271.8775	1.56	0.25	26:48	13C12-PCB-52
8	Cyanazine	240.0890	242.0861	3.06	0.35	28:13	13C12-PCB-52
8	c-Chlordane	262.8569	264.854	1.56	0.25	27:44	13C10-t-Chlordane
8	t-Chlordane	262.8569	264.854	1.56	0.25	26:41	13C10-t-Chlordane
8	t-Nonachlor	262.8569	264.854	1.56	0.25	26:50	13C10-t-Nonachlor
9	Endrin	262.8569	264.854	1.56	0.25	32:56	13C12-Endrin
9	c-Nonachlor	262.8569	264.854	1.56	0.25	33:19	13C10-c-Nonachlor
9	o,p-DDD	235.0081	237.0052	1.56	0.25	32:21	13C12-o,p-DDT
9	13C12-Endrin	269.8804	271.8775	1.56	0.25	32:53	13C12-PCB-52
9	Captan	263.9653	265.9623	1.44	0.35	31:26	13C12-PCB-52
9	Disulfoton-Sulfone.	213.0173	214.0251		0.35	32:49	13C12-PCB-52
9	Perthane	224.1520	223.1487		0.35	32:58	13C12-PCB-52
10	beta-Endosulfan	264.8540	262.8569	0.64	0.25	34:32	13C9-beta-Endosulfan
10	Endosulfan-sulfate	264.8540	262.8569	0.64	0.25	36:54	13C9-beta-Endosulfan
10	o,p-DDT	235.0081	237.0052	1.56	0.25	33:59	13C12-o,p-DDT
10	p,p-DDD	235.0081	237.0052	1.56	0.25	34:31	13C12-p,p-DDT
10	p,p-DDT	235.0081	237.0052	1.56	0.25	35:54	13C12-p,p-DDT
10	13C9-beta-Endosulfan	269.8804	271.8775	1.56	0.25	34:30	13C12-PCB-52
10	13C10-c-Nonachlor	269.8804	271.8775	1.56	0.25	33:17	13C12-PCB-52
10	13C12-o,p-DDT	247.0484	249.0454	1.56	0.25	33:58	13C12-PCB-52
10	13C12-p,p-DDT	247.0484	249.0454	1.56	0.25	39:53	13C12-PCB-52
11	Endrin-ketone	247.8521	249.8491	0.63	0.25	39:47	13C12-Endrin
11	Methoxychlor	227.1072	228.1106		0.35	39:44	13C12-Methoxychlor
11	Mirex	236.8413	238.8384	1.56	0.25	39:30	13C8-Mirex
11	13C12-Methoxychlor	239.1475	240.1508		0.35	39:43	13C12-PCB-52
11	13C8-Mirex	241.8581	243.8551	1.56	0.25	39:29	13C12-PCB-52
11	13C6-Permethrins-Peak_1	189.1011	190.1045		0.35	24:33	13C12-PCB-52
11	13C6-Permethrins-Peak_2	189.1011	190.1045		0.35	24:21	13C12-PCB-52
11	Azinphos-methyl-d6	160.0511	161.0544		0.35	24:33	13C12-PCB-52
11	Hexazinone	171.0882	172.0916		0.35	39:38	13C12-PCB-52
11	Phosmet	160.0399	161.0432		0.35	40:55	13C12-PCB-52

11	Permethrins-Peak_1	183.0081	184.0843		0.35	42:04	13C6-Permethrins-Peak_1
11	Cypermethrins-Peak_1	163.0081	165.0052	1.56	0.35	43:52	13C6-Permethrins-Peak_1+2
11	Cypermethrins-Peak_2	163.0081	165.0052	1.56	0.35	44:03	13C6-Permethrins-Peak_1+2
11	Cypermethrins-Peak_3	163.0081	165.0052	1.56	0.35	44:11	13C6-Permethrins-Peak_1+2
11	Permethrins-Peak_2	183.0081	184.0843		0.35	42:21	13C6-Permethrins-Peak_2
11	Azinphos-methyl	160.0511	161.0544		0.35	42:39	Azinphos-methyl-d6
11	Total-Cypermethrins	163.0081	165.0052	1.56	0.35		
11	Total-Permethrins	183.0081	184.0843		0.35		

1. Isotopic masses used for accurate mass calculation

¹ H	1.0078
¹² C	12.0000
¹³ C	13.0034
³⁵ Cl	34.9689
³⁷ Cl	36.9659
¹⁹ F	18.9984
¹⁴ N	14.0031
¹⁶ O	15.9949

Table 7. Suggested sample quantities to be extracted for various matrices¹

Sample matrix ²	Example	Percent solids	Phase	Quantity extracted
Single-phase				
Aqueous	Drinking water	<1	— ³	1000 mL
	Groundwater			
	Treated wastewater			
Solid	Dry soil	>20	Solid	10 g
	Compost			
	Ash			
Organic	Waste solvent	<1	Organic	10 g
	Waste oil			
	Organic polymer			
Tissue	Fish	—	Organic	10 g
	Human adipose			
Multi-phase				
Liquid/Solid				
Aqueous/Solid	Wet soil	1-30	Solid	10 g
	Untreated effluent			
	Digested municipal sludge			
	Filter cake			
	Paper pulp			
Organic/solid	Industrial sludge	1-100	Both	10 g
	Oily waste			
Liquid/Liquid				
Aqueous/organic	In-process effluent	<1	Organic	10 g
	Untreated effluent			
	Drum waste			
Aqueous/organic/solid	Untreated effluent	>1	Organic & solid	10 g
	Drum waste			

1. The quantity of sample to be extracted is adjusted to provide 10 g of solids (dry weight). One liter of aqueous samples containing one percent solids will contain 10 grams of solids. For aqueous samples containing greater than one percent solids, a lesser volume is used so that 10 grams of solids (dry weight) will be extracted.
2. The sample matrix may be amorphous for some samples. In general, when the pesticides are in contact with a multi-phase system in which one of the phases is water, they will be preferentially dispersed in or adsorbed on the alternate phase because of their low water solubility.

3. Aqueous samples are filtered after spiking with the labeled compounds. The filtrate and the materials trapped on the filter are extracted separately, and the extracts are combined for cleanup and analysis.

Table 8. Performance data from single laboratory validation.

	Solid-Based			Reagent Water-Based			Biosolids-Based on 8 (native)		
	on 5 samples			on 4 samples			or 6 (label) samples		
	Solids Average Recovery	Solids Standard Deviation	Solids Relative Standard Deviation	Water Average Recovery	Water Standard Deviation	Water Relative Standard Deviation	Biosolids Average Recovery	Biosolids Standard Deviation	Biosolids Relative Standard Deviation
13C12-ENDRIN	90.43	31.77	28.73	86.81	8.60	7.46	104.57	13.16	13.76
13C12-METHOXYCHLOR	128.41	32.12	41.25	100.11	7.61	7.62	20.64	53.78	11.10
13C9-ALPHA-ENDOSULPHAN	78.70	35.89	28.25	58.13	8.21	4.77	99.81	7.05	7.04
13C9-BETA-ENDOSULPHAN	41.74	33.54	14.00	29.95	7.71	2.31	84.12	10.42	8.76
13C-ALDRIN	63.24	40.59	25.67	44.20	23.24	10.27	55.15	13.54	7.47
13C-ATRAZINE	79.29	33.93	26.90	87.33	6.03	5.27	85.34	7.72	6.59
13C-BETA-HCH	82.51	31.58	26.05	74.98	6.06	4.55	84.55	11.92	10.08
13C-C-NONACHLOR	90.04	31.72	28.56	79.79	5.75	4.59	89.72	8.54	7.66
13C-DELTA-HCH	88.30	31.10	27.46	76.82	6.14	4.72	91.15	6.01	5.48
13C-DIELDRIN	93.89	31.51	29.59	85.15	5.83	4.96	103.06	5.37	5.53
13C-FONOFOS	50.73	40.18	20.38	49.40	27.30	13.49	90.65	8.48	7.69
13C-GAMMA-HCH	68.29	32.52	22.21	48.74	23.03	11.22	71.55	17.26	12.35
13C-HCB	52.33	31.93	16.71	29.07	37.79	10.98	54.51	17.21	9.38
13C-HEPTACHLOR	68.85	33.42	23.01	42.58	27.19	11.58	55.32	34.65	19.17
13C-HEPTACHLOR-EPOXIDE	83.80	31.90	26.73	68.38	10.13	6.93	90.61	7.70	6.98
13C-MIREX	79.07	31.94	25.25	59.67	9.65	5.76	46.84	24.47	11.46
13C-O,P-DDT	123.18	30.97	38.16	99.18	7.07	7.02	48.25	43.86	21.16
13C-OXYCHLORDANE	83.09	30.78	25.58	62.67	10.04	6.29	87.54	11.61	10.16
13C-P,P-DDE	99.83	30.31	30.25	94.99	6.26	5.95	111.80	5.68	6.34
13C-P,P-DDT	140.36	30.94	43.42	110.00	4.43	4.87	33.09	50.74	16.79
13C-PERMETHRINS-PEAK_1	116.88	32.00	37.40	128.45	6.05	7.77	97.01	11.02	10.69
13C-PERMETHRINS-PEAK_2	118.48	32.32	38.30	130.18	6.11	7.95	94.06	11.15	10.49
13C-T-CHLORDANE	86.23	29.38	25.34	71.73	7.67	5.50	72.27	21.41	15.47
13C-T-NONACHLOR	87.23	31.29	27.30	74.09	7.72	5.72	66.33	26.20	17.38
2,4'-DDD	81.14	1.09	0.89	102.00	1.33	1.36	270.95	81.98	222.13
2,4'-DDE	84.86	15.50	13.15	58.65	7.59	4.45	101.19	2.88	2.91
2,4'-DDT	97.46	0.50	0.48	98.77	0.77	0.76	98.26	9.75	9.58
4,4'-DDD	45.89	3.04	1.40	46.43	1.70	0.79	430.55	97.71	420.69
4,4'-DDE	99.45	0.67	0.66	92.40	1.23	1.14	102.43	7.38	7.56
4,4'-DDT	95.81	0.94	0.90	97.66	0.66	0.64	97.19	7.90	7.68
ALDRIN	97.30	1.88	1.83	99.82	5.14	5.13	97.94	15.24	14.93
ALPHA-ENDOSULPHAN	94.02	4.50	4.23	91.74	4.03	3.70	90.06	13.49	12.15

ALPHA-HCH	86.44	2.34	2.03	80.00	12.67	10.14	94.43	11.18	10.56
AMETRYN	38.46	57.63	22.17	105.31	6.94	7.31	124.18	15.18	18.85
ATRAZINE	99.47	1.51	1.50	98.95	0.76	0.75	108.25	25.55	27.66
AZINPHOS-METHYL	95.50	1.32	1.27	91.43	2.10	1.92	92.45	12.98	12.00
BETA-ENDOSULPHAN	*	*	*	*	*	*	97.41	12.31	11.99
BETA-HCH	101.26	1.23	1.24	103.95	0.62	0.65	96.72	10.14	9.81
CAPTAN	2.03			39.76	15.77	6.27	*	*	*
C-CHLORDANE	97.89	1.77	1.73	95.29	2.47	2.36	109.10	98.97	107.98
CHLOROTHALONIL	18.32	43.37	7.94	46.46	12.52	5.82	5.43	124.49	6.76
CHLORPYRIPHOS	95.97	30.61	29.38	85.71	9.45	8.10	112.15	9.12	10.23
CHLORPYRIPHOS-METHYL	82.40	31.23	25.73	70.07	17.14	12.01	95.67	16.32	15.61
CHLORPYRIPHOS-OXON	0.64	42.62	0.27	84.10	14.59	12.27	59.89	47.09	28.20
CL8-STYRENE	122.49	16.49	20.20	109.15	12.37	13.50	132.75	7.10	9.42
C-NONACHLOR	99.49	1.65	1.64	99.95	0.99	0.99	99.96	7.50	7.50
CYANAZINE	104.03	38.26	39.80	99.88	5.26	5.25	121.57	31.95	38.84
D10-DIAZINON	77.75	36.37	28.28	71.13	15.58	11.08	88.11	16.37	14.43
D6-AZINPHOS-METHYL	93.60	42.99	40.24	118.19	4.83	5.71	90.12	18.63	16.79
DACTHAL	81.66	31.90	26.05	77.16	12.06	9.31	100.50	25.52	25.65
DELTA-HCH	102.16	1.56	1.59	99.31	3.08	3.06	97.90	9.92	9.71
DESETHYLATRAZINE	99.84	2.63	2.63	86.50	4.41	3.81	111.16	20.68	22.99
DIAZINON	98.58	1.85	1.83	98.08	1.36	1.33	93.14	7.25	6.75
DIAZINON-OXON	*	*	*	131.28	5.15	6.76	82.64	36.03	29.78
DIELDRIN	101.70	0.95	0.97	103.87	0.71	0.74	95.23	16.77	15.97
DIMETHOATE	75.95	38.51	29.25	85.52	10.34	8.84	114.22	20.38	23.28
DISULFOTON	*	*	*	*	*	*	60.23	46.33	27.91
DISULFOTON SULFONE	477.45	41.55	198.40	651.23	39.89	259.79	139.98	57.09	79.91
ENDOSULPHAN-SULPHATE	231.97	1.94	4.50	271.05	3.40	9.22	88.54	20.18	17.87
ENDRIN	101.22	3.00	3.04	103.49	1.60	1.66	98.44	9.29	9.15
ENDRIN-KETONE	104.25	10.11	10.54	95.59	8.87	8.48	71.24	41.83	29.80
ETHION	90.12	61.34	55.28	49.68	4.65	2.31	167.53	32.83	54.99
FENITROTHION	101.29	35.89	36.36	98.41	9.50	9.35	151.55	17.43	26.42
FONOFOS	106.68	2.93	3.13	98.46	2.43	2.40	98.06	7.60	7.45
GAMMA-HCH	95.92	1.44	1.39	94.86	0.82	0.78	95.09	10.82	10.28
HCB	102.21	0.10	0.10	102.89	2.58	2.65	100.09	7.31	7.32
HEPTACHLOR	100.14	1.30	1.30	99.58	3.27	3.26	91.71	9.12	8.37
HEPTACHLOR-EPOXIDE	101.40	1.84	1.87	101.50	2.31	2.35	102.08	7.48	7.64
HEXAZINONE	27.26	90.24	24.60	89.16	19.32	17.23	130.31	21.84	28.45
MALATHION	83.84	34.77	29.15	81.02	7.61	6.17	95.88	37.53	35.98
METHAMIDOPHOS	29.71	37.83	11.24	*	*	*	32.62	40.38	13.17
METHOXYCHLOR	101.14	2.51	2.54	98.17	1.44	1.41	105.54	9.42	9.95
METRIBUZIN	80.54	37.63	30.31	67.41	5.70	3.84	130.08	13.38	17.41
MIREX	103.40	2.45	2.53	94.01	3.69	3.46	103.95	10.84	11.27
OXYCHLORDANE	97.11	0.88	0.86	103.17	2.14	2.21	93.78	12.65	11.86
PARATHION-ETHYL	91.86	34.54	31.72	82.74	7.33	6.06	146.11	22.28	32.55

PARATHION-METHYL	82.54	35.71	29.48	74.72	13.29	9.93	139.95	16.25	22.74
PERTHANE	120.82	31.57	38.14	108.82	6.85	7.45	144.00	23.38	33.67
PHORATE	5.72	167.39	9.57	14.53	137.43	19.96	81.78	21.37	17.48
PHOSMET	80.19	36.61	29.36	86.54	8.34	7.22	86.09	75.25	64.78
PIRIMIPHOS-METHYL	73.75	48.99	36.13	87.90	8.09	7.11	112.14	33.53	37.60
QUINTOZENE	129.60	3.06	3.96	163.36	15.06	24.60	142.76	25.37	36.22
SIMAZINE	106.25	2.05	2.18	104.43	3.02	3.15	110.07	11.58	12.75
T-CHLORDANE	101.65	5.24	5.33	104.93	1.01	1.06	104.36	26.02	27.16
TECNAZENE	120.17	3.76	4.52	107.67	23.63	25.44	132.60	36.97	49.02
TERBUFOS	7.50	167.78	12.58	20.86	127.25	26.54	84.92	26.80	22.75
T-NONACHLOR	100.91	1.81	1.83	102.74	4.02	4.13	94.64	35.56	33.65
TOTAL-CYPERMETHRINS	93.50	3.29	3.07	93.57	4.36	4.08	71.64	7.06	5.06
TOTAL-PERMETHRINS	145.58	16.20	23.58	144.77	2.53	3.66	655.40	124.74	817.53

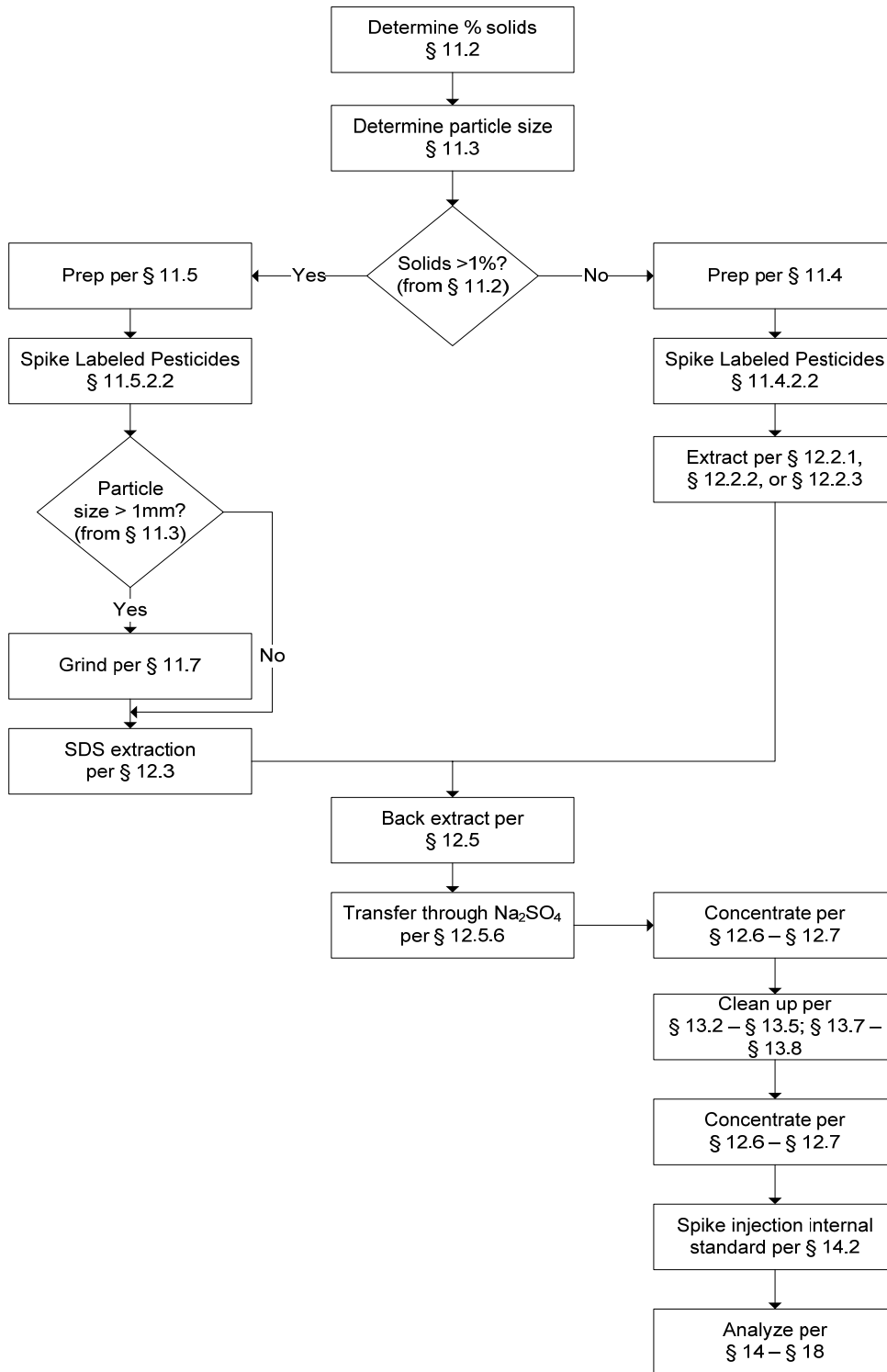

Figure 1 Flow Chart for Analysis of Aqueous and Solid Samples

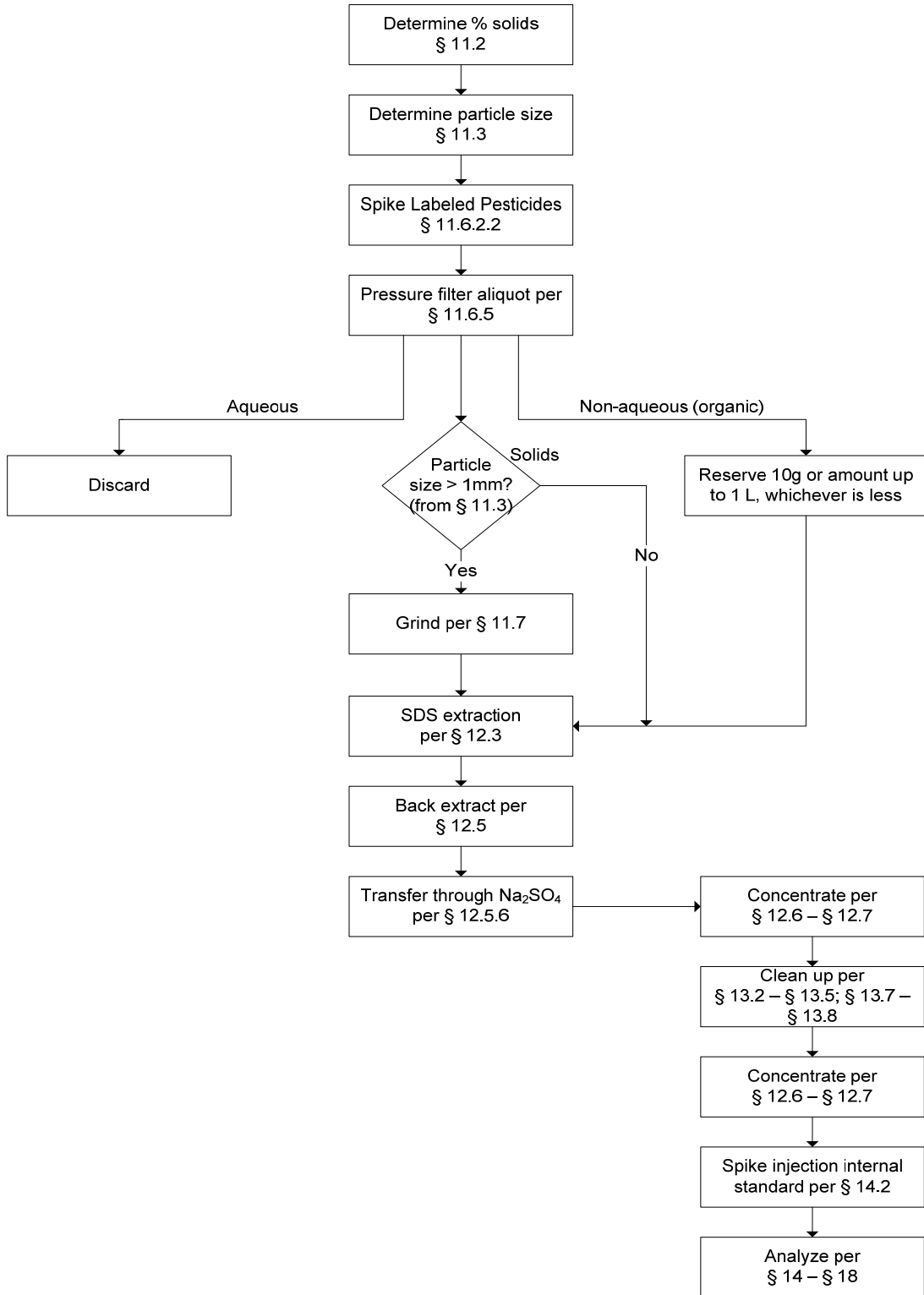

Figure 2 Flow Chart for Analysis of Multi-Phase Samples

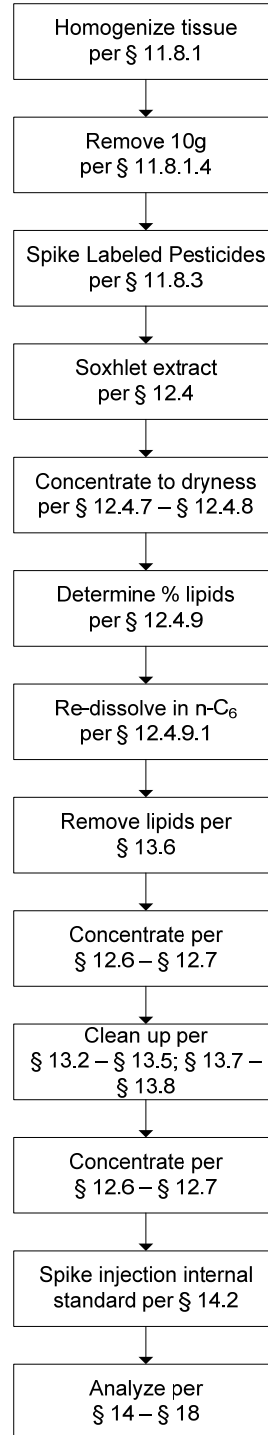

Figure 3 Flow Chart for Analysis of Tissue Samples

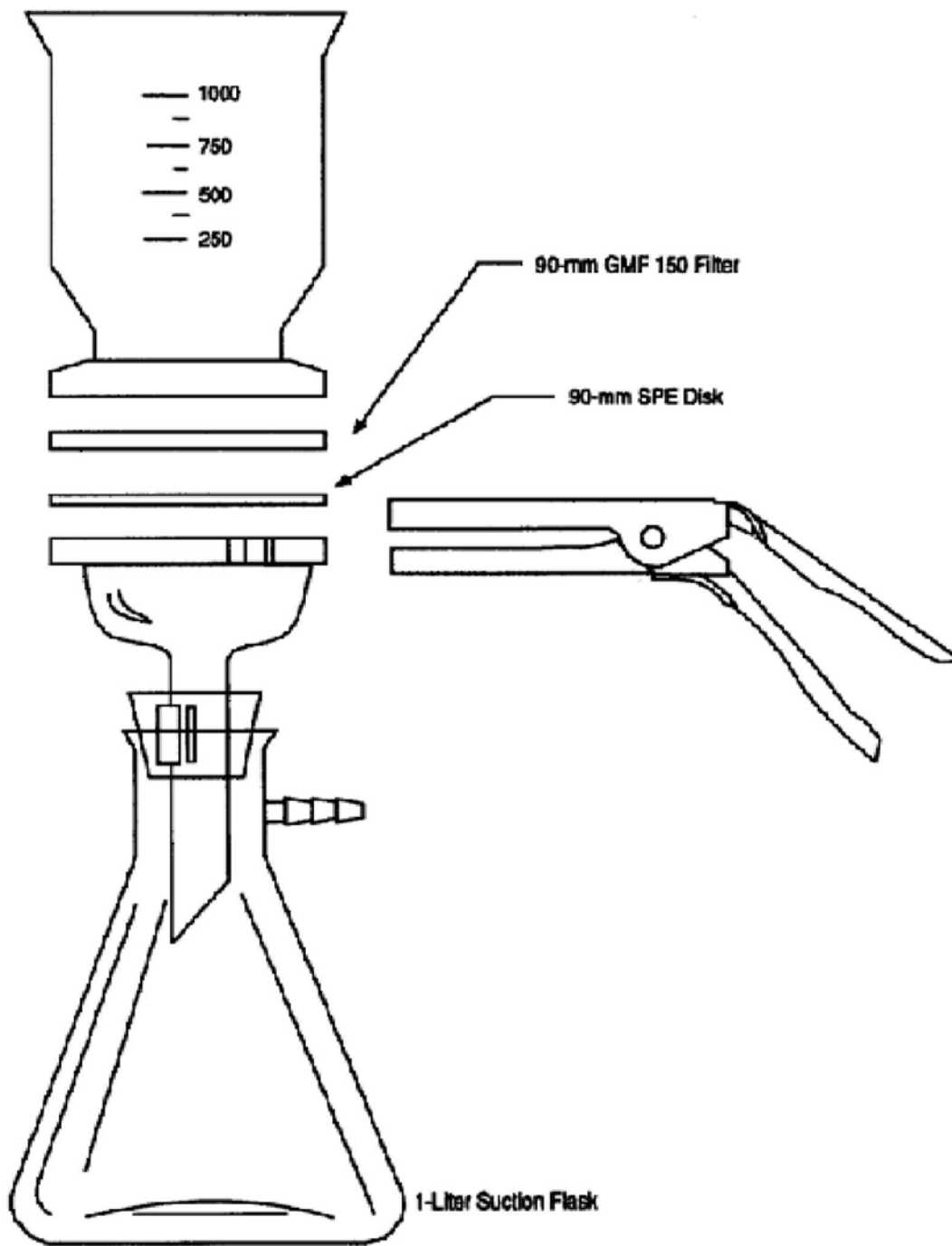

Figure 4 Solid-phase Extraction Apparatus

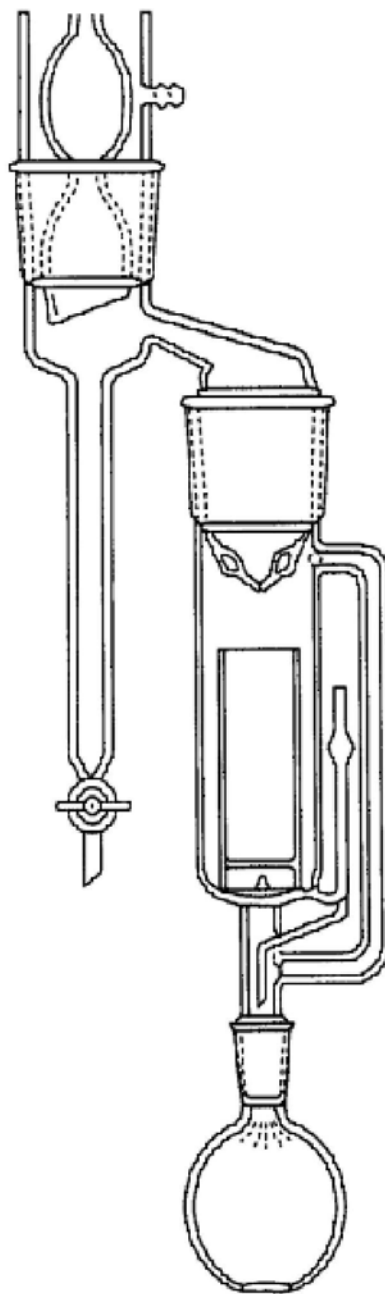

Figure 5 Soxhlet/Dean-Stark Extractor

24.0 Glossary

These definitions and purposes are specific to this Method but have been conformed to common usage to the extent possible.

24.1 Units of weight and measure

24.1.1 Symbols

EC	degrees Celsius
ΦL	microliter
Φm	micrometer
<	less than
>	greater than
%	percent

24.1.2 Alphabetical abbreviations

cm	centimeter
g	gram
h	hour
ID	inside diameter
in.	inch
L	liter
M	Molecular ion
m	mass or meter
mg	milligram
min	minute
mL	milliliter
mm	millimeter
m/z	mass-to-charge ratio
N	normal; gram molecular weight of solute divided by hydrogen equivalent of solute, per liter of solution
OD	outside diameter
pg	picogram
ppb	part-per-billion
ppm	part-per-million
ppq	part-per-quadrillion
ppt	part-per-trillion
psig	pounds-per-square inch gauge
v/v	volume per unit volume
w/v	weight per unit volume

25.0 Definitions and acronyms (in alphabetical order)

Analyte – A pesticide tested for by this Method. The analytes are listed in Table 1.

Calibration standard (CAL) – A solution prepared from a secondary standard and/or stock solution and used to calibrate the response of the HRGC/HRMS instrument.

Calibration verification standard (VER) – The mid-point calibration standard (CS-4) that is used to verify calibration. See Table 4.

CS-1, CS-2, CS-3, CS-4, CS-5, CS-6 – See Calibration standards and Table 4.

Field blank – An aliquot of reagent water or other reference matrix that is placed in a sample container in the field, and treated as a sample in all respects, including exposure to sampling site conditions, storage, preservation, and all analytical procedures. The purpose of the field blank is to determine if the field or sample transporting procedures and environments have contaminated the sample.

GC – Gas chromatograph or gas chromatography

GPC – Gel permeation chromatograph or gel permeation chromatography

HPLC – High performance liquid chromatograph or high performance liquid chromatography

HRGC – High resolution GC

HRMS – High resolution MS

Labeled injection internal standard – Labeled PCB52 is spiked into the concentrated extract immediately prior to injection of an aliquot of the extract into the HRGC/HRMS.

Internal standard – a labeled compound used as a reference for quantitation of other labeled compounds and for quantitation of native pesticides other than the pesticide of which it is a labeled analog. See Internal standard quantitation.

Internal standard quantitation – A means of determining the concentration of (1) a naturally occurring (native) compound by reference to a compound other than its labeled analog and (2) a labeled compound by reference to another labeled compound.

IPR – Initial precision and recovery; four aliquots of a reference matrix spiked with the analytes of interest and labeled compounds and analyzed to establish the ability of the laboratory to generate acceptable precision and recovery. An IPR is performed prior to the first time this Method is used and any time the Method or instrumentation is modified.

Isotope dilution quantitation – A means of determining a naturally occurring (native) compound by reference to the same compound in which one or more atoms has been isotopically enriched. In this Method, labeled are enriched with carbon-13 to produce ^{13}C -labeled analogs. The ^{13}C -labeled pesticides are spiked into each sample to allow identification and correction of the concentration of the native compounds in the analytical process.

K-D – Kuderna-Danish concentrator; a device used to concentrate the analytes in a solvent

Laboratory blank – See Method blank

Laboratory control sample (LCS) – See Ongoing precision and recovery standard (OPR)

Laboratory reagent blank – See Method blank

May – This action, activity, or procedural step is neither required nor prohibited.

May not – This action, activity, or procedural step is prohibited.

Method blank – An aliquot of reagent water that is treated exactly as a sample including exposure to all glassware, equipment, solvents, reagents, internal standards, and surrogates that are used with samples. The Method blank is used to determine if analytes or interferences are present in the laboratory environment, the reagents, or the apparatus.

Method detection limit (MDL) – The lowest concentration at which a pesticide can be detected under routine operating conditions (see 40 CFR 136, appendix B). MDLs are listed in Table 1.

Minimum level (ML) – The greater of a multiple of the MDL or the lowest calibration point (see 68 FR 11790, March 12, 2003.)

MS – Mass spectrometer or mass spectrometry

Must – This action, activity, or procedural step is required.

OPR – Ongoing precision and recovery standard (OPR); a method blank spiked with known quantities of analytes. The OPR is analyzed exactly like a sample. Its purpose is to assure that the results produced by the laboratory remain within the limits specified in this Method for precision and recovery.

Perfluorokerosene (PFK) – A mixture of compounds used to calibrate the exact m/z scale in the HRMS.

Preparation blank – See Method blank

Quality control check sample (QCS) – A sample containing all or a subset of the analytes at known concentrations. The QCS is obtained from a source external to the laboratory or is prepared from a source of standards different from the source of calibration standards. It is used to check laboratory performance with test materials prepared external to the normal preparation process.

Reagent water – water demonstrated to be free from the analytes of interest and potentially interfering substances at the method detection limit for the analyte.

Relative standard deviation (RSD) – The standard deviation times 100 divided by the mean. Also termed "coefficient of variation."

RF – Response factor. See Section 10.5

RR – Relative response. See Section 10.4

RSD – See relative standard deviation

SDS – Soxhlet/Dean-Stark extractor; an extraction device applied to the extraction of solid and semi-solid materials (Reference 3 and Figure 5).

Signal-to-noise ratio (S/N) – The height of the signal as measured from the mean (average) of the noise to the peak maximum divided by the width of the noise.

Should – Although this action, activity, or procedural step is suggested and not required, you may be asked why you changed or omitted this action, activity, or procedural step.

SICP – Selected ion current profile; the line described by the signal at an exact m/z.

SPE – Solid-phase extraction; an extraction technique in which an analyte is extracted from an aqueous sample by passage over or through a material capable of reversibly adsorbing the analyte. Also termed liquid-solid extraction.

Stock solution – A solution containing an analyte that is prepared using a reference material traceable to EPA, the National Institute of Science and Technology (NIST), or a source that will attest to the purity and authenticity of the reference material.

Unique GC resolution or uniquely resolved – Two adjacent chromatographic peaks in which the height of the valley is less than 10 percent of the height of the shorter peak (see Section 6.9.1.1.2).

VER – See Calibration verification.