



United States  
Environmental Protection  
Agency

GRI-947 0257.31  
EPA - 600/R-96-080n  
June 1996

---

# Research and Development

METHANE EMISSIONS FROM THE  
NATURAL GAS INDUSTRY  
Volume 14: Glycol Dehydrators

## Prepared for

Energy Information Administration (U. S. DOE)

## Prepared by

National Risk Management  
Research Laboratory  
Research Triangle Park, NC 27711

## FOREWORD

The U.S. Environmental Protection Agency is charged by Congress with protecting the Nation's land, air, and water resources. Under a mandate of national environmental laws, the Agency strives to formulate and implement actions leading to a compatible balance between human activities and the ability of natural systems to support and nurture life. To meet this mandate, EPA's research program is providing data and technical support for solving environmental problems today and building a science knowledge base necessary to manage our ecological resources wisely, understand how pollutants affect our health, and prevent or reduce environmental risks in the future.

The National Risk Management Research Laboratory is the Agency's center for investigation of technological and management approaches for reducing risks from threats to human health and the environment. The focus of the Laboratory's research program is on methods for the prevention and control of pollution to air, land, water, and subsurface resources; protection of water quality in public water systems; remediation of contaminated sites and groundwater; and prevention and control of indoor air pollution. The goal of this research effort is to catalyze development and implementation of innovative, cost-effective environmental technologies; develop scientific and engineering information needed by EPA to support regulatory and policy decisions; and provide technical support and information transfer to ensure effective implementation of environmental regulations and strategies.

This publication has been produced as part of the Laboratory's strategic long-term research plan. It is published and made available by EPA's Office of Research and Development to assist the user community and to link researchers with their clients.

E. Timothy Oppelt, Director  
National Risk Management Research Laboratory

## EPA REVIEW NOTICE

This report has been peer and administratively reviewed by the U.S. Environmental Protection Agency, and approved for publication. Mention of trade names or commercial products does not constitute endorsement or recommendation for use.

This document is available to the public through the National Technical Information Service, Springfield, Virginia 22161.

GRI-94/025731

EPA-600/R-96-080n

June 1996

**METHANE EMISSIONS FROM  
THE NATURAL GAS INDUSTRY,  
VOLUME 14: GLYCOL DEHYDRATORS**

**FINAL REPORT**

Prepared by:

Duane Myers

Radian International LLC  
8501 N. Mopac Blvd.  
P.O. Box 201088  
Austin, TX 78720-1088

DCN: 95-263-081-15

For

GRI Project Manager: Robert A. Lott  
GAS RESEARCH INSTITUTE  
Contract No. 5091-251-2171  
8600 West Bryn Mawr Ave.  
Chicago, IL 60631

and

EPA Project Manager: David A. Kirchgessner  
U.S. ENVIRONMENTAL PROTECTION AGENCY  
Contract No. 68-D1-0031  
National Risk Management Research Laboratory  
Research Triangle Park, NC 27711

## DISCLAIMER

**LEGAL NOTICE:** This report was prepared by Radian International LLC as an account of work sponsored by Gas Research Institute (GRI) and the U.S. Environmental Protection Agency (EPA). Neither EPA, GRI, members of GRI, nor any person acting on behalf of either:

- a. Makes any warranty or representation, express or implied, with respect to the accuracy, completeness, or usefulness of the information contained in this report, or that the use of any apparatus, method, or process disclosed in this report may not infringe privately owned rights; or
- b. Assumes any liability with respect to the use of, or for damages resulting from the use of, any information, apparatus, method, or process disclosed in this report.

**NOTE:** EPA's Office of Research and Development quality assurance/quality control (QA/QC) requirements are applicable to some of the count data generated by this project. Emission data and additional count data are from industry or literature sources, and are not subject to EPA/ORD's QA/QC policies. In all cases, data and results were reviewed by the panel of experts listed in Appendix D of Volume 2.

## RESEARCH SUMMARY

Title	Methane Emissions from the Natural Gas Industry, Volume 14: Glycol Dehydrators Final Report
Contractor	Radian International LLC  GRI Contract Number 5091-251-2171 EPA Contract Number 68-D1-0031
Principal Investigator	Duane B. Myers
Report Period	March 1991 - June 1996 Final Report
Objective	This report describes a study to quantify the annual methane emissions from glycol dehydrators and acid gas recovery units (AGRs), which are significant sources of methane emissions within the gas industry.
Technical Perspective	<p>The increased use of natural gas has been suggested as a strategy for reducing the potential for global warming. During combustion, natural gas generates less carbon dioxide (CO<sub>2</sub>) per unit of energy produced than either coal or oil. On the basis of the amount of CO<sub>2</sub> emitted, the potential for global warming could be reduced by substituting natural gas for coal or oil. However, since natural gas is primarily methane, a potent greenhouse gas, losses of natural gas during production, processing, transmission, and distribution could reduce the inherent advantage of its lower CO<sub>2</sub> emissions.</p> <p>To investigate this, Gas Research Institute (GRI) and the U.S. Environmental Protection Agency's Office of Research and Development (EPA/ORD) cofunded a major study to quantify methane emissions from U.S. natural gas operations for the 1992 base year. The results of this study can be used to construct global methane budgets and to determine the relative impact on global warming of natural gas versus coal and oil.</p>
Results	The annual emissions rates for glycol dehydrators for each industry segment are as follows: production, $3.42 \pm 192\%$ Bscf; gas processing, $1.05 \pm 208\%$ Bscf; transmission, $0.10 \pm 392\%$ Bscf, and storage, $0.23 \pm 167\%$ Bscf. AGR methane emissions are $0.82 \pm 109\%$ Bscf.

Based on data from the entire program, methane emissions from natural gas operations are estimated to be  $314 \pm 105$  Bscf for the 1992 base year. This is about  $1.4 \pm 0.5\%$  of gross natural gas production. The overall project also showed that the percentage of methane emitted for an incremental increase in natural gas sales would be significantly lower than the baseline case.

The program reached its accuracy goal and provides an accurate estimate of methane emissions that can be used to construct U.S. methane inventories and analyze fuel switching strategies.

#### Technical Approach

Glycol dehydrators are used to remove water from natural gas streams. A lean (low water content) glycol stream is contacted with the wet natural gas and the glycol absorbs most of the water. The glycol also absorbs small amounts of methane and other natural gas constituents which may then be emitted to the atmosphere when the glycol is regenerated. AGRs work in much the same way as glycol dehydrators. A lean (low acid gas content) amine is contacted with natural gas containing carbon dioxide and/or hydrogen sulfide. The amine preferentially absorbs the carbon dioxide and hydrogen sulfide but also absorbs some methane, which may then be emitted to the atmosphere.

The techniques used to determine methane emissions were developed to be representative of annual emissions from the natural gas industry. However, it is impractical to measure every source continuously for a year. Therefore, emission rates for glycol dehydrators and AGRs were determined by developing annual emission factors for typical units in each industry segment and extrapolating these data based on activity factors to develop a national estimate, where the national emission rate is the product of the emission factor and activity factor.

Emission factors were developed by using process simulation software to model the glycol dehydrator and AGR process operations. Information from site visits and other research programs was used to develop the characteristics of representative units used in the process modeling. An emission factor was developed for glycol dehydrators that reported the amount of methane emitted per unit of natural gas throughput and for AGRs that reported the amount of methane emitted annually for a typical unit.

The development of activity factors for each industry segment are presented in a separate report. In general, the gas throughput for each industry segment was determined from surveys conducted across the entire industry.

Project  
Implications

For the 1992 base year the annual methane emissions estimate for the U.S. natural gas industry is 314 Bscf  $\pm$  105 Bscf ( $\pm$  33%). This is equivalent to 1.4%  $\pm$  0.5% of gross natural gas production. Results from this program were used to compare greenhouse gas emissions from the fuel cycle for natural gas, oil, and coal using the global warming potentials (GWPs) recently published by the Intergovernmental Panel on Climate Change (IPCC). The analysis showed that natural gas contributes less to potential global warming than coal or oil, which supports the fuel switching strategy suggested by IPCC and others.

In addition, results from this study are being used by the natural gas industry to reduce operating costs while reducing emissions. Some companies are also participating in the Natural Gas-Star program, a voluntary program sponsored by EPA's Office of Air and Radiation in cooperation with the American Gas Association to implement cost-effective emission reductions and to report reductions to the EPA. Since this program was begun after the 1992 baseline year, any reductions in methane emissions from this program are not reflected in this study's total emissions.

Robert A. Lott  
Senior Project Manager, Environment and Safety

## TABLE OF CONTENTS

	Page
1.0 SUMMARY .....	1
2.0 INTRODUCTION .....	2
3.0 DESCRIPTION OF GLYCOL DEHYDRATORS IN THE NATURAL GAS INDUSTRY .....	3
3.1 Operation Overview .....	3
3.2 Field Gas Production .....	6
3.3 Gas Processing Plants .....	6
3.4 Gas Transmission .....	7
3.5 Gas Storage .....	7
4.0 ACTIVITY FACTORS .....	8
4.1 Industry Gas Segment Gas Throughput and Dehydrator Counts .....	8
4.1.1 Production and Transmission .....	9
4.1.2 Gas Processing .....	10
4.1.3 Storage .....	10
4.2 Other Dehydrator Characteristics .....	10
4.2.1 Flash Tanks .....	10
4.2.2 Stripping Gas and Vapor Recovery .....	11
4.3 AGR Activity Factors .....	12
5.0 EMISSION FACTORS .....	13
5.1 Test Description .....	14
5.2 Results of Emission Estimates .....	16
5.3 Calculated Emission Factors .....	18
5.4 AGR Emission Factor .....	23
5.5 Emission Factor Summary .....	23
6.0 ANNUAL METHANE EMISSIONS .....	24
7.0 REFERENCES .....	25
APPENDIX A - Emission Source Sheets .....	A-1



## LIST OF FIGURES

	<b>Page</b>
3-1 Block Process Flow Diagram of a Typical Glycol Dehydrator . . . . .	4
5-1 Methane Emissions - Glycol Regenerator Effect on Methane Composition . . . . .	19
5-2 Methane Emissions - Glycol Regenerator Effect on Glycol Recirculation Rate . . . . .	20
5-3 Methane Emissions - Glycol Regenerator Effect on Flash Tank Pressure . . . . .	21

## LIST OF TABLES

	<b>Page</b>
4-1 Estimated Annual Dehydrator Throughput . . . . .	9
4-2 Activity Factors for Flash Tank Populations . . . . .	11
4-3 Dehydrators Using Stripping Gas or Vapor Recovery . . . . .	11
5-1 Test Matrix for Studying the Effect of Process Parameters on Methane Emissions from Glycol Regenerators . . . . .	15
5-2 Effects of Process Parameters on Methane Emissions from Glycol Regenerators . . . . .	17
5-3 Summary of Glycol Dehydrator and AGR Emission Factors . . . . .	23

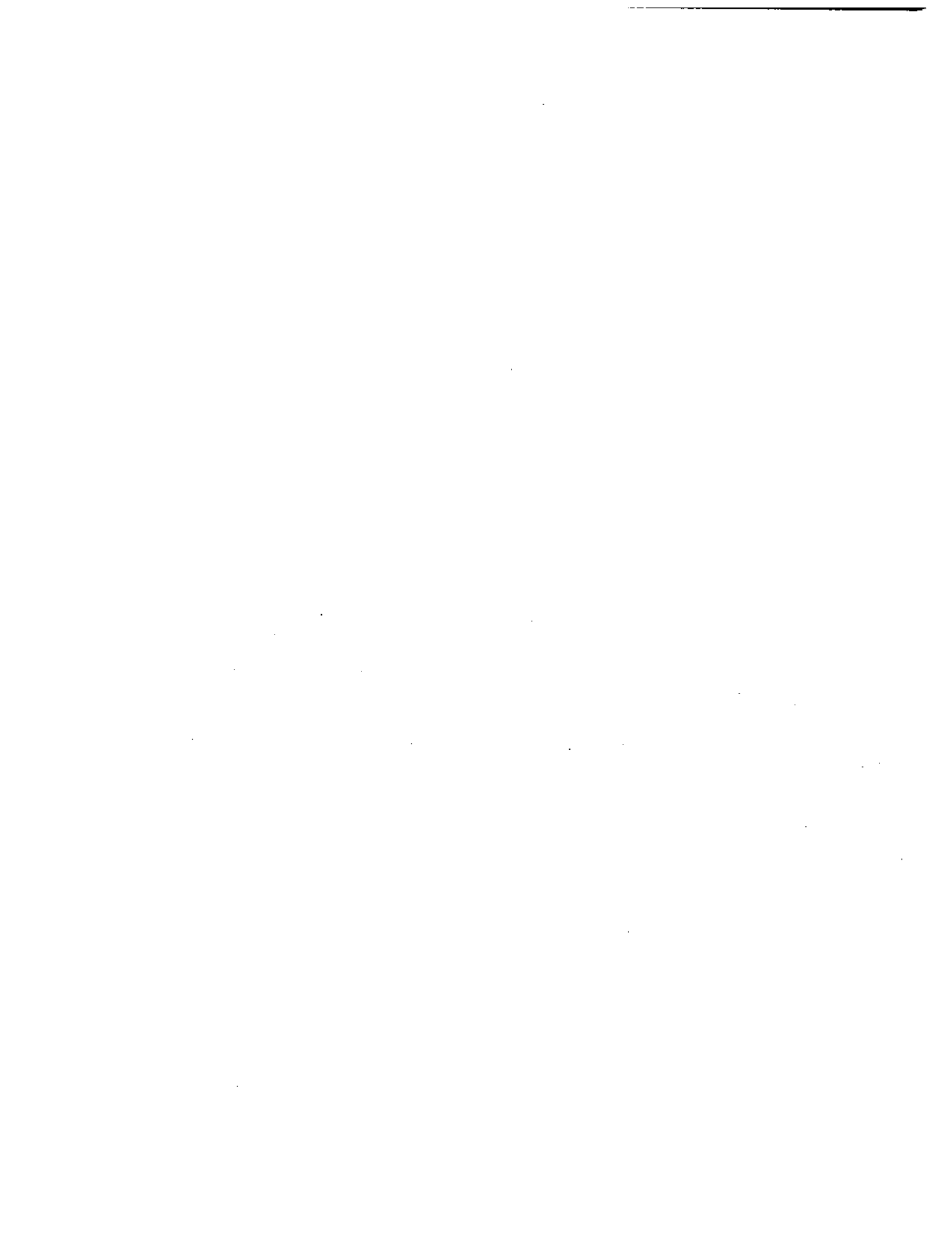

## 1.0 SUMMARY

This report is one of several volumes that provide background information supporting the Gas Research Institute and U.S. Environmental Protection Agency Office of Research and Development (GRI-EPA/ORD) methane emissions project. The objective of this comprehensive program is to quantify the methane emissions from the gas industry for the 1992 base year to within  $\pm 0.5\%$  of natural gas production starting at the wellhead and ending immediately downstream of the customer's meter.

This report describes the characteristics of glycol dehydrators that affect methane emissions and summarizes the basis of the national estimate of emissions from this source. Also included in this category are methane emissions from acid gas removal (AGR) units in gas processing plants, since AGRs are similar to glycol dehydrators in design and characteristics that affect emissions.

The annual emissions for glycol dehydrators for each industry segment are as follows: production,  $3.42 \pm 192\%$  Bscf; gas processing,  $1.05 \pm 208\%$  Bscf; transmission,  $0.10 \pm 392\%$  Bscf; and storage,  $0.23 \pm 167\%$  Bscf. AGR methane emissions are  $0.82 \pm 109\%$  Bscf.

## 2.0 INTRODUCTION

Dehydrator activity factor<sup>a</sup> demographics were developed on the basis of data from several surveys. The percentage of glycol dehydrators (as opposed to molecular sieve or other types) was established to be about 95% of the total population of 41,700, for a count of 39,615 glycol dehydrators nationwide.<sup>1</sup> Initially, the count of dehydrators in each industry segment was used as the activity factor. At the suggestion of the Industry Working Group (industry members who serve as project advisors), the activity factor basis was changed to dehydrator gas throughput. The final activity factors used by this project are documented in Section 4. An emission factor<sup>b</sup> was developed using information from field measurements, as well as a computer simulation using ASPEN/SP<sup>®</sup> software. The emission factor results are reported in Section 5. The estimated annual methane emissions from dehydrators from each industry segment are given in Section 6.

---

<sup>a</sup>An *activity factor* is a count of the total industry population of a particular type of source. It is the total number of sources in the entire target population or source category.

<sup>b</sup>An *emission factor* for a source category is a measure of the average annual emission per source. It is the summation of all measured or calculated emissions from sampled sources divided by the total number of sources in the category that were sampled.

### 3.0 DESCRIPTION OF GLYCOL DEHYDRATORS IN THE NATURAL GAS INDUSTRY

This section describes the glycol dehydrators found in the natural gas industry, as well as differences in installations in various segments of the industry.

#### 3.1 Operation Overview

Dehydrators are designed to remove water from the natural gas vapor stream, reducing corrosion and preventing the formation of hydrates, which are solid clathrate compounds that can cause flow restrictions and plugging in valves and even pipelines. There are several types of dehydrators, ranging from solid molecular sieve adsorption beds to liquid absorption dehydrators.

Glycol dehydrators are liquid absorption units that absorb water in a liquid glycol stream. Approximately 95% of glycol dehydrators use triethylene glycol (TEG), with most of the remainder using ethylene glycol (EG). (TEG and EG have very different properties for water removal but are similar for methane emissions.) The dehydrators usually consist of two primary sections: the absorber and the regenerator. Figure 3-1 shows a typical block flow diagram for a glycol dehydrator. The lean liquid glycol usually flows downward in an absorption tower, counter-current to the natural gas. The glycol absorbs most of the water from the natural gas, but it also absorbs other materials present in the gas stream. The dried natural gas exits the top of the tower. The water-rich glycol leaves the bottom of the tower and flows to the regenerator. The regenerator heats the glycol to drive off water vapor, and the water vapor is usually vented directly to the atmosphere through the regenerator vent stack. The lean glycol is then returned to the absorber. Glycol has a high affinity for water and a relatively low affinity for non-aromatic hydrocarbons, which makes it a very good absorbent fluid for drying natural gas. However, the glycol does absorb small amounts of methane and other hydrocarbons from the natural gas. The hydrocarbons are released to the atmosphere, along with the water vapor from the regenerator vent.

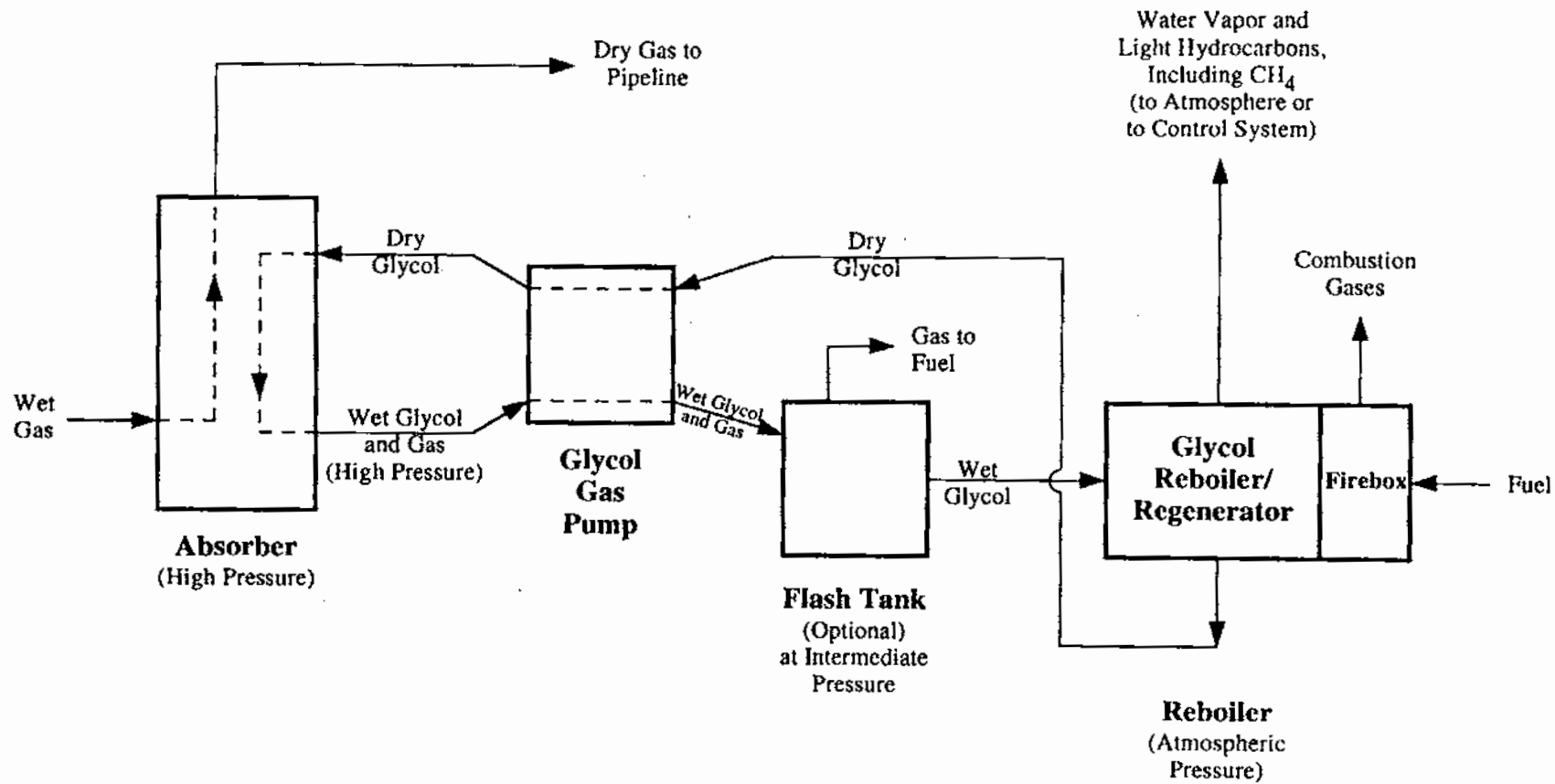

Figure 3-1. Block Process Flow Diagram of a Typical Glycol Dehydrator

All glycol dehydrators have pumps to circulate the glycol. Some pumps in the field are gas-assisted pumps that greatly increase the methane emissions from the glycol unit. These pumps are powered by upstream (wet) line gas, and the spent pumping gas is dumped into the rich glycol stream and flashed off in the regenerator. For the purposes of this study, the gas-assisted pumps were considered separate sources, even though the methane they use is vented through the regenerator. Gas-assisted pumps are discussed in a separate report,<sup>2</sup> and are not included in this analysis of dehydrator emissions.

Some glycol dehydrators have additional equipment. Two common additions are flash tanks and regenerator vent emissions control equipment. The flash tank is placed in the rich glycol loop between the absorber and the regenerator. The glycol line pressure is dropped in the flash tank, causing most of the light hydrocarbons to flash into the vapor phase. The flash gas is usually routed to the regenerator burner as fuel. The methane emissions from the regenerator vent can be significantly reduced by using a flash tank.

Regenerator vent control devices have been installed on some units to reduce emissions of benzene, toluene, ethylbenzene, and xylenes (BTEX) and volatile organic compounds (VOC) to the atmosphere. These compounds are absorbed from the gas stream and driven off with the water in the regenerator vent. Control devices usually condense the water and hydrocarbon (containing BTEX and heavier VOC), then decant the hydrocarbon for sale and the water for disposal. The methane in the vent is not condensed and is usually vented, but it can be flared or used as fuel in the regenerator burner. Many glycol dehydrator operators have installed some type of vapor recovery system on the regenerator still vent, although the controls are primarily targeted for BTEX and not methane control.

Some dehydrators use stripping gas in the regenerator. Gas from the absorber outlet or from the flash tank is introduced into the regenerator to help strip the water and other absorbed compounds out of the glycol by increasing the vapor flow rate in the reboiler still. Methane in the stripping gas passes directly through the regenerator into the atmospheric vent.

### **3.2 Field Gas Production**

Field production removes water in two steps. First, a surface separator vessel removes the liquid phases (free water and oil) from the natural gas. This liquid phase water is then separated from the oil to preserve the purity of the oil. The gas from the top of the separator often remains saturated with absorbed water and is treated again by field dehydrators to dry the gas to low parts per million (ppm) levels of water to prevent corrosion and plugging of the gathering lines.

Many field dehydrators are small glycol units with very little instrumentation and without flash tanks. Comparatively few production units have regenerator vent emission controls, although more operators are installing controls as new environmental regulations take effect. Many production units have glycol pumps driven by gas-pressure letdown. Most production units use TEG as the absorption fluid.

### **3.3 Gas Processing Plants**

Dehydration is fundamental to gas processing plants, especially those that use refrigerated or cryogenic liquids recovery methods. However, if water is present, the cold temperatures promote the formation of hydrates. Therefore, gas processing plants use molecular sieve beds or glycol dehydrators upstream of the liquids recovery section.

Some plants do not use a typical dehydrator configuration with an absorber. Rather, they inject the glycol directly into the gas stream and allow contact to occur in the pipeline. The entire stream then passes through a separator, where the dry gas, rich liquid glycol, and condensed hydrocarbon phase are separated. The rich glycol passes to a regenerator and is recycled to the injection point. Most injection-type dehydrators use ethylene glycol (EG) as the absorbing liquid.



Plants that use a typical absorber tower may or may not have a flash tank or vent recovery equipment. Some plants may route the vent gases to a plant flare system. Most plant glycol pumps are powered by electricity instead of gas.

AGR units have the same basic equipment as a glycol dehydrator: an absorber tower, a pump to circulate the liquid, and a reboiler to regenerate the absorber liquid. AGRs typically use an aqueous solution of one of a variety of amine compounds (e.g., monoethanolamine, diethanolamine) to remove carbon dioxide and hydrogen sulfide from natural gas.

### 3.4 Gas Transmission

Production gas is typically dry when it enters a gas transmission system, having passed through field production and gas processing plant dehydrators. There usually is no need to dry gas being transported through the pipeline, although some pipeline gas is dehydrated.

### 3.5 Gas Storage

Gas stored underground for distribution during peak usage may pick up water and need to be dehydrated. Dehydrators used to dry stored gas are typically the same design as production field dehydrators but tend to be much larger and better maintained. These large storage dehydrators are more likely to include flash tanks and some type of vent recovery system than are production field dehydrators.

## 4.0 ACTIVITY FACTORS

This section briefly summarizes activity factor calculations for dehydrators and AGRs. A more detailed discussion is presented in the Volume 5 on activity factors.<sup>3</sup> The results account for the 90% confidence limits calculated for each activity factor.

The overall activity factor for each industry segment is the total segment gas throughput. The overall activity factor is multiplied by the emission factor (given in Section 4) to obtain the annual methane emissions.

Other characteristics of glycol dehydrators are used in the calculations overall activity factor and emission factor. These include:

- Number of dehydrators;
- Dehydrator throughput;
- Fraction of dehydrators with flash tanks;
- Fraction of dehydrators with stripping gas; and
- Fraction of dehydrators with vent vapor recovery.

More specific information for each characteristic is given in the following sections.

### 4.1 Industry Segment Gas Throughput and Dehydrator Counts

The overall activity factors are the amount of gas dehydrated annually in each industry segment. The estimated annual glycol dehydrator throughputs for each industry segment are listed in Table 4-1.

**TABLE 4-1. ESTIMATED ANNUAL DEHYDRATOR THROUGHPUT**

<b>Segment</b>	<b>Gas Throughput (MMscf/year)</b>
Production	$12.4 \times 10^6 \pm 61.9\%$
Processing	$8.63 \times 10^6 \pm 22.4\%$
Transmission	$1.09 \times 10^6 \pm 144\%$
Storage	$2.00 \times 10^6 \pm 25.0\%$
Total Gas Industry	$24.12 \times 10^6 \pm 33.5\%$

The total industry segment throughputs were calculated in several different ways be discussed below.

#### 4.1.1 Production and Transmission

The activity factors for production and transmission were calculated using the equation:

$$AF = P \times CP \times CU \times 365 \text{ days/year} \quad (1)$$

P = Population of dehydrators in each industry segment (see Appendix A)  
 Production:  $37,824 \pm 21.1\%$   
 Transmission:  $201 \pm 119\%$

CP = Average gas throughput capacity per dehydrator<sup>1</sup> (MMscfd)  
 Production:  $2.00 \pm 28.1\%$   
 Transmission:  $14.8 \pm 29.5\%$

CU = Capacity utilization--ratio of actual gas throughput to capacity (see Appendix A)  
 Production:  $0.45 \pm 32\%$   
 Transmission:  $1.00 \pm 0\%$

#### **4.1.2 Gas Processing**

The gas processing activity factor was calculated from the reported gas plant throughput and process type from the *Oil and Gas Journal* annual survey of gas plants.<sup>4</sup> It was assumed that all gas plants using a refrigerated process use glycol dehydration and gas plants using a cryogenic process use some type of dry-bed dehydration (which has negligible methane emissions). The fraction of gas processed by glycol dehydrators was determined to be 0.495 (or 8.63 Tscf/year) of a total of 17.44 Tscf/year.

#### **4.1.3 Storage**

The storage activity factor was calculated from the amount of gas removed from underground storage annually (2.4 Tscf) as reported in *A.G.A. Gas Facts*.<sup>5</sup> It was estimated that most gas removed from underground storage is dehydrated by glycol; 2.0 Tscf/year  $\pm$  25% was used as the activity factor.

### **4.2 Other Dehydrator Characteristics**

Fractions of dehydrator populations with flash tanks, stripping gas, and vapor recovery systems were also used in the emission calculations. These characteristics and the field data can be found in the Activity Factor report.<sup>3</sup>

#### **4.2.1 Flash Tanks**

The fraction of glycol dehydrators with flash tanks was estimated by combining the results of site surveys with the results of a survey conducted by the Texas Mid-Continent Oil and Gas Association (TMOGA).<sup>6</sup> The fractions used in the emission factor calculations are listed in Table 3-2.

**TABLE 4-2. ACTIVITY FACTORS FOR FLASH TANK POPULATIONS**

<b>Segment</b>	<b>Fraction of Dehydrators with Flash Tanks</b>
Production	0.265 ± 8.35%
Processing	0.667 ± 10.1%
Transmission	0.669 ± 9.70%
Storage	0.520 ± 33.6%

#### 4.2.2 Stripping Gas and Vapor Recovery

The fractions of glycol dehydrators that use stripping gas in the regenerator or have a vapor recovery system that eliminates methane emissions were estimated from the results of site surveys. The fractions used in the emission factor calculations are listed in Table 4-3.

**TABLE 4-3. DEHYDRATORS USING STRIPPING GAS OR VAPOR RECOVERY**

<b>Segment</b>	<b>Fraction of Dehydrators with Active Stripping Gas</b>	<b>Fraction of Dehydrators with Vapor Recovery that Consumes Methane</b>
Production	0.0047 ± 116%	0.012 ± 73.1%
Processing	0.111 ± 186%	0.10 ± 0% <sup>a</sup>
Transmission	0.074 ± 118%	0.148 ± 80.3%
Transmission	0.080 ± 118%	0.160 ± 80.8%

<sup>a</sup>For the emissions calculations it was assumed that 10% of gas processing dehydrators have vent controls, although none were observed during the site visits.

### 4.3 AGR Activity Factors

The number of amine-based AGRs in gas processing service has been reported to be 371 in a report for GRI by Purvin & Gertz, Inc.<sup>7</sup> Confidence limits were not given in the report; therefore, they were assumed to be  $\pm 20\%$ . Assuming an average AGR gas throughput of  $36.5 \text{ MMscfd} \pm 20\%$  (equal to a gas processing dehydrator throughput), the AGR activity factor is  $1.354 \times 10^4 \text{ MMscf/year}$ . Another survey reported that 18% of the AGR reboilers vent directly to the atmosphere and would be a source of methane emissions.<sup>8</sup>

## 5.0 EMISSION FACTORS

Estimates of methane emissions from dehydrators were developed using estimates from computer simulation and some field data measurements. ASPEN/SP® (from Simulation Sciences, Inc.) process simulation software was used for several case studies.<sup>9</sup>

Glycol dehydrators have numerous characteristics that affect methane emissions from the regenerator vent. Using a computer simulation model and varying the key dehydrator parameters, the following characteristics of glycol dehydrators that affect emissions were examined:

- Overall unit
  - Size of the unit (MMscf of gas processed/day)
  - Glycol type
  - Glycol circulation rate
  - Lean glycol percent water
  - Regenerator reboiler temperature
- Inlet gas information
  - Methane composition
  - Temperature
  - Pressure
- Flash tank information
  - Use of a flash tank
  - Pressure
  - Temperature
- Stripping gas use
- Vent recovery/control equipment

The size of the unit affects how much methane is contacted, how much glycol is circulated, and therefore how much methane is absorbed. Several types of glycol can be

used, but TEG and EG are the most common. Each of these glycols has a different affinity for methane. The glycol circulation rate affects the contact time, and therefore how much methane is absorbed by the glycol. The lean glycol water concentration is a measure of how well the regenerator has restored the glycol before it returns to the absorber. A high concentration of water in the lean glycol reduces its ability to absorb water from the gas stream.

The inlet methane composition, gas temperature, and gas pressure affect the methane partial pressure in the absorber. This changes the amount of methane relative to other materials that can be absorbed by the glycol.

Many characteristics that were judged to have a negligible effect on the amount of methane absorbed were eliminated from consideration. Examples are the number of trays in the reboiler still, the inlet BTEX composition, and the inlet water composition.

## 5.1 Test Description

A matrix approach was used to study the effect of process parameters on methane emissions from a glycol regenerator. The process parameters include:

- Methane composition;
- Glycol circulation rate;
- Lean glycol water content;
- Flash tank temperature and pressure;
- Gas flow rate; and
- Gas temperature and pressure.

The test matrix is shown in Table 5-1.



**TABLE 5-1. TEST MATRIX FOR STUDYING THE EFFECT OF PROCESS PARAMETERS ON METHANE EMISSIONS FROM GLYCOL REGENERATORS**

Parameter	Very Low Value	Low Value	Medium Low Value	Base Value	Medium High Value	High Value	Very High Value	Supplemental Condition
Methane Composition (vol%)		85	87.5	90	92.5	95		
Glycol Circulation Rate (gph)		4.75	7.14	9.48	11.88	14.28		
Lean Glycol (% water)		0.5		1		1.5		
Flash Tank Pressure (psig)	15	30	45	60	75	90	120	No tank
Flash Tank Temperature (°F)		70		110		150		
Gas Flow Rate (MMscfd)		0.9		1		1.1		10 <sup>a</sup>
Gas Temperature (°F)		90		95		100		
Gas Pressure (psig)		600		800		1000		

<sup>a</sup> Glycol circulation rate is also increased by a factor of ten.

Input information for a base case dehydrator was chosen to represent Radian's best estimate of average dehydrator parameters based on the company's experience with permitting dehydrators and performing dehydrator studies for GRI and other private clients.

Initially, the base case was run to determine the emissions and to establish the number of theoretical stages for the glycol dehydrator. (The number of theoretical stages for a dehydrator is the number of absorber trays, with the gas and glycol at equilibrium, required to dry the gas to pipeline specification.) Then, low and high values were studied for each parameter. During the evaluation of one parameter, the other process parameters were kept at the base case values. A few supplemental cases were also studied.

After running the initial tests, the matrix was expanded for the parameters that showed the most variability. More tests were performed on the methane composition, glycol recirculation rate, and flash tank pressure. A run was also performed at a gas flow rate ten times the base case value. The glycol recirculation rate was correspondingly increased by a factor of ten. The emission rate for this case was found to be exactly one order of magnitude larger than the base case (0.0837 to 0.837 tons/yr), which indicates that the emission rate is linear with the flow rate, assuming that the glycol-to-gas ratio remains constant.

## **5.2 Results of Emission Estimates**

Table 5-2 presents the results of the emission estimates generated from the ASPEN/SP® model runs.<sup>9</sup> The glycol circulation rate remained proportional to the gas flow rate to maintain a constant glycol-to-gas ratio. Emission rate was found to be directly, linearly proportional to the gas flow rate if the glycol-to-gas ratio was held constant. The other variables also produced nearly linear relations.

**TABLE 5-2. EFFECTS OF PROCESS PARAMETERS ON METHANE EMISSIONS FROM GLYCOL REGENERATORS**

Parameter	Very Low Value	Low Value	Medium Low Value	Base Value	Medium High Value	High Value	Very High Value	Supplemental Condition
Methane Composition (vol%) Methane Emissions (tons/yr)		85 0.0701	87.5 0.0767	90 0.0837	92.5 0.0911	95 0.0999		
Glycol Circulation Rate (gph) Methane Emissions (tons/yr)		4.75 0.0419 <sup>a</sup>	7.14 0.0626	9.48 0.0837	11.88 0.104	14.28 0.125		
Lean Glycol (% water) Methane Emissions (tons/yr)		0.5 0.0841		1 0.0837		1.5 0.0832		
Flash Tank Pressure (psig) Methane Emissions (tons/yr)	15 0.0261	30 0.0442	45 0.0635	60 0.0837	75 0.104	90 0.125	120 0.168	No tank 1.12
Flash Tank Temperature (°F) Methane Emissions (tons/yr)		70 0.092		110 0.0837		150 0.0753		
Gas Flow Rate (MMscfd) Methane Emissions (tons/yr)		0.9 0.0837		1 0.0837		1.1 0.0837		10 <sup>b</sup> 0.837
Gas Temperature (°F) Methane Emissions (tons/yr)		90 0.0832		95 0.0837		100 0.0841		
Gas Pressure (psig) Methane Emissions (tons/yr)		600 0.0837		800 0.0837		1000 0.0837		

<sup>a</sup> Results not valid since the dry gas water content is greater than 7 lb H<sub>2</sub>O/MMscf.

<sup>b</sup> Glycol circulation rate is also increased by a factor of ten.

Number of absorber trays is fixed at 1.48.

Figures 5-1, 5-2, and 5-3 show the relation of methane composition, glycol circulation rate, and flash tank pressure on methane emissions. The single largest effect on the total emission rate was the presence or absence of a flash tank. A flash tank can reduce methane emissions by a factor of ten. One parameter not modeled was the addition of stripping gas. When stripping gas is added to the regenerator, all of it should exit as exhaust through the regenerator vent. This parameter has a major effect on dehydrator methane emissions.

### 5.3 Calculated Emission Factors

The variables accounted for in the emission factor calculations were presence of a flash tank, use of stripping gas, presence of a vapor recovery device on the still vent, and dehydrator gas throughput. Based on field observations from other GRI programs and on input from industry advisors, a dehydrator capacity utilization factor and glycol overcirculation factor were included.

These data were used to produce a national emission factor estimate for the average dehydrator in each industry segment using the average dehydrator capacity for each segment. Emission factors were derived for dehydrators in the production, gas processing, and transmission and transmission segments by the same basic method.

A thermodynamic computer simulation was used to determine the most important variables affecting emissions from dehydrators. The important variables are gas throughput, existence of a flash tank, existence of stripping gas, existence of a gas-driven glycol pump, and existence of vent controls routed to a burner. Other variables (e.g., reboiler temperature) were determined to be relatively unimportant from an emissions standpoint.

Throughput, since its effect is linear, is handled by establishing an emission rate per unit of gas throughput for all dehydrators. Emission rates per unit of throughput are

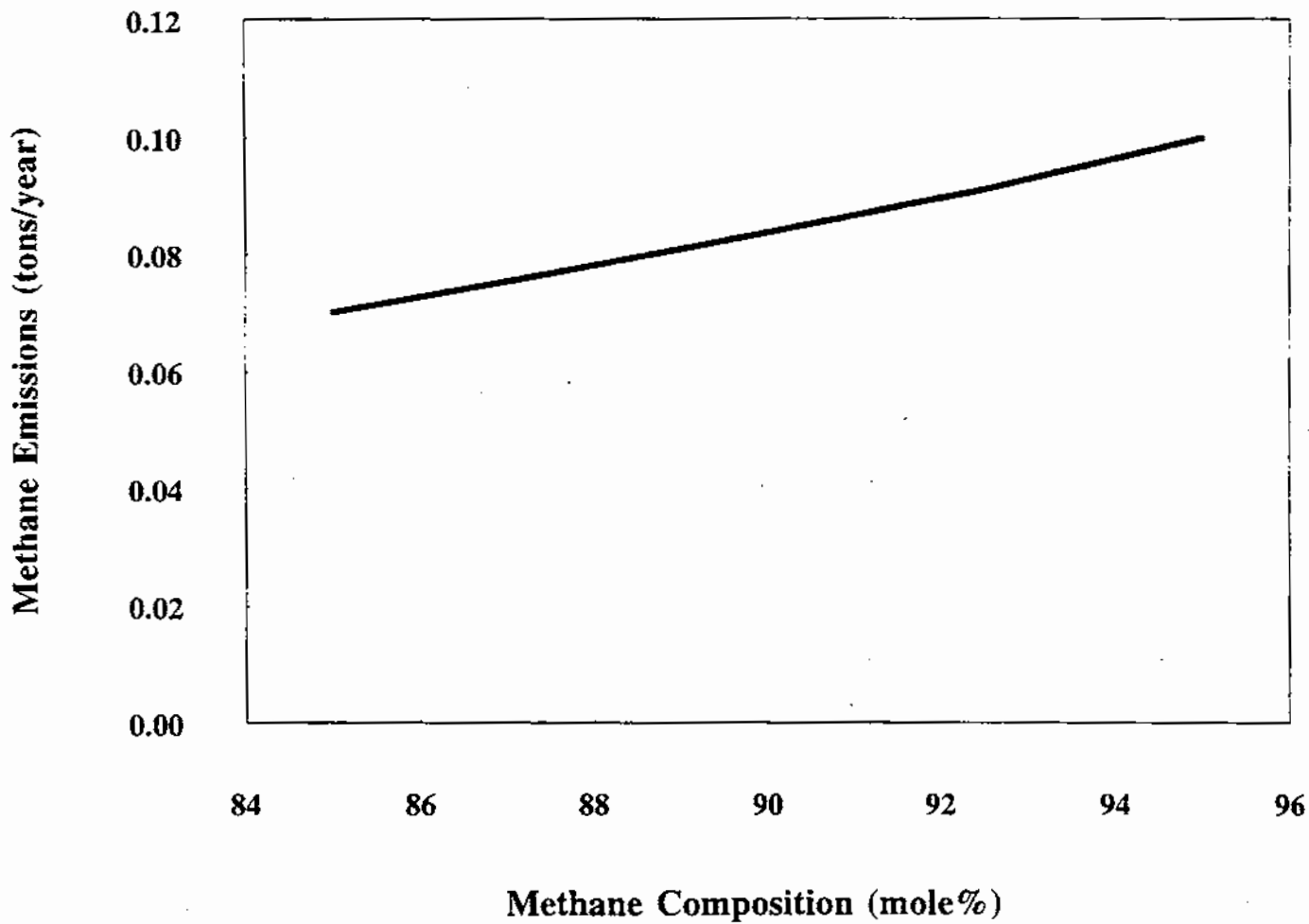

Figure 5-1. Methane Emissions - Glycol Regenerator Effect on Methane Composition

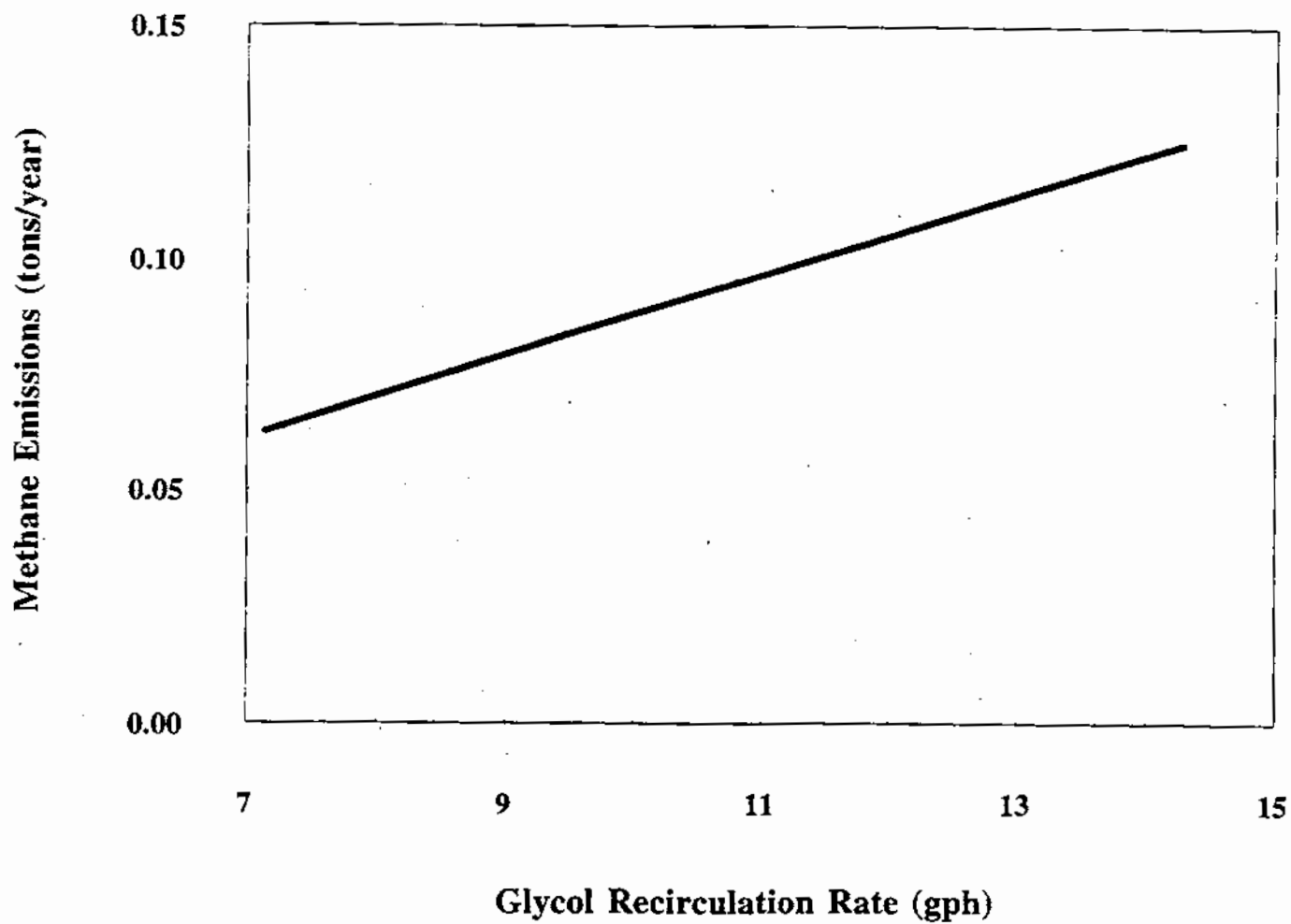

Figure 5-2. Methane Emissions - Glycol Regenerator Effect on Glycol Recirculation Rate

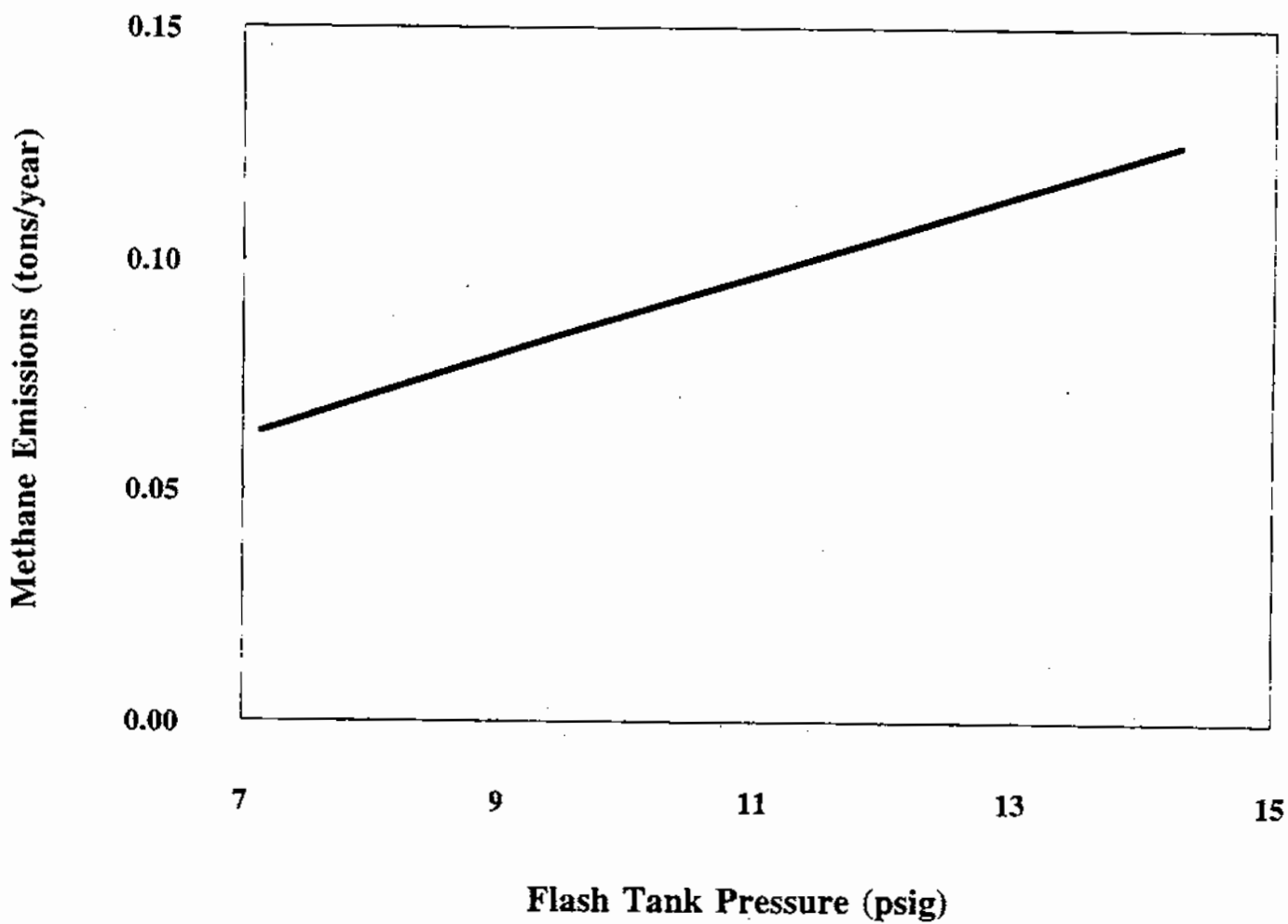

Figure 5-3. Methane Emissions - Glycol Regenerator Effect on Flash Tank Pressure

then established for the other important emission-affecting characteristics. Gas-assisted pumps are ignored here and handled in a separate source analysis.<sup>2</sup> The stripping gas rate was determined from observations at one site from the GRI Glycol Dehydrator Sampling and Analytical Program.<sup>10</sup> The emission factor is then:

$$EF = [ (F_{FT} \times EF_{FT}) + (F_{NT} \times EF_{NT}) + (F_{SG} \times EF_{SG}) ] \times F_{NVC} \times OC \quad (2)$$

$F_{FT}$	=	Fraction of the population WITH flash tanks
		Production: 0.265 ± 8.35%
		Gas processing: 0.667 ± 10.1%
		Transmission: 0.669 ± 9.70%
		Storage: 0.520 ± 33.6%
$F_{NT}$	=	Fraction of the population WITHOUT flash tanks
		Production: 0.735 ± 2.99%
		Gas processing: 0.333 ± 20.1%
		Transmission: 0.331 ± 19.6%
		Storage: 0.480 ± 36.3%
$F_{SG}$	=	Fraction of the population WITH stripping gas
		Production: 0.0047 ± 116%
		Gas processing: 0.111 ± 186%
		Transmission: 0.074 ± 118%
		Storage: 0.080 ± 118%
$F_{NVC}$	=	Fraction of the population WITHOUT combustion vent controls
		Production: 0.988 ± 0.87%
		Gas processing: 0.900 ± 10% (estimated)
		Transmission: 0.852 ± 14.0%
		Storage: 0.840 ± 15.2%
$EF_{FT}$	=	Total methane emission rate scf per 1 MMscf throughput per dehydrator with a flash tank
		All: 3.57 + 102% /- 58%
$EF_{NT}$	=	Total methane emission rate scf per 1 MMscf throughput per dehydrator WITHOUT a flash tank
		All: 175.10 + 101% /- 50%



$EF_{SG}$	=	Incremental methane emission rate per 1 MMscf throughput per dehydrator that has stripping gas All: 670 + 40% / - 60%
OC	=	Glycol overcirculation factor--number of times the industry rule-of-thumb of 3 gallons glycol/pound water Production: 2.1 ± 41% Others: 1.0 ± 0%

All of the emission factors (EFs) in these equations, such as  $EF_{FT}$ ,  $EF_{NT}$ , and  $EF_{SG}$ , were derived from the modeling described in Section 5.2.

#### 5.4 AGR Emission Factor

The AGR emission factor was calculated by using process simulation for a typical unit. The estimated methane emissions were 965 scf  $CH_4$ /MMscf gas throughput. Assuming an average AGR gas throughput of 36.5 MMscfd (equal to a gas processing dehydrator throughput<sup>1</sup>) and a fraction of AGRs venting methane to the atmosphere of 0.18,<sup>8</sup> the methane emissions for a typical AGR would be 6083 scfd/AGR.

#### 5.5 Emission Factor Summary

The emission factors for each dehydrator industry segment and for AGRs are listed in Table 5-3.

**TABLE 5-3. SUMMARY OF GLYCOL DEHYDRATOR AND AGR EMISSION FACTORS**

Segment	Emission Factor (scf $CH_4$ /MMscf)
Production	275.6 ± 154%
Gas Processing	121.6 ± 202%
Transmission	93.72 ± 208%
Storage	117.2 ± 160%
AGRs	6083 scfd/AGR ± 105%

## 6.0 ANNUAL METHANE EMISSIONS

Annual methane emissions from glycol dehydrators in each industry segment and from AGRs were calculated by multiplying the activity factor by the emission factor. The results are as follows:

- Production:

$$275.6 \text{ scf CH}_4/\text{MMscf} \times 12.4 \times 10^6 \text{ MMscf} = 3.4 \text{ Bscf} \pm 192\%$$

- Gas Processing:

$$121.6 \text{ scf CH}_4/\text{MMscf} \times 8.63 \times 10^6 \text{ MMscf} = 1.1 \text{ Bscf} \pm 208\%$$

- Transmission:

$$93.72 \text{ scf CH}_4/\text{MMscf} \times 1.09 \times 10^6 \text{ MMscf} = 0.1 \text{ Bscf} \pm 392\%$$

- Storage:

$$117.2 \text{ scf CH}_4/\text{MMscf} \times 2.00 \times 10^6 \text{ MMscf} = 0.2 \text{ Bscf} \pm 167\%$$

- AGRs (Production and Gas Processing):

$$6083 \text{ scfd/unit} \times 371 \text{ units} \times 365 \text{ days} = 0.8 \text{ Bscf} \pm 109\%$$

The estimate for annual methane emissions from glycol dehydrators is 4.8 Bscf. The estimate of annual methane emissions from AGRs is 0.8 Bscf.

## 7.0 REFERENCES

1. Wright Killen & Co. *Natural Gas Dehydration: Status and Trends*. GRI-94/0099, Gas Research Institute, Chicago, IL, January 1994.
2. Myers, D.B. and M.R. Harrison. *Methane Emissions from the Natural Gas Industry, Volume 15: Gas-Assisted Glycol Pumps*. Final Report, GRI-94/0257.33 and EPA-600/R-96-080o. Gas Research Institute and U.S. Environmental Protection Agency, June 1996.
3. Stapper, B.E. *Methane Emissions from the Natural Gas Industry, Volume 5: Activity Factors*. Final Report, GRI-94/0257.22 and EPA-600/R-96-080e. Gas Research Institute and U.S. Environmental Protection Agency, June 1996.
4. Bell, L. "Worldwide Gas Processing." *Oil and Gas Journal*. June 13, 1994, pp. 63-91.
5. American Gas Association. *Gas Facts 1994: A Statistical Record of the Gas Industry*. Arlington, VA, 1994.
6. Texas Mid-Continent Oil and Gas Association (TMOGA) and Gas Processors Association (GPA), Dehydrator Survey, 1991.
7. Tannehill, C.C. and C. Galvin. *Business Characteristics of the Natural Gas Conditioning Industry*. Topical Report, GRI-93/0342, prepared by Purvin & Gertz, Inc., Gas Research Institute, May 1993.
8. Radian Corporation. *Investigation of U.S. Natural Gas Reserve Demographics and Gas Treatment Processes*, Topical Report, Gas Research Institute, January 1991.
9. Radian Corporation. ASPEN/SP<sup>®</sup> Modeling. Internal project files, 1993.
10. Radian Corporation. *Glycol Dehydrator Emissions: Sampling and Analytical Methods and Estimation Techniques*. GRI-94/0324, Gas Research Institute, Chicago, IL, March 1995.



**APPENDIX A**  
**Emission Source Sheets**

P-6  
**PRODUCTION SOURCE SHEET**

**SOURCES:** Glycol Dehydrators  
**COMPONENTS:** N/A  
**OPERATING MODE:** Normal Operation  
**EMISSION TYPE:** Vented  
**ANNUAL EMISSIONS:** 3.42 Bscf ± 192%

**BACKGROUND:**

Glycol dehydrators remove water from a gas stream by contacting the gas with glycol and then driving the water from the glycol by heating in the glycol reboiler and into the atmosphere. The glycol also absorbs a small amount of methane, and some methane can be driven off to the atmosphere through the reboiler vent.

**EMISSION FACTOR:** (275.57 scf/MMscf gas processed ± 154.48%)

A thermodynamic computer simulation was used to determine the most important emission-affecting variables for dehydrators. The variables are: gas throughput, existence of a flash tank, existence of stripping gas, existence of a gas driven pump, and existence of vent controls routed to a burner. Throughput, since its effect is linear, is handled by establishing an emission rate per unit of gas throughput. Emission rates per unit of throughput are then established for the other important emission affecting characteristics. Gas driven pumps are ignored here and handled in a separate source analysis (see *Methane Emissions from the Natural Gas Industry, Volume 15: Gas-Assisted Glycol Pumps*) (1). The emission factor is then:

$$EF = [ ( F_{FT} \times EF_{FT} ) + ( F_{NT} \times EF_{NT} ) + ( F_{SG} \times EF_{SG} ) ] \times F_{NVC} \times OC$$

$$= [ ( 0.265 \times 3.57 ) + ( 0.735 \times 175.10 ) + ( 0.00473 \times 670 ) ] \times 0.9882 \times 2.1$$

- $F_{FT}$  = Fraction of the population WITH flash tanks  
0.265 ± 8.35%
- $F_{NT}$  = Fraction of the population WITHOUT flash tanks  
0.735 ± 2.99%
- $F_{SG}$  = Fraction of the population WITH stripping gas  
0.00473 ± 115.78%
- $F_{NVC}$  = Fraction of the population WITHOUT combustion vent controls  
0.9882 ± 0.87%
- $EF_{FT}$  = Total methane emission rate scf per 1 MMscf throughput with a flash tank  
3.57 +102%/-58%
- $EF_{NT}$  = Total methane emission rate scf per 1 MMscf throughput WITHOUT a flash tank  
175.10 +101%/-50%
- $EF_{SG}$  = Incremental methane emission rate per 1 MMscf throughput per dehydrator that has stripping gas  
670 +40%/-60%
- $OC$  = Overcirculation factor for glycol--number of times the industry rule-of-thumb of 3 gallons glycol/lb water  
2.1 ± 41%

#### EF DATA SOURCES:

1. *Methane Emissions from the Natural Gas Industry, Volume 14: Glycol Dehydrators* (2) establishes emission affecting characteristics of dehydrators.
2. GRI/EPA site visit data establishes the  $F_{SG}$  and  $F_{NVC}$  for multiple sites (19 PROD sites).
3. An analysis of a combined database including TMOGA's 1019 dehydrators and GRI/EPA site visits 444 dehydrators established  $F_{FD}$  and  $F_{ND}$  for production dehydrators.
4. ASPEN computer simulations were used in combination with measured data to determine  $EF_{FD}$  and  $EF_{ND}$  from the dehydrator vent.
5. Sampling data from the GRI Glycol Sampling and Analytical Program for one dehydrator was used to determine  $EF_{SG}$  (*Glycol Dehydrator Emissions: Sampling and Analytical Methods and Estimation Techniques*) (3). The upper bound was calculated by assuming that all of the measured noncondensable vent gas was due to stripping gas that was 100% methane. The lower bound was calculated as the rule-of-thumb stripping gas rate recommended by a glycol dehydrator manufacturer.
6. Overcirculation factor determined using data from the GRI Glycol Sampling and Analytical Program data for ten dehydrators.

**EF PRECISION:** 275.57 scf/MMscf gas processed  $\pm$  154.48%

Basis:

The accuracy is propagated through the EF calculation from each term's accuracy:

1. ASPEN has been demonstrated to match actual dehydrators within  $\pm 20\%$  within the calculated confidence intervals obtained from site data.
2. Individual EF confidence intervals were calculated from the data used in the calculation.
3. Data from site visits has been assigned confidence intervals based upon the spread of the 444 dehydrators from GRI/EPA site data.

**ACTIVITY FACTOR:** (12.4 Tscf/year gas throughput in the production segment)

The amount of gas processed by glycol dehydrators in the production segment was calculated from the estimated number of glycol dehydrators in production and the average throughput capacity for production dehydrators (Wright Killen & Co., 1994). A capacity utilization factor was estimated based on observations at several sites in the GRI Glycol Dehydrator Sampling and Analytical Program.

#### AF DATA SOURCES:

The report: *Natural Gas Dehydration: Status and Trends* (4) by Wright Killen for the Gas Research Institute, provides data and describes the methodology used to develop an estimate of the gas dehydrator count for the U.S. The count also estimated the number in several industry segments: production, transmission, and gas processing.

Basis:

1. A GRI study by Wright Killen & Co. found 41700 dehydrators in the U.S. gas industry for 1993. Wright Killen also used a TMOGA/GPA database on dehydrators to split the population into the following industry segments:

Production:	25270
Processing:	7923
Transmission:	8507
TOTAL:	41700

The study also found that 95.0 % of the dehydrators were glycol for a total of 39,615 (versus molecular sieve or other types).

2. Site visit data on 24 transmission compressor stations shows:  $2/17 = 0.118$  per transmission compressor station, and  $17/6 = 2.83$  per storage compressor station. The site visit numbers would lead to an estimate of 1293 total transmission and storage dehydrators. Site visit data on 11 gas plants show 1.41 dehydrators per plant, or 1,024 in gas plants.

Subtracting processing, transmission, and storage glycol dehydrators from the total of 39,615 yields 37824 glycol dehydrators in production.

3. Average capacity of production dehydrators was reported to be 2 MMscfd by Wright Killen.

Information on actual dehydrator throughput as compared to design capacity is, in general, difficult to obtain especially for production field units. Data from several sites in the GRI Glycol Dehydrator Sampling and Analytical Program and other anecdotal information from various site visits indicate that capacity utilization may be less than 50%, so a value of 45% was chosen for the AF calculations.

**AF PRECISION:** 12.4 Tscf/year  $\pm$  61.87%

Basis:

The 90% confidence limits for total glycol dehydrators were established in the Wright Killen report. The confidence limits for the segments other than production were based on site visit data. Confidence limits for the capacity utilization was based on engineering judgement.

**ANNUAL METHANE EMISSIONS:** (3.4171 Bscf/yr  $\pm$  191.90%)

The annual methane emissions were determined by multiplying the dehydrator emission factor by the activity factor.

**REFERENCES**

1. Myers, D.B. and M.R. Harrison. *Methane Emissions from the Natural Gas Industry, Volume 15: Gas-Assisted Glycol Pumps*, Final Report, GRI-94/0257.33 and EPA-600/R-96-080o. Gas Research Institute and U.S. Environmental Protection Agency, June 1996.
2. Myers, D.B. *Methane Emissions from the Natural Gas Industry, Volume 14: Glycol Dehydrators*, Final Report, GRI-94/0257.31 and EPA-600/R-96-080n. Gas Research Institute and U.S. Environmental Protection Agency, June 1996.



3. Radian Corporation. *Glycol Dehydrator Emissions: Sampling and Analytical Methods and Estimation Techniques*. GRI-94/0324, Gas Research Institute, Chicago, IL, March 1995.
4. Wright Killen & Company. *Natural Gas Dehydration: Status and Trends*, Final Report. GRI-94/0099, Gas Research Institute, Chicago, Chicago, IL, January 1994.

T-6  
TRANSMISSION SOURCE SHEET

SOURCES: Glycol Dehydrators  
 OPERATING MODE: Normal Operation  
 EMISSION TYPE: Unsteady, Vented  
 COMPONENTS: Reboiler Vents  
 ANNUAL EMISSIONS: 0.10 Bscf ± 392%

**BACKGROUND:**

Glycol dehydrators remove water from a gas stream by contacting the gas with glycol and then driving the water from the glycol and into the atmosphere. The glycol also absorbs a small amount of methane, and some methane can be driven off to the atmosphere through the reboiler vent.

**EMISSION FACTOR: (93.72 scf/MMscf gas processed ± 207.99%)**

A thermodynamic computer simulation was used to determine the most important emission-affecting variables for dehydrators. The variables are: gas throughput, existence of a flash tank, existence of stripping gas, existence of a gas driven pump, existence of vent controls routed to a burner. Throughput, since its effect is linear, is handled by establishing an emission rate per gas throughput. Emission rates per throughput are then established for the other important emission affecting characteristics. The emission factor is then:

$$EF = [ ( F_{FT} \times EF_{FT} ) + ( F_{NT} \times EF_{NT} ) + ( F_{SG} \times EF_{SG} ) ] \times F_{NVC} \times OC$$

$$EF = [ ( 0.669 \times 3.57 ) + ( 0.331 \times 175.10 ) + ( 0.0741 \times 670 ) ] \times 0.852 \times 1.0$$

$F_{FT}$  = Fraction of the population WITH flash tanks  
0.669 ± 9.70%

$F_{NT}$  = Fraction of the population WITHOUT flash tanks  
0.331 ± 19.6%

$F_{SG}$  = Fraction of the population WITH stripping gas  
0.0741 ± 118.26%

$F_{NVC}$  = Fraction of the population WITHOUT combusted vent controls  
0.852 ± 14.0%

$EF_{FT}$  = Total CH<sub>4</sub> emission rate per 1 MMscf throughput for dehydrator that has a flash tank  
3.57 scf/MMscf (+102% / -58%)

$EF_{NT}$  = Total CH<sub>4</sub> emission rate per 1 MMscf throughput for dehydrator that does NOT have a flash tank  
175.1 scf/MMscf (+101% / -50%)

$EF_{SG}$  = Incremental emission rate per 1 MMscf throughput for dehydrator that has stripping gas  
670 scf/MMscf (+40% / -60%)

$OC$  = Overcirculation factor for glycol--number of times the industry rule-of-thumb of 3 gallons glycol/lb water  
1.0 ± 0%

## EF DATA SOURCES:

1. *Methane Emissions from the Natural Gas Industry, Volume 14: Glycol Dehydrators* (1) establishes emission affecting characteristics of dehydrators.
2. Site visit data establishes the  $F_{SG}$  and  $F_{NVC}$  for multiple sites. Wyoming ADQ data also verifies  $F_{NVC}$ , though it implies a higher  $F$ , and thus a higher overall EF.
3. TMOGA/GPA survey of 1019 dehydrators established  $F_{FD}$  and  $F_{ND}$  and TP for dehydrators.
4. ASPEN computer simulations were used to determine  $EF_{FD}$  and  $EF_{ND}$  from the dehydrator vent.
5. Sampling data from the GRI Glycol Dehydrator Sampling and Analytical Program for one dehydrator was used to determine  $EF_{SG}$  (1). The upper bound was calculated by assuming that all of the measured noncondensable vent gas was due to stripping gas that was 100% methane. The lower bound was calculated as the rule-of-thumb stripping gas rate recommended by a glycol dehydrator manufacturer.

EF ACCURACY: 93.72 scf/MMscf  $\pm$  207.99%

Basis:

The accuracy is propagated through the EF calculation from each term's accuracy:

1. ASPEN has been demonstrated to match actual dehydrators within  $\pm 20\%$  within the calculated confidence intervals obtained from site data.
2. Individual EF confidence intervals were calculated based upon the spread of the site averages.

**ACTIVITY FACTOR: (1.086 Tscf/year gas throughput in the transmission segment)**

The amount of gas processed by glycol dehydrators in the transmission segment was calculated from the estimated number of glycol dehydrators in transmission service and the average throughput capacity for transmission dehydrators [Wright Killen & Co., 1994 (2)]. See Source Sheet P-6 for a detailed discussion of the breakdown of glycol dehydrators into industry segments. The capacity utilization factor for transmission was assumed to be 1.

AF ACCURACY: 1.086 Tscf/year  $\pm$  143.85%

Basis:

1. Uncertainty based on confidence limits from the site visit data.

**ANNUAL METHANE EMISSIONS: (0.1018 Bscf/yr  $\pm$  391.75%)**

The annual methane emissions were determined by multiplying the dehydrator emission factor by the activity factor.

## REFERENCES

1. Myers, D.B. *Methane Emissions from the Natural Gas Industry, Volume 14: Glycol Dehydrators*, Final Report, GRI-94/0257.31 and EPA-600/R-96-080n. Gas Research Institute and U.S. Environmental Protection Agency, June 1996.
2. Wright Killen & Co. *Natural Gas Dehydration: Status and Trends*, Final Report, GRI-94/0099, Gas Research Institute, Chicago, IL, January 1994.

S-2  
STORAGE SOURCE SHEET

SOURCES: Glycol Dehydrators  
 OPERATING MODE: Normal Operation  
 EMISSION TYPE: Unsteady, Vented  
 COMPONENTS: Reboiler Vents  
 ANNUAL EMISSIONS: 0.23 Bscf ± 167%

**BACKGROUND:**

Glycol dehydrators remove water from a gas stream by contacting the gas with glycol and then driving the water from the glycol and into the atmosphere. The glycol also absorbs a small amount of methane, and some methane can be driven off to the atmosphere through the reboiler vent.

**EMISSION FACTOR:** (117.18 scf/MMscf ± 159.76%)

A thermodynamic computer simulation was used to determine the most important emission-affecting variables for dehydrators. The variables are: gas throughput, existence of a flash tank, existence of stripping gas, existence of a gas-assisted pump, existence of vent controls routed to a burner. Throughput, since its effect is linear, is handled by establishing an emission rate per gas throughput. Emission rates per throughput are then established for the other important emission affecting characteristics. The emission factor is then:

$$EF = [ ( F_{FT} \times EF_{FT} ) + ( F_{NT} \times EF_{NT} ) + ( F_{SG} \times EF_{SG} ) ] \times F_{NVC} \times OC$$

$$EF = [ ( 0.520 \times 3.57 ) + ( 0.480 \times 175.10 ) + ( 0.080 \times 670 ) ] \times 0.840 \times 1.0$$

$F_{FT}$  = Fraction of the population WITH flash tanks  
 0.520 ± 33.56%

$F_{ND}$  = Fraction of the population WITHOUT flash tanks  
 0.480 ± 36.25%

$F_{SG}$  = Fraction of the population WITH stripping gas  
 0.080 ± 118.44%

$F_{NVC}$  = Fraction of the population WITHOUT combusted vent controls  
 0.840 ± 15.24%

$EF_{FT}$  = Total CH<sub>4</sub> emission rate per 1 MMscf throughput for dehydrator that has a flash tank  
 3.57 (+102% / -58%)

$EF_{NT}$  = Total CH<sub>4</sub> emission rate per 1 MMscf throughput for dehydrator that does NOT have a flash tank  
 175.10 (+101% / -50%)

$EF_{SG}$  = Incremental emission rate per 1 MMscfd throughput for dehydrator that has stripping gas  
 670 (+40% / -60%)

OC = Overcirculation factor for glycol--number of times the industry rule-of-thumb of 3 gallons glycol/lb water  
 1.0 ± 0%

#### EF DATA SOURCES:

1. *Methane Emissions from the Natural Gas Industry, Volume 14: Glycol Dehydrators* (1) establishes emission affecting characteristics of dehydrators.
2. Site visit data establishes the  $F_{SG}$  and  $F_{NVC}$  for multiple sites. Wyoming ADQ data also verifies  $F_{NVC}$ , though it implies a higher  $F$ , and thus a higher overall EF.
3. TMOGA/GPA survey of 1019 dehydrators established  $F_{3P}$  and  $F_{ND}$  and TP for dehydrators.
4. ASPEN computer simulations were used to determine  $EF_{3P}$ , and  $EF_{ND}$  from the dehydrator vent.
5. Sampling data from the GRI Glycol Dehydrator Sampling and Analytical Program for one dehydrator was used to determine  $EF_{SG}$  (1). The upper bound was calculated by assuming that all of the measured noncondensable vent gas was due to stripping gas that was 100% methane. The lower bound was calculated as the rule-of-thumb stripping gas rate recommended by a glycol dehydrator manufacturer.

EF ACCURACY:  $117.18 \pm 159.76\%$

#### Basis:

The accuracy is propagated through the EF calculation from each term's accuracy:

1. ASPEN has been demonstrated to match actual dehydrators within  $\pm 20\%$  within the calculated confidence intervals obtained from site data.
2. Individual EF confidence intervals were calculated based upon the spread of the site averages.

#### ACTIVITY FACTOR: (2.00 Tscf/year gas throughput in the storage segment)

The amount of gas processed by glycol dehydrators in the storage segment was calculated from the estimated amount of gas withdrawn from underground storage. A total of 2.4 Tscf was withdrawn in 1992, and it is assumed that most stored gas is dehydrated.

AF ACCURACY: 2.00 Tscf/year  $\pm 25\%$

#### Basis:

1. Uncertainty based on estimate of confidence limits.

#### ANNUAL METHANE EMISSIONS: (0.2344 Bscf $\pm 166.56\%$ )

The annual methane emissions were determined by multiplying the dehydrator emission factor by the activity factor.

#### REFERENCES

1. Myers, D.B. *Methane Emissions from the Natural Gas Industry, Volume 14: Glycol Dehydrators*, Final Report, GRI-94/0257.31 and EPA-600/R-96-080n. Gas Research Institute and U.S. Environmental Protection Agency, June 1996.

**GP-2  
PROCESSING SOURCE SHEET**

**SOURCES:** Glycol Dehydrators  
**COMPONENTS:** Reboiler Vent  
**OPERATING MODE:** Normal Operation  
**EMISSION TYPE:** Unsteady, Vented  
**ANNUAL EMISSIONS:** 1.05 Bscf ± 208%

**BACKGROUND:**

Glycol dehydrators remove water from a gas stream by contacting the gas with glycol and then driving the water from the glycol and into the atmosphere. The glycol also absorbs a small amount of methane, and some methane can be driven off to the atmosphere through the reboiler vent.

**EMISSION FACTOR: (121.55 scf/MMscf ± 201.96%)**

A thermodynamic computer simulation was used to determine the most important emission-affecting variables for dehydrators. The variables are: (gas throughput, existence of a flash tank, existence of stripping gas, existence of a gas-assisted pump, existence of vent controls routed to a burner). Throughput, since its effect is linear, is handled by establishing an emission rate per gas throughput. Emission rates per throughput are then established for the other important emission affecting characteristics. Gas driven pumps are ignored here and handled in a separate source analysis. The emission factor is then:

$$EF = [ ( F_{FT} \times EF_{FT} ) + ( F_{NT} \times EF_{NT} ) + ( F_{SG} \times EF_{SG} ) ] \times F_{NVC} \times OC$$

$$EF = [ ( 0.667 \times 3.57 ) + ( 0.333 \times 175.10 ) + ( 0.111 \times 670 ) ] \times 0.900 \times 1.0$$

$F_{FT}$  = Fraction of the population WITH flash tanks  
0.667 ± 10.13%

$F_{NT}$  = Fraction of the population WITHOUT flash tanks = 1- $F_{FT}$   
0.333 ± 20.12%

$F_{SG}$  = Fraction of the population WITH stripping gas  
0.111 ± 186%

$F_{NVC}$  = Fraction of the population WITHOUT combusted vent controls  
0.90 ± 10%

$EF_{FT}$  = Total CH<sub>4</sub> emission rate per 1 MMscf throughput for dehydrator that has a flash tank  
3.57 (+102% / -58%)

$EF_{NT}$  = Total CH<sub>4</sub> emission rate per 1 MMscf throughput for dehydrator that does NOT have a flash tank  
175.10 (+101% / -50%)

$EF_{SG}$  = Incremental emission rate per 1 MMscfd throughput for dehydrator that has stripping gas  
670 (+40% / -60%)

OC = Overcirculation factor for glycol--number of times the industry rule-of-thumb of 3 gallons glycol/lb water  
1.0 ± 0%

#### EF DATA SOURCES:

1. *Methane Emissions from the Natural Gas Industry, Volume 14: Glycol Dehydrators* (1) establishes emission affecting characteristics of dehydrators.
2. Site visit data establish the  $F_{SG}$  and  $F_{NVC}$  for multiple sites (7 PROC sites with dehydrators).
3. TMOGA/GPA survey of 207 gas plant dehydrators established  $F_{3P}$  and  $F_{ND}$  and TP for dehydrators for the processing segment.
4. ASPEN computer simulations were used to determine  $EF_{3P}$ , and  $EF_{ND}$  from the dehydrator vent.
5. Sampling data from the GRI Glycol Dehydrator Sampling and Analytical Program for one dehydrator was used to determine  $EF_{SG}$  (*Glycol Dehydrator Emissions: Sampling and Analytical Methods and Estimation Techniques*) (2). The upper bound was calculated by assuming that all of the measured noncondensable vent gas was due to stripping gas that was 100% methane. The lower bound was calculated as the rule-of-thumb stripping gas rate recommended by a glycol dehydrator manufacturer.

EF ACCURACY 121.55 scf/MMscf  $\pm$  201.96%

#### Basis:

The accuracy is rigorously propagated through the EF calculation from each term's accuracy:

1. ASPEN has been demonstrated to match actual dehydrators within  $\pm$  20% within the calculated confidence intervals obtained from site data.
2. Individual EF confidence intervals were calculated from the other data based upon the spread of the 11 site averages.

#### ACTIVITY FACTOR: (8.63 Tscf/year gas throughput in the gas processing segment)

The glycol dehydrator throughput is estimated from the fraction of gas processed by refrigerated processes (as opposed to dry bed dehydration for cryogenic processes). The estimate was obtained from the *Oil & Gas Journal* (3) annual Gas Processing Survey. Of a total of 17.44 Tscf, 8.63 Tscf were determined to be dehydrated by glycol.

AF ACCURACY: 8.63 Tscf/year  $\pm$  22.45%

#### Basis:

1. Uncertainty based on estimate of confidence limits for *Oil and Gas Journal* survey.

#### AF DATA SOURCES:

1. *Oil & Gas Journal* (3) annual Gas Processing Survey.

#### ANNUAL METHANE EMISSIONS: (1.0490 Bscf $\pm$ 208.20%)

The annual methane emissions were determined by multiplying the dehydrator emission factor by the activity factor.

#### REFERENCES

1. Myers, D.B. *Methane Emissions from the Natural Gas Industry, Volume 14: Glycol Dehydrators*, Final Report, GRI-94/0257.31 and EPA-600/R-96-080n. Gas Research Institute and U.S. Environmental Protection Agency, June 1996.

2. Radian Corporation. *Glycol Dehydrator Emissions: Sampling and Analytical Methods and Estimation Techniques*. GRI-94/0324, Gas Research Institute, Chicago, IL, March 1995.
3. *Oil & Gas Journal*. 1992 Worldwide Gas Processing Survey Database, 1993.



**GP-3  
PROCESSING SOURCE SHEET**

**SOURCES:** Acid Gas Removal (AGR) Units  
**OPERATING MODE:** Normal Operation  
**EMISSION TYPE:** Unsteady, Vented  
**ANNUAL EMISSIONS:** 0.82 Bscf ± 109%

**BACKGROUND:**

AGR units remove acid gas (H<sub>2</sub>S and CO<sub>2</sub>) from a natural gas stream by contacting the gas with material (usually amines) and then driving the absorbed components from the solvent. The amines can also absorb a small amount of methane, and some methane can be driven off to the atmosphere through the reboiler vent to the atmosphere.

**EMISSION FACTOR: (6083 scfd/avg AGR)**

AGRs were assumed to have an absorption of methane similar to water, since the typical AGR solution contains over 50% water. The methane emissions were calculated using an ASPEN PLUS process simulation based on an actual DEA unit (1). AGRs were assumed to have no three-phase flash tanks nor stripping gas. The average AGR throughput (MMscfd) was determined from a 1982 API study (2), and multiplied times the emission rate (CH<sub>4</sub>/MMscfd). The emission factor is then:

$$EF = EF_{NT} \times F_{NVC} \times TP$$

$F_{NVC}$  = Fraction of the AGRs that do vent the waste stream  
0.18 ± 10%

$TP$  = Average throughput for AGRs (MMscfd)  
35.02 ± 20%

$EF_{NT}$  = Total "CH<sub>4</sub> scfd emission rate per 1 MMscfd throughput" for an AGR  
965 ± 100%

**EF DATA SOURCES:**

1. ASPEN PLUS process simulations based on an actual DEA unit were used to determine  $EF_{NT}$  from the reboiler vent. It was assumed that AGRs have an absorption of methane similar to water.
2. 1982 API Survey, quoted in Investigation of US Natural Gas Reserve Demographics and Gas Treatment Processes, shows 287 AGR units, with a cumulative throughput of 10052 MMscfd (3). The survey also shows split of AGR vent dispositions: 50% burned, 32% to sulfur recover, and 18% vented.

**EF ACCURACY: 6083 ± 104.92%**

**Basis:**

1. The accuracy is based upon engineering judgement that the methane solubility in AGR solutions is similar to the solubility in water.

**ACTIVITY FACTOR: (371 active AGR units in the U.S.)**

The number of AGR units in the U.S. have all been assumed to be in the processing segment. The activity factor was extracted from the Purvin & Gertz survey.

**AF DATA SOURCES:**

1. Purvin & Gertz, Inc. *Business Characteristics of the Natural Gas Conditioning Industry*, 1993 (4).

**AF ACCURACY: 371 ± 20%**

**Basis:**

1. The accuracy is based upon engineering judgement. The survey should have excellent accuracy (± 5%), but the upper bound at 90% confidence was revised upward to 20% to be conservative.

**ANNUAL METHANE EMISSIONS: (0.8237 Bscf ± 108.85%)**

The annual methane emissions were determined by multiplying an emission factor for an average dehydrator by the population of AGRs in the segment.

**REFERENCES**

1. Myers, D.B. *Methane Emissions from the Natural Gas Industry, Volume 14: Glycol Dehydrators*, Final Report, GRI-94/0257.31 and EPA-600/R-96-080n. Gas Research Institute and U.S. Environmental Protection Agency, June 1996.
2. American Petroleum Institute. 1982 Survey of Gas Processing Units Database. Washington, DC, 1982.
3. Radian Corporation. *Investigation of U.S. Natural Gas Reserve Demographics and Gas Treatment Processes*, Topical Report, Gas Research Institute, January 1991.
4. Tannehill, C.C. and C. Galvin. *Business Characteristics of the Natural Gas Conditioning Industry*. Topical Report, GRI-93/0342, prepared by Purvin & Gertz, Inc., Gas Research Institute, May 1993.

**TECHNICAL REPORT DATA**  
(Please read Instructions on the reverse before completing)

1. REPORT NO. EPA-600/R-96-080n		2.	3. RECIPIENT'S ACCESSION NO.	
4. TITLE AND SUBTITLE Methane Emissions from the Natural Gas Industry, Volumes 1-15 (Volume 14: Glycol Dehydrators)		5. REPORT DATE June 1996		6. PERFORMING ORGANIZATION CODE
7. AUTHOR(S) L. Campbell, M. Campbell, M. Cowgill, D. Epperson, M. Hall, M. Harrison, K. Hummel, D. Myers, T. Shires, B. Stapper, C. Stapper, J. Wessels, and *		8. PERFORMING ORGANIZATION REPORT NO. DCN 96-263-081-17		
9. PERFORMING ORGANIZATION NAME AND ADDRESS Radian International LLC P. O. Box 201088 Austin, Texas 78720-1088		10. PROGRAM ELEMENT NO.		11. CONTRACT/GRANT NO. 5091-251-2171 (GRI) 68-DI-0031 (EPA)
12. SPONSORING AGENCY NAME AND ADDRESS EPA, Office of Research and Development Air Pollution Prevention and Control Division Research Triangle Park, NC 27711		13. TYPE OF REPORT AND PERIOD COVERED Final; 3/91-4/96		14. SPONSORING AGENCY CODE EPA/600/13
15. SUPPLEMENTARY NOTES EPA project officer is D. A. Kirchgessner, MD-63, 919/541-4021. Cosponsor GRI project officer is R. A. Lott, Gas Research Institute, 8600 West Bryn Mawr Ave., Chicago, IL 60631. (*)H. Williamson (Block 7).				
16. ABSTRACT The 15-volume report summarizes the results of a comprehensive program to quantify methane (CH <sub>4</sub> ) emissions from the U.S. natural gas industry for the base year. The objective was to determine CH <sub>4</sub> emissions from the wellhead and ending downstream at the customer's meter. The accuracy goal was to determine these emissions within +/-0.5% of natural gas production for a 90% confidence interval. For the 1992 base year, total CH <sub>4</sub> emissions for the U.S. natural gas industry was 314 +/- 105 Bscf (6.04 +/- 2.01 Tg). This is equivalent to 1.4 +/- 0.5% of gross natural gas production, and reflects neither emissions reductions (per the voluntary AmeriGas Association/EPA Star Program) nor incremental increases (due to increased gas usage) since 1992. Results from this program were used to compare greenhouse gas emissions from the fuel cycle for natural gas, oil, and coal using the global warming potentials (GWPs) recently published by the Intergovernmental Panel on Climate Change (IPCC). The analysis showed that natural gas contributes less to potential global warming than coal or oil, which supports the fuel switching strategy suggested by the IPCC and others. In addition, study results are being used by the natural gas industry to reduce operating costs while reducing emissions.				
17. KEY WORDS AND DOCUMENT ANALYSIS				
a. DESCRIPTORS		b. IDENTIFIERS/OPEN ENDED TERMS	c. COSATI Field/Group	
Pollution Emission Greenhouse Effect Natural Gas Gas Pipelines Methane		Pollution Prevention Stationary Sources Global Warming	13B 14G 04A 21D 15E 07C	
18. DISTRIBUTION STATEMENT  Release to Public		19. SECURITY CLASS (This Report) Unclassified	21. NO. OF PAGES 47	
		20. SECURITY CLASS (This page) Unclassified	22. PRICE	

U.S. ENVIRONMENTAL PROTECTION AGENCY  
Office of Research and Development  
National Risk Management Research Laboratory  
Technology Transfer and Support Division  
Cincinnati, Ohio 45268

---

OFFICIAL BUSINESS  
PENALTY FOR PRIVATE USE, \$300  
AN EQUAL OPPORTUNITY EMPLOYER

*If your address is incorrect, please change on the above label  
tear off; and return to the above address.  
If you do not desire to continue receiving these technical  
reports, CHECK HERE ; tear off label, and return it to the  
above address.*

Publication No. EPA- 600 / R- 96- 080 n