

Water



Development **Final**

Document for

Effluent Limitations

Guidelines and Standards

for the Nonferrous Metals

Forming and Metal Powders

Point Source Category

Volume III



DEVELOPMENT DOCUMENT
for
EFFLUENT LIMITATIONS GUIDELINES AND STANDARDS
for the
NONFERROUS METALS FORMING AND METAL POWDERS
POINT SOURCE CATEGORY
VOLUME III

Lee M. Thomas
Administrator

Lawrence J. Jensen
Assistant Administrator for Water

William A. Whittington
Director
Office of Water Regulations and Standards



Devereaux Barnes, Acting Director
Industrial Technology Division

Ernst P. Hall, P.E., Chief
Metals Industries Branch

Janet K. Goodwin
Technical Project Officer

September 1986

U.S. Environmental Protection Agency
Office of Water
Office of Water Regulations and Standards
Industrial Technology Division
Washington, D.C. 20460

This document is divided into three volumes. Volume I contains Sections I through IV. Volume II contains Sections V and VI. Volume III contains Sections VII through XVI.

SECTION I	SUMMARY AND CONCLUSIONS
SECTION II	RECOMMENDATIONS
SECTION III	INTRODUCTION
SECTION IV	INDUSTRY SUBCATEGORIZATION
SECTION V	WATER USE AND WASTEWATER CHARACTERISTICS
SECTION VI	SELECTION OF POLLUTANT PARAMETERS
SECTION VII	CONTROL AND TREATMENT TECHNOLOGY
SECTION VIII	COST OF WASTEWATER TREATMENT AND CONTROL
SECTION IX	BEST PRACTICABLE CONTROL TECHNOLOGY CURRENTLY AVAILABLE
SECTION X	BEST AVAILABLE TECHNOLOGY ECONOMICALLY ACHIEVABLE
SECTION XI	NEW SOURCE PERFORMANCE STANDARDS
SECTION XII	PRETREATMENT STANDARDS
SECTION XIII	BEST CONVENTIONAL POLLUTANT CONTROL TECHNOLOGY
SECTION XIV	ACKNOWLEDGMENTS
SECTION XV	GLOSSARY
SECTION XVI	REFERENCES

CONTENTS

<u>Section</u>		<u>Page</u>
I	SUMMARY AND CONCLUSIONS Methodology Technology Basis for Limitations and Standards	1
II	RECOMMENDATIONS BPT and BAT Mass Limitations New Source Performance Standards Pretreatment Standards for Existing and New Sources	7
III	INTRODUCTION Legal Authority Data Collection and Utilization Description of the Nonferrous Metals Forming Category Description of Nonferrous Metals Forming Processes	319
IV	INDUSTRY SUBCATEGORIZATION Evaluation and Selection of Subcategorization Factors Production Normalizing Parameter Selection Description of Subcategories	385
V	WATER USE AND WASTEWATER CHARACTERISTICS Data Sources Water Use and Wastewater Characteristics	413
VI	SELECTION OF POLLUTANT PARAMETERS Rationale for Selection of Pollutant Parameters Description of Pollutant Parameters Pollutant Selection by Subcategory	1119
VII	CONTROL AND TREATMENT TECHNOLOGY End-of-Pipe Treatment Technologies Major Technologies Major Technology Effectiveness Minor Technologies In-Process Pollution Control Techniques	1311

CONTENTS (Continued)

<u>Section</u>		<u>Page</u>
VIII	COST OF WASTEWATER TREATMENT AND CONTROL	1461
	Summary of Cost Estimates	
	Cost Estimation Methodology	
	Cost Estimates for Individual Treatment Technologies	
	Compliance Cost Estimation	
	Nonwater Quality Aspects	
IX	BEST PRACTICABLE CONTROL TECHNOLOGY	1553
	CURRENTLY AVAILABLE	
	Technical Approach to BPT	
	Lead-Tin-Bismuth Forming Subcategory	
	Magnesium Forming Subcategory	
	Nickel-Cobalt Forming Subcategory	
	Precious Metals Forming Subcategory	
	Refractory Metals Forming Subcategory	
	Titanium Forming Subcategory	
	Uranium Forming Subcategory	
	Zinc Forming Subcategory	
	Zirconium Hafnium Forming Subcategory	
	Metal Powders Subcategory	
	Application of Regulation in Permits	
X	BEST AVAILABLE TECHNOLOGY ECONOMICALLY	1757
	ACHIEVABLE	
	Technical Approach to BAT	
	BAT Option Selection	
	Regulated Pollutant Parameters	
	Lead-Tin-Bismuth Forming Subcategory	
	Magnesium Forming Subcategory	
	Nickel-Cobalt Forming Subcategory	
	Precious Metals Forming Subcategory	
	Refractory Metals Forming Subcategory	
	Titanium Forming Subcategory	
	Uranium Forming Subcategory	
	Zinc Forming Subcategory	
	Zirconium-Hafnium Forming Subcategory	
	Metals Powders Subcategory	
XI	NEW SOURCE PERFORMANCE STANDARDS	1915
	Technical Approach to NSPS	
	NSPS Option Selection	
	Regulated Pollutant Parameter	
	New Source Performance Standards	

CONTENTS (Continued)

<u>Section</u>		<u>Page</u>
XII	PRETREATMENT STANDARDS Introduction of Nonferrous Metals Forming Wastewater into POTW Technical Approach to Pretreatment PSES and PSNS Option Selection Regulated Pollutant Parameters Pretreatment Standards	2013
XIII	BEST CONVENTIONAL POLLUTANT CONTROL TECHNOLOGY	2187
XIV	ACKNOWLEDGEMENTS	2189
XV	GLOSSARY	2191
XVI	REFERENCES	2211

LIST OF TABLES

<u>Table</u>	<u>Title</u>	<u>Page</u>
III-1	Metal Types Not Formed on a Commercial Scale, or for which Forming Operations Generate No Wastewater	356
III-2	Metal Types Covered Under the Nonferrous Metals Forming Category	357
III-3	Years Since Nonferrous Forming Operations Began at Plant	358
III-4	Nonferrous Metal Production by Product Formed in 1981	359
IV-1	Number of Plants Discharging Nonferrous Metals Forming Wastewater, By Subcategory	411
V-1	Number of Samples Per Waste Stream, By Subcategory	478
V-2	Sample Analysis Laboratories	483
V-3	Nonpriority Pollutants Analyzed for During Sampling Effort Supporting This Regulation	484
V-4	Results of Chemical Analyses of Sampled Lead and Nickel Extrusion Press and Solution Heat Treatment Contact Cooling Water	486
V-5	Results of Chemical Analyses of Sampled Lead, Nickel, and Precious Metals Rolling Spent Emulsions	487
V-6	Lead-Tin-Bismuth Rolling Spent Emulsions	488
V-7	Lead-Tin-Bismuth Rolling Spent Emulsions Raw Wastewater Sampling Data	489
V-8	Lead-Tin-Bismuth Rolling Spent Soap Solutions	492

LIST OF TABLES (Continued)

<u>Table</u>	<u>Title</u>	<u>Page</u>
V-9	Lead-Tin-Bismuth Rolling Spent Neat Oils	493
V-10	Lead-Tin-Bismuth Drawing Spent Emulsions	494
V-11	Lead-Tin-Bismuth Drawing Spent Soap Solutions	495
V-12	Lead-Tin-Bismuth Drawing Spent Soap Solutions Raw Wastewater Characteristics	496
V-13	Lead-Tin-Bismuth Extrusion Press or Solution Heat Treatment Contact Cooling Water	497
V-14	Lead-Tin-Bismuth Extrusion Press Solution Heat Treatment Contact Cooling Water Raw Wastewater Characteristics	498
V-15	Lead-Tin-Bismuth Extrusion Press Hydraulic Fluid Leakage	501
V-16	Lead-Tin-Bismuth Swaging Spent Emulsions	502
V-17	Lead-Tin-Bismuth Continuous Strip Casting Contact Cooling Water	503
V-18	Lead-Tin-Bismuth Continuous Strip Casting Contact Cooling Water Raw Wastewater Characteristics	504
V-19	Lead-Tin-Bismuth Semi-Continuous Ingot Casting Contact Cooling Water	506
V-20	Lead-Tin-Bismuth Semi-Continuous Ingot Casting Contact Cooling Water Raw Wastewater Characteristics	507
V-21	Lead-Tin-Bismuth Shot Casting Con- tact Cooling Water	510

LIST OF TABLES (Continued)

<u>Table</u>	<u>Title</u>	<u>Page</u>
V-22	Lead-Tin-Bismuth Shot Casting Contact Cooling Water Raw Wastewater	511
V-23	Lead-Tin-Bismuth Shot Forming Wet Air Pollution Control Blowdown	514
V-24	Lead-Tin-Bismuth Alkaline Cleaning Spent Baths	515
V-25	Lead-Tin-Bismuth Alkaline Cleaning Spent Baths Raw Wastewater Sampling Data	516
V-26	Lead-Tin-Bismuth Alkaline Cleaning Rinse	519
V-27	Lead-Tin-Bismuth Alkaline Cleaning Rinse Raw Wastewater Sampling Data	520
V-28	Magnesium Rolling Spent Emulsions	524
V-29	Magnesium Forging Spent Lubricants	525
V-30	Magnesium Forging Contact Cooling Water	526
V-31	Magnesium Forging Equipment Cleaning Wastewater	527
V-32	Magnesium Direct Chill Casting Con- tact Cooling Water	528
V-33	Magnesium Surface Treatment Spent Baths	529
V-34	Magnesium Surface Treatment Spent Baths Raw Wastewater Sampling Data	530
V-35	Magnesium Surface Treatment Rinse	535
V-36	Magnesium Surface Treatment Rinse Raw Wastewater Sampling Data	536

LIST OF TABLES (Continued)

<u>Table</u>	<u>Title</u>	<u>Page</u>
V-37	Magnesium Sawing or Grinding Spent Emulsions	548
V-38	Magnesium Wet Air Pollution Control Blowdown	549
V-39	Magnesium Wet Air Pollution Control Blowdown Raw Wastewater Sampling Data	550
V-40	Nickel-Cobalt Rolling Spent Neat Oils	552
V-41	Nickel-Cobalt Rolling Spent Emulsions	553
V-42	Nickel-Cobalt Rolling Spent Emulsions Raw Wastewater Sampling Data	554
V-43	Nickel-Cobalt Rolling Contact Cooling Water	558
V-44	Nickel-Cobalt Rolling Contact Cooling Water Raw Wastewater Sampling Data	559
V-45	Nickel-Cobalt Tube Reducing Spent Lubricants	566
V-46	Nickel-Cobalt Tube Reducing Spent Lubricants Raw Wastewater Sampling Data	567
V-47	Nickel-Cobalt Drawing Spent Neat Oils	570
V-48	Nickel-Cobalt Drawing Spent Emulsions	571
V-49	Nickel-Cobalt Drawing Spent Emulsions Raw Wastewater Sampling Data	572
V-50	Nickel-Cobalt Extrusion Spent Lubricants	574
V-51	Nickel-Cobalt Extrusion Press and Solution Heat Treatment Contact Cooling Water	575

LIST OF TABLES (Continued)

<u>Table</u>	<u>Title</u>	<u>Page</u>
V-52	Nickel-Cobalt Extrusion Press and Solution Heat Treatment Contact Cooling Water Raw Wastewater Sampling Data	576
V-53	Nickel-Cobalt Extrusion Press Hydraulic Fluid Leakage	579
V-54	Nickel-Cobalt Extrusion Press Hydraulic Fluid Leakage Raw Wastewater Sampling Data	580
V-55	Nickel-Cobalt Forging Spent Lubricants	584
V-56	Nickel-Cobalt Forging Contact Cooling Water	585
V-57	Nickel-Cobalt Forging Contact Cooling Water Raw Wastewater Sampling Data	586
V-58	Nickel-Cobalt Forging Equipment Cleaning Wastewater	590
V-59	Nickel-Cobalt Forging Press Hydraulic Fluid Leakage	591
V-60	Nickel-Cobalt Forging Press Hydraulic Fluid Leakage Raw Wastewater Sampling Data	592
V-61	Nickel-Cobalt Metal Powder Production Atomization Wastewater	595
V-62	Nickel-Cobalt Metal Powder Production Atomization Wastewater Raw Wastewater Sampling Data	596
V-63	Nickel-Cobalt Stationary Casting Contact Cooling Water	601
V-64	Nickel-Cobalt Vacuum Melting Steam Condensate	602

LIST OF TABLES (Continued)

<u>Table</u>	<u>Title</u>	<u>Page</u>
V-65	Nickel-Cobalt Vacuum Melting Steam Condensate Raw Wastewater Sampling Data	603
V-66	Nickel-Cobalt Annealing and Solution Heat Treatment Contact Cooling Water	606
V-67	Nickel-Cobalt Annealing and Solution Heat Treatment Contact Cooling Water Raw Wastewater Sampling Data	607
V-68	Nickel-Cobalt Surface Treatment Spent Baths	611
V-69	Nickel-Cobalt Surface Treatment Spent Baths Raw Wastewater Sampling Data	612
V-70	Nickel-Cobalt Surface Treatment Rinse	620
V-71	Nickel-Cobalt Surface Treatment Rinse Raw Wastewater Sampling Data	621
V-72	Nickel-Cobalt Ammonia Rinse	635
V-73	Nickel-Cobalt Ammonia Rinse Raw Wastewater Sampling Data	636
V-74	Nickel-Cobalt Alkaline Cleaning Spent Baths	639
V-75	Nickel-Cobalt Alkaline Cleaning Spent Baths Raw Wastewater Sampling Data	640
V-76	Nickel-Cobalt Alkaline Cleaning Rinse	646
V-77	Nickel-Cobalt Alkaline Cleaning Rinse Raw Wastewater Sampling Data	647
V-78	Nickel-Cobalt Molten Salt Rinse	654
V-79	Nickel-Cobalt Molten Salt Rinse Raw Wastewater Sampling Data	655

LIST OF TABLES (Continued)

<u>Table</u>	<u>Title</u>	<u>Page</u>
V-80	Nickel-Cobalt Sawing or Grinding Spent Emulsions	661
V-81	Nickel-Cobalt Sawing or Grinding Spent Emulsions Raw Wastewater Sampling Data	662
V-82	Nickel-Cobalt Sawing or Grinding Rinse	685
V-83	Nickel-Cobalt Steam Cleaning Condensate	686
V-84	Nickel-Cobalt Hydrostatic Tube Testing and Ultrasonic Testing Wastewater	687
V-85	Nickel-Cobalt Dye Penetrant Testing Wastewater	688
V-86	Nickel-Cobalt Dye Penetrant Testing Wastewater Raw Wastewater Sampling Data	689
V-87	Nickel-Cobalt Wet Air Pollution Control Blowdown	691
V-88	Nickel-Cobalt Wet Air Pollution Control Blowdown Raw Wastewater Sampling Data	692
V-89	Nickel-Cobalt Electrocoating Rinse	697
V-90	Precious Metals Rolling Spent Neat Oils	698
V-91	Precious Metals Rolling Spent Emulsions	699
V-92	Precious Metals Rolling Spent Emulsions Raw Wastewater Sampling Data	700
V-93	Precious Metals Drawing Spent Neat Oils	705
V-94	Precious Metals Drawing Spent Emulsions	706

LIST OF TABLES (Continued)

<u>Table</u>	<u>Title</u>	<u>Page</u>
V-95	Precious Metals Drawing Spent Emulsions Raw Wastewater Sampling Data	707
V-96	Precious Metals Drawing Spent Soap Solutions	710
V-97	Precious Metals Metal Powder Production Atomization Wastewater	711
V-98	Precious Metals Direct Chill Casting Contact Cooling	712
V-99	Precious Metals Shot Casting Contact Cooling Water	713
V-100	Precious Metals Shot Casting Contact Cooling Water Raw Wastewater Sampling Data	714
V-101	Precious Metals Stationary Casting Contact Cooling Water	717
V-102	Precious Metals Semi-Continuous and Continuous Casting Contact Cooling Water	718
V-103	Precious Metals Semi-Continuous and Continuous Casting Contact Cooling Water Raw Wastewater Sampling Data	719
V-104	Precious Metals Heat Treatment Con- tact Cooling Water	723
V-105	Precious Metals Surface Treatment Spent Baths	724
V-106	Precious Metals Surface Treatment Rinse	725
V-107	Precious Metals Surface Treatment Rinse Raw Wastewater Sampling Data	726
V-108	Precious Metals Alkaline Cleaning Spent Baths	732

LIST OF TABLES (Continued)

<u>Table</u>	<u>Title</u>	<u>Page</u>
V-109	Precious Metals Alkaline Cleaning Rinse	733
V-110	Precious Metals Alkaline Cleaning Prebonding Wastewater	734
V-111	Precious Metals Alkaline Cleaning Prebonding Wastewater Raw Wastewater Sampling Data	735
V-112	Precious Metals Tumbling or Burnishing Wastewater	740
V-113	Precious Metals Tumbling or Burnishing Wastewater Raw Wastewater Sampling Data	741
V-114	Precious Metals Sawing or Grinding Spent Neat Oils	745
V-115	Precious Metals Sawing or Grinding Spent Emulsions	746
V-116	Precious Metals Sawing or Grinding Spent Emulsions Raw Wastewater Sampling Data	747
V-117	Precious Metals Pressure Bonding Contact Cooling Water	750
V-118	Precious Metals Pressure Bonding Contact Cooling Water Raw Wastewater Sampling Data	751
V-119	Precious Metals Wet Air Pollution Control Blowdown	754
V-120	Refractory Metals Rolling Spent Neat Oils and Graphite-Based Lubricants	755
V-121	Refractory Metals Rolling Spent Emulsions	756
V-122	Refractory Metals Drawing Spent Lubricants	757
V-123	Refractory Metals Extrusion Spent Lubricants	758

LIST OF TABLES (Continued)

<u>Table</u>	<u>Title</u>	<u>Page</u>
V-124	Refractory Metals Extrusion Press Hydraulic Fluid Leakage	759
V-125	Refractory Metals Extrusion Press Hydraulic Fluid Leakage Raw Wastewater Sampling Data	760
V-126	Refractory Metals Forging Spent Lubricants	762
V-127	Refractory Metals Forging Contact Cooling Water	763
V-128	Refractory Metals Metal Powder Production Wastewater	764
V-129	Refractory Metals Metal Powder Production Floor Wash Wastewater	765
V-130	Refractory Metals Metal Powder Pressing Spent Lubricants	766
V-131	Refractory Metals Surface Treatment Spent Baths	767
V-132	Refractory Metals Surface Treatment Spent Baths Raw Wastewater Sampling Data	768
V-133	Refractory Metals Surface Treatment Rinse	771
V-134	Refractory Metals Surface Treatment Rinse Raw Wastewater Sampling Data	772
V-135	Refractory Metals Alkaline Cleaning Spent Baths	778
V-136	Refractory Metals Alkaline Cleaning Spent Baths Raw Wastewater Sampling Data	779
V-137	Refractory Metals Alkaline Cleaning Rinse	781
V-138	Refractory Metals Molten Salt Rinse	782
V-139	Refractory Metals Molten Salt Rinse Raw Wastewater Sampling Data	783

LIST OF TABLES (Continued)

<u>Table</u>	<u>Title</u>	<u>Page</u>
V-140	Refractory Metals Tumbling or Burnishing Wastewater	789
V-141	Refractory Metals Tumbling or Burnishing Wastewater Raw Wastewater Sampling Data	790
V-142	Refractory Metals Sawing or Grinding Spent Neat Oils	796
V-143	Refractory Metals Sawing or Grinding Spent Emulsions	797
V-144	Refractory Metals Sawing or Grinding Spent Emulsions Raw Wastewater Sampling Data	798
V-145	Refractory Metals Sawing or Grinding Contact Cooling Water	800
V-146	Refractory Metals Sawing or Grinding Contact Cooling Water Raw Wastewater Sampling Data	801
V-147	Refractory Metals Sawing or Grinding Rinse	805
V-148	Refractory Metals Dye Penetrant Testing Wastewater	806
V-149	Refractory Metals Dye Penetrant Testing Wastewater Raw Wastewater Sampling Data	807
V-150	Refractory Metals Equipment Cleaning Wastewater	810
V-151	Refractory Metals Equipment Cleaning Wastewater Raw Wastewater Sampling Data	811
V-152	Refractory Metals Miscellaneous Wastewater Sources	813
V-153	Refractory Metals Wet Air Pollution Control Blowdown	814

LIST OF TABLES (Continued)

<u>Table</u>	<u>Title</u>	<u>Page</u>
V-154	Refractory Metals Wet Air Pollution Control Blowdown Raw Wastewater Sampling Data	815
V-155	Titanium Rolling Spent Neat Oils	819
V-156	Titanium Rolling Contact Cooling Water	820
V-157	Titanium Drawing Spent Neat Oils	821
V-158	Titanium Extrusion Spent Neat Oils	822
V-159	Titanium Extrusion Spent Emulsions	823
V-160	Titanium Extrusion Press Hydraulic Fluid Leakage	824
V-161	Titanium Extrusion Press Hydraulic Fluid Leakage Raw Wastewater Sampling Data	825
V-162	Titanium Forging Spent Lubricants	826
V-163	Titanium Forging Contact Cooling Water	827
V-164	Titanium Forging Equipment Cleaning Wastewater	828
V-165	Titanium Forging Press Hydraulic Fluid Leakage	829
V-166	Titanium Tube Reducing Spent Lubricants	830
V-167	Titanium Tube Reducing Spent Lubricants Raw Wastewater Sampling Data	831
V-168	Titanium Heat Treatment Contact Cooling Water	832
V-169	Titanium Heat Treatment Contact Cooling Water Raw Wastewater Sampling Data	833
V-170	Titanium Surface Treatment Spent Baths	836

LIST OF TABLES (Continued)

<u>Table</u>	<u>Title</u>	<u>Page</u>
V-171	Titanium Surface Treatment Spent Baths Raw Wastewater Sampling Data	837
V-172	Titanium Surface Treatment Rinse	841
V-173	Titanium Surface Treatment Rinse Raw Wastewater Sampling Data	842
V-174	Titanium Alkaline Cleaning Spent Baths	847
V-175	Titanium Alkaline Cleaning Spent Baths Raw Wastewater Sampling Data	848
V-176	Titanium Alkaline Cleaning Rinse	850
V-177	Titanium Alkaline Cleaning Rinse Raw Wastewater Sampling Data	851
V-178	Titanium Molten Salt Rinse	853
V-179	Titanium Tumbling Wastewater	854
V-180	Titanium Tumbling Wastewater Raw Wastewater Sampling Data	855
V-181	Titanium Sawing or Grinding Spent Neat Oils	858
V-182	Titanium Sawing or Grinding Spent Emulsions	859
V-183	Titanium Sawing or Grinding Spent Emulsions Raw Wastewater Sampling Data	860
V-184	Titanium Sawing or Grinding Contact Cooling Water	865
V-185	Titanium Sawing or Grinding Contact Cooling Water Raw Wastewater Sampling Data	866
V-186	Titanium Dye Penetrant Testing Wastewater	867

LIST OF TABLES (Continued)

<u>Table</u>	<u>Title</u>	<u>Page</u>
V-187	Titanium Hydrotesting Wastewater	868
V-188	Titanium Wet Air Pollution Control Blowdown	869
V-189	Titanium Wet Air Pollution Control Blowdown Raw Wastewater Sampling Data	870
V-190	Uranium Extrusion Spent Lubricants	873
V-191	Uranium Extrusion Tool Contact Cooling Water	874
V-192	Uranium Forging Spent Lubricants	875
V-193	Uranium Heat Treatment Contact Cooling Water	876
V-194	Uranium Heat Treatment Contact Cooling Water Raw Wastewater Sampling Data	877
V-195	Uranium Surface Treatment Spent Baths	884
V-196	Uranium Surface Treatment Spent Baths Raw Wastewater Sampling Data	885
V-197	Uranium Surface Treatment Rinse	888
V-198	Uranium Surface Treatment Rinse Raw Wastewater Sampling Data	889
V-199	Uranium Sawing or Grinding Spent Emulsions	894
V-200	Uranium Sawing or Grinding Spent Emulsions Raw Wastewater Sampling Data	895
V-201	Uranium Sawing or Grinding Contact Cooling Water	898
V-202	Uranium Sawing or Grinding Rinse	899
V-203	Uranium Area Cleaning Washwater	900

LIST OF TABLES (Continued)

<u>Table</u>	<u>Title</u>	<u>Page</u>
V-204	Uranium Area Cleaning Washwater Raw Wastewater Sampling Data	901
V-205	Uranium Wet Air Pollution Control Blowdown	908
V-206	Uranium Wet Air Pollution Control Blowdown Raw Wastewater Sampling Data	909
V-207	Uranium Drum Washwater	911
V-208	Uranium Drum Washwater Raw Wastewater Sampling Data	913
V-209	Uranium Laundry Washwater	917
V-210	Uranium Laundry Washwater Raw Wastewater Sampling Data	918
V-211	Zinc Rolling Spent Neat Oils	921
V-212	Zinc Rolling Spent Emulsions	922
V-213	Zinc Rolling Contact Cooling Water	923
V-214	Zinc Drawing Spent Emulsions	924
V-215	Zinc Direct Chill Casting Contact Cooling Water	925
V-216	Zinc Stationary Casting Contact Cooling Water	926
V-217	Zinc Heat Treatment Contact Cooling Water	927
V-218	Zinc Surface Treatment Spent Baths	928
V-219	Zinc Surface Treatment Rinse	929
V-220	Zinc Surface Treatment Rinse Raw Wastewater Sampling Data	930

LIST OF TABLES (Continued)

<u>Table</u>	<u>Title</u>	<u>Page</u>
V-221	Zinc Alkaline Cleaning Spent Baths	935
V-222	Zinc Alkaline Cleaning Rinse	936
V-223	Zinc Alkaline Cleaning Rinse Raw Wastewater Sampling Data	937
V-224	Zinc Sawing or Grinding Spent Emulsions	942
V-225	Zinc Electrocoating Rinse	943
V-226	Zirconium-Hafnium Rolling Spent Neat Oils	944
V-227	Zirconium-Hafnium Drawing Spent Lubricants	945
V-228	Zirconium-Hafnium Extrusion Spent Lubricants	946
V-229	Zirconium-Hafnium Extrusion Press Hydraulic Fluid Leakage	947
V-230	Zirconium-Hafnium Extrusion Press Hydraulic Fluid Leakage Raw Wastewater Sampling Data	948
V-231	Zirconium-Hafnium Swaging Spent Neat Oils	949
V-232	Zirconium-Hafnium Tube Reducing Spent Lubricants	950
V-233	Zirconium-Hafnium Heat Treatment Contact, Cooling Water	951
V-234	Zirconium-Hafnium Heat Treatment Contact Cooling Water Raw Wastewater Sampling Data	952
V-235	Zirconium-Hafnium Surface Treatment Spent Baths	955
V-236	Zirconium-Hafnium Surface Treatment Spent Baths Raw Wastewater Sampling Data	956

LIST OF TABLES (Continued)

<u>Table</u>	<u>Title</u>	<u>Page</u>
V-237	Zirconium-Hafnium Surface Treatment Rinse	962
V-238	Zirconium-Hafnium Alkaline Cleaning Spent Baths	963
V-239	Zirconium-Hafnium Alkaline Cleaning Rinse	964
V-240	Zirconium-Hafnium Molten Salt Rinse	965
V-241	Zirconium-Hafnium Sawing or Grinding Spent Neat Oils	966
V-242	Zirconium-Hafnium Sawing or Grinding Spent Emulsions	967
V-243	Zirconium-Hafnium Sawing or Grinding Contact Cooling Water	968
V-244	Zirconium-Hafnium Sawing or Grinding Rinse	969
V-245	Zirconium-Hafnium Inspection and Testing Wastewater	970
V-246	Zirconium-Hafnium Inspection and Testing Wastewater Raw Wastewater Sampling Data	971
V-247	Zirconium-Hafnium Degreasing Spent Solvents	974
V-248	Zirconium-Hafnium Degreasing Rinse	975
V-249	Zirconium-Hafnium Wet Air Pollution Control Blowdown	976
V-250	Metal Powders Metal Powder Production Atomization Wastewater	977
V-251	Metal Powders Metal Powder Production Atomization Wastewater Raw Wastewater Sampling Data	978
V-252	Metal Powders Tumbling, Burnishing or Cleaning Wastewater	980

LIST OF TABLES (Continued)

<u>Table</u>	<u>Title</u>	<u>Page</u>
V-253	Metal Powders Tumbling, Burnishing or Cleaning Wastewater Raw Wastewater Sampling Data	982
V-254	Metal Powders Sawing or Grinding Spent Neat Oils	987
V-255	Metal Powders Sawing or Grinding Spent Emulsions	988
V-256	Metal Powders Sawing or Grinding Spent Emulsions Raw Wastewater Sampling Data	989
V-257	Metal Powders Sawing or Grinding Contact Cooling Water	993
V-258	Metal Powders Sawing or Grinding Contact Cooling Water Raw Wastewater Sampling Data	994
V-259	Metal Powders Sizing Spent Neat Oils	995
V-260	Metal Powders Sizing Spent Emulsions	996
V-261	Metal Powders Steam Treatment Wet Air Pollution Control Blowdown	997
V-262	Metal Powders Steam Treatment Wet Air Pollution Control Blowdown Raw Wastewater Sampling Data	998
V-263	Metal Powders Oil-Resin Impregnation Spent Neat Oils	1001
V-264	Metal Powders Hot Pressing Contact Cooling Water	1002
V-265	Metal Powders Hot Pressing Contact Cooling Water Raw Wastewater Sampling Data	1003
V-266	Metal Powders Mixing Wet Air Pollution Control Blowdown	1004

LIST OF TABLES (Continued)

<u>Table</u>	<u>Title</u>	<u>Page</u>
V-267	Metal Powders Mixing Wet Air Pollution Control Blowdown Raw Wastewater Sampling Data	1005
V-268	Wastewater Treatment Performance Data - Plant A	1006
V-269	Wastewater Treatment Performance Data - Plant B	1009
V-270	Wastewater Treatment Performance Data - Plant D	1013
V-271	Wastewater Treatment Performance Data - Plant E	1017
V-272	Wastewater Treatment Performance Data - Plant F	1025
V-273	Wastewater Treatment Performance Data - Plant I	1032
V-274	Wastewater Treatment Performance Data - Plant J	1038
V-275	Wastewater Treatment Performance Data - Plant M	1041
V-276	Wastewater Treatment Performance Data - Plant Q	1051
V-277	Wastewater Treatment Performance Data - Plant R	1060
V-278	Wastewater Treatment Performance Data - Plant S	1062
V-279	Wastewater Treatment Performance Data - Plant T	1064
V-280	Wastewater Treatment Performance Data - Plant U	1065
V-281	Wastewater Treatment Performance Data - Plant V	1072
V-282	Wastewater Treatment Performance Data - Plant W	1080

LIST OF TABLES (Continued)

<u>Table</u>	<u>Title</u>	<u>Page</u>
V-283	Wastewater Treatment Performance Data - Plant X	1084
V-284	Wastewater Treatment Performance Data - Plant Y	1089
V-285	Wastewater Treatment Performance Data - Plant Z	1094
VI-1	List of 129 Priority Pollutants	1245
VI-2	Analytical Quantification and Treatment Effectiveness Values	1251
VI-3	Priority Pollutant Disposition Lead-Tin-Bismuth Forming Subcategory	1255
VI-4	Priority Pollutant Disposition Magnesium Forming Subcategory	1259
VI-5	Priority Pollutant Disposition Nickel-Cobalt Forming Subcategory	1263
VI-6	Priority Pollutant Disposition Precious Metals Forming Subcategory	1273
VI-7	Priority Pollutant Disposition Refractory Metals Forming Subcategory	1280
VI-8	Priority Pollutant Disposition Titanium Forming Subcategory	1287
VI-9	Priority Pollutant Disposition Uranium Forming Subcategory	1294
VI-10	Priority Pollutant Disposition Zinc Forming Subcategory	1298
VI-11	Priority Pollutant Disposition Zirconium-Hafnium Forming Subcategory	1302
VI-12	Priority Pollutant Disposition Metal Powders Subcategory	1306

LIST OF TABLES (Continued)

<u>Table</u>	<u>Title</u>	<u>Page</u>
VII-1	pH Control Effect on Metals Removal	1400
VII-2	Effectiveness of Sodium Hydroxide for Metals Removal	1400
VII-3	Effectiveness of Lime and Sodium Hydroxide for Metals Removal	1401
VII-4	Theoretical Solubilities of Hydroxides and Sulfide of Selected Metals in Pure Water	1401
VII-5	Sampling Data From Sulfide Precipitation-Sedimentation Systems	1402
VIII-6	Sulfide Precipitation-Sedimentation Performance	1403
VII-7	Ferrite Co-Precipitation Performance	1404
VII-8	Concentration of Total Cyanide	1404
VII-9	Multimedia Filter Performance	1405
VII-10	Performance of Selected Settling Systems	1405
VII-11	Skimming Performance	1406
VII-12	Selected Partition Coefficients	1407
VII-13	Trace Organic Removal by Skimming	1408
VII-14	Combined Metals Data Effluent Values	1408
VII-15	L & S Performance Additional Pollutants	1409
VII-16	Combined Metals Data Set - Untreated Wastewater	1409
VII-17	Maximum Pollutant Level in Untreated Wastewater Additional Pollutants	1410

LIST OF TABLES (Continued)

<u>Table</u>	<u>Title</u>	<u>Page</u>
VII-18	Precipitation-Settling-Filtration (LS&F) Performance Plant A	1411
VII-19	Precipitation-Settling-Filtration (LS&F) Performance Plant B	1412
VII-20	Precipitation-Settling-Filtration (LS&F) Performance Plant C	1413
VII-21	Summary of Treatment Effectiveness	1414
VII-22	Summary of Treatment Effectiveness for Selected Nonconventional Pollutants	1415
VII-23	Treatability Rating of Priority Pollutants	1416
VII-24	Classes of Organic Compounds Adsorbed on Carbon	1417
VII-25	Activated Carbon Performance (Mercury)	1418
VII-26	Ion Exchange Performance	1418
VII-27	Membrane Filtration System Effluent	1419
VII-28	Peat Adsorption Performance	1419
VII-29	Ultrafiltration Performance	1420
VII-30	Chemical Emulsion Breaking Efficiencies	1421
VIII-1	BPT Costs of Compliance for the Nonferrous Metals Forming Category	1508
VIII-2	BAT Costs of Compliance for the Nonferrous Metals Forming Category	1509
VIII-3	PSES Costs of Compliance for the Nonferrous Metals Forming Category	1510

LIST OF TABLES (Continued)

<u>Table</u>	<u>Title</u>	<u>Page</u>
VIII-4	Nonferrous Metals Forming Category. Cost Equations for Recommended Treatment and Control Technologies	1511
VIII-5	Components of Total Capital Investment	1518
VIII-6	Components of Total Annualized Investment	1519
VIII-7	Wastewater Sampling Frequency	1520
VIII-8	Pollutant Parameter Important to Treatment System Design	1521
VIII-9	Sludge to Influent Flow Ratios	1522
VIII-10	Key to Cost Curves and Equations	1523
VIII-11	Cost Equations Used in Cost Curve Method	1524
VIII-12	Number of Plants for Which Costs Were Scaled From Similar Plants	1525
VIII-13	Flow Reduction Recycle Ratio and Association Cost Assumptions	1526
VIII-14	Segregation Cost Basis	1528
VIII-15	Nonferrous Metals Forming Solid Waste Generation	1529
VIII-16	Nonferrous Metals Forming Energy Consumption	1530
IX-1	Potential Preliminary Treatment Requirements Lead-Tin-Bismuth Forming Subcategory	1626
IX-2	Potential Preliminary Treatment Requirements Magnesium Forming Subcategory	1627

LIST OF TABLES (Continued)

<u>Table</u>	<u>Title</u>	<u>Page</u>
IX-3	Potential Preliminary Treatment Requirements Nickel-Cobalt Forming Subcategory	1628
IX-4	Potential Preliminary Treatment Requirements Precious Metals Forming Subcategory	1630
IX-5	Potential Preliminary Treatment Requirements Refractory Metals Forming Subcategory	1631
IX-6	Potential Preliminary Treatment Requirements Titanium Forming Subcategory	1633
IX-7	Potential Preliminary Treatment Requirements Uranium Forming Subcategory	1635
IX-8	Potential Preliminary Treatment Requirements Zinc Forming Subcategory	1636
IX-9	Potential Preliminary Treatment Requirements Zirconium-Hafnium Forming Subcategory	1637
IX-10	Potential Preliminary Treatment Requirements Metal Powders Subcategory	1638
IX-11	BPT Regulatory Flows for Production Operations - Lead-Tin-Bismuth Forming Subcategory	1639
IX-12	Lead-Tin-Bismuth Forming Subcategory BPT Effluent Limitations	1641
IX-13	BPT Regulatory Flows for Production Operations - Magnesium Forming Subcategory	1648
IX-14	Magnesium Forming Subcategory BPT Effluent Limitations	1649

LIST OF TABLES (Continued)

<u>Table</u>	<u>Title</u>	<u>Page</u>
IX-15	BPT Regulatory Flows for Production Operations - Nickel-Cobalt Forming Subcategory	1653
IX-16	Nickel-Cobalt Forming Subcategory BPT Effluent Limitations	1656
IX-17	BPT Regulatory Flows for Production Operations - Precious Metals Forming Subcategory	1670
IX-18	Precious Metals Forming Subcategory BPT Effluent Limitations	1672
IX-19	BPT Regulatory Flows for Production Operations - Refractory Metals Forming Subcategory	1682
IX-20	Refractory Metals Forming Subcategory BPT Effluent Limitations	1684
IX-21	BPT Regulatory Flows for Production Operations - Titanium Forming Subcategory	1701
IX-22	Titanium Forming Subcategory BPT Effluent Limitations	1703
IX-23	BPT Regulatory Flows for Production Operations - Uranium Forming	1715
IX-24	Uranium Forming Subcategory BPT Effluent Limitations	1717
IX-25	BPT Regulatory Flows for Production Operations - Zinc Forming Subcategory	1724
IX-26	Zinc Forming Subcategory BPT Effluent Limitations	1725
IX-27	BPT Regulatory Flows for Production Operations - Zirconium-Hafnium Forming Subcategory	1731
IX-28	Zirconium-Hafnium Forming Subcategory BPT Effluent Limitations	1733

LIST OF TABLES (Continued)

<u>Table</u>	<u>Title</u>	<u>Page</u>
IX-29	BPT Regulatory Flows for Production Operations - Metal Powders Subcategory	1741
IX-30	Metal Powders Subcategory BPT Effluent Limitations	1742
IX-31	Allowable Discharge Calculations for Refractory Metals Forming Plant X in Example 1 (Nickel)	1748
IX-32	Allowable Discharge Calculations for Lead-Tin-Bismuth Forming Plant Y in Example 2 (Total Suspended Solids)	1749
IX-33	Allowable Discharge Calculations for Nickel-Cobalt and Titanium Forming Plant Z in Example 3 (Nickel)	1751
IX-34	Allowable Discharge Calculations for Nickel-Cobalt and Titanium Forming Plant Z in Example 3 (Cyanide)	1753
X-1	Capital and Annual Cost Estimates for BAT (PSES) Total Subcategory	1794
X-2	Capital and Annual Cost Estimates for BAT Direct Dischargers	1795
X-3	Nonferrous Metals Forming Pollutant Reduction Benefit Estimates Lead-Tin-Bismuth Forming Subcategory Total Subcategory	1796
X-4	Nonferrous Metals Forming Pollutant Reduction Benefit Estimates Magnesium Forming Subcategory Total Subcategory	1797
X-5	Nonferrous Metals Forming Pollutant Reduction Benefit Estimates Nickel-Cobalt Forming Subcategory Total Subcategory	1798

LIST OF TABLES (Continued)

<u>Table</u>	<u>Title</u>	<u>Page</u>
X-6	Nonferrous Metals Forming Pollutant Reduction Benefit Estimates Precious Metals Forming Subcategory Total Subcategory	1799
X-7	Nonferrous Metals Forming Pollutant Reduction Benefit Estimates Refractory Metals Forming Subcategory Total Subcategory	1800
X-8	Nonferrous Metals Forming Pollutant Reduction Benefit Estimates Titanium Forming Subcategory Total Subcategory	1801
X-9	Nonferrous Metals Forming Pollutant Reduction Benefit Estimates Uranium Forming Subcategory Total Subcategory	1802
X-10	Nonferrous Metals Forming Pollutant Reduction Benefit Estimates Zinc Forming Subcategory Total Subcategory	1803
X-11	Nonferrous Metals Forming Pollutant Reduction Benefit Estimates Zirconium-Hafnium Forming Subcategory Total Subcategory	1804
X-12	Nonferrous Metals Forming Pollutant Reduction Benefit Estimates Metal Powders Subcategory Total Subcategory	1805
X-13	Nonferrous Metals Forming Pollutant Reduction Benefit Estimates Lead- Tin-Bismuth Forming Subcategory Direct Dischargers	1806
X-14	Nonferrous Metals Forming Pollutant Reduction Benefit Estimates Magnesium Forming Subcategory Direct Dischargers	1807

LIST OF TABLES (Continued)

<u>Table</u>	<u>Title</u>	<u>Page</u>
X-15	Nonferrous Metals Forming Pollutant Reduction Benefit Estimates Nickel- Cobalt Forming Subcategory Direct Dischargers	1808
X-16	Nonferrous Metals Forming Pollutant Reduction Benefit Estimates Precious Metals Forming Subcategory Direct Dischargers	1809
X-17	Nonferrous Metals Forming Pollutant Reduction Benefit Estimates Refractory Metals Forming Subcategory Direct Dischargers	1810
X-18	Nonferrous Metals Forming Pollutant Reduction Benefit Estimates Titanium Forming Subcategory Direct Dischargers	1811
X-19	Nonferrous Metals Forming Pollutant Reduction Benefit Estimates Uranium Forming Subcategory Direct Dischargers	1812
X-20	Nonferrous Metals Forming Pollutant Reduction Benefit Estimates Zinc Forming Subcategory	1813
X-21	Nonferrous Metals Forming Pollutant Reduction Estimates Zirconium- Hafnium Forming Direct Dischargers	1814
X-22	Nonferrous Metals Forming Pollutant Reduction Estimates Metal Powders Subcategory Direct Dischargers	1815
X-23	Options Selected as the Technology Basis for BAT	1816
X-24	BAT Regulatory Flows for the Produc- tion Operations - Lead-Tin-Bismuth Forming Subcategory	1817

LIST OF TABLES (Continued)

<u>Table</u>	<u>Title</u>	<u>Page</u>
X-25	Lead-Tin-Bismuth Forming Subcategory BAT Effluent Limitations	1819
X-26	BAT Regulatory Flows for the Produc- tion Operations - Magnesium Forming Subcategory	1824
X-27	Magnesium Forming Subcategory BAT Effluent Limitations	1825
X-28	BAT Regulatory Flows for the Produc- tion Operations - Nickel-Cobalt Forming Subcategory	1829
X-29	Nickel-Cobalt Forming Subcategory BAT Effluent Limitations	1832
X-30	BAT Regulatory Flows for the Production Operations - Precious Metal Forming Subcategory	1845
X-31	Precious Metals Forming Subcategory BAT Effluent Limitations	1847
X-32	BAT Regulatory Flows for the Production Operations - Refractory Metals Forming Subcategory	1856
X-33	Refractory Metals Forming Subcate- gory BAT Effluent Limitations	1858
X-34	BAT Regulatory Flows for the Production Operations - Titanium Forming Subcategory	1869
X-35	Titanium Forming Subcategory BAT Effluent Limitations	1871
X-36	BAT Regulatory Flows for the Production Operations - Uranium Forming Subcategory	1882

LIST OF TABLES (Continued)

<u>Table</u>	<u>Title</u>	<u>Page</u>
X-37	Uranium Forming Subcategory BAT Effluent Limitations	1884
X-38	BAT Regulatory Flows for the Production Operations - Zinc Forming Subcategory	1889
X-39	Zinc Forming Subcategory BAT Effluent Limitations	1890
X-40	BAT Regulatory Flows for the Production Operations - Zirconium-Hafnium Forming Subcategory	1896
X-41	Zirconium-Hafnium Forming Subcategory BAT Effluent Limitations	1898
X-42	BAT Regulatory Flows for the Production Operations - Metal Powders Subcategory	1906
X-43	Metal Powders Subcategory BAT Effluent Limitations	1907
XI-1	Options Selected as the Bases for NSPS	1919
XI-2	Lead-Tin-Bismuth Forming Subcategory New Source Performance Standards	1920
XI-3	Magnesium Forming Subcategory New Source Performance Standards	1927
XI-4	Nickel-Cobalt Forming Subcategory New Source Performance Standards	1931
XI-5	Precious Metals Forming Subcategory New Source Performance Standards	1946
XI-6	Refractory Metals Forming Subcategory New Source Performance Standards	1956
XI-7	Titanium Forming Subcategory New Source Performance Standards	1973

LIST OF TABLES (Continued)

<u>Table</u>	<u>Title</u>	<u>Page</u>
XI-8	Uranium Forming Subcategory New Source Performance Standards	1986
XI-9	Zinc Forming Subcategory New Source Performance Standards	1993
XI-10	Zirconium-Hafnium Forming Subcategory New Source Performance Standards	1999
XI-11	Metal Powders Subcategory New Source Performance Standards	2006
XII-1	POTW Removals of the Toxic Pollutants Found in Nonferrous Metals Forming Wastewater	2019
XII-2	Pollutant Removal Percentages for BAT or PSES Model Technology By Subcategory	2021
XII-3	Option Selected as the Model Technology Basis for PSES and PSNS	2022
XII-4	Capital and Annual Cost Estimates for PSES Options Indirect Dischargers	2023
XII-5	Nonferrous Metals Forming Pollutant Reduction Benefit Estimates Lead-Tin-Bismuth Forming Subcategory Indirect Dischargers	2025
XII-6	Nonferrous Metals Forming Pollutant Reduction Benefit Estimates Magnesium Forming Subcategory Indirect Dischargers	2026
XII-7	Nonferrous Metals Forming Pollutant Reduction Benefit Estimates Nickel-Cobalt Forming Subcategory Indirect Dischargers	2027

LIST OF TABLES (Continued)

<u>Table</u>	<u>Title</u>	<u>Page</u>
XII-8	Nonferrous Metals Forming Pollutant 2028 Reduction Benefit Estimates Precious Metals Forming Subcategory Indirect Dischargers	
XII-9	Nonferrous Metals Forming Pollutant 2029 Reduction Benefit Estimates Refractory Metals Forming Subcategory Indirect Dischargers	
XII-10	Nonferrous Metals Forming Pollutant 2030 Reduction Benefit Estimates Titanium Forming Subcategory Indirect Dischargers	
XII-11	Nonferrous Metals Forming Pollutant 2031 Reduction Benefit Estimates Zirconium-Hafnium Forming Subcategory Indirect Dischargers	
XII-12	Nonferrous Metals Forming Pollutant 2032 Reduction Benefit Estimates Metal Powders Subcategory Indirect Dischargers	
XII-13	Lead-Tin-Bismuth Forming Subcategory 2033 Pretreatment Standards for Existing Sources	
XII-14	Magnesium Forming Subcategory Pretreatment Standards for Existing Sources	2038
XII-15	Nickel-Cobalt Forming Subcategory Pretreatment Standards for Existing Sources	2042
XII-16	Precious Metals Forming Subcategory Pretreatment Standards for Existing Sources	2055
XII-17	Refractory Metals Forming Subcate- gory Pretreatment Standards for Existing Sources	2064

LIST OF TABLES (Continued)

<u>Table</u>	<u>Title</u>	<u>Page</u>
XII-18	Titanium Forming Subcategory Pretreatment Standards for Existing Sources	2075
XII-19	Uranium Forming Subcategory Pretreatment Standards for Existing Sources	2085
XII-20	Zinc Forming Subcategory Pretreatment Standards for Existing Sources	2091
XII-21	Zirconium-Hafnium Forming Subcategory Pretreatment Standards for Existing Sources	2097
XII-22	Metal Powders Subcategory Pretreatment Standards for Existing Sources	2105
XII-23	Lead-Tin-Bismuth Forming Subcategory Pretreatment Standards for New Sources	2110
XII-24	Magnesium Forming Subcategory Pretreatment Standards for New Sources	2115
XII-25	Nickel-Cobalt Forming Subcategory Pretreatment Standards for New Sources	2119
XII-26	Precious Metals Forming Subcategory Pretreatment Standards for New Sources	2132
XII-27	Refractory Metals Forming Subcategory Pretreatment Standards for New Sources	2141
XII-28	Titanium Forming Subcategory Pretreatment Standards for New Sources	2152

LIST OF TABLES (Continued)

<u>Table</u>	<u>Title</u>	<u>Page</u>
XII-29	Uranium Forming Subcategory Pretreatment Standards for New Sources	2162
XII-30	Zinc Forming Subcategory Pretreatment Standards for New Sources	2168
XII-31	Zirconium-Hafnium Forming Subcategory Pretreatment Standards for New Sources	2174
XII-32	Metal Powders Subcategory Pretreatment Standards for New Sources	2182

LIST OF FIGURES

<u>Figure</u>	<u>Title</u>	<u>Page</u>
III-1	Geographical Distribution of Nonferrous Forming Plants	360
III-2	Sequence of Nonferrous Metals Forming Operations	361
III-3	Common Rolling Mill Configurations	362
III-4	Reversing Hot Strip Mill	363
III-5	4-High Cold Rolling Mill	364
III-6	Tube Drawing	365
III-7	Hydraulic Draw Bench	366
III-8	Direct Extrusion	367
III-9	Extrusion Press	368
III-10	Extrusion Tooling and Setup	369
III-11	Forging	370
III-12	Ring Rolling	371
III-13	Impacting	372
III-14	Some Clad Configurations	373
III-15	Atomization	374
III-16	Powder Metallurgy Die Compaction	375
III-17	Direct Chill Casting	376
III-18	Direct Chill (D.C.) Casting Unit	377
III-19	Continuous Sheet Casting	378
III-20	Continuous Strip Casting	379
III-21	Shot Casting	380
III-22	Roller Hearth Annealing Furnace	381
III-23	Bulk Pickling Tank	382
III-24	Continuous Pickling Line	383

LIST OF FIGURES (Continued)

<u>Figure</u>	<u>Title</u>	<u>Page</u>
III-25	Vapor Degreaser	384
V-1	Wastewater Sources at Plant A	1098
V-2	Wastewater Sources at Plant B	1099
V-3	Wastewater Sources at Plant C	1100
V-4	Wastewater Sources at Plant D	1101
V-5	Wastewater Sources at Plant E	1102
V-6	Wastewater Sources at Plant F	1103
V-7	Wastewater Sources at Plant G	1104
V-8	Wastewater Sources at Plant I	1105
V-9	Wastewater Sources at Plant J	1106
V-10	Wastewater Sources at Plant K	1107
V-11	Wastewater Sources at Plant L	1108
V-12	Wastewater Sources at Plant M	1109
V-13	Wastewater Sources at Plant N	1110
V-14	Wastewater Sources at Plant O	1111
V-15	Wastewater Sources at Plant P	1112
V-16	Wastewater Sources at Plant Q	1113
V-17	Wastewater Sources at Plant R	1114
V-18	Wastewater Sources at Plant S	1115
V-19	Wastewater Sources at Plant T	1116
V-20	Wastewater Sources at Plant V	1117
V-21	Wastewater Sources at Plant Z	1118

LIST OF FIGURES (Continued)

<u>Figure</u>	<u>Title</u>	<u>Page</u>
VII-1	Comparative Solubilities of Metal Hydroxides and Sulfide as a Function of pH	1422
VII-2	Lead Solubility in Three Alkalies	1423
VII-3	Effluent Zinc Concentrations vs. Minimum Effluent pH	1424
VII-4	Hydroxide Precipitation Sedimentation Effectiveness - Cadmium	1425
VII-5	Hydroxide Precipitation Sedimentation Effectiveness - Chromium	1426
VII-6	Hydroxide Precipitation Sedimentation Effectiveness - Copper	1427
VII-7	Hydroxide Precipitation Sedimentation Effectiveness - Lead	1428
VII-8	Hydroxide Precipitation Sedimentation Effectiveness - Nickel and Aluminum	1429
VII-9	Hydroxide Precipitation Sedimentation Effectiveness - Zinc	1430
VII-10	Hydroxide Precipitation Sedimentation Effectiveness - Iron	1431
VII-11	Hydroxide Precipitation Sedimentation Effectiveness - Manganese	1432
VII-12	Hydroxide Precipitation Sedimentation Effectiveness - TSS	1433
VII-13	Hexavalent Chromium Reduction with Sulfur Dioxide	1434
VII-14	Granular Bed Filtration	1435
VII-15	Pressure Filtration	1436
VII-16	Representative Types of Sedimentation	1437
VII-17	Activated Carbon Adsorption Column	1438
VII-18	Centrifugation	1439

LIST OF FIGURES (Continued)

<u>Figure</u>	<u>Title</u>	<u>Page</u>
VII-19	Treatment of Cyanide Waste by Alkaline Chlorination	1440
VII-20	Typical Ozone Plant for Waste Treatment	1441
VII-21	UV/Ozonation	1442
VII-22	Types of Evaporation Equipment	1443
VII-23	Dissolved Air Flotation	1444
VII-24	Gravity Thickening	1445
VII-25	Ion Exchange with Regeneration	1446
VII-26	Simplified Reverse Osmosis Schematic	1447
VII-27	Reverse Osmosis Membrane Configurations	1448
VII-28	Sludge Drying Bed	1449
VII-29	Simplified Ultrafiltration Flow Schematic	1450
VII-30	Vacuum Filtration	1451
VII-31	Flow Diagram for Emulsion Breaking with Chemicals	1452
VII-32	Filter Configurations	1453
VII-33	Gravity Oil/Water Separator	1454
VII-34	Flow Diagram for a Batch Treatment Ultrafiltration System	1455
VII-35	Flow Diagram of Activated Carbon Adsorption with Regeneration	1456
VII-36	Flow Diagram for Recycling with a Coolint Tower	1457
VII-37	Countercurrent Rinsing (Tanks)	1458
VII-38	Effect of Added Rinse Stages on Water Use	1459

LIST OF FIGURES (Continued)

<u>Figure</u>	<u>Title</u>	<u>Page</u>
VIII-1	General Logic Diagram of Computer Cost Model	1531
VIII-2	Logic Diagram of Module Design Procedure	1532
VIII-3	Logic Diagram of the Cost Estimation Routine	1533
VIII-4	Capital Cost of a Spray Rinsing System	1534
VIII-5	Capital and Annual Costs of Aerated Rectangular Fiberglass Tanks	1535
VIII-6	Capital and Annual Costs of Centrifugal Pumps	1536
VIII-7	Capital and Annual Costs of Cooling Towers and Holding Tank	1537
VIII-8	Capital and Annual Costs of Holding Tanks and Recycle Piping	1538
VIII-9	Capital and Annual Costs of Equalization	1539
VIII-10	Capital and Annual Costs of Cyanide Precipitation	1540
VIII-11	Capital and Annual Costs of Chromium Reduction	1541
VIII-12	Capital Costs of Iron Coprecipitation	1542
VIII-13	Annual Costs of Iron Coprecipitation	1543
VIII-14	Capital and Annual Costs of Chemical Emulsion Breaking	1544
VIII-15	Capital and Annual Costs of Ammonia Steam Stripping	1545
VIII-16	Capital and Annual Costs of Chemical Precipitation	1546
VIII-17	Capital Costs for Carbon Steel Vacuum Filters	1547

LIST OF FIGURES (Continued)

<u>Figure</u>	<u>Title</u>	<u>Page</u>
VIII-18	Capital Costs for Stainless Steel Vacuum Filters	1548
VIII-19	Annual Costs for Vacuum Filters	1549
VIII-20	Capital and Annual Costs for Multi-media and Cartridge Filtration	1550
VIII-21	Annual Costs for Contract Hauling	1551
XI-1	BPT Treatment Train for the Non-ferrous Metals Forming Category	1755
X-1	BAT Option 1 and 2 Treatment Train for the Nonferrous Metals Forming Category	1912
X-2	BAT Option 3 Treatment Train for the Nonferrous Metals Forming Category	1913

SECTION VII

CONTROL AND TREATMENT TECHNOLOGY

This section describes the treatment techniques currently used or available to remove or recover wastewater pollutants normally generated by the nonferrous metals forming and metal powders industrial point source category (hereafter referred to as nonferrous metals forming). Included are discussions of individual end-of-pipe treatment technologies and in-plant technologies. These treatment technologies are widely used in many industrial categories, and data and information to support their effectiveness has been drawn from a similarly wide range of sources and data bases.

END-OF-PIPE TREATMENT TECHNOLOGIES

Individual recovery and treatment technologies are described which are used or are suitable for use in treating wastewater discharges from nonferrous metals forming plants. Each description includes a functional description and discussion of application and performance, advantages and limitations, operational factors (reliability, maintainability, solid waste aspects), and demonstration status. The treatment processes described include both technologies presently demonstrated within the category, and technologies demonstrated in treatment of similar wastes in other industries.

Nonferrous metals forming wastewaters characteristically may be acid or alkaline; may contain substantial levels of dissolved or particulate metals including cadmium, chromium, copper, lead, nickel, silver, and zinc; may contain substantial levels of cyanide, ammonia and fluoride; may contain only small or trace amounts of toxic organics; and are generally free from strong chelating agents. The toxic inorganic pollutants constitute the most significant wastewater pollutants in this category. Oils and emulsions are also present in waste streams emanating from forming operations using neat and emulsified oil lubricants. Ammonia is present in wastewater discharges associated with some surface treatment operations.

In general, these pollutants are removed by oil removal (skimming and emulsion breaking), ammonia steam stripping, hexavalent chromium reduction, chemical precipitation and sedimentation or filtration. Most of them may be effectively removed by precipitation of metal hydroxides or carbonates utilizing the reaction with lime, sodium hydroxide, or sodium carbonate. For some, improved removals are provided by the use of sodium sulfide or ferrous sulfide to precipitate the pollutants as sulfide compounds with very low solubilities.

Discussion of end-of-pipe treatment technologies is divided into three parts: the major technologies; the effectiveness of major technologies; and minor end-of-pipe technologies.

MAJOR TECHNOLOGIES

In Sections IX, X, XI, and XII the rationale for selecting treatment systems is discussed. The individual technologies used in the system are described here. The major end-of-pipe technologies for treating nonferrous metals forming wastewaters are: (1) chemical reduction of chromium, (2) chemical precipitation, (3) cyanide precipitation, (4) granular bed filtration, (5) pressure filtration, (6) settling, and (7) skimming. In practice, precipitation of metals and settling of the resulting precipitates is often a unified two-step operation. Suspended solids originally present in raw wastewaters are not appreciably affected by the precipitation operation and are removed with the precipitated metals in the settling operations. Settling operations can be evaluated independently of hydroxide or other chemical precipitation operations, but hydroxide and other chemical precipitation operations can only be evaluated in combination with a solids removal operation.

1. Chemical Reduction of Chromium

Description of the Process. Reduction is a chemical reaction in which electrons are transferred to the chemical being reduced from the chemical initiating the transfer (the reducing agent). Sulfur dioxide, sodium bisulfite, sodium metabisulfite, and ferrous sulfate form strong reducing agents in aqueous solution and are often used in industrial waste treatment facilities for the reduction of hexavalent chromium to the trivalent form. The reduction allows removal of chromium from solution in conjunction with other metallic salts by alkaline precipitation. Hexavalent chromium is not precipitated as the hydroxide.

Gaseous sulfur dioxide is a widely used reducing agent and provides a good example of the chemical reduction process. Reduction using other reagents is chemically similar. The reactions involved may be illustrated as follows:

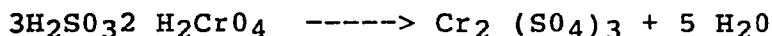
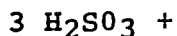

The above reaction is favored by low pH. A pH of from 2 to 3 is normal for situations requiring complete reduction. At pH levels above 5, the reduction rate is slow. Oxidizing agents such as dissolved oxygen and ferric iron interfere with the reduction process by consuming the reducing agent.

A typical treatment consists of 45 minutes retention in a reaction tank. The reaction tank has an electronic recorder-controller device to control process conditions with respect to pH and oxidation reduction potential (ORP). Gaseous sulfur dioxide is metered to the reaction tank to maintain the ORP within the range of 250 to 300 millivolts. Sulfuric acid is added to maintain a pH level of from 1.8 to 2.0. The reaction tank is equipped with a propeller agitator designed to provide approximately one turnover per minute. Figure VII-13 shows a continuous chromium reduction system.

Application and Performance. Chromium reduction is used in nonferrous metals forming for treating chromium containing wastewaters such as surface treatment baths and rinses. A study of an operational waste treatment facility chemically reducing hexavalent chromium has shown that a 99.7 percent reduction efficiency is easily achieved. Final concentrations of 0.05 mg/l are readily attained, and concentrations of 0.01 mg/l are considered to be attainable by properly maintained and operated equipment.

Advantages and Limitations. The major advantage of chemical reduction to reduce hexavalent chromium is that it is a fully proven technology based on many years of experience. Operation at ambient conditions results in minimal energy consumption, and the process, especially when using sulfur dioxide, is well suited to automatic control. Furthermore, the equipment is readily obtainable from many suppliers, and operation is straightforward.

One limitation of chemical reduction of hexavalent chromium is that for high concentrations of chromium, the cost of treatment chemicals may be prohibitive. When this situation occurs, other treatment techniques are likely to be more economical. Chemical interference by oxidizing agents is possible in the treatment of mixed wastes, and the treatment itself may introduce pollutants if not properly controlled. Storage and handling of sulfur dioxide is somewhat hazardous.

Operational Factors. Reliability: Maintenance consists of periodic removal of sludge, the frequency of removal depends on the input concentrations of detrimental constituents.

Solid Waste Aspects: Pretreatment to eliminate substances which will interfere with the process may often be necessary. This process produces trivalent chromium which can be controlled by further treatment. However, small amounts of sludge may be collected as the result of minor shifts in the solubility of the contaminants. This sludge can be processed by the main sludge treatment equipment.

Demonstration Status. The reduction of chromium waste by sulfur dioxide or sodium bisulfite is a classic process and is used by numerous plants which have hexavalent chromium compounds in wastewaters from operations such as electroplating conversion

coating and noncontact cooling. Six nonferrous metals forming plants reported the use of hexavalent chromium reduction to treat chromium containing wastewaters.

2. Chemical Precipitation

Dissolved toxic metal ions and certain anions may be chemically precipitated for removal by physical means such as sedimentation, filtration, or centrifugation. Several reagents are commonly used to effect this precipitation:

1) Alkaline compounds such as lime or sodium hydroxide may be used to precipitate many toxic metal ions as metal hydroxides. Lime also may precipitate phosphates as insoluble calcium phosphate, fluorides as calcium fluoride, and arsenic as calcium arsenate.

2) Both "soluble" sulfides such as hydrogen sulfide or sodium sulfide and "insoluble" sulfides such as ferrous sulfide may be used to precipitate many heavy metal ions as metal sulfides.

3) Ferrous sulfate, zinc sulfate or both (as is required) may be used to precipitate cyanide as a ferro or zinc ferricyanide complex.

4) Carbonate precipitates may be used to remove metals either by direct precipitation using a carbonate reagent such as calcium carbonate or by converting hydroxides into carbonates using carbon dioxide.

These treatment chemicals may be added to a flash mixer or rapid mix tank, to a presettling tank, or directly to a clarifier or other settling device. Because metal hydroxides tend to be colloidal in nature, coagulating agents may also be added to facilitate settling. After the solids have been removed, final pH adjustment may be required to reduce the high pH created by the alkaline treatment chemicals.

Chemical precipitation as a mechanism for removing metals from wastewater is a complex process of at least two steps - precipitation of the unwanted metals and removal of the precipitate. Some very small amount of metal will remain dissolved in the wastewater after precipitation is complete. The amount of residual dissolved metal depends on the treatment chemicals used and related factors. The effectiveness of this method of removing any specific metal depends on the fraction of the specific metal in the raw waste (and hence in the precipitate) and the effectiveness of suspended solids removal. In specific instances, a sacrificial ion such as iron or aluminum may be added to aid in the removal of toxic metals by co-precipitation.

Application and Performance. Chemical precipitation is used in nonferrous metals forming for precipitation of dissolved metals. It can be used to remove metal ions such as antimony,

arsenic, beryllium, cadmium, chromium, copper, lead, mercury, nickel, selenium, silver, zinc, aluminum, cobalt, columbium, gold, hafnium, iron, manganese, molybdenum, tantalum, tin, tungsten, vanadium and zirconium. The process is also applicable to any substance that can be transformed into an insoluble form such as fluorides, phosphates, soaps, sulfides and others. Because it is simple and effective, chemical precipitation is extensively used for industrial waste treatment.

The performance of chemical precipitation depends on several variables. The more important factors affecting precipitation effectiveness are:

1. Maintenance of an appropriate (usually alkaline) pH throughout the precipitation reaction and subsequent settling;
2. Addition of a sufficient excess of treatment ions to drive the precipitation reaction to completion;
3. Addition of an adequate supply of sacrificial ions (such as iron or aluminum) to ensure precipitation and removal of specific target ions; and
4. Effective removal of precipitated solids (see appropriate solids removal technologies).

Control of pH. Irrespective of the solids removal technology employed, proper control of pH is absolutely essential for favorable performance of precipitation-sedimentation technologies. This is clearly illustrated by solubility curves for selected metals hydroxides and sulfides shown in Figure VII-1 and by plotting effluent zinc concentrations against pH as shown in Figure VII-3. Figure VII-3 was obtained from Development Document for the Proposed Effluent Limitations Guidelines and New Source Performance Standards for the Zinc Segment of Nonferrous Metals Manufacturing Point Source Category, U.S. E.P.A., EPA 440/1-74/033, November, 1974. Figure VII-3 was plotted from the sampling data from several facilities with metal finishing operations. It is partially illustrated by data obtained from 3 consecutive days of sampling at one metal processing plant (47432) as displayed in Table VII-1. Flow through this system is approximately 49,263 l/hr (13,000 gal/hr).

This treatment system uses lime precipitation (pH adjustment) followed by coagulant addition and sedimentation. Samples were taken before (in) and after (out) the treatment system. The best treatment for removal of copper and zinc was achieved on day one, when the pH was maintained at a satisfactory level. The poorest treatment was found on the second day, when the pH slipped to an unacceptably low level; intermediate values were achieved on the third day, when pH values were less than desirable but in between those for the first and second days.

Sodium hydroxide is used by another facility (plant 439) for pH adjustment and chemical precipitation, followed by settling (sedimentation and a polishing lagoon) of precipitated solids. Samples were taken prior to caustic addition and following the polishing lagoon. Flow through the system is approximately 22,700 l/hr (6,000 gal/hr). These data displayed in Table VII-2 indicate that the system was operated efficiently. Effluent pH was controlled within the range of 8.6 to 9.3, and, while raw waste loadings were not unusually high, most toxic metals were removed to very low concentrations.

Lime and sodium hydroxide (combined) are sometimes used to precipitate metals. Data developed from plant 40063, a facility with a metal bearing wastewater, exemplify efficient operation of a chemical precipitation and settling system. Table VII-3 shows sampling data from this system, which uses lime and sodium hydroxide for pH adjustment, chemical precipitation, polyelectrolyte flocculant addition, and sedimentation. Samples were taken of the raw waste influent to the system and of the clarifier effluent. Flow through the system is approximately 19,000 l/hr (5,000 gal/hr).

At this plant, effluent TSS levels were below 15 mg/l on each day, despite average raw waste TSS concentrations of over 3500 mg/l. Effluent pH was maintained at approximately 8, lime addition was sufficient to precipitate the dissolved metal ions, and the flocculant addition and clarifier retention served to remove effectively the precipitated solids.

Sulfide precipitation is sometimes used to precipitate metals resulting in improved metals removals. Most metal sulfides are less soluble than hydroxides, and the precipitates are frequently more dependably removed from water. Solubilities for selected metal hydroxide, carbonate and sulfide precipitates are shown in Table VII-4. (Source: Lange's Handbook of Chemistry). Sulfide precipitation is particularly effective in removing specific metals such as silver and mercury. Sampling data from three industrial plants using sulfide precipitation appear in Table VII-5. In all cases except iron, effluent concentrations are below 0.1 mg/l and in many cases below 0.01 mg/l for the three plants studied.

Sampling data from several chlorine-caustic manufacturing plants using sulfide precipitation demonstrate effluent mercury concentrations varying between 0.009 and 0.03 mg/l. As shown in Figure VII-1, the solubilities of PbS and Ag₂S are lower at alkaline pH levels than either the corresponding hydroxides or other sulfide compounds. This implies that removal performance for lead and silver sulfides should be comparable to or better than that for the metal hydroxides. Bench scale tests on several types of metal finishing and manufacturing wastewater indicate that metals removal to levels of less than 0.05 mg/l and in some cases less than 0.01 mg/l are common in systems using sulfide precipitation followed by clarification.

Some of the bench scale data, particularly in the case of lead, do not support such low effluent concentrations. However, lead is consistently removed to very low levels (less than 0.02 mg/l) in systems using hydroxide and carbonate precipitation and sedimentation.

Of particular interest is the ability of sulfide to precipitate hexavalent chromium (Cr+6) without prior reduction to the trivalent state as is required in the hydroxide process. When ferrous sulfide is used as the precipitant, iron and sulfide act as reducing agents for the hexavalent chromium according to the reaction:

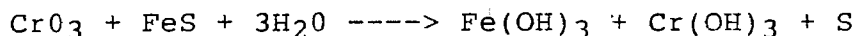

The sludge produced in this reaction consists mainly of ferric hydroxides, chromic hydroxides, and various metallic sulfides. Some excess hydroxyl ions are generated in this process, possibly requiring a downward re-adjustment of pH.

Based on the available data, Table VII-6 shows the minimum reliably attainable effluent concentrations for sulfide precipitation-sedimentation systems. These values are used to calculate performance predictions of sulfide precipitation-sedimentation systems.

Carbonate precipitation is sometimes used to precipitate metals, especially where precipitated metals values are to be recovered. The solubility of most metal carbonates is intermediate between hydroxide and sulfide solubilities; in addition, carbonates form easily filtered precipitates.

Carbonate ions appear to be particularly useful in precipitating lead and antimony. Sodium carbonate has been observed being added at treatment to improve lead precipitation and removal in some industrial plants. The lead hydroxide and lead carbonate solubility curves displayed in Figure VII-2 ("Heavy Metals Removal," by Kenneth Lanovette, Chemical Engineering/Deskbook Issue, October 17, 1977) explain this phenomenon.

Co-precipitation With Iron. The presence of substantial quantities of iron in metal bearing wastewaters before treatment has been shown to improve the removal of toxic metals. In some cases this iron is an integral part of the industrial wastewater; in other cases iron is deliberately added as a preliminary treatment or first step of treatment. The iron functions to improve toxic metal removal by three mechanisms: the iron co-precipitates with toxic metals forming a stable precipitate which desolubilizes the toxic metal; the iron improves the settleability of the precipitate; and the large amount of iron reduces the fraction of toxic metal in the precipitate. Co-precipitation with iron has been practiced for many years incidentally when iron was a substantial constituent of raw wastewater and intentionally when iron salts were added as a

coagulant aid. Aluminum or mixed iron-aluminum salt also have been used. The addition of iron for co-precipitation to aid in toxic metals removal is considered a routine part of state-of-the-art lime and settle technology which should be implemented as required to achieve optimal removal of toxic metals.

Co-precipitation using large amounts of ferrous iron salts is known as ferrite co-precipitation because magnetic iron oxide or ferrite is formed. The addition of ferrous salts (sulfate) is followed by alkali precipitation and air oxidation. The resultant precipitate is easily removed by filtration and may be removed magnetically. Data illustrating the performance of ferrite co-precipitation is shown in Table VII-7.

Advantages and Limitations. Chemical precipitation has proved to be an effective technique for removing many pollutants from industrial wastewater. It operates at ambient conditions and is well suited to automatic control. The use of chemical precipitation may be limited because of interference by chelating agents, because of possible chemical interference with mixed wastewaters and treatment chemicals, or because of the potentially hazardous situation involved with the storage and handling of those chemicals. Nonferrous metals forming wastewaters do not normally contain chelating agents or complex pollutant matrix formations which would interfere with or limit the use of chemical precipitation. Lime is usually added as a slurry when used in hydroxide precipitation. The slurry must be kept well mixed and the addition lines periodically checked to prevent blocking of the lines, which may result from a buildup of solids. Also, lime precipitation usually makes recovery of the precipitated metals difficult, because of the heterogeneous nature of most lime sludges.

The major advantage of the sulfide precipitation process is that the extremely low solubility of most metal sulfides promotes very high metal removal efficiencies; the sulfide process also has the ability to remove chromates and dichromates without preliminary reduction of the chromium to its trivalent state. In addition, sulfide can precipitate metals complexed with most complexing agents. The process demands care, however, in maintaining the pH of the solution at approximately 10 in order to restrict the generation of toxic hydrogen sulfide gas. For this reason, ventilation of the treatment tanks may be a necessary precaution in most installations. The use of insoluble sulfides reduces the problem of hydrogen sulfide evolution. As with hydroxide precipitation, excess sulfide ion must be present to drive the precipitation reaction to completion. Since the sulfide ion itself is toxic, sulfide addition must be carefully controlled to maximize heavy metals precipitation with a minimum of excess sulfide to avoid the necessity of post treatment. At very high excess sulfide levels and high pH, soluble mercury-sulfide compounds may also be formed. Where excess sulfide is present, aeration of the effluent stream can aid in oxidizing residual

sulfide to the less harmful sodium sulfate (Na_2SO_4). The cost of sulfide precipitants is high in comparison with hydroxide precipitants, and disposal of metallic sulfide sludges may pose problems. An essential element in effective sulfide precipitation is the removal of precipitated solids from the wastewater and proper disposal in an appropriate site. Sulfide precipitation will also generate a higher volume of sludge than hydroxide precipitation, resulting in higher disposal and dewatering costs. This is especially true when ferrous sulfide is used as the precipitant.

Sulfide precipitation may be used as a polishing treatment after hydroxide precipitation-sedimentation. This treatment configuration may provide the better treatment effectiveness of sulfide precipitation while minimizing the variability caused by changes in raw waste and reducing the amount of sulfide precipitant required. Sulfide is also effective as a pretreatment technology before lime and settle to remove specific pollutants such as chromium.

Operational Factors. Reliability: Alkaline chemical precipitation is highly reliable, although proper monitoring and control are required. Sulfide precipitation systems provide similar reliability.

Maintainability: The major maintenance needs involve periodic upkeep of monitoring equipment, automatic feeding equipment, mixing equipment, and other hardware. Removal of accumulated sludge is necessary for efficient operation of precipitation-sedimentation systems.

Solid Waste Aspects: Solids which precipitate out are removed in a subsequent treatment step. Ultimately, these solids require proper disposal.

Demonstration Status. Chemical precipitation of metal hydroxides is a classic waste treatment technology used by most industrial waste treatment systems. Chemical precipitation of some metals, in particular lead and antimony, in the carbonate form has been found to be feasible and is commercially used to permit metals recovery and water reuse. Full scale commercial sulfide precipitation units are in operation at numerous installations. As noted earlier, sedimentation to remove precipitates is discussed separately.

Use in Nonferrous Metals Forming Plants. Forty-six nonferrous metals forming plants currently operate chemical precipitation (lime or caustic systems). The quality of treatment provided, however, is variable. A review of collected data and on-site observations reveals that control of system parameters is often poor. Where precipitates are removed by clarification, retention times are likely to be short and cleaning and maintenance questionable. Similarly, pH control is frequently inadequate. As a result of these factors, effluent performance

at nonferrous metals forming plants nominally practicing the same wastewater treatment is observed to vary widely.

3. Cyanide Precipitation

Cyanide precipitation, although a method for treating cyanide in wastewaters, does not destroy cyanide. The cyanide is retained in the sludge that is formed. Reports indicate that during exposure to sunlight, the cyanide complexes can break down and form free cyanide. For this reason, the sludge from this treatment method must be disposed of carefully.

Cyanide may be precipitated and settled out of wastewaters by the addition of zinc sulfate or ferrous sulfate. In the presence of iron, cyanide will form extremely stable cyanide complexes. The addition of zinc sulfate or ferrous sulfate forms zinc ferrocyanide or ferro and ferricyanide complexes.

Adequate removal of the precipitated cyanide requires that the pH must be kept at 9.0 and an appropriate retention time be maintained. A study has shown that the formation of the complex is very dependent on pH. At a pH of either 8 or 10, the residual cyanide concentration measured is twice that of the same reaction carried out at a pH of 9. Removal efficiencies also depend heavily on the retention time allowed. The formation of the complexes takes place rather slowly. Depending upon the excess amount of zinc sulfate or ferrous sulfate added, at least a 30 minute retention time should be allowed for the formation of the cyanide complex before continuing on to the clarification stage.

One experiment with an initial concentration of 10 mg/l of cyanide showed that 98 percent of the cyanide was complexed ten minutes after the addition of ferrous sulfate at twice the theoretical amount necessary. Interference from other metal ions, such as cadmium, might result in the need for longer retention times.

Table VII-8 presents cyanide precipitation data from three coil coating plants. A fourth plant was visited for the purpose of observing plant testing of the cyanide precipitation system. Specific data from this facility are not included because: (1) the pH was usually well below the optimum level of 9.0; (2) the historical treatment data were not obtained using the standard cyanide analysis procedure; and (3) matched input-output data were not made available by the plant. Scanning the available data indicates that the raw waste CN level was in the range of 25.0; the pH 7.5; and treated CN level was from 0.1 to 0.2.

The concentrations shown on Table VII-8 are those of the stream entering and leaving the treatment system. Plant 1057 allowed a 27-minute retention time for the formation of the complex. The retention time for the other plants is not known. The data suggest that over a wide range of cyanide

concentration in the raw waste, the concentration of cyanide can be reduced in the effluent stream to or below 0.15 mg/l.

Application and Performance. Cyanide precipitation can be used when cyanide destruction is not feasible because of the presence of cyanide complexes which are difficult to destroy. Effluent concentrations of cyanide well below 0.15 mg/l are possible.

Advantages and Limitations. Cyanide precipitation is an inexpensive method of treating cyanide. Problems may occur when metal ions interfere with the formation of the complexes.

4. Granular Bed Filtration

Filtration occurs in nature as the surface and ground waters are cleansed by sand. Silica sand, anthracite coal, and garnet are common filter media used in water treatment plants. These are usually supported by gravel. The media may be used singly or in combination. The multimedia filters may be arranged to maintain relatively distinct layers by virtue of balancing the forces of gravity, flow, and buoyancy on the individual particles. This is accomplished by selecting appropriate filter flow rates (gpm/sq-ft), media grain size, and density.

Granular bed filters may be classified in terms of filtration rate, filter media, flow pattern, or method of pressurization. Traditional rate classifications are slow sand, rapid sand, and high rate mixed media. In the slow sand filter, flux or hydraulic loading is relatively low, and removal of collected solids to clean the filter is therefore relatively infrequent. The filter is often cleaned by scraping off the inlet face (top) of the sand bed. In the higher rate filters, cleaning is frequent and is accomplished by a periodic backwash, opposite to the direction of normal flow.

A filter may use a single medium such as sand or diatomaceous earth, but dual and mixed (multiple) media filters allow higher flow rates and efficiencies. Figure VII-32 shows five different filter configurations. The dual media filter usually consists of a fine bed of sand under a coarser bed of anthracite coal. The coarse coal removes most of the influent solids, while the fine sand performs a polishing function. At the end of the backwash, the fine sand settles to the bottom because it is denser than the coal, and the filter is ready for normal operation. The mixed media filter operates on the same principle, with the finer, denser media at the bottom and the coarser, less dense media at the top. The usual arrangement is garnet at the bottom (outlet end) of the bed, sand in the middle, and anthracite coal at the top. Some mixing of these layers occurs and is, in fact, desirable.

The flow pattern is usually top-to-bottom, but other patterns are sometimes used. Upflow filters are sometimes used, and in a horizontal filter the flow is horizontal. In a biflow filter,

the influent enters both the top and the bottom and exits laterally. The advantage of an upflow filter is that with an upflow backwash, the particles of a single filter medium are distributed and maintained in the desired coarse-to-fine (bottom-to-top) arrangement. The disadvantage is that the bed tends to become fluidized, which ruins filtration efficiency. The biflow design is an attempt to overcome this problem.

The classic granular bed filter operates by gravity flow; however, pressure filters are fairly widely used. They permit higher solids loadings before cleaning and are advantageous when the filter effluent must be pressurized for further downstream treatment. In addition, pressure filter systems are often less costly for low to moderate flow rates.

Figure VII-14 depicts a high rate, dual media, gravity downflow granular bed filter, with self-stored backwash. Both filtrate and backwash are piped around the bed in an arrangement that permits gravity upflow of the backwash, with the stored filtrate serving as backwash. Addition of the indicated coagulant and polyelectrolyte usually results in a substantial improvement in filter performance.

Auxilliary filter cleaning is sometimes employed in the upper few inches of filter beds. This is conventionally referred to as surface wash and is accomplished by water jets just below the surface of the expanded bed during the backwash cycle. These jets enhance the scouring action in the bed by increasing the agitation.

An important feature for successful filtration and backwashing is the underdrain. This is the support structure for the bed. The underdrain provides an area for collection of the filtered water without clogging from either the filtered solids or the media grains. In addition, the underdrain prevents loss of the media with the water, and during the backwash cycle it provides even flow distribution over the bed. Failure to dissipate the velocity head during the filter or backwash cycle will result in bed upset and the need for major repairs.

Several standard approaches are employed for filter underdrains. The simplest one consists of a parallel porous pipe imbedded under a layer of coarse gravel and attached via a manifold to a header pipe for effluent removal. Other approaches to the underdrain system are known as the Leopold and Wheeler filter bottoms. Both of these incorporate false concrete bottoms with specific porosity configurations to provide drainage and velocity head dissipation.

Filter system operation may be manual or automatic. The filter backwash cycle may be on a timed basis, a pressure drop basis with a terminal value which triggers backwash, or a solids carry-over basis from turbidity monitoring of the outlet stream. All of these schemes have been used successfully.

Application and Performance. Wastewater treatment plants often use granular bed filters for polishing after clarification, sedimentation, or other similar operations. Granular bed filtration thus has potential application to nearly all industrial plants. Chemical additives which enhance the upstream treatment equipment may or may not be compatible with or enhance the filtration process. Normal operating flow rates for various types of filters are:

Slow Sand	2.04 - 5.30 l/sq m-hr
Rapid Sand	40.74 - 51.48 l/sq m-hr
High Rate Mixed Media	81.48 - 122.22 l/sq m-hr

Suspended solids are commonly removed from wastewater streams by filtering through a deep 0.3-0.9 m (1-3 feet) granular filter bed. The porous bed formed by the granular media can be designed to remove practically all suspended particles. Even colloidal suspensions (roughly 1 to 100 microns) are adsorbed on the surface of the media grains as they pass in close proximity in the narrow bed passages.

Properly operated filters following some pretreatment to reduce suspended solids below 200 mg/l should produce water with less than 10 mg/l TSS. For example, multimedia filters produced the effluent qualities shown in Table VII-9.

Advantages and Limitations. The principal advantages of granular bed filtration are its comparatively (to other filters) low initial and operating costs, reduced land requirements over other methods to achieve the same level of solids removal, and elimination of chemical additions to the discharge stream. However, the filter may require pretreatment if the solids level is high (over 100 mg/l). Operator training must be somewhat extensive due to the controls and periodic backwashing involved, and backwash must be stored and dewatered for economical disposal.

Operational Factors. Reliability: The recent improvements in filter technology have significantly improved filtration reliability. Control systems, improved designs, and good operating procedures have made filtration a highly reliable method of water treatment.

Maintainability: Deep bed filters may be operated with either manual or automatic backwash. In either case, they must be periodically inspected for media attrition, partial plugging, and leakage. Where backwashing is not used, collected solids must be removed by shoveling, and filter media must be at least partially replaced.

Solid Waste Aspects: Filter backwash is generally recycled within the wastewater treatment system, so that the solids

ultimately appear in the clarifier sludge stream for subsequent dewatering. Alternatively, the backwash stream may be dewatered directly or, if there is no backwash, the collected solids may be disposed of in a suitable landfill. In either of these situations there is a solids disposal problem similar to that of clarifiers.

Demonstration Status. Deep bed filters are in common use in municipal treatment plants. Their use in polishing industrial clarifier effluent is increasing, and the technology is proven and conventional. As noted previously, however, little data is available characterizing the effectiveness of filters presently in use within the industry. One nonferrous metals forming plant has granular media filtration in place.

5. Pressure Filtration

Pressure filtration works by pumping the liquid through a filter material which is impenetrable to the solid phase. The positive pressure exerted by the feed pumps or other mechanical means provides the pressure differential which is the principal driving force. Figure VII-15) represents the operation of one type of pressure filter.

A typical pressure filtration unit consists of a number of plates or trays which are held rigidly in a frame to ensure alignment and which are pressed together between a fixed end and a traveling end. On the surface of each plate, a filter made of cloth or synthetic fiber is mounted. The feed stream is pumped into the unit and passes through holes in the trays along the length of the press until the cavities or chambers between the trays are completely filled. The solids are then entrapped, and a cake begins to form on the surface of the filter material. The water passes through the fibers, and the solids are retained.

At the bottom of the trays are drainage ports. The filtrate is collected and discharged to a common drain. As the filter medium becomes coated with sludge, the flow of filtrate through the filter drops sharply, indicating that the capacity of the filter has been exhausted. The unit must then be cleaned of the sludge. After the cleaning or replacement of the filter media, the unit is again ready for operation.

Application and Performance. Pressure filtration is used in nonferrous metals forming plants for sludge dewatering and also for direct removal of precipitated and other suspended solids from wastewater. Because dewatering is such a common operation in treatment systems, pressure filtration is a technique which can be found in many industries concerned with removing solids from their waste stream.

In a typical pressure filter, chemically preconditioned sludge detained in the unit for one to three hours under pressures varying from 5 to 13 atmospheres exhibited final solids content between 25 and 50 percent.

Advantages and Limitations. The pressures which may be applied to a sludge for removal of water by filter presses that are currently available range from 5 to 13 atmospheres. As a result, pressure filtration may reduce the amount of chemical pretreatment required for sludge dewatering. Sludge retained in the form of the filter cake has a higher percentage of solids than that from centrifuge or vacuum filter. Thus, it can be easily accommodated by materials handling systems.

As a primary solids removal technique, pressure filtration requires less space than clarification and is well suited to streams with high solids loadings. The sludge produced may be disposed without further dewatering, but the amount of sludge is increased by the use of filter precoat materials (usually diatomaceous earth). Also, cloth pressure filters often do not achieve as high a degree of effluent clarification as clarifiers or granular media filters.

Two disadvantages associated with pressure filtration in the past have been the short life of the filter cloths and lack of automation. New synthetic fibers have largely offset the first of these problems. Also, units with automatic feeding and pressing cycles are now available.

For larger operations, the relatively high space requirements, as compared to those of a centrifuge, could be prohibitive in some situations.

Operational Factors. Reliability: With proper pretreatment, design, and control, pressure filtration is a highly dependable system.

Maintainability: Maintenance consists of periodic cleaning or replacement of the filter media, drainage grids, drainage piping, filter pans, and other parts of the system. If the removal of the sludge cake is not automated, additional time is required for this operation.

Solid Waste Aspects: Because it is generally drier than other types of sludges, the filter sludge cake can be handled with relative ease. The accumulated sludge may be disposed by any of the accepted procedures depending on its chemical composition. The levels of toxic metals present in sludge from treating nonferrous metals forming wastewater necessitate proper disposal.

Demonstration Status. Pressure filtration is a commonly used technology in a great many commercial applications.

6. Settling

Settling is a process which removes solid particles from a liquid matrix by gravitational force. This is done by reducing the velocity of the feed stream in a large volume tank or lagoon so

that gravitational settling can occur. Figure VII-16 shows two typical settling devices.

Settling is often preceded by chemical precipitation which converts dissolved pollutants to solid form and by coagulation which enhances settling by coagulating suspended precipitates into larger, faster settling particles.

If no chemical pretreatment is used, the wastewater is fed into a tank or lagoon where it loses velocity and the suspended solids are allowed to settle out. Long retention times are generally required. Accumulated sludge can be collected either periodically or continuously and either manually or mechanically. Simple settling, however, may require excessively large catchments, and long retention times (days as compared with hours) to achieve high removal efficiencies. Because of this, addition of settling aids such as alum or polymeric flocculants is often economically attractive.

In practice, chemical precipitation often precedes settling, and inorganic coagulants or polyelectrolytic flocculants are usually added as well. Common coagulants include sodium sulfate, sodium aluminate, ferrous or ferric sulfate, and ferric chloride. Organic polyelectrolytes vary in structure, but all usually form larger floc particles than coagulants used alone.

Following this pretreatment, the wastewater can be fed into a holding tank or lagoon for settling, but is more often piped into a clarifier for the same purpose. A clarifier reduces space requirements, reduces retention time, and increases solids removal efficiency. Conventional clarifiers generally consist of a circular or rectangular tank with a mechanical sludge collecting device or with a sloping funnel-shaped bottom designed for sludge collection. In advanced settling devices, inclined plates, slanted tubes, or a lamellar network may be included within the clarifier tank in order to increase the effective settling area, increasing capacity. A fraction of the sludge stream is often recirculated to the inlet, promoting formation of a denser sludge.

Settling is based on the ability of gravity (Newton's Law) to cause small particles to fall or settle (Stokes' Law) through the fluid they are suspended in. Presuming that the factors affecting chemical precipitation are controlled to achieve a readily settleable precipitate, the principal factors controlling settling are the particle characteristics and the upflow rate of the suspending fluid. When the effective settling area is great enough to allow settling, any increase in the effective settling area will produce no increase in solids removal.

Therefore, if a plant has installed equipment that provides the appropriate overflow rate, the precipitated metals in the effluent can be effectively removed. The number of settling devices operated in series or in parallel by a facility is not important with regard to suspended solids removal; rather it

is important that the settling devices provide sufficient effective settling area.

Another important facet of sedimentation theory is that diminishing removal of suspended solids is achieved for a unit increase in the effective settling area. Generally, it has been found that suspended solids removal performance varies with the effective up-flow rate. Qualitatively the performance increases asymptotically to a maximum level beyond which a decrease in up-flow rate provides incrementally insignificant increases in removal. This maximum level is dictated by particle size distribution, density characteristic of the particles and the water matrix, chemicals used for precipitation and pH at which precipitation occurs.

Application and Performance. Settling or clarification is used in the nonferrous metals forming category to remove precipitated metals. Settling can be used to remove most suspended solids in a particular waste stream; thus it is used extensively by many different industrial waste treatment facilities. Because most metal ion pollutants are readily converted to solid metal hydroxide precipitates, settling is of particular use in those industries associated with metal production, metal finishing, metal working, and any other industry with high concentrations of metal ions in their wastewaters. In addition to toxic metals, suitably precipitated materials effectively removed by settling include aluminum, iron, manganese, cobalt, molybdenum, fluoride, phosphate, and many others.

A properly operating settling system can efficiently remove suspended solids, precipitated metal hydroxides, and other impurities from wastewater. The performance of the process depends on a variety of factors, including the density and particle size of the solids, the effective charge on the suspended particles, and the types of chemicals used in pretreatment. The site of flocculant or coagulant addition also may significantly influence the effectiveness of clarification. If the flocculant is subjected to too much mixing before entering the clarifier, the complexes may be sheared and the settling effectiveness diminished. At the same time, the flocculant must have sufficient mixing and reaction time in order for effective set-up and settling to occur. Plant personnel have observed that the line or trough leading into the clarifier is often the most efficient site for flocculant addition. The performance of simple settling is a function of the retention time, particle size and density, and the surface area of the basin.

The data displayed in Table VII-10 indicate suspended solids removal efficiencies in settling systems. The mean effluent TSS concentration obtained by the plants shown in Table VII-10 is 10.1 mg/l. Influent concentrations averaged 838 mg/l. The maximum effluent TSS value reported is 23 mg/l. These plants all use alkaline pH adjustment to precipitate metal hydroxides, and most add a coagulant or flocculant prior to settling.

Advantages and Limitations. The major advantage of simple settling is its simplicity as demonstrated by the gravitational settling of solid particulate waste in a holding tank or lagoon. The major problem with simple settling is the long retention time necessary to achieve complete settling, especially if the specific gravity of the suspended matter is close to that of water. Some materials cannot be practically removed by simple settling alone.

Settling performed in a clarifier is effective in removing slow-settling suspended matter in a shorter time and in less space than a simple settling system. Also, effluent quality is often better from a clarifier. The cost of installing and maintaining a clarifier, however, is substantially greater than the costs associated with simple settling.

Inclined plate, slant tube, and lamella settlers have even higher removal efficiencies than conventional clarifiers, and greater capacities per unit area are possible. Installed costs for these advanced clarification systems are claimed to be one half the cost of conventional systems of similar capacity.

Operational Factors. Reliability: Settling can be a highly reliable technology for removing suspended solids. Sufficient retention time and regular sludge removal are important factors affecting the reliability of all settling systems. Proper control of pH adjustment, chemical precipitation, and coagulant or flocculant addition are additional factors affecting settling efficiencies in systems (frequently clarifiers) where these methods are used.

Those advanced settlers using slanted tubes, inclined plates, or a lamellar network may require pre-screening of the waste in order to eliminate any fibrous materials which could potentially clog the system. Some installations are especially vulnerable to shock loadings, as from storm water runoff, but proper system design will prevent this.

Maintainability: When clarifiers or other advanced settling devices are used, the associated system utilized for chemical pretreatment and sludge dragout must be maintained on a regular basis. Routine maintenance of mechanical parts is also necessary. Lagoons require little maintenance other than periodic sludge removal.

Demonstration Status. Settling represents the typical method of solids removal and is employed extensively in industrial waste treatment. The advanced clarifiers are just beginning to appear in significant numbers in commercial applications. Seventy-five nonferrous metals forming plants currently operate sedimentation or clarification systems.

7. Skimming

Pollutants with a specific gravity less than water will often float unassisted to the surface of the wastewater. Skimming removes these floating wastes. Skimming normally takes place in a tank designed to allow the floating debris to rise and remain on the surface, while the liquid flows to an outlet located below the floating layer. Skimming devices are therefore suited to the removal of non-emulsified oils from raw waste streams. Common skimming mechanisms include the rotating drum type, which picks up oil from the surface of the water as it rotates. A doctor blade scrapes oil from the drum and collects it in a trough for disposal or reuse. The water portion is allowed to flow under the rotating drum. Occasionally, an underflow baffle is installed after the drum; this has the advantage of retaining any floating oil which escapes the drum skimmer. The belt type skimmer is pulled vertically through the water, collecting oil which is scraped off from the surface and collected in a drum. Gravity separators (see Figure VII-33), such as the API type, utilize overflow and underflow baffles to skim a floating oil layer from the surface of the wastewater. An overflow-underflow baffle allows a small amount of wastewater (the oil portion) to flow over into a trough for disposal or reuse while the majority of the water flows underneath the baffle. This is followed by an overflow baffle, which is set at a height relative to the first baffle such that only the oil bearing portion will flow over the first baffle during normal plant operation. A diffusion device, such as a vertical slot baffle, aids in creating a uniform flow through the system and in increasing oil removal efficiency.

Application and Performance. Oil skimming is used in nonferrous metals forming plants to remove free oil used as a forming lubricant. Another source of oil is lubricants for drive mechanisms and other machinery contacted by process water. Skimming is applicable to any waste stream containing pollutants which float to the surface. It is commonly used to remove free oil, grease, and soaps. Skimming is often used in conjunction with air flotation or clarification in order to increase its effectiveness.

The removal efficiency of a skimmer is partly a function of the retention time of the water in the tank. Larger, more buoyant particles require less retention time than smaller particles. Thus, the efficiency also depends on the composition of the waste stream. The retention time required to allow phase separation and subsequent skimming varies from 1 to 15 minutes, depending on the wastewater characteristics.

API or other gravity-type separators tend to be more suitable for use where the amount of surface oil flowing through the system is consistently significant. Drum and belt type skimmers are applicable to waste streams which evidence smaller amounts of floating oil and where surges of floating oil are not a problem. Using an API separator system in conjunction with a drum type

skimmer is a very effective method of removing floating contaminants from nonemulsified oily waste streams. Sampling data shown in Table VII-11 illustrate the capabilities of the technology with both extremely high and moderate oil influent levels.

These data are intended to be illustrative of the very high level of oil and grease removals attainable in a simple two-step oil removal system. Based on the performance of installations in a variety of manufacturing plants and permit requirements that are consistently achieved, it has been determined that effluent oil levels may be reliably reduced below 10 mg/l with moderate influent concentrations. Very high concentrations of oil such as the 22 percent shown above may require two-step treatment to achieve this level.

Skimming which removes oil may also be used to remove base levels of organics. Plant sampling data show that many organic compounds tend to be removed in standard wastewater treatment equipment. Oil separation not only removes oil but also organics that are more soluble in oil than in water. Clarification removes organic solids directly and probably removes dissolved organics by adsorption on inorganic solids.

The source of these organic pollutants is not always known with certainty, although in metal forming operations they seem to derive mainly from various process lubricants. They are also sometimes present in the plant water supply, as additives to proprietary formulations of cleaners, or as the result of leaching from plastic lines and other materials.

High molecular weight organics in particular are much more soluble in organic solvents than in water. Thus they are much more concentrated in the oil phase that is skimmed than in the wastewater. The ratio of solubilities of a compound in oil and water phases is called the partition coefficient. The logarithm of the partition coefficients for selected polynuclear aromatic hydrocarbon (PAH) and other toxic organic compounds in octanol and water are shown in Table VII-12.

A review of priority organic compounds commonly found in metal forming operation waste streams indicated that incidental removal of these compounds often occurs as a result of oil removal or clarification processes. When all organics analyses from visited plants are considered, removal of organic compounds by other waste treatment technologies appears to be marginal in many cases. However, when only raw waste concentrations of 0.05 mg/l or greater are considered, incidental organics removal becomes much more apparent. Lower values, those less than 0.05 mg/l, are much more subject to analytical variation, while higher values indicate a significant presence of a given compound. When these factors are taken into account, analysis data indicate that most clarification and oil removal treatment systems remove significant amounts of the toxic organic compounds present in the

raw waste. The API oil-water separation system performed notably in this regard, as shown in Table VII-13.

Data from five plant days demonstrate removal of organics by the combined oil skimming and settling operations performed on coil coating wastewaters. Days were chosen where treatment system influent and effluent analyses provided paired data points for oil and grease and the organics present. All organics found at quantifiable levels on those days were included. Further, only those days were chosen where oil and grease raw wastewater concentrations exceeded 10 mg/l and where there was reduction in oil and grease going through the treatment system. All plant sampling days which met the above criteria are included below. The conclusion is that when oil and grease are removed, organics also are removed.

Percent Removal

Plant-Day	Oil & Grease	Organics
1054-3	95.9	98.2
13029-2	98.3	78.0
13029-3	95.1	77.0
38053-1	96.8	81.3
38053-2	98.5	86.3
Mean	96.9	84.2

The unit operation most applicable to removal of trace priority organics is adsorption, and chemical oxidation is another possibility. Biological degradation is not generally applicable because the organics are not present in sufficient concentration to sustain a biomass and because most of the organics are resistant to biodegradation.

Advantages and Limitations. Skimming as a pretreatment is effective in removing naturally floating waste material. It also improves the performance of subsequent downstream treatments. Many pollutants, particularly dispersed or emulsified oil, will not float "naturally" but require additional treatments. Therefore, skimming alone may not remove all the pollutants capable of being removed by air flotation or other more sophisticated technologies.

Operational Factors. Reliability: Because of its simplicity, skimming is a very reliable technique.

Maintainability: The skimming mechanism requires periodic lubrication, adjustment, and replacement of worn parts.

Solid Waste Aspects: The collected layer of debris must be disposed of by contractor removal, landfill, or incineration. Because relatively large quantities of water are present in the

collected wastes, incineration is not always a viable disposal method.

Demonstration Status. Skimming is a common operation utilized extensively by industrial waste treatment systems. Oil skimming is used in 30 nonferrous metals forming plants.

8. Chemical Emulsion Breaking

Chemical treatment is often used to break stable oil-in-water (O-W) emulsions. An O-W emulsion consists of oil dispersed in water, stabilized by electrical charges and emulsifying agent. A stable emulsion will not separate or break down without some form of treatment.

Once an emulsion is broken, the difference in specific gravities allows the oil to float to the surface of the water. Solids usually form a layer between the oil and water, since some oil is retained in the solids. The longer the retention time, the more complete and distinct the separation between the oil, solids, and water will be. Often other methods of gravity differential separation, such as air flotation or rotational separation (e.g., centrifugation), are used to enhance and speed separation. A schematic flow diagram of one type of application is shown in Figure VII-31.

The major equipment required for chemical emulsion breaking includes: reaction chambers with agitators, chemical storage tanks, chemical feed systems, pumps, and piping.

Emulsifiers may be used in the plant to aid in stabilizing or forming emulsions. Emulsifiers are surface-active agents which alter the characteristics of the oil and water interface. These surfactants have rather long polar molecules. One end of the molecule is particularly soluble in water (e.g., carboxyl, sulfate, hydroxyl, or sulfonate groups) and the other end is readily soluble in oils (an organic group which varies greatly with the different surfactant type). Thus, the surfactant emulsifies or suspends the organic material (oil) in water. Emulsifiers also lower the surface tension of the O-W emulsion as a result of solvation and ionic complexing. These emulsions must be destabilized in the treatment system.

Application and Performance. Emulsion breaking is applicable to waste streams containing emulsified oils or lubricants such as rolling and drawing emulsions. Typical chemical emulsion breaking efficiencies are given in Table VII-30.

Treatment of spent O-W emulsions involves the use of chemicals to break the emulsion followed by gravity differential separation. Factors to be considered for breaking emulsions are type of chemicals, dosage and sequence of addition, pH, mechanical shear and agitation, heat, and retention time.

Alum, alum, ferric chloride, and organic emulsion breakers break emulsions by neutralizing repulsive charges between particles, precipitating or salting out emulsifying agents, or altering the interfacial film between the oil and water so it is readily broken. Reactive cations (e.g., H(+1), Al(+3), Fe(+3), and cationic polymers) are particularly effective in breaking dilute O-W emulsions. Once the charges have been neutralized or the interfacial film broken, the small oil droplets and suspended solids will be adsorbed on the surface of the floc that is formed, or break out and float to the top. Various types of emulsion-breaking chemicals are used for the various types of oils.

If more than one chemical is required, the sequence of addition can make quite a difference in both breaking efficiency and chemical dosages.

Wastewater pH plays an important role in emulsion breaking, especially if cationic inorganic chemicals, such as alum, are used as coagulants. A depressed pH in the range of 2 to 4 keeps the aluminum ion in its most positive state where it can function most effectively for charge neutralization. After some of the oil is broken free and skimmed, raising the pH into the 6 to 8 range with lime or caustic will cause the aluminum to hydrolyze and precipitate as aluminum hydroxide. This floc entraps or adsorbs destabilized oil droplets which can then be separated from the water phase. Cationic polymers can break emulsions over a wider pH range and thus avoid acid corrosion and the additional sludge generated from neutralization; however, an inorganic flocculant is usually required to supplement the polymer emulsion breaker's adsorptive properties.

Mixing is important in breaking O-W emulsions. Proper chemical feed and dispersion is required for effective results. Mixing also causes collisions which help break the emulsion, and subsequently helps to agglomerate droplets.

In all emulsions, the mix of two immiscible liquids has a specific gravity very close to that of water. Heating lowers the viscosity and increases the apparent specific gravity differential between oil and water. Heating also increases the frequency of droplet collisions, which helps to rupture the interfacial film.

Chemical emulsion breaking can be used with oil skimming to achieve the treatment effectiveness concentrations that oil skimming alone will achieve for non-emulsified streams. This type of treatment is proven to be reliable and is considered state-of-the-art for nonferrous metals forming emulsified oily wastewaters.

Advantages and Limitations. Advantages gained from the use of chemicals for breaking O-W emulsions are the high removal efficiency potential and the possibility of reclaiming the oily waste. Disadvantages are corrosion problems associated with

acid-alum systems. skilled operator requirements for operation, treatment, and chemical sludges produced.

Operational Factors. Reliability: Chemical emulsion breaking is a very reliable process. The main control parameters, pH and temperature, are fairly easy to control.

Maintainability: Maintenance is required on pumps, motors, and valves, as well as periodic cleaning of the treatment tank to remove any accumulated solids. Energy use is limited to mixers and pumps.

Solid Waste Aspects: The surface oil and oily sludge produced are usually hauled away by a licensed contractor. If the recovered oil has a sufficiently low percentage of water, it may be burned for its fuel value or processed and reused.

Demonstration Status. Twelve plants in the nonferrous metals forming category currently break emulsions with chemicals.

MAJOR TECHNOLOGY EFFECTIVENESS

The performance of individual treatment technologies was presented above. Performance of operating systems is discussed here. Two different systems are considered: L&S (hydroxide precipitation and sedimentation or lime and settle) and LS&F (hydroxide precipitation, sedimentation, and filtration or lime, settle, and filter). Subsequently, an analysis of effectiveness of such systems is made to develop one-day maximum, and ten-day and thirty-day average concentration levels to be used in regulating pollutants. Evaluation of the L&S and the LS&F systems is carried out on the assumption that chemical reduction of chromium, cyanide precipitation, and oil removal are installed and operating properly where appropriate.

L&S Performance -- Combined Metals Data Base

A data base known as the "combined metals data base" (CMDB) was used to determine treatment effectiveness of lime and settle treatment for certain pollutants. The CMDB was developed over several years and has been used in a number of regulations. During the development of coil coating and other categorical effluent limitations and standards, chemical analysis data were collected of raw wastewater (treatment influent) and treated wastewater (treatment effluent) from 55 plants (126 data days) sampled by EPA (or its contractor) using EPA sampling and chemical analysis protocols. These data are the initial data base for determining the effectiveness of L&S technology in treating nine pollutants. Each of the plants in the initial data base belongs to at least one of the following industry categories: aluminum forming, battery manufacturing, coil coating (including canmaking), copper forming, electroplating and porcelain enameling. All of the plants employ pH adjustment and hydroxide precipitation using lime or caustic, followed by Stokes' law settling (tank, lagoon or clarifier) for solids

removal. An analysis of this data was presented in the development documents for the proposed regulations for coil coating and porcelain enameling (January 1981). Prior to analyzing the data, some values were deleted from the data base. These deletions were made to ensure that the data reflect properly operated treatment systems. The following criteria were used in making these deletions:

- Plants where malfunctioning processes or treatment systems at the time of sampling were identified.
- Data days where pH was less than 7.0 for extended periods of time or TSS was greater than 50 mg/l (these are prima facie indications of poor operation).

In response to the coil coating and porcelain enameling proposals, some commenters claimed that it was inappropriate to use data from some categories for regulation of other categories. In response to these comments, the Agency reanalyzed the data. An analysis of variance was applied to the data for the 126 days of sampling to test the hypothesis of homogeneous plant mean raw and treated effluent levels across categories by pollutant. This analysis is described in the report "A Statistical Analysis of the Combined Metals Industries Effluent Data" which is in the administrative record supporting this rulemaking. Homogeneity is the absence of statistically discernable differences among the categories, while heterogeneity is the opposite, i.e., the presence of statistically discernable differences. The main conclusion drawn from the analysis of variance is that, with the exception of electroplating, the categories included in the data base are generally homogeneous with regard to mean pollutant concentrations in both raw and treated effluent. That is, when data from electroplating facilities are included in the analysis, the hypothesis of homogeneity across categories is rejected. When the electroplating data are removed from the analysis the conclusion changes substantially and the hypothesis of homogeneity across categories is not rejected. On the basis of this analysis, the electroplating data were removed from the data base used to determine limitations for the coil coating, and porcelain enameling, copper forming, aluminum forming, battery manufacturing, nonferrous metals manufacturing, canmaking, and nonferrous metals forming regulations.

The statistical analysis provides support for the technical engineering judgment that electroplating wastewaters are sufficiently different from the wastewaters of other industrial categories in the data base to warrant removal of electroplating data from the data base used to determine treatment effectiveness.

For the purpose of determining treatment effectiveness, additional data were deleted from the data base. These deletions were made, almost exclusively, in cases where effluent data points were associated with low influent values. This was done in two steps. First, effluent values measured on the same day as

influent values that were less than or equal to 0.1 mg/l were deleted. Second, the remaining data were screened for cases in which all influent values at a plant were low although slightly above the 0.1 mg/l value. These data were deleted not as individual data points but as plant clusters of data that were consistently low and thus not relevant to assessing treatment. A few data points were also deleted where malfunctions not previously identified were recognized. The data basic to the CMDB are displayed graphically in Figures VII-4 to 12.

After all deletions, 148 data points from 19 plants remained. These data were used to determine the concentration basis of limitations derived from the CMDB used for this regulation.

The CMDB was reviewed following its use in a number of proposed regulations. Comments pointed out a few errors in the data, and the Agency's review identified a few transcription errors and some data points that were appropriate for inclusion in the data that had not been used previously because of errors in data record identification numbers. Documents in the record of this rulemaking identify all the changes, the reasons for the changes, and the effect of these changes on the data base. Other comments on the CMDB asserted that the data base was too small and that the statistical methods used were overly complex. Responses to specific comments regarding the application of the CMDB to the nonferrous metals forming category are included in the record of this rulemaking. The Agency believes that the data base is adequate to determine effluent concentrations achievable with lime and settle treatment. The statistical methods employed in the analysis are well known and appropriate statistical references are provided in the documents in the record that describe the analysis.

The revised data base was reexamined for homogeneity. The earlier conclusions were unchanged. The categories show good overall homogeneity with respect to concentrations of the nine pollutants in both raw and treated wastewaters with the exception of electroplating.

Certain effluent data associated with low influent values were deleted, and then the remaining data were fit to a lognormal distribution to determine treatment effectiveness values. The deletion of data was done in two steps. First, effluent values measured on the same day as influent values that were less than or equal to 0.1 mg/l were deleted. Second, the remaining data were screened for cases in which all influent values at a plant were low although slightly above the 0.1 mg/l value. These data were deleted not as individual data points but as plant clusters of data that were consistently low and thus not relevant to assessing treatment. The revised combined metals data base used for this regulation consists of 162 data points from 18 plants.

One-day Effluent Values

The concentrations determined from the CMDB used to establish limitations and standards at proposal were also used to establish final limitations and standards. The basic assumption underlying the determination of treatment effectiveness is that the data for a particular pollutant are lognormally distributed by plant. The lognormal has been found to provide a satisfactory fit to plant effluent data in a number of effluent guidelines categories and there was no evidence that the lognormal was not suitable in the case of the CMDB. Thus, we assumed measurements of each pollutant from a particular plant, denoted by X , were assumed to follow a lognormal distribution with log mean " μ " and log variance σ^2 . The mean, variance and 99th percentile of X are then:

$$\text{mean of } X = E(X) = \exp(\mu + \sigma^2/2)$$

$$\text{variance of } X = V(X) = \exp(2\mu + \sigma^2) [\exp(\sigma^2) - 1]$$

$$99\text{th percentile} = X_{.99} = \exp(\mu + 2.33\sigma)$$

where \exp is e , the base of the natural logarithm. The term lognormal is used because the logarithm of X has a normal distribution with mean μ and variance σ^2 . Using the basic assumption of lognormality the actual treatment effectiveness was determined using a lognormal distribution that, in a sense, approximates the distribution of an average of the plants in the data base, i.e., an "average plant" distribution. The notion of an "average plant" distribution is not a strict statistical concept but is used here to determine limits that would represent the performance capability of an average of the plants in the data base.

This "average plant" distribution for a particular pollutant was developed as follows: the log mean was determined by taking the average of all the observations for the pollutant across plants. The log variance was determined by the pooled within-plant variance. This is the weighted average of the plant variances. Thus, the log mean represents the average of all the data for the pollutant and the log variance represents the average of the plant log variances or average plant variability for the pollutant.

The one day effluent values were determined as follows:

Let X_{ij} = the j th observation on a particular pollutant at plant i where

$$i = 1, \dots, I$$

$$j = 1, \dots, J_i$$

$$I = \text{total number of plants}$$

J_i = number of observations at plant i .

Then $y_{ij} = \ln X_{ij}$

where \ln means the natural logarithm.

Then $y = \log$ mean over all plants

$$= \sum_{i=1}^I \sum_{j=1}^{J_i} y_{ij}/n,$$

where n = total number of observations

$$= \sum_{i=1}^I J_i$$

and $V(y)$ = pooled log variance

$$= \frac{\sum_{i=1}^I (J_i - 1) S_i^2}{\sum_{i=1}^I (J_i - 1)}$$

where S_i^2 = log variance at plant i

$$= \sum_{j=1}^{J_i} (y_{ij} - \bar{y}_i)^2 / (J_i - 1)$$

\bar{y}_i = log mean at plant i .

Thus, y and $V(y)$ are the log mean and log variance, respectively, of the lognormal distribution used to determine the treatment effectiveness. The estimated mean and 99th percentile of this distribution form the basis for the long term average and daily maximum effluent limitations, respectively. The estimates are

$$\text{mean} = E(\hat{X}) = \exp(\bar{y}) \Psi_n(0.5V(y))$$

$$\text{99th percentile} = \hat{X}_{.99} = \exp[\bar{y} + 2.33 \sqrt{V(y)}]$$

where Ψ (.) is a Bessel function and \exp is e , the base of the natural logarithms (See Aitchison, J. and J.A.C. Brown, The Lognormal Distribution, Cambridge University Press, 1963). In cases where zeros were present in the data, a generalized form of

the lognormal, known as the delta distribution was used (See Aitchison and Brown, op. cit., Chapter 9).

For certain pollutants, this approach was modified slightly to ensure that well-operated lime and settle plants in all CMDB categories would achieve the pollutant concentration values calculated from the CMDB. For instance, after excluding the electroplating data and other data that did not reflect pollutant removal or proper treatment, the effluent copper data from the copper forming plants were statistically significantly greater than the copper data from the other plants. This indicated that copper forming plants might have difficulty achieving an effluent concentration value calculated from copper data from all CMDB categories. Thus, copper effluent values shown in Table VII-14 (page) are based only on the copper effluent data from the copper forming plants. That is, the log mean for copper is the mean of the logs of all copper values from the copper forming plants only and the log variance is the pooled log variance of the copper forming plant data only. A similar situation occurred in the case of lead. That is, after excluding the electroplating data, the effluent lead data from battery manufacturing were significantly greater than the other categories. This indicated that battery manufacturing plants might have difficulty achieving a lead concentration calculated from all the CMDB categories. The lead values proposed were therefore based on the battery manufacturing lead data only. Comments on the proposed battery manufacturing regulation objected to this procedure and asserted that the lead concentration values were too low. Following proposal, the Agency obtained additional lead effluent data from a battery manufacturing facility with well-operated lime and settle treatment. These data were combined with the proposal lead data and analyzed to determine the final treatment effectiveness concentrations. The mean lead concentration is unchanged at 0.12 mg/l but the final one-day maximum and monthly 10-day average maximum increased to 0.42 and 0.20 mg/l, respectively. A complete discussion of the lead data and analysis is contained in a memorandum in the record of this rulemaking.

In the case of cadmium, after excluding the electroplating data and data that did not reflect removal or proper treatment, there were insufficient data to estimate the log variance for cadmium. The variance used to determine the values shown in Table VII-14 for cadmium was estimated by pooling the within-plant variances for all the other metals. Thus, the cadmium variability is the average of the plant variability averaged over all the other metals. The log mean for cadmium is the mean of the logs of the cadmium observations only. A complete discussion of the data and calculations for all the metals is contained in the administrative record for this rulemaking.

Average Effluent Values

Average effluent values that form the basis for the monthly limitations were developed in a manner consistent with the method

used to develop one-day treatment effectiveness in that the lognormal distribution used for the one-day effluent values was also used as the basis for the average values. That is, we assume a number of consecutive measurements are drawn from the distribution of daily measurements. The average of ten measurements taken during a month was used as the basis for the monthly average limitations. The approach used for the 10 measurements values was employed previously in regulations for other categories and was proposed for the nonferrous metals forming category. That is, the distribution of the average of 10 samples from a lognormal was approximated by another lognormal distribution. Although the approximation is not precise theoretically, there is empirical evidence based on effluent data from a number of categories that the lognormal is an adequate approximation for the distribution of small samples. In the course of previous work the approximation was verified in a computer simulation study (see "Development Document for Existing Sources Pretreatment Standards for the Electroplating Point Source Category", EPA 440/1-79/003, U.S. Environmental Protection Agency, Washington, D.C., August 1979). We also note that the average values were developed assuming independence of the observations although no particular sampling scheme was assumed.

Ten-Sample Average

The formulas for the 10-sample limitations were derived on the basis of simple relationships between the mean and variance of the distributions of the daily pollutant measurements and the average of 10 measurements. We assume the daily concentration measurements for a particular pollutant, denoted by X , follow a lognormal distribution with log mean and log variance denoted by μ and σ^2 , respectively. Let X_{10} denote the mean of 10 consecutive measurements. The following relationships then hold assuming the daily measurements are independent:

$$\text{mean of } X_{10} = E(X_{10}) = E(X)$$

$$\text{variance of } X_{10} = V(X_{10}) = V(X) / 10.$$

Where $E(X)$ and $V(X)$ are the mean and variance of X , respectively, defined above. We then assume that X_{10} follows a lognormal distribution with log mean μ_{10} and log standard deviation σ_{10}^2 . The mean and variance of X_{10} are then

$$E(X_{10}) = \exp(\mu_{10} + 0.5\sigma_{10}^2)$$

$$V(X_{10}) = \exp(2\mu_{10} + \sigma_{10}^2) [\exp(\sigma_{10}^2) - 1]$$

Now, μ_{10} and σ_{10}^2 can be derived in terms of μ and σ^2 as

$$\mu_{10} = \mu + \sigma^2/2 - 0.5 \ln [1 + \exp(\sigma^2 - 1)/N]$$

$$\sigma_{10}^2 = \ln [1 + (\exp(\sigma^2) - 1/N)]$$

Therefore, μ_{10} and σ_{10}^2 can be estimated using the above relationships and the estimates of μ and σ^2 obtained for the underlying lognormal distribution. The 10-sample limitation value was determined by the estimate of the approximate 99th percentile of the distribution of the 10-sample average given by

$$X_{10} (.99) = \exp (\hat{\mu}_{10} + 2.33 \hat{\sigma}_{10}).$$

Where $\hat{\mu}_{10}$ and $\hat{\sigma}_{10}$ are the estimates of μ_{10} and σ_{10} , respectively.

Thirty-Sample Average

Monthly average values based on the average of 30 daily measurements were also calculated. These are included because monthly limitations based on 30 samples have been used in the past and for comparison with the 10-sample values. The average values based on 30 measurements are determined on the basis of a statistical result known as the Central Limit Theorem. This Theorem states that, under general and nonrestrictive assumptions, the distribution of a sum of a number of random variables, say n , is approximated by the normal distribution. The approximation improves as the number of variables, n , increases. The Theorem is quite general in that no particular distributional form is assumed for the distribution of the individual variables. In most applications (as in approximating the distribution of 30-day averages) the Theorem is used to approximate the distribution of the average of n observations of a random variable. The result makes it possible to compute approximate probability statements about the average in a wide range of cases. For instance, it is possible to compute a value below which a specified percentage (e.g., 99 percent) of the averages of n observations are likely to fall. Most textbooks state that 25 or 30 observations are sufficient for the approximation to be valid. In applying the Theorem to the distribution of the 30-day average effluent values, we approximate the distribution of the average of 30 observations drawn from the distribution of daily measurements and use the estimated 99th percentile of this distribution.

Thirty-Sample Average Calculation

The formulas for the 30-sample average were based on an application of the Central Limit Theorem. According to the Theorem, the average of 30 observations drawn from the distribution of daily measurements, denoted by X_{30} , is approximately normally distributed. The mean and variance of X_{30} are:

mean of $\bar{X}_{30} = E(\bar{X}_{30}) = E(X)$

variance of $\bar{X}_{30} = V(\bar{X}_{30}) = V(X)/30$.

The 30-sample average value was determined by the estimate of the approximate 99th percentile of the distribution of the 30-sample average given by

$$\bar{X}_{30}(\hat{.99}) = E(\hat{X}) = 2.33 \sqrt{V(X) / 30}$$

where

$$E(\hat{X}) = \exp(\bar{y}) \Psi_n(0.5\sqrt{V(y)})$$

$$\text{and } V(\hat{X}) = \exp(2\bar{y}) [\Psi_n(2\sqrt{V(y)}) - n(n-2/n-1) V(y)].$$

The formulas for $E(\hat{X})$ and $V(\hat{X})$ are estimates of $E(X)$ and $V(X)$, respectively, given in Aitchison, J. and J.A.C. Brown, The Lognormal Distribution, Cambridge University Press, 1963, page 45.

Application

In response to the proposed coil coating and porcelain enameling regulations, the Agency received comments pointing out that permits usually required less than 30 samples to be taken during a month while the monthly average used as the basis for permits and pretreatment requirements usually is based on the average of 30 samples.

In applying the treatment effectiveness values to regulations we have considered the comments, examined the sampling frequency required by many permits and considered the change in values of averages depending on the number of consecutive sampling days in the averages. The most common frequency of sampling required in permits is about ten samples per month or slightly greater than twice weekly. The 99th percentiles of the distribution of averages of ten consecutive sampling days are not substantially different from the 99th percentile of the distribution's 30-day average. (Compared to the one-day maximum, the ten-day average is about 80 percent of the difference between one- and 30-day values). Hence the ten-day average provides a reasonable basis for a monthly average limitation and is typical of the sampling frequency required by existing permits.

The monthly average limitation is to be achieved in all permits and pretreatment standards regardless of the number of samples required to be analyzed and averaged by the permit or the pretreatment authority.

Additional Pollutants

Twenty-three additional pollutant parameters were evaluated to determine the performance of lime and settle treatment systems

in removing them from industrial wastewater. Performance data for these parameters is not a part of the CMDB so other data available to the Agency from categories not included in the CMDB has been used to determine the long-term average performance of lime and settle technology for each pollutant. These data indicate that the concentrations shown in Table VII-15 are reliably attainable with hydroxide precipitation and settling. Treatment effectiveness values were calculated by multiplying the mean performance from Table VII-15 by the appropriate variability factor. (The variability factor is the ratio of the value of concern to the mean). The pooled variability factors are: one-day maximum - 4.100; ten-day average - 1.821; and 30-day average - 1.618 these one-, ten-, and thirty-day values are tabulated in Table VII-21.

In establishing which data were suitable for use in Table VII-14 two factors were heavily weighed: (1) the nature of the wastewater; and (2) the range of pollutants or pollutant matrix in the raw wastewater. These data have been selected from processes that generate dissolved metals in the wastewater and which are generally free from complexing agents. The pollutant matrix was evaluated by comparing the concentrations of pollutants found in the raw wastewaters with the range of pollutants in the raw wastewaters of the combined metals data set. These data are displayed in Tables VII-16 and VII-17 and indicate that there is sufficient similarity in the raw wastes to logically assume transferability of the treated pollutant concentrations to the combined metals data base. Nonferrous metals forming wastewaters also were compared to the wastewaters from plants in categories from which treatment effectiveness values were calculated. The available data on these added pollutants do not allow homogeneity analysis as was performed on the combined metals data base. The data source for each added pollutant is discussed separately.

Antimony (Sb) - The treatment effectiveness concentration for antimony is based on data from a battery and secondary lead plant. Both EPA sampling data and recent permit data (1978-1982) confirm the achievability of 0.7 mg/l in the battery manufacturing wastewater matrix included in the combined data set. The untreated wastewater matrix shown in Table VII-17 is comparable with the untreated wastewater from the combined metals data set.

Arsenic (As) - The treatment effectiveness concentration of 0.5 mg/l for arsenic is based on permit data from two nonferrous metals manufacturing plants. The untreated wastewater matrix shown in Table VII-17 is comparable with the combined data set matrix.

Beryllium (Be) - The treatment effectiveness of beryllium is transferred from the nonferrous metals manufacturing industry. The 0.3 mg/l performance is achieved at a beryllium plant with the comparable untreated wastewater matrix shown in Table VII-17.

Mercury (Hg) - The 0.06 mg/l treatment effectiveness concentration of mercury is based on data from four battery plants. The untreated wastewater matrix at these plants was considered in the combined metals data set.

Selenium (Se) - The 0.30 mg/l treatment effectiveness concentration of selenium is based on recent permit data from one of the nonferrous metals manufacturing plants also used for arsenic performance. The untreated wastewater matrix for this plant is shown in Table VII-17.

Silver (Ag) - The treatment effectiveness concentration of 0.1 mg/l for silver is based on an estimate from the inorganic chemicals industry. Additional data supporting a treatability as stringent or more stringent than 0.1 mg/l is also available from seven nonferrous metals manufacturing plants. The untreated wastewater matrix for these plants is comparable and summarized in Table VII-17.

Thallium (Tl) - The 0.50 mg/l treatment effectiveness concentration for thallium is transferred from the inorganic chemicals industry. Although no untreated wastewater data are available to verify comparability with the combined metals data set plants, no other sources of data for thallium treatability could be identified.

Aluminum (Al) - The 2.24 mg/l treatment effectiveness concentration of aluminum is based on the mean performance of three aluminum forming plants and one coil coating plant. These plants are from categories included in the combined metals data set, assuring untreated wastewater matrix comparability.

Barium (Ba) - The treatment effectiveness concentration for barium (0.42 mg/l) is based on data from one nonferrous metals forming plant. The untreated wastewater matrix shown in Table VII-17 is comparable with the combined metals data base.

Boron (B) - The treatment effectiveness concentration of 0.36 mg/l for boron is based on data from a nonferrous metals plant. The untreated wastewater matrix shown in Table VII-17 is comparable with the combined metals data base.

Cesium (Cs) - The treatment effectiveness concentration for cesium (0.124 mg/l) is based on the performance achievable for sodium using ion exchange technology. This transfer of performance is technically justifiable because of the similarity of the chemical and physical behavior of these monovalent atoms.

Cobalt (Co) - The 0.05 mg/l treatment effectiveness concentration is based on nearly complete removal of cobalt at a porcelain enameling plant with a mean untreated wastewater cobalt concentration of 4.31 mg/l. In this case, the analytical detection using aspiration techniques for this pollutant is used as the basis of the treatability. Porcelain enameling was

considered in the combined metals data base, assuring untreated wastewater matrix comparability.

Columbium (Cb) - Data collected at two refractory metals forming plants indicate that lime and settle reduces columbium to below the level of detection (using x-ray fluorescence analytical methods) when an operating pH of eight is maintained. Another sampled lime and settle treatment system is operated at a higher pH, from 10.5 to 11.5, effluent concentrations of columbium from this system are significantly higher. Therefore, the data indicate that if the treatment system is operated at a pH near 8, columbium should be removed to below the level of detection. The level of detection (0.12 mg/l) is used as the one-day maximum concentration for lime and settle treatment effectiveness. No long-term, 10-day, and 30-day average treatment effectiveness values are established since it is impossible to determine precisely what concentrations are achievable. The untreated wastewater matrix shown in Table VII-17 is comparable with the combined metals data base.

Fluoride (F) - The 14.5 mg/l treatment effectiveness concentration of fluoride is based on the mean performance (216 samples) of an electronics manufacturing plant. The untreated wastewater matrix for this plant shown in Table VII-17 is comparable to the combined metals data set. The fluoride level in the electronics wastewater (760 mg/l) is significantly greater than the fluoride level in raw nonferrous metals forming wastewater leading to the conclusion that the nonferrous metals forming wastewater should be no more difficult to treat for fluoride removal than the electronics wastewater. The fluoride level in the CMDB - electroplating data ranges from 1.29 to 70.0 mg/l. Fluoride concentrations in some waste streams, such as hydrofluoric acid surface treatment baths, the combined raw waste concentrations that mix concentrated fluoride wastewaters with dilute wastewaters range from 5.3 to 117 mg/l. leading to the conclusion that the nonferrous metals forming wastewater should be no more difficult to treat to remove fluoride than electronics wastewater.

Gallium (Ga) - The treatment effectiveness concentration of gallium is assumed to be the same as the level for chromium (0.084 mg/l) for the reasons discussed below for indium. The Agency requested data on the treatability of gallium and solicited comment on the assumption that the achievable performance for gallium should be similar received disputing this claim.

Germanium (Ge) - The treatment effectiveness concentration of germanium is assumed to be the same as the level for chromium (0.084 mg/l) for the reasons discussed for indium (see below). The Agency requested data on the treatability of germanium and solicited comment on the assumption that the achievable performance for germanium should be similar to that of chromium. No comments were received disputing this claim.

Gold (Au) - The treatment effectiveness concentration for gold is based on the performance achieved for paladium using ion exchange. This transfer of performance is technically justifiable because of the similarity of the physical and chemical behavior of these precious metals.

Hafnium (Hf) - The treatment effectiveness concentration for hafnium 7.28 mg/l is based on the transfer of performance data for zirconium. The Agency believes that since the water chemistry for zirconium and hafnium is similiar, hafnium can be removed to the same levels as zirconium.

Indium (In) - The treatment effectiveness concentration for indium is assumed to be the same as the level for chromium (0.084 mg/l). Lacking any treated effluent data for indium, a comparison was made between the theoretical solubilities of indium and the metals in the combined Metals Data Base: cadmium, chromium, copper, lead, nickel, and zinc. The theoretical solubility of indium (2.5×10^{-7}) is more similar to the theoretical solubility of chromium (1.64×10^{-8} mg/l) than it is to the theoretical solubilities of cadmium, copper, lead, nickel or zinc. The theoretical solubilities of these metals range from 20×10^{-3} to 2.2×10^{-5} mg/l. This comparison is further supported by the fact that indium and chromium both form hydroxides in the trivalent state. Cadmium, copper, lead, nickel and zinc all form divalent hydroxides.

Magnesium (Mg) - Data collected at a magnesium forming plant indicate that lime and settle reduces magnesium to below the level of detection. The level of detection (0.1 mg/l) is used as the one-day maximum concentration for lime and settle treatment effectiveness. No long-term, 10-day, and 30-day average treatment effectiveness values are established since it is impossible to determine precisely what concentrations are achievable.

Molybdenum (Mo) - The 1.83 mg/l treatment effectiveness concentration is based on data from a nonferrous metals manufacturing and forming, plant which uses coprecipitation of molybdenum with iron. The treatment effectiveness concentration of 1.83 mg/l is achievable with iron coprecipitation and lime and settle treatment. The untreated wastewater matrix show in Table VII-17 is comparable with the combined metals data base.

Phosphorus (P) - The 4.08 mg/l treatment effectiveness concentration of phosphorus is based on the mean of 44 samples including 19 samples from the Combined Metals Data Base and 25 samples from the electroplating data base. Inclusion of electroplating data with the combined metals data was considered appropriate, since the removal mechanism for phosphorus is a precipitation reaction with calcium rather than hydroxide.

Platinum (Pt) - The treatment effectiveness concentration for platinum is based on the performance achieved for pathadium using

ion exchange. This transfer of performance is technically justifiable because of the similarity of the physical and chemical behavior of these precious metals.

Radium 226 (Ra 226) - The treatment effectiveness concentration of 6.17 picocuries per liter for radium 226 is based on data from one facility in the uranium subcategory of the Ore Mining and Dressing category which practices barium chloride coprecipitation in conjunction with lime and settle treatment. The untreated wastewater matrix shown in Table VII-17 is comparable with the combined metals data base.

Rhenium (Re) - The treatment effectiveness concentration for rhenium (1.83 mg/l) is based on the performance achieved for molybdenum at a nonferrous metals manufacturing and forming plant. This transfer of performance is technically justifiable because of the similarity of the physical and chemical behavior of these compounds.

Rubidium (Rb) - The treatment effectiveness concentration for rubidium (0.124 mg/l) is based on the performance achievable for sodium using ion exchange technology. This transfer of performance is technically justifiable because of the similarity of the chemical and physical behavior of these monvalent atoms.

Tantalum (Ta) - As with columbium, data collected at two refractory metals forming plants indicate that lime and settle reduces tantalum to below the level of detection (using x-ray fluorescence analytical methods) when an operating pH of eight is maintained. Another sampled lime and settle treatment system is operated at a higher pH, from 10.5 to 11.5. Effluent concentrations of tantalum from this system are significantly higher. Therefore, the data indicate that if the treatment system is operated at a pH near 8, tantalum should be removed to below the level of detection. The level of detection (0.45 mg/l) is used as the one-day maximum concentration for lime and settle treatment effectiveness. No long-term, 10-day, and 30-day average treatment effectiveness values are established since it is impossible to determine precisely what concentrations are achievable. The untreated wastewater matrix shown in Table VII-17 is comparable with the combined metals data base.

Tin (Sn) - The treatment effectiveness concentration of 1.07 mg/l for tin is based on data from one metal finishing tin plant. The untreated wastewater matrix shown in Table VII-17 is comparable with the combined metals data base.

Titanium (Ti) - The 0.19 mg/l treatment effectiveness concentration is based on the mean performance of four nonferrous metals forming plants. A total of 9 samples were included in the calculation of the mean performance. The untreated wastewater matrix shown in Table VII-17 is comparable with the combined metals data base.

Tungsten (W) - The 1.29 mg/l treatment effectiveness concentration (using x-ray fluorescence analytical methods) is based on data collected from the refractory metals forming plant where an operation pH of 10.5 to 11.5 was used. The data indicate that maintaining the pH within this range achieves significantly better removal of tungsten than a pH near 8. Therefore, refractory metals forming plants that treat wastewaters containing both columbium, tantalum and tungsten or other metals that precipitate at a higher pH may need to use a two-stage lime and settle to remove all of these metals. The untreated wastewater matrix shown in Table VII-17 is comparable with the combined metals data base.

Uranium (U) - The 4.00 mg/l treatment effectiveness concentration (using fluorometry analytical methods) is based on the performance of one uranium forming plant. The untreated wastewater matrix shown in Table VII-17 is comparable with the combined metals data base.

Vanadium (V) - Data collected at two nonferrous metals forming plants indicate that lime and settle reduces vanadium to below the detection limit. The level of detection (0.10 mg/l) is used as the one-day maximum concentration for lime and settle treatment effectiveness. No long-term, 10-day, or 30-day average treatment effectiveness values are established since it is impossible to determine precisely what concentrations are achievable. The untreated wastewater matrix shown in Table VII-17 is comparable with the combined metals data base.

Zirconium (Zr) - The zirconium treatment effectiveness of 7.28 mg/l is based on the mean performance of two nonferrous metals forming plants with lime and settle treatment. One plant forms zirconium and the other plant forms refractory metals. The untreated wastewater matrix shown in Table VII-17 is comparable with the combined metals data base.

LS&F Performance

Tables VII-18 and VII-19 show long term data from two plants which have well operated precipitation-settling treatment followed by filtration. The wastewaters from both plants contain pollutants from metals processing and finishing operations (multi-category). Both plants reduce hexavalent chromium before neutralizing and precipitating metals with lime. A clarifier is used to remove much of the solids load and a filter is used to "polish" or complete removal of suspended solids. Plant A uses a pressure filter, while Plant B uses a rapid sand filter.

Raw wastewater data was collected only occasionally at each facility and the raw wastewater data is presented as an indication of the nature of the wastewater treated. Data from plant A was received as a statistical summary and is presented as received. Raw laboratory data was collected at Plant B and reviewed for spurious points and discrepancies. The method of

treating the data base is discussed below under lime, settle, and filter treatment effectiveness.

Table VII-20 shows long-term data for zinc and cadmium removal at Plant C, a primary zinc smelter, which operates a LS&F system. This data represents about 4 months (103 data days) taken immediately before the smelter was closed. It has been arranged similarly to the data from Plants A and B for comparison and use.

These data are presented to demonstrate the performance of precipitation-settling-filtration (LS&F) technology under actual operating conditions and over a long period of time.

It should be noted that the iron content of the raw wastewater of Plants A and B is high while that for Plant C is low. This results, for Plants A and B, in co-precipitation of toxic metals with iron. Precipitation using high-calcium lime for pH control yields the results shown above. Plant operating personnel indicate that this chemical treatment combination (sometimes with polymer assisted coagulation) generally produces better and more consistent metals removal than other combinations of sacrificial metal ions and alkalis.

The LS&F performance data presented here are based on systems that provide polishing filtration after effective L&S treatment. We have previously shown that L&S treatment is equally applicable to wastewaters from the five CMDB categories because of the homogeneity of its raw and treated wastewaters, and other factors. Because of the similarity of the wastewaters after L&S treatment, the Agency believes these wastewaters are equally amenable to treatment using polishing filters added to the L&S treatment system. The Agency concludes that LS&F data based on porcelain enameling and nonferrous metals manufacturing is directly applicable to the aluminum forming, copper forming, battery manufacturing, coil coating, nonferrous metals forming and metal molding and casting categories, and the canmaking subcategory as well as it is to porcelain enameling and nonferrous metals manufacturing smelting and refining.

Analysis of Treatment System Effectiveness

Data are presented in Table VII-14 showing the mean, one-day, 10-day and 30-day values for nine pollutants examined in the L&S combined metals data base. The pooled variability factor for seven metal pollutants (excluding cadmium because of the small number of data points) was determined and is used to estimate one-day, 10-day and 30-day values. (The variability factor is the ratio of the value of concern to the mean: the pooled variability factors are: one-day maximum - 4.100; ten-day average - 1.821; and 30-day average - 1.618.) For values not calculated from the CMDB as previously discussed, the mean value for pollutants shown in Table VII-15 were multiplied by the

variability factors to derive the value to obtain the one-, ten- and 30-day values. These are tabulated in Table VII-21.

The treatment effectiveness for sulfide precipitation and filtration has been calculated similarly. Long term average values shown in Table VII-6 have been multiplied by the appropriate variability factor to estimate one-day maximum, and ten-day and 30-day average values. Variability factors developed in the combined metals data base were used because the raw wastewaters are identical and the treatment methods are similar as both use chemical precipitation and solids removal to control metals.

LS&F technology data are presented in Tables VII-18 and VII-19. These data represent two operating plants (A and B) in which the technology has been installed and operated for some years. Plant A data was received as a statistical summary and is presented without change. Plant B data was received as raw laboratory analysis data. Discussions with plant personnel indicated that operating experiments and changes in materials and reagents and occasional operating errors had occurred during the data collection period. No specific information was available on those variables. To sort out high values probably caused by methodological factors from random statistical variability, or data noise, the Plant B data were analyzed. For each of four pollutants (chromium, nickel, zinc, and iron), the mean and standard deviation (σ) were calculated for the entire data set. A data day was removed from the complete data set when any individual pollutant concentration for that day exceeded the sum of the mean plus three sigma for that pollutant. Fifty-one data days (from a total of about 1300) were eliminated by this method.

Another approach was also used as a check on the above method of eliminating certain high values. The minimum values of raw wastewater concentrations from Plant B for the same four pollutants were compared to the total set of values for the corresponding pollutants. Any day on which the treated wastewater pollutant concentration exceeded the minimum value selected from raw wastewater concentrations for that pollutant was discarded. Forty-five days of data were eliminated by that procedure. Forty-three days of data in common were eliminated by either procedure. Since common engineering practice (mean plus 3 sigma) and logic (treated wastewater concentrations should be less than raw wastewater concentrations) seem to coincide, the data base with the 51 spurious data days eliminated is the basis for all further analysis. Range, mean plus standard deviation and mean plus two standard deviations are shown in Tables VII-18 and VII-19 for Cr, Cu, Ni, Zn and Fe.

The Plant B data were separated into 1979, 1978, and total data base (six years) segments. With the statistical analysis from Plant A for 1978 and 1979, this in effect created five data sets in which there is some overlap between the individual years and total data sets from Plant B. By comparing these five parts, it is apparent that they are quite similar and all appear

to be from the same family of numbers. The largest mean found among the five data sets for each pollutant was selected as the long-term mean for LS&F technology and is used as the LS&F mean in Table VII-21.

Plant C data was used as a basis for cadmium removal performance and as a check on the zinc values derived from Plants A and B. The cadmium data is displayed in Table VII-20 and is incorporated into Table VII-21 for LS&F. The zinc data was analyzed for compliance with the 1-day and 30-day values in Table VII-21; no zinc value of the 103 data points exceeded the 1-day zinc value of 1.02 mg/l. The 103 data points were separated into blocks of 30 points and averaged. Each of the 3 full 30-day averages was less than the Table VII-21 value of 0.31 mg/l. Additionally the Plant C raw wastewater pollutant concentrations (Table VII-20) are well within the range of raw wastewater concentrations of the combined metals data base (Table VII-16), further supporting the conclusion that Plant C wastewater data is comparable to similar data from Plants A and B.

Concentration values for regulatory use are displayed in Table VII-21. Mean one-day, ten-day and 30-day values for L&S for nine pollutants were taken from Table VII-14; the remaining L&S values were developed using the mean values in Table VII-15 and the mean variability factors discussed above.

LS&F mean values for Cd, Cr, Ni, Zn, and Fe are derived from Plants A, B, and C as discussed above. One-, ten- and thirty-day values are derived by applying the variability factor developed from the pooled data base for the specific pollutant to the mean for that pollutant. Other LS&F values are calculated using the long term average or mean and the appropriate variability factors.

Mean values for LS&F for pollutants not already discussed are derived by reducing the L&S mean by one-third. The one-third reduction was established after examining the percent reduction in concentrations going from L&S to LS&F data for Cd, Cr, Ni, Zn, and Fe. The average reduction is 0.3338 or one-third. Variability factors for these additional pollutants are identical to the variabilities established for L&S treatment of these pollutants (using the variance from the pooled metals data base or the mean of other pollutant variances if a pollutant-specific variance is not available). Since filtration is a non-preferential technology with regard to metals treated, and furthermore, is being used to polish relatively clean wastewater (wastewater after lime and settle treatment), EPA believes it is reasonable to assume that these additional pollutants will be removed at the same average rate.

Copper levels achieved at Plants A and B may be lower than generally achievable because of the high iron content and low copper content of the raw wastewaters. Therefore, the mean concentration value from Plants A and B achieved is not used; the LS&F mean for copper is derived from the L&S technology.

Uranium levels achieved by L&S treatment showed substantially less variability than the nine parameters included in the CMDB. The standard approach to the derivation of LS&F treatment effectiveness concentrations results in one-day, 10-day and 30-day values for LS&F treatment that are greater than the corresponding values for L&S treatment. Therefore, the LS&F values for uranium are derived by reducing the L&S long term, one-day, 10-day and 30-day values by one-third to derive the corresponding LS&F values.

L&S cyanide mean levels shown in Table VII-8 are ratioed to one-day, ten-day and 30-day values using mean variability factors. LS&F mean cyanide is calculated by applying the ratios of L&S and LS&F removals as discussed previously for LS&F metals limitations. The cyanide performance was arrived at by using the average metal variability factors. The treatment method used here is cyanide precipitation. Because cyanide precipitation is limited by the same physical processes as the metal precipitation, it is expected that the variabilities will be similar. Therefore, the average of the metal variability factors has been used as a basis for calculating the cyanide one-day, ten-day and thirty-day average treatment effectiveness values.

The filter performance for removing TSS as shown in Table VII-9 yields a mean effluent concentration of 2.61 mg/l and calculates to a 10-day average of 4.33, 30-day average of 3.36 mg/l and a one-day maximum of 8.88. These calculated values more than amply support the classic thirty-day and one-day values of 10 mg/l and 15 mg/l, respectively, which are used for LS&F.

Although iron concentrations were reduced with the application of a filter to the lime and settle system, some facilities using that treatment introduce iron compounds to aid settling. Therefore, the one-day, ten-day and 30-day values for iron at LS&F were held at the L&S level so as to not unduly penalize the operations which use the relatively less objectionable iron compounds to enhance removals of toxic metals.

The removal of additional fluoride by adding polishing filtration is suspect because lime and settle treatment removes calcium fluoride to a level near its solubility. The one available data point appears to question the ability of filters to achieve high removals of additional fluoride. The fluoride levels demonstrated for L&S are used as the treatment effectiveness for LS&F.

MINOR TECHNOLOGIES

Several other treatment technologies were considered for possible application in this category. These technologies are presented here.

9. Carbon Adsorption

The use of activated carbon to remove dissolved organics from water and wastewater is a long demonstrated technology. It is one of the most efficient organic removal processes available. This sorption process is reversible, allowing activated carbon to be regenerated for reuse by the application of heat and steam or solvent. Activated carbon has also proved to be an effective adsorbent for many toxic metals, including mercury. Regeneration of carbon which has adsorbed significant amounts of metals, however, may be difficult.

The term activated carbon applies to any amorphous form of carbon that has been specially treated to give high adsorption capacities. Typical raw materials include coal, wood, coconut shells, petroleum base residues, and char from sewage sludge pyrolysis. A carefully controlled process of dehydration, carbonization, and oxidation yields a product which is called activated carbon. This material has a high capacity for adsorption due primarily to the large surface area available for adsorption, 500 to 1500 m²/sq m resulting from a large number of internal pores. Pore sizes generally range from 10 to 100 angstroms in radius.

Activated carbon removes contaminants from water by the process of adsorption, or the attraction and accumulation of one substance on the surface of another. Activated carbon preferentially adsorbs organic compounds and, because of this selectivity, is particularly effective in removing organic compounds from aqueous solution.

Carbon adsorption requires pretreatment to remove excess suspended solids, oils, and greases. Suspended solids in the influent should be less than 50 mg/l to minimize backwash requirements; a downflow carbon bed can handle much higher levels (up to 2000 mg/l) but requires frequent backwashing. Backwashing more than two or three times a day is not desirable; at 50 mg/l suspended solids, one backwash will suffice. Oil and grease should be less than about 10 mg/l. A high level of dissolved inorganic material in the influent may cause problems with thermal carbon reactivation (i.e., scaling and loss of activity) unless appropriate preventive steps are taken. Such steps might include pH control, softening, or the use of an acid wash on the carbon prior to reactivation.

Activated carbon is available in both powdered and granular form. An adsorption column packed with granular activated carbon is shown in Figure VII-17. A flow diagram of an activated carbon adsorption system, with regeneration, is shown in Figure VII-35. Powdered carbon is less expensive per unit weight and may have slightly higher adsorption capacity, but it is more difficult to handle and to regenerate.

Application and Performance. Carbon adsorption is used to remove mercury from wastewaters. The removal rate is influenced by the

mercury level in the influent to the adsorption unit. In Table VII-25 removal levels found at three manufacturing facilities are listed.

In the aggregate these data indicate that very low effluent levels could be attained from any raw waste by use of multiple adsorption stages. This is characteristic of adsorption processes.

Isotherm tests have indicated that activated carbon is very effective in adsorbing 65 percent of the organic priority pollutants and is reasonably effective for another 22 percent. Specifically, for the organics of particular interest, activated carbon was very effective in removing 2,4-dimethylphenol, fluoranthene, isophorone, naphthalene, all phthalates, and phenanthrene. It was reasonably effective on 1,1,1-trichloroethane, 1,1-dichloroethane, phenol, and toluene. Table VII-23 summarizes the treatment effectiveness for most of the organic priority pollutants by activated carbon as compiled by EPA. Table VII-24 summarizes classes of organic compounds together with examples of organics that are readily adsorbed on carbon.

Advantages and Limitations. The major benefits of carbon treatment include applicability to a wide variety of organics and high removal efficiency. Inorganics such as cyanide, chromium, and mercury are also removed effectively. Variations in concentration and flow rate are well tolerated. The system is compact, and recovery of adsorbed materials is sometimes practical. However, destruction of adsorbed compounds often occurs during thermal regeneration. If carbon cannot be thermally desorbed, it must be disposed of along with any adsorbed pollutants. The capital and operating costs of thermal regeneration are relatively high. Cost surveys show that thermal regeneration is generally economical when carbon use exceeds about 1,000 lb/day. Carbon cannot remove low molecular weight or highly soluble organics. It also has a low tolerance for suspended solids, which must be removed to at least 50 mg/l in the influent water.

Operational Factors. Reliability: This system should be very reliable with upstream protection and proper operation and maintenance procedures.

Maintainability: This system requires periodic regeneration or replacement of spent carbon and is dependent upon raw waste load and process efficiency.

Solid Waste Aspects: Solid waste from this process is contaminated activated carbon that requires disposal. Carbon which undergoes regeneration reduces the solid waste problem by reducing the frequency of carbon replacement.

Demonstration Status. Carbon adsorption systems have been demonstrated to be practical and economical in reducing COD, BOD,

and related parameters in secondary municipal and industrial wastewaters; in removing toxic or refractory organics from isolated industrial wastewaters; in removing and recovering certain organics from wastewaters; and in removing and some times recovering selected inorganic chemicals from aqueous wastes. Carbon adsorption is a viable and economic process for organic waste streams containing up to 1 to 5 percent of refractory or toxic organics. Its applicability for removal of inorganics such as metals has also been demonstrated.

10. Centrifugation

Centrifugation is the application of centrifugal force to separate solids and liquids in a liquid-solid mixture or to effect concentration of the solids. The application of centrifugal force is effective because of the density differential normally found between the insoluble solids and the liquid in which they are contained. As a waste treatment procedure, centrifugation is applied to dewatering of sludges. One type of centrifuge is shown in Figure VII-18.

There are three common types of centrifuges; disc, basket, and conveyor. All three operate by removing solids under the influence of centrifugal force. The fundamental difference among the three types is the method by which solids are collected in and discharged from the bowl.

In the disc centrifuge, the sludge feed is distributed between narrow channels that are present as spaces between stacked conical discs. Suspended particles are collected and discharged continuously through small orifices in the bowl wall. The clarified effluent is discharged through an overflow weir.

A second type of centrifuge which is useful in dewatering sludges is the basket centrifuge. In this type of centrifuge, sludge feed is introduced at the bottom of the basket, and solids collect at the bowl wall while clarified effluent overflows the lip ring at the top. Since the basket centrifuge does not have provision for continuous discharge of collected cake, operation requires interruption of the feed for cake discharge for a minute or two in a 10- to 30-minute overall cycle.

The third type of centrifuge commonly used in sludge dewatering is the conveyor type. Sludge is fed through a stationary feed pipe into a rotating bowl in which the solids are settled out against the bowl wall by centrifugal force. From the bowl wall, the solids are moved by a screw to the end of the machine, at which point they are discharged. The liquid effluent is discharged through ports after passing the length of the bowl under centrifugal force.

Application and Performance. Virtually all industrial waste treatment systems producing sludge can use centrifugation to dewater it. Centrifugation is currently being used by a wide range of industrial concerns.

The performance of sludge dewatering by centrifugation depends on the feed rate, the rotational velocity of the drum, and the sludge composition and concentration. Assuming proper design and operation, the solids content of the sludge can be increased to 20 to 35 percent.

Advantages and Limitations. Sludge dewatering centrifuges have minimal space requirements and show a high degree of effluent clarification. The operation is simple, clean, and relatively inexpensive. The area required for a centrifuge system installation is less than that required for a filter system or sludge drying bed of equal capacity, and the initial cost is lower.

Centrifuges have a high power cost that partially offsets the low initial cost. Special consideration must also be given to providing sturdy foundations and soundproofing because of the vibration and noise that result from centrifuge operation. Adequate electrical power must also be provided since large motors are required. The major difficulty encountered in the operation of centrifuges has been the disposal of the concentrate which is relatively high in suspended, nonsettling solids.

Operational Factors. Reliability: Centrifugation is highly reliable with proper control of factors such as sludge feed, consistency, and temperature. Pretreatment such as grit removal and coagulant addition may be necessary, depending on the composition of the sludge and on the type of centrifuge employed.

Maintainability: Maintenance consists of periodic lubrication, cleaning, and inspection. The frequency and degree of inspection required varies depending on the type of sludge solids being dewatered and the maintenance service conditions. If the sludge is abrasive, it is recommended that the first inspection of the rotating assembly be made after approximately 1,000 hours of operation. If the sludge is not abrasive or corrosive, then the initial inspection might be delayed. Centrifuges not equipped with a continuous sludge discharge system require periodic shutdowns for manual sludge cake removal.

Solid Waste Aspects: Sludge dewatered in the centrifugation process may be disposed of by landfill. The clarified effluent (centrate), if high in dissolved or suspended solids, may require further treatment prior to discharge.

Demonstration Status. Centrifugation is currently used in a great many commercial applications to dewater sludge. Work is underway to improve the efficiency, increase the capacity, and lower the costs associated with centrifugation.

11. Coalescing

The basic principle of coalescence involves the preferential wetting of a coalescing medium by oil droplets which accumulate

on the medium and then rise to the surface of the solution as they combine to form larger particles. The most important requirements for coalescing media are wettability for oil and large surface area. Monofilament line is sometimes used as a coalescing medium.

Coalescing stages may be integrated with a wide variety of gravity oil separation devices, and some systems may incorporate several coalescing stages. In general, a preliminary oil skimming step is desirable to avoid overloading the coalescer.

One commercially marketed system for oily waste treatment combines coalescing with inclined plate separation and filtration. In this system, the oily wastes flow into an inclined plate settler. This unit consists of a stack of inclined baffle plates in a cylindrical container with an oil collection chamber at the top. The oil droplets rise and impinge upon the undersides of the plates. They then migrate upward to a guide rib which directs the oil to the oil collection chamber, from which oil is discharged for reuse or disposal.

The oily water continues on through another cylinder containing replaceable filter cartridges, which remove suspended particles from the waste. From there the wastewater enters a final cylinder in which the coalescing material is housed. As the oily water passes through the many small, irregular, continuous passages in the coalescing material, the oil droplets coalesce and rise to an oil collection chamber.

Application and Performance. Coalescing is used to treat oily wastes which do not separate readily in simple gravity systems. The three-stage system described above has achieved effluent concentrations of 10 to 15 mg/l oil and grease from raw waste concentrations of 1000 mg/l or more.

Advantages and Limitations. Coalescing allows removal of oil droplets too finely dispersed for conventional gravity separation-skimming technology. It also can significantly reduce the residence times (and therefore separator volumes) required to achieve separation of oil from some wastes. Because of its simplicity, coalescing provides generally high reliability and low capital and operating costs. Coalescing is not generally effective in removing soluble or chemically stabilized emulsified oils. To avoid plugging, coalescers must be protected by pretreatment from very high concentrations of free oil and grease and suspended solids. Frequent replacement of prefilters may be necessary when raw waste oil concentrations are high.

Operational Factors. Reliability: Coalescing is inherently highly reliable since there are no moving parts, and the coalescing substrate (monofilament, etc.) is inert in the process and therefore not subject to frequent regeneration or replacement requirements. Large loads or inadequate pretreatment, however, may result in plugging or bypass of coalescing stages.

Maintainability: Maintenance requirements are generally limited to replacement of the coalescing medium on an infrequent basis.

Solid Waste Aspects: No appreciable solid waste is generated by this process.

Demonstration Status. Coalescing has been fully demonstrated in industries generating oily wastewater, although no nonferrous metals forming plants specifically reported their use.

12. Cyanide Oxidation by Chlorine

Cyanide oxidation using chlorine is widely used in industrial waste treatment to oxidize cyanide. Chlorine can be utilized in either the elemental or hypochlorite forms. This classic procedure can be illustrated by the following two step chemical reaction:

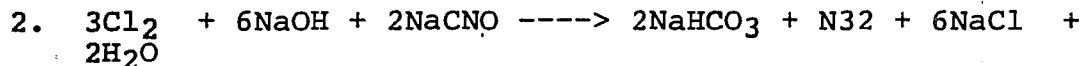
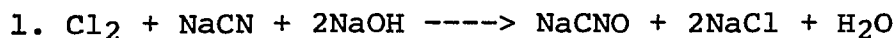

The reaction presented as Equation 2 for the oxidation of cyanate is the final step in the oxidation of cyanide. A complete system for the alkaline chlorination of cyanide is shown in Figure VII-19.

The alkaline chlorination process oxidizes cyanides to carbon dioxide and nitrogen. The equipment often consists of an equalization tank followed by two reaction tanks, although the reaction can be carried out in a single tank. Each tank has an electronic recorder-controller to maintain required conditions with respect to pH and oxidation reduction potential (ORP). In the first reaction tank, conditions are adjusted to oxidize cyanides to cyanates. To effect the reaction, chlorine is metered to the reaction tank as required to maintain the ORP in the range of 350 to 400 millivolts, and 50 percent aqueous caustic soda is added to maintain a pH range of 9.5 to 10. In the second reaction tank, conditions are maintained to oxidize cyanate to carbon dioxide and nitrogen. The desirable ORP and pH for this reaction are 600 millivolts and a pH of 8.0. Each of the reaction tanks is equipped with a propeller agitator designed to provide approximately one turnover per minute. Treatment by the batch process is accomplished by using two tanks, one for collection of water over a specified time period, and one for the treatment of an accumulated batch. If dumps of concentrated wastes are frequent, another tank may be required to equalize the flow to the treatment tank. When the holding tank is full, the liquid is transferred to the reaction tank for treatment. After treatment, the supernatant is discharged and the sludges are collected for removal and ultimate disposal.

Application and Performance. The oxidation of cyanide waste by chlorine is a classic process and is found in most industrial plants using cyanide. This process is capable of achieving effluent levels that are nondetectable. The process is potentially applicable to nonferrous metals forming facilities where cyanide is a component in wastewater.

Advantages and Limitations. Some advantages of chlorine oxidation for handling process effluents are operation at ambient temperature, suitability for automatic control, and low cost. Disadvantages include the need for careful pH control, possible chemical interference in the treatment of mixed wastes, and the potential hazard of storing and handling chlorine gas.

Operational Factors. Reliability: Chlorine oxidation is highly reliable with proper monitoring and control and proper pretreatment to control interfering substances.

Maintainability: Maintenance consists of periodic removal of sludge and recalibration of instruments.

Solid Waste Aspects: There is no solid waste problem associated with chlorine oxidation.

Demonstration Status. The oxidation of cyanide wastes by chlorine is a widely used process in plants using cyanide in cleaning and metal processing baths. Alkaline chlorination is also used for cyanide treatment in a number of inorganic chemical facilities producing hydrocyanic acid and various metal cyanides. One nonferrous metals forming plant is currently using this technology to treat process wastewaters.

13. Cyanide Oxidation By Ozone

Ozone is a highly reactive oxidizing agent which is approximately ten times more soluble than oxygen on a weight basis in water. Ozone may be produced by several methods, but the silent electrical discharge method is predominant in the field. The silent electrical discharge process produces ozone by passing oxygen or air between electrodes separated by an insulating material. A complete ozonation system is represented in Figure VII-20.

Application and Performance. Ozonation has been applied commercially to oxidize cyanides, phenolic chemicals, and organo-metal complexes. Its applicability to photographic wastewaters has been studied in the laboratory with good results. Ozone is used in industrial waste treatment primarily to oxidize cyanide to cyanate and to oxidize phenols and dyes to a variety of colorless nontoxic products.

Oxidation of cyanide to cyanate is illustrated below:

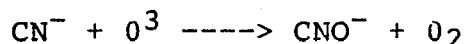

Continued exposure to ozone will convert the cyanate formed to carbon dioxide and ammonia; however, this is not economically practical.

Ozone oxidation of cyanide to cyanate requires 1.8 to 2.0 pounds ozone per pound of CN^- ; complete oxidation requires 4.6 to 5.0 pounds ozone per pound of CN^- . Zinc, copper, and nickel cyanides are easily destroyed to a nondetectable level, but cobalt and iron cyanides are more resistant to ozone treatment.

Advantages and Limitations. Some advantages of ozone oxidation for handling process effluents are its suitability to automatic control and on-site generation and the fact that reaction products are not chlorinated organics and no dissolved solids are added in the treatment step. Ozone in the presence of activated carbon, ultraviolet, and other promoters shows promise of reducing reaction time and improving ozone utilization, but the process at present is limited by high capital expense, possible chemical interference in the treatment of mixed wastes, and an energy requirement of 25 kwh/kg of ozone generated. Cyanide is not economically oxidized beyond the cyanate form.

Operational Factors. Reliability: Ozone oxidation is highly reliable with proper monitoring and control, and proper pretreatment to control interfering substances.

Maintainability: Maintenance consists of periodic removal of sludge, and periodic renewal of filters and desiccators required for the input of clean dry air; filter life is a function of input concentrations of detrimental constituents.

Solid Waste Aspects: Pretreatment to eliminate substances which will interfere with the process may be necessary. Dewatering of sludge generated in the ozone oxidation process or in an "in line" process may be desirable prior to disposal.

14. Cyanide Oxidation By Ozone With UV Radiation

One of the modifications of the ozonation process is the simultaneous application of ultraviolet light and ozone for the treatment of wastewater, including treatment of halogenated organics. The combined action of these two forms produces reactions by photolysis, photosensitization, hydroxylation, oxygenation, and oxidation. The process is unique because several reactions and reaction species are active simultaneously.

Ozonation is facilitated by ultraviolet absorption because both the ozone and the reactant molecules are raised to a higher energy state so that they react more rapidly. In addition, free radicals for use in the reaction are readily hydrolyzed by the water present. The energy and reaction intermediates created by the introduction of both ultraviolet and ozone greatly reduce the amount of ozone required compared with a system using ozone alone. Figure VII-21 shows a three-stage UV-ozone system. A system to treat mixed cyanides requires pretreatment that

involves chemical coagulation, sedimentation, clarification, equalization, and pH adjustment.

Application and Performance. The ozone-UV radiation process was developed primarily for cyanide treatment in the electroplating and color photo-processing areas. It has been successfully applied to mixed cyanides and organics from organic chemicals manufacturing processes. The process is particularly useful for treatment of complexed cyanides such as ferricyanide, copper cyanide, and nickel cyanide, which are resistant to ozone alone. Ozone combined with UV radiation is a relatively new technology. Four units are currently in operation, and all four treat cyanide bearing waste.

Ozone-UV treatment could be used in nonferrous metals forming plants to destroy cyanide present in some waste streams.

15. Cyanide Oxidation By Hydrogen Peroxide

Hydrogen peroxide oxidation removes both cyanide and metals in cyanide containing wastewaters. In this process, cyanide bearing waters are heated to 49 to 54C (120 to 130F) and the pH is adjusted to 10.5 to 11.8. Formalin (37 percent formaldehyde) is added while the tank is vigorously agitated. After 2 to 5 minutes, a proprietary peroxygen compound (41 percent hydrogen peroxide with a catalyst and additives) is added. After an hour of mixing, the reaction is complete. The cyanide is converted to cyanate, and the metals are precipitated as oxides or hydroxides. The metals are then removed from solution by either settling or filtration.

The main equipment required for this process is two holding tanks equipped with heaters and air spargers or mechanical stirrers. These tanks may be used in a batch or continuous fashion, with one tank being used for treatment while the other is being filled. A settling tank or a filter is needed to concentrate the precipitate.

Application and Performance. The hydrogen peroxide oxidation process is applicable to cyanide-bearing wastewaters, especially those containing metal-cyanide complexes. In terms of waste reduction performance, this process can reduce total cyanide to less than 0.1 mg/l and the zinc or cadmium to less than 1.0 mg/l.

Advantages and Limitations. Chemical costs are similar to those for alkaline chlorination using chlorine and lower than those for treatment with hypochlorite. All free cyanide reacts and is completely oxidized to the less toxic cyanate state. In addition, the metals precipitate and settle quickly, and they may be recoverable in many instances. However, the process requires energy expenditures to heat the wastewater prior to treatment.

Demonstration Status. This treatment process was introduced in 1971 and is used in several facilities. No nonferrous metals forming plants use oxidation by hydrogen peroxide.

16. Evaporation

Evaporation is a concentration process. Water is evaporated from a solution, increasing the concentration of solute in the remaining solution. If the resulting water vapor is condensed back to liquid water, the evaporation-condensation process is called distillation. However, to be consistent with industry terminology, evaporation is used in this report to describe both processes. Both atmospheric and vacuum evaporation are commonly used in industry today. Specific evaporation techniques are shown in Figure VII-22 and discussed below.

Atmospheric evaporation could be accomplished simply by boiling the liquid. However, to aid evaporation, heated liquid is sprayed on an evaporation surface, and air is blown over the surface and subsequently released to the atmosphere. Thus, evaporation occurs by humidification of the air stream, similar to a drying process. Equipment for carrying out atmospheric evaporation is quite similar for most applications. The major element is generally a packed column with an accumulator bottom. Accumulated wastewater is pumped from the base of the column, through a heat exchanger, and back into the top of the column, where it is sprayed into the packing. At the same time, air drawn upward through the packing by a fan is heated as it contacts the hot liquid. The liquid partially vaporizes and humidifies the air stream. The fan then blows the hot, humid air to the outside atmosphere. A scrubber is often unnecessary because the packed column itself acts as a scrubber.

Another form of atmospheric evaporator also works on the air humidification principle, but the evaporated water is recovered for reuse by condensation. These air humidification techniques operate well below the boiling point of water and can utilize waste process heat to supply the energy required.

In vacuum evaporation, the evaporation pressure is lowered to cause the liquid to boil at reduced temperature. All of the water vapor is condensed, and to maintain the vacuum condition, noncondensable gases (air in particular) are removed by a vacuum pump. Vacuum evaporation may be either single or double effect. In double effect evaporation, two evaporators are used, and the water vapor from the first evaporator (which may be heated by steam) is used to supply heat to the second evaporator. As it supplies heat, the water vapor from the first evaporator condenses. Approximately equal quantities of wastewater are evaporated in each unit; thus, the double effect system evaporates twice the amount of water that a single effect system does, at nearly the same cost in energy but with added capital cost and complexity. The double effect technique is thermodynamically possible because the second evaporator is maintained at lower pressure (higher vacuum) and, therefore, lower evaporation temperature. Vacuum evaporation equipment may be classified as submerged tube or climbing film evaporation units.

Another means of increasing energy efficiency is vapor recompression evaporation, which enables heat to be transferred from the condensing water vapor to the evaporating wastewater. Water vapor generated from incoming wastewaters flows to a vapor compressor. The compressed steam then travels through the wastewater via an enclosed tube or coil in which it condenses as heat is transferred to the surrounding solution. In this way, the compressed vapor serves as a heating medium. After condensation, this distillate is drawn off continuously as the clean water stream. The heat contained in the compressed vapor is used to heat the wastewater, and energy costs for system operation are reduced.

In the most commonly used submerged tube evaporator, the heating and condensing coil are contained in a single vessel to reduce capital cost. The vacuum in the vessel is maintained by an eductor-type pump, which creates the required vacuum by the flow of the condenser cooling water through a venturi. Wastewater accumulates in the bottom of the vessel, and it is evaporated by means of submerged steam coils. The resulting water vapor condenses as it contacts the condensing coils in the top of the vessel. The condensate then drips off the condensing coils into a collection trough that carries it out of the vessel. Concentrate is removed from the bottom of the vessel.

The major elements of the climbing film evaporator are the evaporator, separator, condenser, and vacuum pump. Wastewater is "drawn" into the system by the vacuum so that a constant liquid level is maintained in the separator. Liquid enters the steam-jacketed evaporator tubes, and part of it evaporates so that a mixture of vapor and liquid enters the separator. The design of the separator is such that the liquid is continuously circulated from the separator to the evaporator. The vapor entering the separator flows out through a mesh entrainment separator to the condenser, where it is condensed as it flows down through the condenser tubes. The condensate, along with any entrained air, is pumped out of the bottom of the condenser by a liquid ring vacuum pump. The liquid seal provided by the condensate keeps the vacuum in the system from being broken.

Application and Performance. Both atmospheric and vacuum evaporation are used in many industrial plants, mainly for the concentration and recovery of process solutions. Many of these evaporators also recover water for rinsing. Evaporation has also been applied to recovery of phosphate metal cleaning solutions.

In theory, evaporation should yield a concentrate and a deionized condensate. Actually, carry-over has resulted in condensate metal concentrations as high as 10 mg/l, although the usual level is less than 3 mg/l, pure enough for most final rinses. The condensate may also contain organic brighteners and antifoaming agents. These can be removed with an activated carbon bed, if necessary. Samples from one plant showed 1,900 mg/l zinc in the feed, 4,570 mg/l in the concentrate, and 0.4 mg/l in the

condensate. Another plant had 416 mg/l copper in the feed and 21,800 mg/l in the concentrate. Chromium analysis for that plant indicated 5,060 mg/l in the feed and 27,500 mg/l in the concentrate. Evaporators are available in a range of capacities, typically from 15 to 75 gph, and may be used in parallel arrangements for processing of higher flow rates.

Advantages and Limitations. Advantages of the evaporation process are that it permits recovery of a wide variety of process chemicals, and it is often applicable to concentration or removal of compounds which cannot be accomplished by any other means. The major disadvantage is that the evaporation process consumes relatively large amounts of energy for the evaporation of water. However, the recovery of waste heat from many industrial processes (e.g., diesel generators, incinerators, boilers and furnaces) should be considered as a source of this heat for a totally integrated evaporation system. Also, in some cases solar heating could be inexpensively and effectively applied to evaporation units. Capital costs for vapor compression evaporators are substantially higher than for other types of evaporation equipment. However, the energy costs associated with the operation of a vapor compression evaporator are significantly lower than costs of other evaporator types. For some applications, pretreatment may be required to remove solids or bacteria which tend to cause fouling in the condenser or evaporator. The buildup of scale on the evaporator surfaces reduces the heat transfer efficiency and may present a maintenance problem or increase operating cost. However, it has been demonstrated that fouling of the heat transfer surfaces can be avoided or minimized for certain dissolved solids by maintaining a seed slurry which provides preferential sites for precipitate deposition. In addition, low temperature differences in the evaporator will eliminate nucleate boiling and supersaturation effects. Steam distillable impurities in the process stream are carried over with the product water and must be handled by pre- or post-treatment.

Operational Factors. Reliability: Proper maintenance will ensure a high degree of reliability for the system. Without such attention, rapid fouling or deterioration of vacuum seals may occur, especially when corrosive liquids are handled.

Maintainability: Operating parameters can be automatically controlled. Pretreatment may be required, as well as periodic cleaning of the system. Regular replacement of seals, especially in a corrosive environment, may be necessary.

Solid Waste Aspects: With only a few exceptions, the process does not generate appreciable quantities of solid waste.

Demonstration Status. Evaporation is a fully developed, commercially available wastewater treatment system. It is used extensively to recover plating chemicals in the electroplating industry, and a pilot scale unit has been used in connection with phosphating of aluminum. Proven performance in silver recovery

indicates that evaporation could be a useful treatment operation for the photographic industry, as well as for metal finishing. Vapor compression evaporation has been practically demonstrated in a number of industries, including chemical manufacturing, food processing, pulp and paper, and metal working.

17. Flotation

Flotation is the process of causing particles such as metal hydroxides or oil to float to the surface of a tank where they can be concentrated and removed. This is accomplished by releasing gas bubbles which attach to the solid particles, increasing their buoyancy and causing them to float. In principle, this process is the opposite of sedimentation. Figure VII-23 shows one type of flotation system.

Flotation is used primarily in the treatment of wastewater streams that carry heavy loads of finely divided suspended solids or oil. Solids having a specific gravity only slightly greater than 1.0, which would require abnormally long sedimentation times, may be removed in much less time by flotation. Dissolved air flotation is of greatest interest in removing oil from water and is less effective in removing heavier precipitates.

This process may be performed in several ways: foam, dispersed air, dissolved air, gravity, and vacuum flotation are the most commonly used techniques. Chemical additives are often used to enhance the performance of the flotation process.

The principal difference among types of flotation is the method of generating the minute gas bubbles (usually air) in a suspension of water and small particles. Chemicals may be used to improve the efficiency with any of the basic methods. The following paragraphs describe the different flotation techniques and the method of bubble generation for each process.

Froth Flotation - Froth flotation is based on differences in the physiochemical properties in various particles. Wettability and surface properties affect the particles' ability to attach themselves to gas bubbles in an aqueous medium. In froth flotation, air is blown through the solution containing flotation reagents. The particles with water repellent surfaces stick to air bubbles as they rise and are brought to the surface. A mineralized froth layer, with mineral particles attached to air bubbles, is formed. Particles of other minerals which are readily wetted by water do not stick to air bubbles and remain in suspension.

Dispersed Air Flotation - In dispersed air flotation, gas bubbles are generated by introducing the air by means of mechanical agitation with impellers or by forcing air through porous media. Dispersed air flotation is used mainly in the metallurgical industry.

Dissolved Air Flotation - In dissolved air flotation, bubbles are produced by releasing air from a supersaturated solution under relatively high pressure. There are two types of contact between the gas bubbles and particles. The first type is predominant in the flotation of flocculated materials and involves the entrapment of rising gas bubbles in the flocculated particles as they increase in size. The bond between the bubble and particle is one of physical capture only. The second type of contact is one of adhesion. Adhesion results from the intermolecular attraction exerted at the interface between the solid particle and gaseous bubble.

Vacuum Flotation - This process consists of saturating the wastewater with air either directly in an aeration tank, or by permitting air to enter on the suction of a wastewater pump. A partial vacuum is applied, which causes the dissolved air to come out of solution as minute bubbles. The bubbles attach to solid particles and rise to the surface to form a scum blanket, which is normally removed by a skimming mechanism. Grit and other heavy solids that settle to the bottom are generally raked to a central sludge pump for removal. A typical vacuum flotation unit consists of a covered cylindrical tank in which a partial vacuum is maintained. The tank is equipped with scum and sludge removal mechanisms. The floating material is continuously swept to the tank periphery, automatically discharged into a scum trough, and removed from the unit by a pump also under partial vacuum. Auxiliary equipment includes an aeration tank for saturating the wastewater with air, a tank with a short retention time for removal of large bubbles, vacuum pumps, and sludge pumps.

Application and Performance. The primary variables for flotation design are pressure, feed solids concentration, and retention period. The suspended solids in the effluent decrease, and the concentration of solids in the float increases with increasing retention period. When the flotation process is used primarily for clarification, a retention period of 20 to 30 minutes usually is adequate for separation and concentration.

Advantages and Limitations. Some advantages of the flotation process are the high levels of solids separation achieved in many applications, the relatively low energy requirements, and the adaptability to meet the treatment requirements of different waste types. Limitations of flotation are that it often requires addition of chemicals to enhance process performance and that it generates large quantities of solid waste.

Operational Factors. **Reliability:** Flotation systems normally are very reliable with proper maintenance of the sludge collector mechanism and the motors and pumps used for aeration.

Maintainability: Routine maintenance is required on the pumps and motors. The sludge collector mechanism is subject to possible corrosion or breakage and may require periodic replacement.

Solid Waste Aspects: Chemicals are commonly used to aid the flotation process by creating a surface or a structure that can easily adsorb or entrap air bubbles. Inorganic chemicals, such as the aluminum and ferric salts, and activated silica, can bind the particulate matter together and create a structure that can entrap air bubbles. Various organic chemicals can change the nature of either the air-liquid interface or the solid-liquid interface, or both. These compounds usually collect on the interface to bring about the desired changes. The added chemicals plus the particles in solution combine to form a large volume of sludge which must be further treated or properly disposed.

Demonstration Status. Flotation is a fully developed process and is readily available for the treatment of a wide variety of industrial waste streams.

18. Gravity Sludge Thickening

In the gravity thickening process, dilute sludge is fed from a primary settling tank or clarifier to a thickening tank where rakes stir the sludge gently to densify it and to push it to a central collection well. The supernatant is returned to the primary settling tank. The thickened sludge that collects on the bottom of the tank is pumped to dewatering equipment or hauled away. Figure VII-24 shows the construction of a gravity thickener.

Application and Performance. Thickeners are generally used in facilities where the sludge is to be further dewatered by a compact mechanical device such as a vacuum filter or centrifuge. Doubling the solids content in the thickener substantially reduces capital and operating cost of the subsequent dewatering device and also reduces cost for hauling. The process is potentially applicable to almost any industrial plant.

Organic sludges from sedimentation units of one to two percent solids concentration can usually be gravity thickened to six to ten percent; chemical sludges can be thickened to four to six percent.

Advantages and Limitations. The principal advantage of a gravity sludge thickening process is that it facilitates further sludge dewatering. Other advantages are high reliability and minimum maintenance requirements.

Limitations of the sludge thickening process are its sensitivity to the flow rate through the thickener and the sludge removal rate. These rates must be low enough not to disturb the thickened sludge.

Operational Factors. Reliability: Reliability is high with proper design and operation. A gravity thickener is designed on the basis of square feet per pound of solids per day, in which the required surface area is related to the solids entering and

leaving the unit. Thickener area requirements are also expressed in terms of mass loading, grams of solids per square meter per day (lbs/sq ft/day).

Maintainability: Twice a year, a thickener must be shut down for lubrication of the drive mechanisms. Occasionally, water must be pumped back through the system in order to clear sludge pipes.

Solid Waste Aspects: Thickened sludge from a gravity thickening process will usually require further dewatering prior to disposal, incineration, or drying. The clear effluent may be recirculated in part, or it may be subjected to further treatment prior to discharge.

Demonstration Status. Gravity sludge thickeners are used throughout industry to reduce water content to a level where the sludge may be efficiently handled. Further dewatering is usually practiced to minimize costs of hauling the sludge to approved landfill areas.

19. Insoluble Starch Xanthate

Insoluble starch xanthate is essentially an ion exchange medium used to remove dissolved heavy metals from wastewater. The water may then either be reused (recovery application) or discharged (end-of-pipe application). In a commercial electroplating operation, starch xanthate is coated on a filter medium. Rinse water containing dragged out heavy metals is circulated through the filters and then reused for rinsing. The starch-heavy metal complex is disposed of and replaced periodically. Laboratory tests indicate that recovery of metals from the complex is feasible, with regeneration of the starch xanthate. Besides electroplating, starch xanthate is potentially applicable to any other industrial plants where dilute metal wastewater streams are generated. Its present use is limited to one electroplating plant.

20. Ion Exchange

Ion exchange is a process in which ions, held by electrostatic forces to charged functional groups on the surface of the ion exchange resin, are exchanged for ions of similar charge from the solution in which the resin is immersed. This is classified as a sorption process because the exchange occurs on the surface of the resin, and the exchanging ion must undergo a phase transfer from solution phase to solid phase. Thus, ionic contaminants in a waste stream can be exchanged for the harmless ions of the resin.

Although the precise technique may vary slightly according to the application involved, a generalized process description follows. The wastewater stream being treated passes through a filter to remove any solids, then flows through a cation exchanger which contains the ion exchange resin. Here, metallic impurities such as copper, iron, and trivalent chromium are retained. The stream

then passes through the anion exchanger and its associated resin. Hexavalent chromium, for example, is retained in this stage. If one pass does not reduce the contaminant levels sufficiently, the stream may then enter another series of exchangers. Many ion exchange systems are equipped with more than one set of exchangers for this reason. A strongly basic anion exchange resin may be used alone to remove precious metals, such as gold, palladium and platinum.

The other major portion of the ion exchange process concerns the regeneration of the resin, which now holds those impurities retained from the waste stream. An ion exchange unit with in-place regeneration is shown in Figure VII-25. Metal ions such as nickel are removed by an acid, cation exchange resin, which is regenerated with hydrochloric or sulfuric acid, replacing the metal ion with one or more hydrogen ions. Anions such as dichromate are removed by a basic, anion exchange resin, which is regenerated with sodium hydroxide, replacing the anion with one or more hydroxyl ions. The three principal methods employed by industry for regenerating the spent resin are:

- A) Replacement Service: A regeneration service replaces the spent resin with regenerated resin, and regenerates the spent resin at its own facility. The service then has the problem of treating and disposing of the spent regenerant.
- B) In-Place Regeneration: Some establishments may find it less expensive to do their own regeneration. The spent resin column is shut down for perhaps an hour, and the spent resin is regenerated. This results in one or more waste streams which must be treated in an appropriate manner. Regeneration is performed as the resins require it, usually every few months.
- C) Cyclic Regeneration: In this process, the regeneration of the spent resins takes place within the ion exchange unit itself in alternating cycles with the ion removal process. A regeneration frequency of twice an hour is typical. This very short cycle time permits operation with a very small quantity of resin and with fairly concentrated solutions, resulting in a very compact system. Again, this process varies according to application, but the regeneration cycle generally begins with caustic being pumped through the anion exchanger, carrying out hexavalent chromium, for example, as sodium dichromate. The sodium dichromate stream then passes through a cation exchanger, converting the sodium dichromate to chromic acid. After concentration by evaporation or other means, the chromic acid can be returned to the process line. Meanwhile, the cation exchanger is regenerated with sulfuric acid, resulting in a waste acid stream containing the metallic impurities removed earlier.

Flushing the exchangers with water completes the cycle. Thus, the wastewater is purified and, in this example, chromic acid is recovered. The ion exchangers, with newly regenerated resin, then enter the ion removal cycle again.

Application and Performance. The list of pollutants for which the ion exchange system has proved effective includes aluminum, arsenic, cadmium, chromium (hexavalent and trivalent), copper, cyanide, gold, iron, lead, manganese, nickel, platinum and palladium, selenium, silver, tin, zinc, and more. Thus, it can be applied to a wide variety of industrial concerns. Because of the heavy concentrations of metals in their wastewater, the metal finishing industries utilize ion exchange in several ways. As an end-of-pipe treatment, ion exchange is certainly feasible, but its greatest value is in recovery applications. It is commonly used as an integrated treatment to recover rinse water and process chemicals. Some electroplating facilities use ion exchange to concentrate and purify plating baths. Also, many industrial concerns use ion exchange to reduce salt concentrations in incoming water sources.

Ion exchange is highly efficient at recovering metal bearing solutions. Recovery of chromium, nickel, phosphate solution, and sulfuric acid from anodizing is common. A chromic acid recovery efficiency of 99.5 percent has been demonstrated. Typical data for purification of rinse water have been reported and are displayed in Table VII-26. Sampling at a nonferrous metals manufacturing battery manufacturing plant characterized influent and effluent streams for an ion exchange unit on a silver bearing waste. This system was in start-up at the time of sampling, however, and was not found to be operating effectively.

Advantages and Limitations. Ion exchange is a versatile technology applicable to a great many situations. This flexibility, along with its compact nature and performance, makes ion exchange a very effective method of wastewater treatment. However, the resins in these systems can prove to be a limiting factor. The thermal limits of the anion resins, generally in the vicinity of 60C, could prevent its use in certain situations. Similarly, nitric acid, chromic acid, and hydrogen peroxide can all damage the resins, as will iron, manganese, and copper when present with sufficient concentrations of dissolved oxygen. Removal of a particular trace contaminant may be uneconomical because of the presence of other ionic species that are preferentially removed. The regeneration of the resins presents its own problems. The cost of the regenerative chemicals can be high. In addition, the waste streams originating from the regeneration process are extremely high in pollutant concentrations, although low in volume. These must be further processed for proper disposal.

Operational Factors. Reliability: With the exception of occasional clogging or fouling of the resins, ion exchange has proved to be a highly dependable technology.

Maintainability: Only the normal maintenance of pumps, valves, piping and other hardware used in the regeneration process is required.

Solid Waste Aspects: Few, if any, solids accumulate within the ion exchangers, and those which do appear are removed by the regeneration process. Proper prior treatment and planning can eliminate solids buildup problems altogether. The brine resulting from regeneration of the ion exchange resin usually must be treated to remove metals before discharge. This can generate solid waste.

Demonstration Status. All of the applications mentioned in this document are available for commercial use, and industry sources estimate the number of units currently in the field at well over 120. The research and development in ion exchange is focusing on improving the quality and efficiency of the resins, rather than new applications. Work is also being done on a continuous regeneration process whereby the resins are contained on a fluid-transfusible belt. The belt passes through a compartmentalized tank with ion exchange, washing, and regeneration sections. The resins are therefore continually used and regenerated. No such system, however, has been reported beyond the pilot stage.

21. Membrane Filtration

Membrane filtration is a treatment system for removing precipitated metals from a wastewater stream. It must therefore be preceded by those treatment techniques which will properly prepare the wastewater for solids removal. Typically, a membrane filtration unit is preceded by pH adjustment or sulfide addition for precipitation of the metals. These steps are followed by the addition of a proprietary chemical reagent which causes the precipitate to be nongelatinous, easily dewatered, and highly stable. The resulting mixture of pretreated wastewater and reagent is continuously recirculated through a filter module and back into a recirculation tank. The filter module contains tubular membranes. While the reagent-metal hydroxide precipitate mixture flows through the inside of the tubes, the water and any dissolved salts permeate the membrane. When the recirculating slurry reaches a concentration of 10 to 15 percent solids, it is pumped out of the system as sludge.

Application and Performance. Membrane filtration appears to be applicable to any wastewater or process water containing metal ions which can be precipitated using hydroxide, sulfide or carbonate precipitation. It could function as the primary treatment system, but also might find application as a polishing treatment (after precipitation and settling) to ensure continued compliance with metals limitations. Membrane filtration systems are being used in a number of industrial applications,

particularly in the metal finishing area. They have also been used for toxic metals removal in the metal fabrication industry and the paper industry.

The permeate is claimed by one manufacturer to contain less than the effluent concentrations shown in Table VII-27 regardless of the influent concentrations. These claims have been largely substantiated by the analysis of water samples at various plants in various industries.

In the performance predictions for this technology, pollutant concentrations are reduced to the levels shown in Table VII-27 unless lower levels are present in the influent stream.

Advantages and Limitations. A major advantage of the membrane filtration system is that installations can use most of the conventional end-of-pipe systems that may already be in place. Removal efficiencies are claimed to be excellent, even with sudden variation of pollutant input rates; however, the effectiveness of the membrane filtration system can be limited by clogging of the filters. Because pH changes in the waste stream greatly intensify clogging problems, the pH must be carefully monitored and controlled. Clogging can force the shutdown of the system and may interfere with production. In addition, the relatively high capital cost of this system may limit its use.

Operational Factors. Reliability: Membrane filtration has been shown to be a very reliable system, provided that the pH is strictly controlled. Improper pH can result in the clogging of the membrane. Also, surges in the flow rate of the waste stream must be controlled in order to prevent solids from passing through the filter and into the effluent.

Maintainability: The membrane filters must be regularly monitored, and cleaned or replaced as necessary. Depending on the composition of the waste stream and its flow rate, frequent cleaning of the filters may be required. Flushing with hydrochloric acid for 6 to 24 hours will usually suffice. In addition, the routine maintenance of pumps, valves, and other plumbing is required.

Solid Waste Aspects: When the recirculating reagent-precipitate slurry reaches 10 to 15 percent solids, it is pumped out of the system. It can then be disposed of directly or it can undergo a dewatering process. Because this sludge contains toxic metals, it requires proper disposal.

Demonstration Status. There are more than 25 membrane filtration systems presently in use on metal finishing and similar wastewaters. Bench scale and pilot studies are being run in an attempt to expand the list of pollutants for which this system is known to be effective.

22. Peat Adsorption

Peat moss is a complex natural organic material containing lignin and cellulose as major constituents. These constituents, particularly lignin, bear polar functional groups, such as alcohols, aldehydes, ketones, acids, phenolic hydroxides, and ethers, that can be involved in chemical bonding. Because of the polar nature of the material, its adsorption of dissolved solids such as transition metals and polar organic molecules is quite high. These properties have led to the use of peat as an agent for the purification of industrial wastewater.

Peat adsorption is a "polishing" process which can achieve very low effluent concentrations for several pollutants. If the concentrations of pollutants are above 10 mg/l, then peat adsorption must be preceded by pH adjustment for metals precipitation and subsequent clarification. Pretreatment is also required for chromium wastes using ferric chloride and sodium sulfide. The wastewater is then pumped into a large metal chamber called a kier which contains a layer of peat through which the waste stream passes. The water flows to a second kier for further adsorption. The wastewater is then ready for discharge. This system may be automated or manually operated.

Application and Performance. Peat adsorption can be used in nonferrous metals forming for removal of residual dissolved metals from clarifier effluent. Peat moss may be used to treat wastewaters containing heavy metals such as mercury, cadmium, zinc, copper, iron, nickel, chromium, and lead, as well as organic matter such as oil, detergents, and dyes. Peat adsorption is currently used commercially at a textile plant, a newsprint facility, and a metal reclamation operation.

Table VII-28 contains performance figures obtained from pilot plant studies. Peat adsorption was preceded by pH adjustment for precipitation and by clarification.

In addition, pilot plant studies have shown that chelated metal wastes, as well as the chelating agents themselves, are removed by contact with peat moss.

Advantages and Limitations. The major advantages of the system include its ability to yield low pollutant concentrations, its broad scope in terms of the pollutants eliminated, and its capacity to accept wide variations of waste water composition.

Limitations include the cost of purchasing, storing, and disposing of the peat moss; the necessity for regular replacement of the peat may lead to high operation and maintenance costs. Also, the pH adjustment must be altered according to the composition of the waste stream.

Operational Factors. Reliability: The question of long term reliability is not yet fully answered. Although the manufacturer

reports it to be a highly reliable system, operating experience is needed to verify the claim.

Maintainability: The peat moss used in this process soon exhausts its capacity to adsorb pollutants. At that time, the kiers must be opened, the peat removed, and fresh peat placed inside. Although this procedure is easily and quickly accomplished, it must be done at regular intervals, or the system's efficiency drops drastically.

Solid Waste Aspects: After removal from the kier, the spent peat must be eliminated. If incineration is used, precautions should be taken to insure that those pollutants removed from the water are not released again in the combustion process. Presence of sulfides in the spent peat, for example, will give rise to sulfur dioxide in the fumes from burning. The presence of significant quantities of toxic heavy metals in battery manufacturing wastewater will in general preclude incineration of peat used in treating these wastes.

Demonstration Status. Only three facilities currently use commercial adsorption systems in the United States - a textile manufacturer, a newsprint facility, and a metal reclamation firm. No data have been reported showing the use of peat adsorption in nonferrous metals forming plants.

23. Reverse Osmosis

The process of osmosis involves the passage of a liquid through a semipermeable membrane from a dilute to a more concentrated solution. Reverse osmosis (RO) is an operation in which pressure is applied to the more concentrated solution, forcing the permeate to diffuse through the membrane and into the more dilute solution. This filtering action produces a concentrate and a permeate on opposite sides of the membrane. The concentrate can then be further treated or returned to the original operation for continued use, while the permeate water can be recycled for use as clean water. Figure VII-26 depicts a reverse osmosis system.

As illustrated in Figure VII-27, there are three basic configurations used in commercially available RO modules: tubular, spiral-wound, and hollow fiber. All of these operate on the principle described above, the major difference being their mechanical and structural design characteristics.

The tubular membrane module uses a porous tube with a cellulose acetate membrane lining. A common tubular module consists of a length of 2.5 cm (1 inch) diameter tube wound on a supporting spool and encased in a plastic shroud. Feed water is driven into the tube under pressures varying from 40 to 55 atm (600-800 psi). The permeate passes through the walls of the tube and is collected in a manifold while the concentrate is drained off at the end of the tube. A less widely used tubular RO module uses a

straight tube contained in a housing, under the same operating conditions.

Spiral-wound membranes consist of a porous backing sandwiched between two cellulose acetate membrane sheets and bonded along three edges. The fourth edge of the composite sheet is attached to a large permeate collector tube. A spacer screen is then placed on top of the membrane sandwich, and the entire stack is rolled around the centrally located tubular permeate collector. The rolled up package is inserted into a pipe able to withstand the high operating pressures employed in this process, up to 55 atm (800 psi) with the spiral-wound module. When the system is operating, the pressurized product water permeates the membrane and flows through the backing material to the central collector tube. The concentrate is drained off at the end of the container pipe and can be reprocessed or sent to further treatment facilities.

The hollow fiber membrane configuration is made up of a bundle of polyamide fibers of approximately 0.0075 cm (0.003 in.) OD and 0.0043 cm (0.0017 in.) ID. A commonly used hollow fiber module contains several hundred thousand of the fibers placed in a long tube, wrapped around a flow screen, and rolled into a spiral. The fibers are bent in a U-shape and their ends are supported by an epoxy bond. The hollow fiber unit is operated under 27 atm (400 psi), the feed water being dispersed from the center of the module through a porous distributor tube. Permeate flows through the membrane to the hollow interiors of the fibers and is collected at the ends of the fibers.

The hollow fiber and spiral-wound modules have a distinct advantage over the tubular system in that they are able to load a very large membrane surface area into a relatively small volume. However, these two membrane types are much more susceptible to fouling than the tubular system, which has a larger flow channel.

This characteristic also makes the tubular membrane much easier to clean and regenerate than either the spiral-wound or hollow fiber modules. One manufacturer claims that their helical tubular module can be physically wiped clean by passing a soft porous polyurethane plug under pressure through the module.

Application and Performance. In a number of metal processing plants, the overflow from the first rinse in a countercurrent setup is directed to a reverse osmosis unit, where it is separated into two streams. The concentrated stream contains dragged out chemicals and is returned to the bath to replace the loss of solution caused by evaporation and dragout. The dilute stream (the permeate) is routed to the last rinse tank to provide water for the rinsing operation. The rinse flows from the last tank to the first tank, and the cycle is complete.

The closed-loop system described above may be supplemented by the addition of a vacuum evaporator after the RO unit in order to further reduce the volume of reverse osmosis concentrate. The

evaporated vapor can be condensed and returned to the last rinse tank or sent on for further treatment.

The largest application has been for the recovery of nickel solutions. It has been shown that RO can generally be applied to most acid metal baths with a high degree of performance, providing that the membrane unit is not overtaxed. The limitations most critical here are the allowable pH range and maximum operating pressure for each particular configuration. Adequate prefiltration is also essential. Only three membrane types are readily available in commercial RO units, and their overwhelming use has been for the recovery of various acid metal baths. For the purpose of calculating performance predictions of this technology, a rejection ratio of 98 percent is assumed for dissolved salts, with 95 percent permeate recovery.

Advantages and Limitations. The major advantage of reverse osmosis for handling process effluents is its ability to concentrate dilute solutions for recovery of salts and chemicals with low power requirements. No latent heat of vaporization or fusion is required for effecting separations; the main energy requirement is for a high pressure pump. It requires relatively little floor space for compact, high capacity units, and it exhibits good recovery and rejection rates for a number of typical process solutions. A limitation of the reverse osmosis process for treatment of process effluents is its limited temperature range for satisfactory operation. For cellulose acetate systems, the preferred limits are 18 to 30C (65 to 85F); higher temperatures will increase the rate of membrane hydrolysis and reduce system life, while lower temperatures will result in decreased fluxes with no damage to the membrane. Another limitation is inability to handle certain solutions. Strong oxidizing agents, strongly acidic or basic solutions, solvents, and other organic compounds can cause dissolution of the membrane. Poor rejection of some compounds such as borates and low molecular weight organics is another problem. Fouling of membranes by slightly soluble components in solution or colloids has caused failures, and fouling of membranes by feed waters with high levels of suspended solids can be a problem. A final limitation is inability to treat or achieve high concentration with some solutions. Some concentrated solutions may have initial osmotic pressures which are so high that they either exceed available operating pressures or are uneconomical to treat.

Operational Factors. Reliability: Very good reliability is achieved so long as the proper precautions are taken to minimize the chances of fouling or degrading the membrane. Sufficient testing of the waste stream prior to application of an RO system will provide the information needed to insure a successful application.

Maintainability: Membrane life is estimated to range from six months to three years, depending on the use of the system. Downtime for flushing or cleaning is on the order of two hours as

often as once each week; a substantial portion of maintenance time must be spent on cleaning any prefilters installed ahead of the reverse osmosis unit.

Solid Waste Aspects: In a closed loop system utilizing RO, there is a constant recycle of concentrate and a minimal amount of solid waste. Prefiltration eliminates many solids before they reach the module and helps keep the buildup to a minimum. These solids require proper disposal.

Demonstration Status. There are presently at least one hundred reverse osmosis wastewater applications in a variety of industries. In addition to these, there are 30 to 40 units being used to provide pure process water for several industries. Despite the many types and configurations of membranes, only the spiral-wound cellulose acetate membrane has had widespread success in commercial applications.

24. Sludge Bed Drying

As a waste treatment procedure, sludge bed drying is employed to reduce the water content of a variety of sludges to the point where they are amenable to mechanical collection and removal to landfill. These beds usually consist of 15 to 45 cm (6 to 18 in.) of sand over a 30 cm (12 in.) deep gravel drain system made up of 3 to 6 mm (1/8 to 1/4 in.) graded gravel overlying drain tiles. Figure VII-28 shows the construction of a drying bed.

Drying beds are usually divided into sectional areas approximately 7.5 meters (25 ft) wide x 30 to 60 meters (100 to 200 ft) long. The partitions may be earth embankments, but more often are made of planks and supporting grooved posts.

To apply liquid sludge to the sand bed, a closed conduit or a pressure pipeline with valved outlets at each sand bed section is often employed. Another method of application is by means of an open channel with appropriately placed side openings which are controlled by slide gates. With either type of delivery system, a concrete splash slab should be provided to receive the falling sludge and prevent erosion of the sand surface.

Where it is necessary to dewater sludge continuously throughout the year regardless of the weather, sludge beds may be covered with a fiberglass reinforced plastic or other roof. Covered drying beds permit a greater volume of sludge drying per year in most climates because of the protection afforded from rain or snow and because of more efficient control of temperature. Depending on the climate, a combination of open and enclosed beds will provide maximum utilization of the sludge bed drying facilities.

Application and Performance. Sludge drying beds are a means of dewatering sludge from clarifiers and thickeners. They are

widely used both in municipal and industrial treatment facilities.

Dewatering of sludge on sand beds occurs by two mechanisms: filtration of water through the bed and evaporation of water as a result of radiation and convection. Filtration is generally complete in one to two days and may result in solids concentrations as high as 15 to 20 percent. The rate of filtration depends on the drainability of the sludge.

The rate of air drying of sludge is related to temperature, relative humidity, and air velocity. Evaporation will proceed at a constant rate to a critical moisture content, then at a falling rate to an equilibrium moisture content. The average evaporation rate for a sludge is about 75 percent of that from a free water surface.

Advantages and Limitations. The main advantage of sludge drying beds over other types of sludge dewatering is the relatively low cost of construction, operation, and maintenance.

Its disadvantages are the large area of land required and long drying times that depend, to a great extent, on climate and weather.

Operational Factors. Reliability: Reliability is high with favorable climatic conditions, proper bed design and care to avoid excessive or unequal sludge application. If climatic conditions in a given area are not favorable for adequate drying, a cover may be necessary.

Maintainability: Maintenance consists basically of periodic removal of the dried sludge. Sand removed from the drying bed with the sludge must be replaced and the sand layer resurfaced.

The resurfacing of sludge beds is the major expense item in sludge bed maintenance, but there are other areas which may require attention. Underdrains occasionally become clogged and have to be cleaned. Valves or sludge gates that control the flow of sludge to the beds must be kept watertight. Provision for drainage of lines in winter should be provided to prevent damage from freezing. The partitions between beds should be tight so that sludge will not flow from one compartment to another. The outer walls or banks around the beds should also be watertight.

Solid Waste Aspects: The full sludge drying bed must either be abandoned or the collected solids must be removed to a landfill. These solids contain whatever metals or other materials were settled in the clarifier. Metals will be present as hydroxides, oxides, sulfides, or other salts. They have the potential for leaching and contaminating ground water, whatever the location of the semidried solids. Thus the abandoned bed or landfill should include provision for runoff control and leachate monitoring.

Demonstration Status. Sludge beds have been in common use in both municipal and industrial facilities for many years. However, protection of ground water from contamination is not always adequate.

25. Ultrafiltration

Ultrafiltration (UF) is a process which uses semipermeable polymeric membranes to separate emulsified or colloidal materials suspended in a liquid phase by pressurizing the liquid so that it permeates the membrane. The membrane of an ultrafilter forms a molecular screen which retains molecular particles based on their differences in size, shape, and chemical structure. The membrane permits passage of solvents and lower molecular weight molecules. At present, an ultrafilter is capable of removing materials with molecular weights in the range of 1,000 to 100,000 and particles of comparable or larger sizes.

In an ultrafiltration process, the feed solution is pumped through a tubular membrane unit. Water and some low molecular weight materials pass through the membrane under the applied pressure of 2 to 8 atm (10 to 100 psig). Emulsified oil droplets and suspended particles are retained, concentrated, and removed continuously. In contrast to ordinary filtration, retained materials are washed off the membrane filter rather than held by it. Figure VII-29 represents the ultrafiltration process. Figure VII-34 shows a flow diagram for a batch treatment ultrafiltration system.

Application and Performance. Ultrafiltration has potential application to nonferrous metals forming wastewater for separation of oils and residual solids from a variety of waste streams. In treating nonferrous metals forming wastewater, its greatest applicability would be as a polishing treatment to remove residual precipitated metals after chemical precipitation and clarification. Successful commercial use, however, has been primarily for separation of emulsified oils from wastewater. Over one hundred such units now operate in the United States, treating emulsified oils from a variety of industrial processes. Capacities of currently operating units range from a few hundred gallons a week to 50,000 gallons per day. Concentration of oily emulsions to 60 percent oil or more is possible. Oil concentrates of 40 percent or more are generally suitable for incineration, and the permeate can be treated further and in some cases recycled back to the process. In this way, it is possible to eliminate contractor removal costs for oil from some oily waste streams.

The test data in Table VII-29 indicate ultrafiltration performance (note that UF is not intended to remove dissolved solids). The removal percentages shown are typical, but they can be influenced by pH and other conditions.

The permeate or effluent from the ultrafiltration unit is normally of a quality that can be reused in industrial

applications or discharged directly. The concentrate from the ultrafiltration unit can be disposed of as any oily or solid waste.

Advantages and Limitations. Ultrafiltration is sometimes an attractive alternative to chemical treatment because of lower capital equipment, installation, and operating costs, very high oil and suspended solids removal, and little required pretreatment. It places a positive barrier between pollutants and effluent which reduces the possibility of extensive pollutant discharge due to operator error or upset in settling and skimming systems. Alkaline values in alkaline cleaning solutions can be recovered and reused in process.

A limitation of ultrafiltration for treatment of process effluents is its narrow temperature range (18 to 30C) for satisfactory operation. Membrane life decreases with higher temperatures, but flux increases at elevated temperatures. Therefore, surface area requirements are a function of temperature and become a trade-off between initial costs and replacement costs for the membrane. In addition, ultrafiltration cannot handle certain solutions. Strong oxidizing agents, solvents, and other organic compounds can dissolve the membrane. Fouling is sometimes a problem, although the high velocity of the wastewater normally creates enough turbulence to keep fouling at a minimum. Large solids particles can sometimes puncture the membrane and therefore must be removed by gravity settling or filtration prior to the ultrafiltration unit.

Operational Factors. Reliability: The reliability of an ultrafiltration system is dependent on the proper filtration, settling or other treatment of incoming waste streams to prevent damage to the membrane. Careful pilot studies should be done in each instance to determine necessary pretreatment steps and the exact membrane type to be used.

Maintainability: A limited amount of regular maintenance is required for the pumping system. In addition, membranes must be periodically changed. Maintenance associated with membrane plugging can be reduced by selection of a membrane with optimum physical characteristics and sufficient velocity of the waste stream. It is occasionally necessary to pass a detergent solution through the system to remove an oil and grease film which accumulates on the membrane. With proper maintenance, membrane life can be greater than twelve months.

Solid Waste Aspects: Ultrafiltration is used primarily to recover solids and liquids. It therefore eliminates solid waste problems when the solids (e.g., paint solids) can be recycled to the process. Otherwise, the stream containing solids must be treated by end-of-pipe equipment. In the most probable applications within the nonferrous metals forming category,

the ultrafilter would remove hydroxides or sulfides of metals which have recovery value.

Demonstration Status. The ultrafiltration process is well developed and commercially available for treatment of wastewater or recovery of certain high molecular weight liquid and solid contaminants. One nonferrous metals forming plant reported its use.

26. Vacuum Filtration

In wastewater treatment plants, sludge dewatering by vacuum filtration generally uses cylindrical drum filters. These drums have a filter medium which may be cloth made of natural or synthetic fibers or a wire-mesh fabric. The drum is suspended above and dips into a vat of sludge. As the drum rotates slowly, part of its circumference is subject to an internal vacuum that draws sludge to the filter medium. Water is drawn through the porous filter cake to a discharge port, and the dewatered sludge, loosened by compressed air, is scraped from the filter mesh. Because the dewatering of sludge on vacuum filters is relatively expensive per kilogram of water removed, the liquid sludge is frequently thickened prior to processing. A vacuum filter is shown in Figure VII-30.

Application and Performance. Vacuum filters are frequently used both in municipal treatment plants and in a wide variety of industries. They are most commonly used in larger facilities, which may have a thickener to double the solids content of clarifier sludge before vacuum filtering.

The function of vacuum filtration is to reduce the water content of sludge, so that the solids content increases from about 5 percent to about 30 percent.

Advantages and Limitations. Although the initial cost and area requirement of the vacuum filtration system are higher than those of a centrifuge, the operating cost is lower, and no special provisions for sound and vibration protection need be made. The dewatered sludge from this process is in the form of a moist cake and can be conveniently handled.

Operational Factors. Reliability: Vacuum filter systems have proven reliable at many industrial and municipal treatment facilities. At present, the largest municipal installation is at the West Southwest wastewater treatment plant of Chicago, Illinois, where 96 large filters were installed in 1925, functioned approximately 25 years, and then were replaced with larger units. Original vacuum filters at Minneapolis-St. Paul, Minnesota, now have over 28 years of continuous service, and Chicago has some units with similar or greater service life.

Maintainability: Maintenance consists of the cleaning or replacement of the filter media, drainage grids, drainage piping, filter pans, and other parts of the equipment. Experience in a

number of vacuum filter plants indicates that maintenance consumes approximately 5 to 15 percent of the total time. If carbonate buildup or other problems are unusually severe, maintenance time may be as high as 20 percent. For this reason, it is desirable to maintain one or more spare units.

If intermittent operation is used, the filter equipment should be drained and washed each time it is taken out of service. An allowance for this wash time must be made in filtering schedules.

Solid Waste Aspects: Vacuum filters generate a solid cake which is usually trucked directly to landfill. All of the metals extracted from the plant wastewater are concentrated in the filter cake as hydroxides, oxides, sulfides, or other salts.

Demonstration Status. Vacuum filtration has been widely used for many years. It is a fully proven, conventional technology for sludge dewatering. Vacuum filtration is used in 18 nonferrous metals forming plants for sludge dewatering.

27. Permanganate Oxidation

Permanganate oxidation is a chemical reaction by which wastewater pollutants can be oxidized. When the reaction is carried to completion, the byproducts of the oxidation are not environmentally harmful. A large number of pollutants can be practically oxidized by permanganate, including cyanides, hydrogen sulfide, and phenol. In addition, the chemical oxygen demand (COD) and many odors in wastewaters and sludges can be significantly reduced by permanganate oxidation carried to its end point. Potassium permanganate can be added to wastewater in either dry or slurry form. The oxidation occurs optimally in the 8 to 9 pH range. As an example of the permanganate oxidation process, the following chemical equation shows the oxidation of phenol by potassium permanganate:

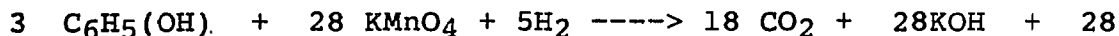

MnO_2 .

One of the byproducts of this oxidation is manganese dioxide (MnO_2), which occurs as a relatively stable hydrous colloid usually having a negative charge. These properties, in addition to its large surface area, enable manganese dioxide to act as a sorbent for metal cation, thus enhancing their removal from the wastewater.

Application and Performance. Commercial use of permanganate oxidation has been primarily for the control of phenol and waste odors. Several municipal waste treatment facilities report that initial hydrogen sulfide concentrations (causing serious odor problems) as high as 100 mg/l have been reduced to zero through the application of potassium permanganate. A variety of industries (including metal finishers and agricultural chemical manufacturers) have used permanganate oxidation to totally

destroy phenol in their wastewaters.

Advantages and Limitations. Permanganate oxidation has several advantages as a wastewater treatment technique. Handling and storage are facilitated by its non-toxic and non-corrosive nature. Performance has been proved in a number of municipal and industrial applications. The tendency of the manganese dioxide by-product to act as a coagulant aid is a distinct advantage over other types of chemical treatment.

The cost of permanganate oxidation treatment can be limiting where very large dosages are required to oxidize wastewater pollutants. In addition, care must be taken in storage to prevent exposure to intense heat, acids, or reducing agents; exposure could create a fire hazard or cause explosions. Of greatest concern is the environmental hazard which the use of manganese chemicals in treatment could cause. Care must be taken to remove the manganese from treated water before discharge.

Operational Factors. Reliability: Maintenance consists of periodic sludge removal and cleaning of pump feed lines. Frequency of maintenance is dependent on wastewater characteristics.

Solid Waste Aspects: Sludge is generated by the process where the manganese dioxide byproduct tends to act as a coagulant aid. The sludge from permanganate oxidation can be collected and handled by standard sludge treatment and processing equipment.

Demonstration Status. The oxidation of wastewater pollutants by potassium permanganate is a proven treatment process in several types of industries. It has been shown effective in treating a wide variety of pollutants in both municipal and industrial wastes. No nonferrous metals forming plants are known to use permanganate oxidation for wastewater treatment at this time.

28. Ammonia Steam Stripping

Ammonia, often used as a process reagent, dissolves in water to an extent governed by the partial pressure of the gas in contact with the liquid. The ammonia may be removed from process wastewaters by stripping with air or steam.

Air stripping takes place in a packed or lattice tower; air is blown through the packed bed or lattice, over which the ammonia-laden stream flows. Usually, the wastewater is heated prior to delivery to the tower, and air is used at ambient temperature.

The term "ammonia steam stripping" refers to the process of desorbing aqueous ammonia by contacting the liquid with a sufficient amount of ammonia-free steam. The steam is introduced countercurrent to the wastewater to maximize removal of ammonia. The operation is commonly carried out in packed bed or tray columns, and the pH is adjusted to 12 or more with lime. Simple

tray designs (such as dish and doughnut trays) are used in steam stripping because of the presence of appreciable suspended solids and the scaling produced by lime. These allow easy cleaning of the tower, at the expense of somewhat lower steam water contact efficiency, necessitating the use of more trays for the same removal efficiency.

Application and Performance. The evaporation of water and the volatilization of ammonia generally produces a drop in both temperature and pH, which ultimately limit the removal of ammonia in a single air stripping tower. However, high removals are favored by:

1. High pH values, which shift the equilibrium from ammonium toward free ammonia;
2. High temperature, which decreases the solubility of ammonia in aqueous solutions; and
3. Intimate and extended contact between the wastewater to be stripped and the stripping gas.

Of these factors, pH and temperature are generally more cost-effective to optimize than increasing contact time by an increase in contact tank volume or recirculation ratio. The temperature will, to some extent, be controlled by the climatic conditions; the pH of the wastewater can be adjusted to assure optimum stripping.

Steam stripping offers better ammonia removal (99 percent or better) than air stripping for high-ammonia wastewaters found in the magnesium forming, titanium forming and zirconium-hafnium forming subcategories of this category. The performance of an ammonia stripping column is influenced by a number of important variables that are associated with the wastewater being treated and column design. Brief discussions of these variables follow.

Wastewater pH: Ammonia in water exists in two forms, NH_3 and NH_4^+ , the distribution of which is pH-dependent. Since only the molecular form of ammonia (NH_3) can be stripped, increasing the fraction of NH_3 by increasing the pH enhances the rate of ammonia desorption.

Column Temperature: The temperature of the stripping column affects the equilibrium between gaseous and dissolved ammonia, as well as the equilibrium between the molecular and ionized forms of ammonia in water. An increase in the temperature reduces the ammonia solubility and increases the fraction of aqueous ammonia that is in the molecular form, both of which have favorable effects on the desorption rate.

Steam rate: The rate of ammonia transfer from the liquid to gas phase is directly proportional to the degree of ammonia undersaturation in the desorbing gas. Increasing the rate of

steam supply, therefore, increases undersaturation and ammonia transfer.

Column design: A properly designed stripper column achieves uniform distribution of the feed liquid across the cross-section of the column, rapid renewal of the liquid-gas interface, and extended liquid-gas contacting area and time.

Chemical analysis data were collected for raw waste (treatment influent) and treated waste (treatment effluent) from one plant in the iron and steel category. EPA collected six paired samples over a two-month period. These data are the data base for determining the effectiveness of ammonia steam stripping technology and are contained within the public record supporting this document. Ammonia treatment at this coke plant consisted of two steam stripping columns in series with steam injected countercurrently to the flow of the wastewater. A lime reactor for pH adjustment separated the two stripping columns.

An arithmetic mean of the treatment effluent data produced an ammonia long-term mean value of 32.2 mg/l. The one-day maximum, 10-day, and 30-day average concentrations attainable by ammonia steam stripping were calculated using the long-term mean of the 32.2 mg/l and the variability factors developed for the combined metals data base. This produced ammonia concentrations of 133.3, 58.6, and 52.1 mg/l ammonia for the one-day maximum, 10-day and 30-day averages, respectively.

EPA believes the performance data from the iron and steel category provide a valid measure of this technology's performance on nonferrous metals forming category wastewater.

The Agency has verified the proposed steam stripping performance values using steam stripping data collected at a zirconium-hafnium manufacturing plant, a plant in the nonferrous metals manufacturing category which has raw ammonia concentrations as high as any in the nonferrous metals forming category. Data collected by the plant represent almost two years of daily operations, and support the long-term mean used to establish treatment effectiveness.

Several comments were received regarding the application of ammonia steam stripping technology to nonferrous metals manufacturing wastewaters. These comments stated that ammonia steam stripping performance data transferred from the iron and steel category are not appropriate for the nonferrous metals manufacturing category. Many of the commenters believe plugging of the column due to precipitates will adversely affect their ability to achieve the promulgated steam stripping performance values. In developing compliance costs, the Agency designed the steam stripping module to allow for a weekly acid cleaning to reduce plugging problems (see Section VIII, p. xxx). Through Section 308 information requests, the Agency attempted to gather data at plants which stated they could not achieve the proposed limits. However, very little data were submitted to support

their claims or document column performance. Therefore, the Agency has retained the proposed performance based on the data from the iron and steel category.

Commenters on the limitations and standards for the secondary aluminum subcategory of the nonferrous metals manufacturing category contend that stripped ammonia will have to be disposed of as corrosive hazardous waste. The Agency does not agree with the commenters because ammonia has an intrinsic value. The ammonia can either be sold, given away, or reused in the manufacturing process. Steam stripping can recover significant quantities of reagent ammonia from wastewaters containing extremely high initial ammonia concentrations, which partially offsets the capital and energy costs of the technology.

Advantages and Limitations. Strippers are widely used in industry to remove a variety of materials, including hydrogen sulfide and volatile organics as well as ammonia, from aqueous streams. The basic techniques have been applied both in-process and in wastewater treatment applications and are well understood. The use of steam strippers with and without pH adjustment is standard practice for the removal of hydrogen sulfide and ammonia in the petroleum refining industry and has been studied extensively in this context. Air stripping is used to treat municipal and industrial wastewater and is recognized as an effective technique of broad applicability. Both air and steam stripping have successfully treated ammonia-laden wastewater, both within the nonferrous metals manufacturing category and for similar wastes in closely related industries.

The major drawback of air stripping is the low efficiency in cold weather and the possibility of freezing within the tower. Because lime may cause scaling problems and the types of towers used in air stripping are not easily cleaned, caustic soda is generally employed to raise the feed pH. Air stripping simply transfers the ammonia from water to air, whereas steam stripping allows for recovery and, if so desired, reuse of ammonia. The two major limitations of steam strippers are the critical column design required for proper operation and the operational problems associated with fouling of the packing material.

Operational Factors. Reliability and Maintainability: Strippers are relatively easy to operate. The most complicated part of a steam stripper is the boiler. Periodic maintenance will prevent unexpected shutdowns of the boiler.

Packing fouling interferes with the intimate contacting of liquid-gas, thus decreasing the column efficiency, and eventually leads to flooding. The stripper column is periodically taken out of service and cleaned with acid and water with air sparging. Column cutoff is predicated on a maximum allowable pressure drop across the packing of maximum "acceptable" ammonia content in the stripper bottoms. Although packing fouling may not be completely avoidable due to endothermic CaSO_4 precipitation, column runs could be prolonged by a preliminary treatment step designed to

remove suspended solids originally present in the feed and those precipitated after lime addition.

Demonstration Status. Steam stripping has proved to be an efficient, reliable process for the removal of ammonia from many types of industries wastewaters that contain high concentrations of ammonia. Industries using ammonia steam stripping technology include the fertilizer, iron and steel, petroleum refining, organic chemicals manufacturing, and nonferrous metals manufacturing industries. One nonferrous metals forming plant reported using this technology.

IN-PROCESS POLLUTION CONTROL TECHNIQUES

In general, the most cost-effective pollution reduction techniques available to any industry are those which prevent completely the entry of pollutants into process wastewater or reduce the volume of wastewater requiring treatment. These "in-process" controls can increase treatment effectiveness by reducing the volume of wastewater to treatment, resulting in more concentrated waste streams from which they can be more completely removed, or by eliminating pollutants which are not readily removed or which interfere with the treatment of other pollutants. They also frequently yield economic benefits in reduced water consumption, decreased waste treatment costs and decreased consumption or recovery of process materials.

Techniques which may be applied to reduce pollutant discharges from most nonferrous metals forming subcategories include wastewater segregation, water recycle and reuse, water use reduction, process modification, and plant maintenance and good housekeeping. Effective in-process control at most plants will entail a combination of several techniques. Frequently, the practice of one in-process control technique is required for the successful implementation of another. For example, wastewater segregation is frequently a prerequisite for the extensive practice of wastewater recycle or reuse.

Wastewater Segregation

The segregation of wastewater streams is a key element in implementing pollution control in the nonferrous metals forming category. Separation of noncontact cooling water from process wastewater prevents dilution of the process wastes and maintains the character of the non-contact stream for subsequent reuse or discharge. Similarly, the segregation of process wastewater streams differing significantly in their chemical characteristics can reduce treatment costs and increase effectiveness.

Mixing process wastewater with noncontact cooling water increases the total volume of process wastewater. This has an adverse effect on both treatment performance and cost. The increased volume of wastewater increases the size and cost of treatment

facilities. Since a given treatment technology has a specific treatment effectiveness and can only achieve certain discharge concentrations of pollutants, the total mass of pollutants which is discharged increased with dilution. Thus a plant which segregates noncontact cooling water and other nonprocess waters from process wastewater will almost always achieve a lower mass discharge of pollutants while substantially reducing treatment costs.

Nonferrous metals forming plants commonly produce multiple process and nonprocess wastewater streams. The identified nonprocess streams include wastewater streams that are reusable after minimal treatment and other streams that are not reusable. Reusable waters are most often noncontact cooling waters. This water is uncontaminated and can be recycled in a closed indirect cooling configuration as well as use as makeup for process water. Noncontact cooling water is commonly recycled for reuse.

The segregation of dilute process waste streams from those bearing high pollutant loads may allow further use of the dilute streams. Sometimes the lightly polluted stream may be recycled to the process from which they were discharged, such as annealing. Other wastewater streams may be suitable for use in another process with only minimal treatment.

Segregation of wastewater streams may allow separate treatment of the wastewater stream which often costs less. For example, wastewater streams containing high levels of suspended solids may be treated in separate inexpensive settling systems rather than a more expensive lime and settle treatment system. Often the clarified wastewater is suitable for further process use and both pollutant loads and the wastewater volume requiring further treatment are reduced.

Segregation and separate treatment of selected wastewater streams may yield an additional economic benefit to the plant by allowing increased recovery of process materials. The solids borne by wastewater from a specific process operation are primarily composed of materials used in that operation. Sludges resulting from separate settling of these streams may be reclaimed for use in the process with little or no processing or recovered for reprocessing.

Wastewater Recycle and Reuse

The recycle or reuse of process wastewater is a particularly effective technique for the reduction of both pollutant discharges and treatment costs. The term "recycle" is used to designate the return of process wastewater, usually after some treatment, to the process or processes from which it originated, while "reuse" refers to the use of wastewater from one process in another. Both recycle and reuse of process wastewater are presently practiced at nonferrous metals forming plants, although recycle is more extensively used. The most frequently recycled waste streams include wet air pollution

control wastewater discharges, casting contact cooling water, annealing and heat treatment contact cooling water and rolling emulsions. Numerous other process wastewater streams from nonferrous metals forming processes may also be recycled or reused. Both recycle and reuse are frequently possible without extensive treatment of the wastewater; process pollutants present in the waste stream are often tolerable (or occasionally even beneficial) for process use. Recycle or reuse in these instances yields cost savings by reducing the volume of wastewater requiring treatment. Where treatment is required for recycle or reuse, it is frequently considerably simpler than the treatment necessary to achieve effluent quality suitable for release to the environment. Treatment prior to recycle or reuse observed in present practice is generally restricted to simple settling or neutralization. Since these treatment practices are less costly than those used prior to discharge, economic as well as environmental benefits are usually realized. In addition to these in-process recycle and reuse practices, some plants return part or all of the treated effluent from an end-of-pipe treatment system for further process use.

Recycle can usually be implemented with minimal expense and complications because the required treatment is often minimal and the water for recycle is immediately available. As an example, hot rolling contact cooling water can be collected in the immediate area of the rolling mill cooled in a cooling tower, and recycled for use in the rolling process. A flow diagram for recycling direct chill casting water with a cooling tower is shown in Figure VII-36.

The rate of water used in wet air scrubbers is determined by the requirement for adequate contact with the air being scrubbed and not by the mass of pollutants to be removed. As a result, wastewater streams from once-through scrubbers are characteristically very dilute and high in volume. These streams can usually be recycled extensively without treatment with no deleterious effect on scrubber performance. Limited treatment such as neutralization where acid fumes are scrubbed can significantly increase the practical recycle rate.

Water used in washing process equipment and production floor areas frequently serves primarily to remove solid materials and is often treated by settling and recycled. This practice is especially prevalent in the precious metals subcategory but is observed in other subcategories as well. The extent of recycle of these waste streams may be very high, and in many cases no wastewater is discharged from the recycle loop.

Water used in surface treatment rinsing is also recirculated in some cases. This practice is ultimately limited by the concentrations of materials rinsed off the product in the rinsewater. Wastewater from contact cooling operations also may contain low concentrations of pollutants which do not interfere with the recycle of these streams. In some cases, recycle of

contact cooling water with no treatment is observed while in others, provisions for heat removal in cooling towers or closed heat exchangers is required. Where contact cooling water becomes heavily contaminated with acid, neutralization may be required to minimize corrosion.

Water used in vacuum pump seals and steam ejectors commonly becomes contaminated with process pollutants. The levels of contaminants in these waste streams are sometimes low enough to allow recycle to the process with minimal treatment. A high degree of recycle of wastewater from contact cooling streams may require provisions for neutralization or removal of heat.

The extent of recycle possible in most process water uses is ultimately limited by increasing concentrations of dissolved solids in the water. The buildup of dissolved salts generally necessitates some small discharge or "blowdown" from the process to treatment. In those cases, where the rate of addition of dissolved salts is balanced by removal of dissolved solids in water entrained in settled solids, complete recycle with no discharge can be achieved. In other instances, the contaminants which build up in the recycle loop may be compatible with another process operation, and the "blowdown" may be used in another process. An example of this is the reuse of alkaline cleaning rinsewater as make-up to an acid fume wet air pollution control recirculating system. The rinsewater provides alkaline species to neutralize the acid fumes.

Water Use Reduction

The volume of wastewater discharge from a plant or specific process operation may be reduced by simply eliminating excess flow and unnecessary water use. Often this may be accomplished with no change in the manufacturing process or equipment and without any capital expenditure. A comparison of the volumes of process water used in and discharged from equivalent process operations at different plants or on different days at the same plant indicates substantial opportunities for water use reductions. Additional reductions in process water use and discharge may be achieved by modifications to process techniques and equipment.

Many production units in nonferrous metals forming plants were observed to operate intermittently or at highly variable production rates. The practice of shutting off process water flow during periods when the unit is not operating and of adjusting flow rates during periods of low production can prevent much unnecessary water use. Water may be shut off and controlled manually or through automatically controlled valves. Manual adjustments have been found to be somewhat unreliable in practice; production personnel often fail to turn off manual valves when production units are shut down and tend to increase water flow rates to maximum levels "to insure good operation" regardless of production activity. Automatic shut-off valves may be used to turn off water flows when

production units are inactive. Automatic adjustment of flow rates according to production levels requires more sophisticated control systems incorporating production rate sensors.

Observations and flow measurements at visited nonferrous metals forming plants indicate that automatic flow controls are rarely employed. Manual control of process water use is generally observed in process rinse operations, and little or no adjustment of these flows to production level is practiced. The present situation is exemplified by a rinse operation at one plant where the daily average production normalized discharge flow rate was observed to vary from 287 to 1230 l/kkg over a three-day span. Thus, significant reductions in pollutant discharges can be achieved by the application of flow control in this category at essentially no cost. (A net savings may be realized from the reduced cost of water and sewage charges.) Additional flow reductions may be achieved by the implementation of more effective water use in some process operations.

Rinsing is a common operation in nonferrous metals forming plants and a major source of wastewater discharge at most plants. Efficient rinsing requires the removal of the greatest possible mass of material in the smallest possible volume of water. It is achieved by ensuring that the material removed is distributed uniformly through the rinse water.

Rinsing efficiency is also increased by the use of multi-stage and countercurrent cascade rinses (see figures VII-37 and VII-38). Multi-stage rinses reduce the total rinse water requirements by allowing the removal of much of the contaminant in a more concentrated rinse with only the final stage rinse diluted to the levels required for final product cleanliness. In a countercurrent cascade rinse, dilute wastewater from each rinse stage is reused in the preceding rinse stage and all of the contaminants are discharged in a single concentrated waste stream. The technical aspects of countercurrent cascade rinsing are detailed later in this section.

Equipment and area cleanup practices observed at nonferrous metals forming plants vary widely. While some plants employ completely dry cleanup techniques, many others use water with varying degrees of efficiency. The practice of "hosing down" equipment and production areas generally represents a very in-efficient use of water, especially when hoses are left running during periods when they are not used. Alternative techniques which use water more efficiently include vacuum pick-up floor wash machines and bucket and sponge or bucket and mop techniques as observed at some plants.

Additional reduction in process water and wastewater discharge may be achieved by the substitution of dry air pollution control devices such as baghouses for wet scrubbers where the emissions requiring control are amenable to these techniques.

Countercurrent Cascade Rinsing and Multistage Rinsing

Of the many schemes discussed above for reduction of water use in nonferrous metals forming plant, countercurrent cascade rinsing is most likely to result in the greatest reduction of water consumption and use.

Countercurrent cascade rinses are already employed in some plants in the nonferrous metals forming category. In most cases, however, these techniques are not combined with effective flow control, and the wastewater discharge volumes from the countercurrent cascade rinses are as large as or larger than corresponding single stage rinse flows at other plants.

Rinse water requirements and the benefits of countercurrent cascade rinsing may be influenced by the volume of drag-out solution carried into each rinse stage by the electrode or material being rinsed, by the number of rinse stages used, by the initial concentrations of impurities being removed, and by the final product cleanliness required. The influence of these factors is expressed in the rinsing equation which may be stated simply as:

$$V_r = \frac{C_o}{C_f} (1/n) \times V_D$$

V_r is the flow through each rinse stage.

C_o is the concentration of the contaminant(s) in the initial process bath

C_f is the concentration of the contaminant(s) in the final rinse to give acceptable product cleanliness

n is the number of rinse stages employed,
and

V_D is the flow of drag-out carried into each rinse stage

For a multistage rinse, the total volume of rinse wastewater is equal to n times V_r while for a countercurrent rinse, V_r is the total volume of wastewater discharge.

For a multistage rinse, the total volume of rinsewater is equal to n times V_r while for a countercurrent rinse the total volume of water equals V_r . As an example, the flow reduction achieved for pickling a nickel sheet can be estimated through the use of a two-stage countercurrent cascade rinse following the surface treatment bath. The mass of nickel in one square meter of sheet that is 6 mm (0.006 m) in thickness can be calculated using the density of nickel, 8.90 kkg/m³ (556 lbs/cu ft), as follows:

$$= (0.006 \text{ m}) \times (8.90 \text{ kkg/m}^3) = 0.053 \text{ kkg/m}^2 \text{ of sheet.}$$

Using the mean surface treatment rinsewater discharge, V_r can then be calculated as follows:

$$V_r = \frac{(0.053 \text{ kkg} \times 10,600 \text{ l})}{\text{m}^2} = \frac{561.8 \text{ kkg}}{\text{m}^2} \text{ of sheet}$$

Drag-out is solution which remains on the surface of materials being rinsed when it is removed from process baths or rinses. Without specific plant data available to determine drag-out, an estimate of rinsewater reduction to be achieved with two-stage countercurrent rinsing can be made by assuming a thickness of any process solution film as it is introduced into the rinse tank. If the film on a piece of nickel sheet is 0.015 mm (0.6 mil) thick, (equivalent to the film on a well-drained vertical surface) then the volume of process solution, VD , carried into the rinse tank on two sides of a one square meter of sheet will be:

$$VD = (0.015 \text{ mm}) \times (1 \text{ m/mm}) \times (1000 \text{ l/m}^3) \times 2$$

$$= \frac{0.030 \text{ l}}{\text{m}^2} \text{ of sheet}$$

Let $r = \frac{C_f}{C_o}$, then $r = \frac{1}{n} - \frac{V_r}{VD}$.

For single-stage rinsing, $n = 1$, therefore, $r = \frac{V_r}{VD}$

$$\text{and } r = \frac{561.8}{0.030} = 18,727$$

For a 2-stage countercurrent cascade rinse to obtain the same r , that is the same product cleanliness,

$$r = \frac{V_r}{VD} \text{ }^{1/2}, \text{ therefore } \frac{V_r}{VD} = 18,727 \text{ }^{1/2} = 136.8$$

But $VD = 0.030 \text{ l/m}^2$ of sheet; therefore, for 2-stage countercurrent cascade rinsing, V_r is:

$$V_r = 136.8 \times 0.030 = 4.10 \text{ l/m}^2 \text{ of sheet}$$

In this theoretical calculation, a flow reduction of greater than 99 percent can be achieved. The actual numbers may vary depending on efficiency of squeegees or air knives, and the rinse ratio desired.

Significant flow reductions can be achieved by the addition of only one other stage in the rinsing operation, as discussed above. The largest reductions are made by adding the first few stages. Additional rinsing stages cost additional money. The actual number of stages added depends on site-specific layout and operating conditions. With higher costs for water and waste treatment, more stages might be economical. With very low water costs, fewer stages would be economical. In considering retrofit applications, the space available for additional tanks is also important. After considering all of these points, the Agency believes that countercurrent cascade rinsing is an effective and economical means of reducing wastewater flow and consequently pollutant discharge.

If the flow from stage to stage can be effected by gravity, either by raising the latter rinse stage tanks or by varying the height of the overflow weirs, countercurrent cascade rinsing is usually quite economical. If, on the other hand, pumps and level controls must be used, then other methods, such as spray rinsing, may be more feasible.

Another factor is the need for agitation, which will reduce short circuiting of the flow. Large amounts of short circuiting can reduce the flow reduction attained by adding more stages. In cases where water is cascading in enormous quantities over a workpiece, the high flow usually provides enough agitation. As more staging is applied to reduce the amount of water, the point will be reached where the flow of the water itself is not sufficient to provide agitation. This necessitates either careful baffling of the tanks or additional mechanical agitation.

Countercurrent cascade rinsing has been widely used as a flow reduction technique in the metal finishing industry. In aluminum conversion coating lines that are subject to the coil coating limitations, countercurrent cascade rinsing is currently used in order to reduce costs of wastewater treatment systems (by allowing use of smaller systems) for direct dischargers and additionally to reduce sewer charges for indirect dischargers since those costs are based on flow.

Countercurrent cascade rinsing is currently practiced at 12 nonferrous metals forming plants.

Spray Rinsing

Spray rinsing is another method used to dilute the concentration of contaminants adhering to the surface of a workpiece. The basis of this approach is to spray water onto the surface of the workpiece as opposed to submerging it into a tank. The amount of water contacting the workpiece, and therefore the amount of water discharged, is minimized as a result. The water use and discharge rates can be further reduced through recirculation of the rinse water.

The equipment required for spray rinsing includes piping, spray nozzles, a pump, a holding tank and a collection basin. The holding tank may serve as the collection basin to collect the rinse water prior to recirculation as a method of space economization. Spray rinsing is demonstrated in plants in the nonferrous metals forming category.

Regeneration of Chemical Baths

Regeneration of chemical baths is used to remove contaminants and recover and reuse the bath chemicals, thus minimizing the chemical requirements of the bath while achieving zero discharge.

Chemical bath regeneration is applicable to recover and reuse chemicals associated with caustic surface treatment baths, sulfuric acid surface treatment baths, chromic acid surface treatment baths, and alkaline cleaning baths.

Some metal salts can be precipitated out of chemical baths by applying a temperature change or shift to the bath. Once the metal salts are precipitated out of solution, the chemical properties and utility of the bath can then be restored by adding fresh chemicals. The addition of lime may aid in precipitating dissolved metals by forming carbonates or hydroxides.

Ultrafiltration, previously discussed in this section, can be used to remove oils and particulates from alkaline cleaning baths, allowing the recovery of the water and alkali values to be reused in the make-up of fresh bath rather than treating and discharging them.

Ultrafiltration membranes allow only low molecular weight solutes and water to pass through and return to the bath; particulates and oils are held back in a concentrated phase. The concentrated material is then disposed of separately as a solid waste.

The advantages of bath regeneration are: (1) it reduces the volume of discharge of the chemical bath water; (2) the surface treatment operations are made more efficient because the bath can be kept at a relatively constant strength; (3) it results in reduced maintenance labor associated with the bath; and (4) it reduces chemical costs by recovering chemicals and increasing bath life.

Chemical bath regeneration results in lower maintenance labor because the bath life is extended. Regeneration also increases the process reliability in that it eliminates extended periods of downtime to dump the entire bath solution.

It may be necessary to allow baths normally operated at elevated temperatures to cool prior to regeneration. As an example, hot detergent baths will require cooling prior to introducing material into the ultrafiltration membrane.

Regeneration of caustic, detergent, chromic acid, and sulfuric acid baths results in the formation of precipitates. These precipitates are collected, dewatered, if necessary, and then disposed of as solid wastes. The metal sulfate precipitate resulting from sulfuric acid baths may be commercially marketable. The solid waste aspects of wastewater treatment sludges similar to regeneration sludges are discussed in detail in Section VIII.

There are commercial processes available for regenerating baths which are patented or claimed confidential. In general, these regeneration processes are based on the fundamental concepts described above.

As discussed previously in this section, ultrafiltration is well developed and commercially available for recovery of high molecular weight liquids and solid contaminants. EPA is not aware of any nonferrous metals forming plants that have applied ultrafiltration for the purpose of regenerating bath materials. There are two aluminum forming plants and one nonferrous metals forming plant using ultrafiltration to recover spent lubricant. Since alkaline cleaning baths are used to remove these lubricants from the metal surface prior to further processing, it is reasonable to assume that ultrafiltration is equally applicable for separating these same lubricants from alkaline cleaning baths used in nonferrous metals forming plants.

Regeneration may be applicable in specific applications in the nonferrous metals forming category although at present it does not appear to be applicable on a nationwide basis.

Contract Hauling

Contract hauling refers to the industry practice of contracting with a firm to collect and transport wastes for off-site disposal. This practice is particularly applicable to low-volume, high concentration waste streams. Examples of such waste streams in the nonferrous metals forming industry are pickling baths, drawing lubricants, and cold rolling lubricants.

The dcp data identified several waste solvent haulers, most of whom haul solvent in addition to their primary business of hauling waste oils. The value of waste solvents seems to be sufficient to make waste solvent hauling a viable business. Telephone interviews conducted during the development of metal finishing regulations indicate that the number of solvent haulers is increasing and that their operations are becoming more sophisticated because of the increased value of waste solvent. In addition, a number of chemical suppliers include waste hauling costs in their new solvent price. Some of the larger solvent refiners make credit arrangements with their clientele; for example, it was reported that one supplier returns 50 gallons of refined solvent for every 100 gallons hauled.

Lubricating Oil and Deoiling Solvent Recovery

The recycle of lubricating oils is a common practice in the industry. The degree of recycle is dependent upon any in-line treatment (e.g., filtration to remove metal fines and other contaminants), and the useful life of the specific oil in its application. Usually, this involves continuous recirculation of the oil, with losses in the recycle loop from evaporation, oil carried off by the metal product, and minor losses from in-line treatment. Some plants periodically replace the entire batch of oil once its required properties are depleted. In other cases, a continuous bleed or blowdown stream of oil is withdrawn from the recycle loop to maintain a constant level of oil quality. Fresh make-up oil is added to compensate for the blowdown and other losses, and in-line filtration is used between cycles.

Reuse of oil from spent emulsions used in rolling and drawing is practiced at some plants. The free oil skimmed from gravity oil and water separation, following emulsion breaking, is valuable. This free oil contains some solids and water which must be removed before the oil can be reused. The traditional treatment involves acidifying the oil in a heated cooker, using steam coils or live steam to heat the oil to a rolling boil. When the oil is sufficiently heated, the steam is shut off and the oil and water are permitted to separate. The collected floating oil layer is suitable for use as supplemental boiler fuel or for some other type of in-house reuse. Other plants choose to sell their oily wastes to oil scavengers, rather than reclaiming the oil themselves. The water phase from this operation is either sent to treatment or, if of a high enough quality, it can be recycled and used to make up fresh emulsion.

Some plants collect and recycle rolling oils via mist eliminators. In the rolling process, oils are sprayed as a fine mist on the rollers for cooling and lubricating purposes, and some of this oil becomes airborne and may be lost via exhaust fans or volatilization. With the rising price of oils, it is becoming a more common practice to prevent these losses. Another reason for using hood and mist eliminators is the improvement in the working environment.

Using organic solvents to deoil or degrease nonferrous metals is usually performed prior to sale or subsequent operations such as coating. Recycling the spent solvent can be economically attractive along with its environmental advantages. No plants are known to use distillation units to reclaim spent solvent for recycling in this category. Most plants in this category contract haul spent solvents or sell them to a reclaimer. No nonferrous metals forming plants currently discharge spent solvents as a direct discharge. There are several plants that discharge spent solvents to a POTW; however, this practice is not widespread and is subject to strict controls by the POTW for those that do discharge. The Agency is establishing a no discharge requirement for this waste stream. This is discussed more fully in Sections IX through XIII.

Dry Air Pollution Control Devices

The use of dry air pollution control devices allows the elimination of waste streams with high pollution potential, i.e., wastestreams from wet air pollution control devices. However, the choice of air pollution control equipment is complicated, and sometimes a wet system is the necessary choice. The important difference between wet and dry devices is that wet devices control gaseous pollutants as well as particulates.

Wet devices may be chosen over dry devices when any of the following factors are found: (1) the particle size is predominantly under 20 microns, (2) flammable particles or gases are to be treated and there is minimal combustion risk, (3) both vapors and particles are to be removed from the carrier medium and (4) the gases are corrosive and may damage dry air pollution control devices.

Equipment for dry control of air emissions includes cyclones, dry electrostatic precipitators, fabric filters, and afterburners. These devices remove particulate matter, the first three by entrapment and the afterburners by combustion.

Afterburner use is limited to air emissions consisting mostly of combustible particles. Characteristics of the particulate-laden gas which affect the design and use of a device are gas density, temperature, viscosity, flammability, corrosiveness, toxicity, humidity, and dew point. Particulate characteristics which affect the design and use of a device are particle size, shape, density, resistivity, concentration, and other physiochemical properties.

Scrubbers must be used in forging because of the potential fire hazard of baghouses used in this capacity. The oily mist generated in this operation is highly flammable and also tends to plug and bind fabric filters, reducing their efficiency.

Caustic surface treatment wet air pollution control is necessary due to the corrosive nature of the gases.

Proper application of a dry control device can result in particulate removal efficiencies greater than 99 percent by weight for fabric filters, electrostatic precipitators, and afterburners, and up to 95 percent for cyclones.

Common wet air pollution control devices are wet electrostatic precipitators, venturi scrubbers, and packed tower scrubbers. Collection efficiency for gases will depend on the solubility of the contaminant in the scrubbing liquid. Depending on the contaminant removed, collection efficiencies usually approach 99 percent for particles and gases.

Some nonferrous metals forming plants industry report the use of dry air pollution controls for forging.

Good Housekeeping

Good housekeeping and proper equipment maintenance are necessary factors in reducing wastewater loads to treatment systems. Control of accidental spills of oils, process chemicals, and wastewater from washdown and filter cleaning or removal can aid in maintaining the segregation of wastewater streams. Curbed areas should be used to contain or control these wastes.

Leaks in pump casings, process piping, etc., should be minimized to maintain efficient water use. One particular type of leakage which may cause a water pollution problem is the contamination of noncontact cooling water by hydraulic oils, especially if this type of water is discharged without treatment.

Good housekeeping is also important in chemical, solvent, and oil storage areas to preclude a catastrophic failure situation. Storage areas should be isolated from high fire-hazard areas and arranged so that if a fire or explosion occurs, treatment facilities will not be overwhelmed nor excessive groundwater pollution caused by large quantities of chemical-laden fire-protection water.

Bath or rinse waters that drip off the metal product while it is being transferred from one tank to another (dragout) should be collected and returned to their originating tanks. This can be done with simple drain boards.

A conscientiously applied program of water use reduction can be a very effective method of curtailing unnecessary wastewater flows. Judicious use of washdown water and avoidance of unattended running hoses can significantly reduce water use.

TABLE VII-1
pH CONTROL EFFECT ON METALS REMOVAL

	Day 1		Day 2		Day 3	
	<u>In</u>	<u>Out</u>	<u>In</u>	<u>Out</u>	<u>In</u>	<u>Out</u>
pH Range (mg/l)	2.4-3.4	8.5-8.7	1.0-3.0	5.0-6.0	2.0-5.0	6.5-8.1
TSS	39	8	16	19	16	7
Copper	312	0.22	120	5.12	107	0.66
Zinc	250	0.31	32.5	25.0	43.8	0.66

TABLE VII-2
EFFECTIVENESS OF SODIUM HYDROXIDE FOR METALS REMOVAL

	Day 1		Day 2		Day 3	
	<u>In</u>	<u>Out</u>	<u>In</u>	<u>Out</u>	<u>In</u>	<u>Out</u>
pH Range (mg/l)	2.1-2.9	9.0-9.3	2.0-2.4	8.7-9.1	2.0-2.4	8.6-9.1
Cr	0.097	0.0	0.057	0.005	0.068	0.005
Cu	0.063	0.018	0.078	0.014	0.053	0.019
Fe	9.24	0.76	15.5	0.92	9.41	0.95
Pb	1.0	0.11	1.36	0.13	1.45	0.11
Mn	0.11	0.06	0.12	0.044	0.11	0.044
Ni	0.077	0.011	0.036	0.009	0.069	0.011
Zn	.054	0.0	0.12	0.0	0.19	0.037
TSS		13		11		11

TABLE VII-3
EFFECTIVENESS OF LIME AND SODIUM HYDROXIDE FOR METALS REMOVAL

	Day 1		Day 2		Day 3	
	In	Out	In	Out	In	Out
pH Range (mg/l)	9.2-9.6	8.3-9.8	9.2	7.6-8.1	9.6	7.8-8.2
Al	37.3	0.35	38.1	0.35	29.9	0.35
Co	3.92	0.0	4.65	0.0	4.37	0.0
Cu	0.65	0.003	0.63	0.003	0.72	0.003
Fe	137	0.49	110	0.57	208	0.58
Mn	175	0.12	205	0.012	245	0.12
Ni	6.86	0.0	5.84	0.0	5.63	0.0
Se	28.6	0.0	30.2	0.0	27.4	0.0
Ti	143	0.0	125	0.0	115	0.0
Zn	18.5	0.027	16.2	0.044	17.0	0.01
TSS	4390	9	3595	13	2805	13

TABLE VII-4
THEORETICAL SOLUBILITIES OF HYDROXIDES AND SULFIDES
OF SELECTED METALS IN PURE WATER

Metal	As Hydroxide	Solubility of metal ion, mg/l	
		As Carbonate	As Sulfide
Cadmium (Cd ⁺⁺)	2.3 x 10 ⁻⁵	1.0 x 10 ⁻⁴	6.7 x 10 ⁻¹⁰
Chromium (Cr ⁺⁺⁺)	8.4 x 10 ⁻⁴		No precipitate
Cobalt (Co ⁺⁺)	2.2 x 10 ⁻¹		1.0 x 10 ⁻⁸
Copper (Cu ⁺⁺)	2.2 x 10 ⁻²		5.8 x 10 ⁻¹⁸
Iron (Fe ⁺⁺)	8.9 x 10 ⁻¹		3.4 x 10 ⁻⁵
Lead (Pb ⁺⁺)	2.1	7.0 x 10 ⁻³	3.8 x 10 ⁻⁹
Manganese (Mn ⁺⁺)	1.2		2.1 x 10 ⁻³
Mercury (Hg ⁺⁺)	3.9 x 10 ⁻⁴	3.9 x 10 ⁻²	9.0 x 10 ⁻²⁰
Nickel (Ni ⁺⁺)	6.9 x 10 ⁻³	1.9 x 10 ⁻¹	6.9 x 10 ⁻⁸
Silver (Ag ⁺)	13.3	2.1 x 10 ⁻¹	7.4 x 10 ⁻¹²
Tin (Sn ⁺⁺)	1.1 x 10 ⁻⁴		3.8 x 10 ⁻⁸
Zinc (Zn ⁺⁺)	1.1	7.0 x 10 ⁻⁴	2.3 x 10 ⁻⁷

TABLE VII-5

SAMPLING DATA FROM SULFIDE
PRECIPITATION-SEDIMENTATION SYSTEMS

Treatment	Lime, FeS, Poly-electrolyte, Settle, Filter		Lime, FeS, Poly-electrolyte, Settle, Filter		NaOH, Ferric Chloride, Na ₂ S Clarify (1 stage)	
	In	Out	In	Out	In	Out
pH (mg/l)	5.0-6.8	8-9	7.7	7.38		
Cr+6	25.6	<0.014	0.022	<0.020	11.45	<.005
Cr	32.3	<0.04	2.4	<0.1	18.35	<.005
Cu	-	-	-	-	0.029	0.003
Fe	0.52	0.10	108	0.6	-	-
Ni	-	-	0.68	<0.1	-	-
Zn	39.5	<0.07	33.9	0.01	0.060	0.009

These data were obtained from three sources:

Summary Report, Control and Treatment Technology for the Metal Finishing Industry: Sulfide Precipitation, USEPA, EPA No. 625/8/80-003, 1979.

Industrial Finishing, Vol. 35, No. 11, November, 1979.

Electroplating sampling data from plant 27045.

TABLE VII-6

SULFIDE PRECIPITATION-SEDIMENTATION PERFORMANCE

<u>Parameter</u>	<u>Treated Effluent</u> (mg/l)
Cd	0.01
Cr (T)	0.05
Cu	0.05
Pb	0.01
Hg	0.03
Ni	0.05
Ag	0.05
Zn	0.01

Table VII-6 is based on two reports:

Summary Report, Control and Treatment Technology for the Metal Finishing Industry: Sulfide Precipitation, USEPA, EPA No. 625/8/80-003, 1979.

Addendum to Development Document for Effluent Limitations Guidelines and New Source Performance Standards, Major Inorganic Products Segment of Inorganics Point Source Category, USEPA., EPA Contract No. EPA-68-01-3281 (Task 7), June, 1978.

Table VII-7

FERRITE CO-PRECIPIATION PERFORMANCE

Metal	Influent (mg/l)	Effluent (mg/l)
Mercury	7.4	0.001
Cadmium	240	0.008
Copper	10	0.010
Zinc	18	0.016
Chromium	10	<0.010
Manganese	12	0.007
Nickel	1,000	0.200
Iron	600	0.06
Bismuth	240	0.100
Lead	475	0.010

NOTE: These data are from:

Sources and Treatment of Wastewater in the Nonferrous Metals Industry, USEPA, EPA No. 600/2-80-074, 1980.

TABLE VII-8

CONCENTRATION OF TOTAL CYANIDE
(mg/l)

<u>Plant</u>	<u>Method</u>	<u>In</u>	<u>Out</u>
1057	FeSO ₄	2.57	0.024
		2.42	0.015
		3.28	0.032
33056	FeSO ₄	0.14	0.09
		0.16	0.09
12052	ZnSO ₄	0.46	0.14
		0.12	0.06
Mean			0.07

Table VII-9

MULTIMEDIA FILTER PERFORMANCE

Plant ID #	TSS Effluent Concentration, mg/l
06097	0.0, 0.0, 0.5
13924	1.8, 2.2, 5.6, 4.0, 4.0, 3.0, 2.2, 2.8
18538	3.0, 2.0, 5.6, 3.6, 2.4, 3.4
30172	1.0
36048	1.4, 7.0, 1.0
mean	2.1, 2.6, 1.5
	2.61

TABLE VII-10
PERFORMANCE OF SELECTED SETTLING SYSTEMS

PLANT ID	SETTLING DEVICE	SUSPENDED SOLIDS CONCENTRATION (mg/l)					
		Day 1		Day 2		Day 3	
		In	Out	In	Out	In	Out
01057	Lagoon	54	6	56	6	50	5
09025	Clarifier & Settling Ponds	1100	9	1900	12	1620	5
11058	Clarifier	451	17	-	-	-	-
12075	Settling Pond	284	6	242	10	502	14
19019	Settling Tank	170	1	50	1	-	-
33617	Clarifier & Lagoon	-	-	1662	16	1298	4
40063	Clarifier	4390	9	3595	12	2805	13
44062	Clarifier	182	13	118	14	174	23
46050	Settling Tank	295	10	42	10	153	8

Table VII-11

SKIMMING PERFORMANCE

<u>Plant</u>	<u>Skimmer Type</u>	<u>Oil & Grease</u>	
		<u>In</u>	<u>Out</u>
06058	API	224,669	17.9
06058	Belt	19.4	8.3

TABLE VII-12

SELECTED PARTITION COEFFICIENTS

<u>Priority Pollutant</u>	<u>Log Octanol/Water Partition Coefficient</u>
1 Acenaphthene	4.33
11 1,1,1-Trichloroethane	2.17
13 1,1-Dichloroethane	1.79
15 1,1,2,2-Tetrachloroethane	2.56
18 Bis(2-chloroethyl)ether	1.58
23 Chloroform	1.97
29 1,1-Dichloroethylene	1.48
39 Fluoranthene	5.33
44 Methylene chloride	1.25
64 Pentachlorophenol	5.01
66 Bis(2-ethylhexyl) phthalate	8.73
67 Butyl benzyl phthalate	5.80
68 Di-n-butyl phthalate	5.20
72 Benzo(a)anthracene	5.61
73 Benzo(a)pyrene	6.04
74 3,4-benzofluoranthene	6.57
75 Benzo(k)fluoranthene	6.84
76 Chrysene	5.61
77 Acenaphthylene	4.07
78 Anthracene	4.45
79 Benzo(ghi)perylene	7.23
80 Fluorene	4.18
81 Phenanthrene	4.46
82 Dibenzo(a,h)anthracene	5.97
83 Indeno(1,2,3,cd)pyrene	7.66
84 Pyrene	5.32
85 Tetrachloroethylene	2.88
86 Toluene	2.69

TABLE VII-13
TRACE ORGANIC REMOVAL BY SKIMMING
API PLUS BELT SKIMMERS
(From Plant 06058)

	<u>Inf.</u> mg/l	<u>Eff.</u> mg/l
Oil & Grease	225,000	14.6
Chloroform	0.023	0.007
Methylene Chloride	0.013	0.012
Naphthalene	2.31	0.004
N-nitrosodiphenylamine	59.0	0.182
Bis-2-ethylhexyl phthalate	11.0	0.027
Diethyl phthalate	-	-
Butylbenzyl phthalate	0.005	0.002
Di-n-octyl phthalate	0.019	0.002
Anthracene - phenanthrene	16.4	0.014
Toluene	0.02	0.012

Table VII-14
COMBINED METALS DATA EFFLUENT VALUES (mg/l)

	<u>Mean</u>	<u>One Day Max.</u>	<u>10 Day Avg. Max.</u>	<u>30 Day Avg. Max.</u>
Cd	0.079	0.34	0.15	0.13
Cr	0.084	0.44	0.18	0.12
Cu	0.58	1.90	1.00	0.73
Pb	0.12	0.42	0.20	0.16
Ni	0.74	1.92	1.27	1.00
Zn	0.33	1.46	0.61	0.45
Fe	0.41	1.20	0.61	0.50
Mn	0.16	0.68	0.29	0.21
TSS	12.0	41.0	19.5	15.5

TABLE VII-15
L&S PERFORMANCE
ADDITIONAL POLLUTANTS

<u>Pollutant</u>	<u>Average Performance (mg/l)</u>
Sb	0.7
As	0.51
Be	0.30
Hg	0.06
Se	0.30
Ag	0.10
Tl	0.50
Al	2.24
Co	0.05
F	14.5

TABLE VII-16
COMBINED METALS DATA SET - UNTREATED WASTEWATER

<u>Pollutant</u>	<u>Min. Conc (mg/l)</u>	<u>Max. Conc. (mg/l)</u>
Cd	<0.1	3.83
Cr	<0.1	116
Cu	<0.1	108
Pb	<0.1	29.2
Ni	<0.1	27.5
Zn	<0.1	337.
Fe	<0.1	263
Mn	<0.1	5.98
TSS	4.6	4390

Table VII - 17

 MAXIMUM POLLUTANT LEVEL IN UNTREATED WASTEWATER
 ADDITIONAL POLLUTANTS (MG/L)

POLLUTANT	Antimony	Arsenic & Selenium	Beryllium	Silver	Boron & Vanadium	Fluoride	Barium, Molybdenum, & Uranium	Radium-226	Tin	Titanium	Tungsten	Zirconium	Columbium & Tantalum
Antimony	8.5	-	-	-	-	-	-	-	-	-	-	-	-
Arsenic	0.024	4.2	-	-	0.008	-	-	0.008	-	-	-	-	-
Beryllium	-	-	10.24	-	<0.02	-	-	-	-	-	-	-	-
Cadmium	0.83	<0.1	-	<0.1	0.043	<0.1	<0.25	-	1.88	<0.25	<0.03	<0.25	9.2
Chromium	-	0.18	8.60	0.23	14.0	22.8	0.4	0.035	79.2	0.4	0.07	<0.3	13
Copper	0.41	33.2	1.24	110.5	2.4	2.2	4.7	0.02	107.0	4.7	0.2	0.5	120
Lead	76.0	6.5	0.35	11.4	2.70	5.35	9.2	0.065	0.168	9.2	0.2	22	160
Mercury	-	-	-	-	-	-	-	-	-	-	-	-	-
Nickel	-	-	-	100	34.0	0.69	1.4	0.06	47.7	1.4	0.9	<0.25	170
Selenium	-	0.9	-	-	-	-	-	-	-	-	-	-	-
Silver	-	-	-	4.7	0.001	-	-	-	-	-	-	-	2.2
Zinc	0.53	3.62	0.12	1512	0.3	<0.1	0.6	0.17	197	0.6	1.0	<0.25	0.5
Barium	-	-	-	-	-	-	2.6	-	-	-	-	-	-
Boron	-	-	-	-	17.0	-	1.6	-	-	-	-	-	-
Cobalt	-	-	-	-	-	-	2.2	-	-	-	-	-	-
Columbium	-	-	-	-	-	-	-	-	-	-	-	-	98
Fluoride	-	-	-	-	1050	760	12	-	9.25	12	-	-	-
Iron	-	-	646	-	62.0	-	-	-	38.3	-	-	-	-
Molybdenum	-	-	-	-	0.5	-	9.2	0.07	-	-	-	-	-
Radium-226*	-	-	-	-	-	-	-	1090	-	-	-	-	-
Tantalum	-	-	-	-	-	-	-	-	-	-	-	-	90
Tin	-	-	-	-	1.1	-	-	-	4.39	-	-	-	-
Titanium	-	-	-	-	-	-	-	-	-	24	12	-	170
Tungsten	-	-	-	-	-	-	-	-	-	-	2.4	-	37
Uranium	-	-	-	-	-	-	230	10.53	-	230	-	-	-
Vanadium	-	-	-	-	-	37	6.0	-	-	-	-	-	-
Zirconium	-	-	-	-	-	-	-	-	-	-	-	170	6.7
Oil & Grease	-	16.9	-	16	34	2.8	220	-	33	220	<1	860	72
Total Suspended Solids	134	352	796	587.8	690	5.6	420	1639	3500	420	<1	42	450

* Value in picocuries per liter.

(-) Indicates pollutant not analyzed

TABLE VII-18

PRECIPITATION-SETTLING-FILTRATION (LS&F) PERFORMANCE
Plant A

Parameters	No. Pts.	Range mg/l	Mean + std. dev.	Mean + 2 std. dev.
<u>For 1979-Treated Wastewater</u>				
Cr	47	0.015 - 0.13	0.045 +0.029	0.10
Cu	12	0.01 - 0.03	0.019 +0.006	0.03
Ni	47	0.08 - 0.64	0.22 +0.13	0.48
Zn	47	0.08 - 0.53	0.17 +0.09	0.35
Fe				
<u>For 1978-Treated Wastewater</u>				
Cr	47	0.01 - 0.07	0.06 +0.10	0.26
Cu	28	0.005 - 0.055	0.016 +0.010	0.04
Ni	47	0.10 - 0.92	0.20 +0.14	0.48
Zn	47	0.08 - 2.35	0.23 +0.34	0.91
Fe	21	0.26 - 1.1	0.49 +0.18	0.85
<u>Raw Waste</u>				
Cr	5	32.0 - 72.0		
Cu	5	0.08 - 0.45		
Ni	5	1.65 - 20.0		
Zn	5	33.2 - 32.0		
Fe	5	10.0 - 95.0		

TABLE VII-19

PRECIPITATION-SETTLING-FILTRATION (LS&F) PERFORMANCE
Plant B

<u>Parameters</u>	<u>No Pts.</u>	<u>Range mg/l</u>		<u>Mean +</u> <u>std. dev.</u>		<u>Mean + 2</u> <u>std. dev.</u>
<u>For 1979-Treated Wastewater</u>						
Cr	175	0.0	- 0.40	0.068	+0.075	0.22
Cu	176	0.0	- 0.22	0.024	+0.021	0.07
Ni	175	0.01	- 1.49	0.219	+0.234	0.69
Zn	175	0.01	- 0.66	0.054	+0.064	0.18
Fe	174	0.01	- 2.40	0.303	+0.398	1.10
TSS	2	1.00	- 1.00			
<u>For 1978-Treated Wastewater</u>						
Cr	144	0.0	- 0.70	0.059	+0.088	0.24
Cu	143	0.0	- 0.23	0.017	+0.020	0.06
Ni	143	0.0	- 1.03	0.147	+0.142	0.43
Zn	131	0.0	- 0.24	0.037	+0.034	0.11
Fe	144	0.0	- 1.76	0.200	+0.223	0.47
<u>Total 1974-1979-Treated Wastewater</u>						
Cr	1288	0.0	- 0.56	0.038	+0.055	0.15
Cu	1290	0.0	- 0.23	0.011	+0.016	0.04
Ni	1287	0.0	- 1.88	0.184	+0.211	0.60
Zn	1273	0.0	- 0.66	0.035	+0.045	0.13
Fe	1287	0.0	- 3.15	0.402	+0.509	1.42
<u>Raw Waste</u>						
Cr	3	2.80	- 9.15	5.90		
Cu	3	0.09	- 0.27	0.17		
Ni	3	1.61	- 4.89	3.33		
Zn	2	2.35	- 3.39			
Fe	3	3.13	-35.9	22.4		
TSS	2	177	-466.			

TABLE VII-20

PRECIPITATION-SETTLING-FILTRATION (LS&F) PERFORMANCE
Plant C

<u>For Treated Wastewater</u>		<u>Range mg/l</u>	<u>Mean +</u>		<u>Mean + 2</u>
<u>Parameters</u>	<u>No Pts.</u>		<u>std. dev.</u>	<u>std. dev.</u>	
<u>For Treated Wastewater</u>					
Cd	103	0.010 - 0.500	0.049	+0.049	0.147
Zn	103	0.039 - 0.899	0.290	+0.131	0.552
TSS	103	0.100 - 5.00	1.244	+1.043	3.33
pH	103	7.1 - 7.9	9.2*		
<u>For Untreated Wastewater</u>					
Cd	103	0.039 - 2.319	0.542	+0.381	1.304
Zn	103	0.949 - 29.8	11.009	+6.933	24.956
Fe	3	0.107 - 0.46	0.255		
TSS	103	0.80 - 19.6	5.616	+2.896	11.408
pH	103	6.8 - 8.2	7.6*		

* pH value is median of 103 values.

Table VII-21

SUMMARY OF TREATMENT EFFECTIVENESS (mg/l)

Pollutant Parameter	Mean	L&S Technology System			Mean	LS&F Technology System			Sulfide Precipitation Filtration			
		One-Day Maximum	10-Day Average	30-Day Average		One-Day Maximum	10-Day Average	30-Day Average	Mean	One-Day Maximum	10-Day Average	30-Day Average
114 Sb	0.70	2.87	1.28	1.14	0.47	1.93	0.86	0.76				
115 As	0.51	2.09	0.93	0.83	0.34	1.39	0.62	0.55				
117 Be	0.30	1.23	0.55	0.49	0.20	0.82	0.37	0.32				
118 Cd	0.079	0.34	0.15	0.13	0.049	0.20	0.08	0.08	0.01	0.04	0.018	0.016
119 Cr	0.084	0.44	0.18	0.12	0.07	0.37	0.15	0.10	0.08	0.21	0.091	0.081
120 Cu	0.58	1.90	1.00	0.73	0.39	1.28	0.61	0.49	0.05	0.21	0.091	0.081
121 CN	0.07	0.29	0.12	0.11	0.047	0.20	0.08	0.08				
122 Pb	0.12	0.42	0.20	0.16	0.08	0.28	0.13	0.11	0.01	0.04	0.018	0.016
123 Hg	0.06	0.25	0.10	0.10	0.036	0.15	0.06	0.06	0.03	0.13	0.0555	0.049
124 Ni	0.74	1.92	1.27	1.00	0.22	0.55	0.37	0.29	0.05	0.21	0.091	0.081
125 Se	0.30	1.23	0.55	0.49	0.20	0.82	0.37	0.33				
126 Ag	0.10	0.41	0.17	0.16	0.07	0.29	0.12	0.10	0.05	0.21	0.091	0.081
127 Tl	0.50	2.05	0.91	0.81	0.34	1.40	0.61	0.55				
128 Zn	0.33	1.46	0.61	0.45	0.23	1.02	0.42	0.31	0.01	0.04	0.018	0.016
Al	2.24	6.43	3.20	2.52	1.49	6.11	2.71	2.41				
Co	0.05	0.21	0.09	0.08	0.034	0.14	0.07	0.06				
F	14.5	59.5	26.4	23.5		59.5	26.4	23.5				
Fe	0.41	1.20	0.61	0.50	0.28	1.20	0.61	0.50				
Mn	0.16	0.68	0.29	0.21	0.14	0.30	0.23	0.19				
P	4.08	16.7	6.83	6.60	2.72	11.2	4.6	4.4				
O&G TSS	12.0	20.0 41.0	12.0 19.5	10.0 15.5	2.6	10.0 15.0	10.0 12.0	10.0 10.0				

1414

Table VII-22.

SUMMARY OF TREATMENT EFFECTIVENESS FOR SELECTED NONCONVENTIONAL METAL POLLUTANTS (mg/l)

Pollutant Parameter	Mean	L&S Technology System			Mean	LS&F Technology System		
		One-Day Maximum	10-Day Average	30-Day Average		One-Day Maximum	10-Day Average	30-Day Average
NH ₃	32.2	133.3	58.6	52.1	32.2	133.3	58.6	52.1
Cb	**	0.12*	**	**	**	0.12*	**	**
Au	**	0.1	**	**	**	0.1	**	**
Hf	7.28	28.8	13.9	NC	4.81	19.7	9.01	NC
Mg	**	0.1*	**	**	**	0.1*	**	**
Mo	1.83	6.61	3.42	NC	1.23	5.03	2.23	NC
Pt	**	0.1	**	**	**	0.1	**	**
Ta	**	0.45*	**	**	**	0.45*	**	**
Ti	0.19	0.94	0.41	NC	0.13	0.53	0.23	NC
W	1.29	6.96	2.78	NC	0.85	3.48	1.55	NC
U	4.00	6.50	4.73	NC	2.67	4.29	3.12	NC
V	**	0.1*	**	**	**	0.1*	**	**
Zr	7.28	28.8	13.9	NC	4.81	19.7	9.01	NC

**None established.

*Limits of detection.

NC - Not calculated.

TABLE VII-23
TREATABILITY RATING OF PRIORITY POLLUTANTS
UTILIZING CARBON ADSORPTION

<u>Priority Pollutant</u>	<u>*Removal Rating</u>	<u>Priority Pollutant</u>	<u>*Removal Rating</u>
1. acenaphthene	H	49. trichlorofluoromethane	M
2. acrolein	L	50. dichlorodifluoromethane	L
3. acrylonitrile	L	51. chlorodibromomethane	M
4. benzene	M	52. hexachlorobutadiene	H
5. benzidine	H	53. hexachlorocyclopentadiene	H
6. carbon tetrachloride (tetrachloromethane)	M	54. isophorone	H
7. chlorobenzene	H	55. naphthalene	H
8. 1,2,3-trichlorobenzene	H	56. nitrobenzene	H
9. hexachlorobenzene	H	57. 2-nitrophenol	H
10. 1,2-dichloroethane	M	58. 4-nitrophenol	H
11. 1,1,1-trichloroethane	M	59. 2,4-dinitrophenol	H
12. hexachloroethane	H	60. 4,6-dinitro-o-cresol	H
13. 1,1-dichloroethane	M	61. N-nitrosodimethylamine	M
14. 1,1,2-trichloroethane	M	62. N-nitrosodiphenylamine	H
15. 1,1,2,2-tetrachloroethane	H	63. N-nitrosodi-n-propylamine	M
16. chloroethane	L	64. pentachlorophenol	H
17. bis(chloromethyl) ether	-	65. phenol	M
18. bis(2-chloroethyl) ether	M	66. bis(2-ethylhexyl)phthalate	H
19. 2-chloroethylvinyl ether (mixed)	L	67. butyl benzyl phthalate	H
20. 2-chloronaphthalene	H	68. di-n-butyl phthalate	H
21. 2,4,6-trichlorophenol	H	69. di-n-octyl phthalate	H
22. parachlorometa cresol	H	70. diethyl phthalate	H
23. chloroform (trichloromethane)	L	71. dimethyl phthalate	H
24. 2-chlorophenol	H	72. 1,2-benzanthracene (benzo(a)anthracene)	H
25. 1,2-dichlorobenzene	H	73. benzo(a)pyrene (3,4-benzo- pyrene)	H
26. 1,3-dichlorobenzene	H	74. 3,4-benzofluoranthene (benzo(b)fluoranthene)	H
27. 1,4-dichlorobenzene	H	75. 1,1,12-benzofluoranthene (benzo(k)fluoranthene)	H
28. 3,3'-dichlorobenzidine	H	76. chrysene	H
29. 1,1-dichloroethylene	L	77. acenaphthylene	H
30. 1,2-trans-dichloroethylene	L	78. anthracene	H
31. 2,4-dichlorophenol	H	79. 1,12-benzoperylene (benzo (ghi)-perylene)	H
32. 1,2-dichloropropane	M	80. fluorene	H
33. 1,2-dichloropropylene (1,3-dichloropropene)	M	81. phenanthrene	H
34. 2,4-dimethylphenol	H	82. 1,2,3,6-dibenzanthracene (dibenzo(a,h)anthracene)	H
35. 2,4-dinitrotoluene	H	83. indeno (1,2,3-cd) pyrene (2,3-o-phenylene pyrene)	H
36. 2,6-dinitrotoluene	H	84. pyrene	-
37. 1,2-diphenylhydrazine	H	85. tetrachloroethylene	M
38. ethylbenzene	M	86. toluene	M
39. fluoranthene	H	87. trichloroethylene	L
40. 4-chlorophenyl phenyl ether	H	88. vinyl chloride (chloroethylene)	L
41. 4-bromophenyl phenyl ether	H	106. PCB-1242 (Aroclor 1242)	H
42. bis(2-chloroisopropyl)ether	M	107. PCB-1254 (Aroclor 1254)	H
43. bis(2-chloroethoxy)methane	M	108. PCB-1221 (Aroclor 1221)	H
44. methylene chloride (dichloromethane)	L	109. PCB-1332 (Aroclor 1232)	H
45. methyl chloride (chloromethane)	L	110. PCB-1248 (Aroclor 1248)	H
46. methyl bromide (bromomethane)	L	111. PCB-1260 (Aroclor 1260)	H
47. bromoform (tribromomethane)	H	112. PCB-1016 (Aroclor 1016)	H
48. dichlorobromomethane	M		

*Note Explanation of Removal Ratings

Category H (high removal)

adsorbs at levels ≥ 100 mg/g carbon at $C_f = 10$ mg/l

adsorbs at levels ≥ 100 mg/g carbon at $C_f < 1.0$ mg/l

Category M (moderate removal)

adsorbs at levels ≥ 100 mg/g carbon at $C_f = 10$ mg/l

adsorbs at levels ≤ 100 mg/g carbon at $C_f < 1.0$ mg/l

Category L (low removal)

adsorbs at levels < 100 mg/g carbon at $C_f = 10$ mg/l

adsorbs at levels < 10 mg/g carbon at $C_f < 1.0$ mg/l

C_f = final concentrations of priority pollutant at equilibrium

Table VII - 24

CLASSES OF ORGANIC COMPOUNDS ADSORBED ON CARBON

<u>Organic Chemical Class</u>	<u>Examples of Chemical Class</u>
Aromatic Hydrocarbons	benzene, toluene, xylene
Polynuclear Aromatics	naphthalene, anthracene biphenyls
Chlorinated Aromatics	chlorobenzene, polychlorinated biphenyls, aldrin, endrin, toxaphene, DDT
Phenolics	phenol, cresol, resorcinol and polyphenyls
Chlorinated Phenolics	trichlorophenol, pentachloro- phenol
High Molecular Weight Aliphatic and Branch Chain Hydrocarbons	gasoline, kerosine
Chlorinated Aliphatic Hydrocarbons	carbon tetrachloride, perchloroethylene
High Molecular Weight Aliphatic Acids and Aromatic Acids	tar acids, benzoic acid
High Molecular Weight Aliphatic Amines and Aromatic Amines	aniline, toluene diamine
High Molecular Weight Ketones, Esters, Ethers and Alcohols	hydroquinone, polyethylene glycol
Surfactants	alkyl benzene sulfonates
Soluble Organic Dyes	melkylene blue, Indigo carmine

High Molecular Weight includes compounds in the broad range of from 4 to 20 carbon atoms.

Table VII-25
 ACTIVATED CARBON PERFORMANCE (MERCURY)

Plant	<u>Mercury levels - mg/l</u>	
	<u>In</u>	<u>Out</u>
A	28.0	0.9
B	0.36	0.015
C	0.008	0.0005

Table VII-26
ION EXCHANGE PERFORMANCE

Parameter	Plant A		Plant B	
	Prior To Purifi- cation	After Purifi- cation	Prior To Purifi- cation	After Purifi- cation
All Values mg/l				
Al	5.6	0.20	-	-
Cd	5.7	0.00	-	-
Cr+3	3.1	0.01	-	-
Cr+6	7.1	0.01	-	-
Cu	4.5	0.09	43.0	0.10
CN	9.8	0.04	3.40	0.09
Au	-	-	2.30	0.10
Fe	7.4	0.01	-	-
Pb	-	-	1.70	0.01
Mn	4.4	0.00	-	-
Ni	6.2	0.00	1.60	0.01
Ag	1.5	0.00	9.10	0.01
SO4	-	-	210.00	2.00
Sn	1.7	0.00	1.10	0.10
Zn	14.8	0.40	-	-

Table VII-27

MEMBRANE FILTRATION SYSTEM EFFLUENT

Specific Metal	Manufacturers Guarantee	Plant 19066		Plant 31022		Predicted Performance
		<u>In</u>	<u>Out</u>	<u>In</u>	<u>Out</u>	
Al	0.5	---	---	---	---	
Cr, (+6)	0.02	0.46	0.01	5.25	<0.005	
Cr (T)	0.03	4.13	0.018	98.4	0.057	0.05
Cu	0.1	18.8	0.043	8.00	0.222	0.20
Fe	0.1	288	0.3	21.1	0.263	0.30
Pb	0.05	0.652	0.01	0.288	0.01	0.05
CN	0.02	<0.005	<0.005	<0.005	<0.005	0.02
Ni	0.1	9.56	0.017	194	0.352	0.40
Zn	0.1	2.09	0.046	5.00	0.051	0.10
TSS	---	632	0.1	13.0	8.0	1.0

Table VII-28

PEAT ADSORPTION PERFORMANCE

<u>Pollutant</u> (mg/l)	<u>In</u>	<u>Out</u>
Cr+6	35,000	0.04
Cu	250	0.24
CN	36.0	0.7
Pb	20.0	0.025
Hg	1.0	0.02
Ni	2.5	0.07
Ag	1.0	0.05
Sb	2.5	0.9
Zn	1.5	0.25

Table VII-29

ULTRAFILTRATION PERFORMANCE

<u>Parameter</u>	<u>Feed (mg/l)</u>	<u>Permeate (mg/l)</u>
Oil (freon extractable)	1230	4
COD	8920	148
TSS	1380	13
Total Solids	2900	296

TABLE VII-30

CHEMICAL EMULSION BREAKING EFFICIENCIES

<u>Parameter</u>	<u>Concentration (mg/l)</u>		<u>Reference</u>
	<u>Influent</u>	<u>Effluent</u>	
O&G	6,060	98	Sampling data*
TSS	2,612	46	
O&G	13,000	277	Sampling data+
	18,400	---	
	21,300	189	
TSS	540	121	
	680	59	
	1,060	140	
O&G	2,300	52	Sampling data**
	12,500	27	
	13,800	18	
TSS	1,650	187	
	2,200	153	
	3,470	63	
O&G	7,200	80	Katnick and Pavilcius, 197

*Oil and grease and total suspended solids were taken as grab samples before and after batch emulsion breaking treatment which used alum and polymer on emulsified rolling oil wastewater.

+Oil and grease (grab) and total suspended solids (grab) samples were taken on three consecutive days from emulsified rolling oil wastewater. A commercial demulsifier was used in this batch treatment.

**Oil and grease (grab) and total suspended solids (composite) samples were taken on three consecutive days from emulsified rolling oil wastewater. A commercial demulsifier (polymer) was used in this batch treatment.

++This result is from a full-scale batch chemical treatment system for emulsified oils from a steel rolling mill.

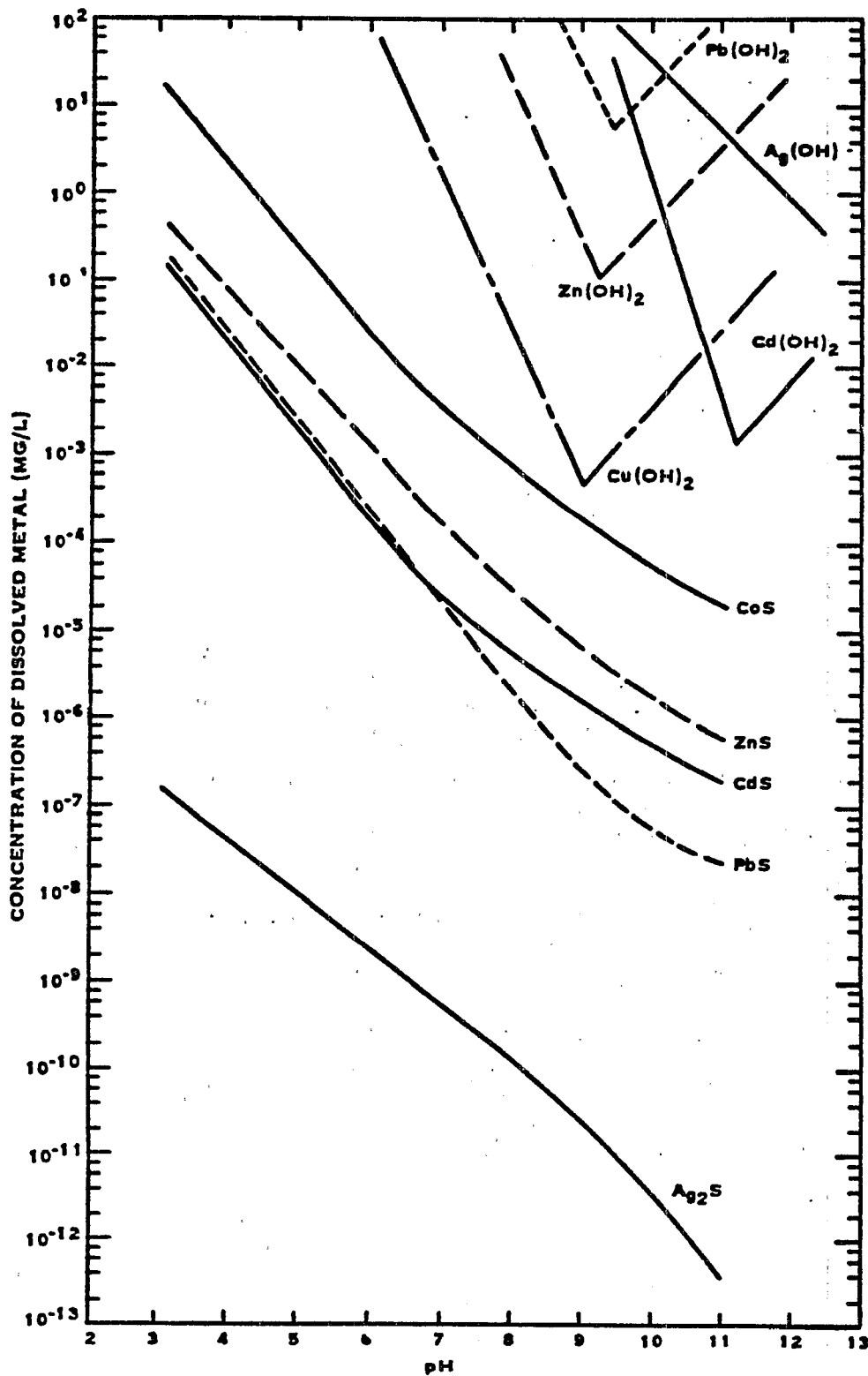

FIGURE VII-1. COMPARATIVE SOLUBILITIES OF METAL HYDROXIDES AND SULFIDE AS A FUNCTION OF pH

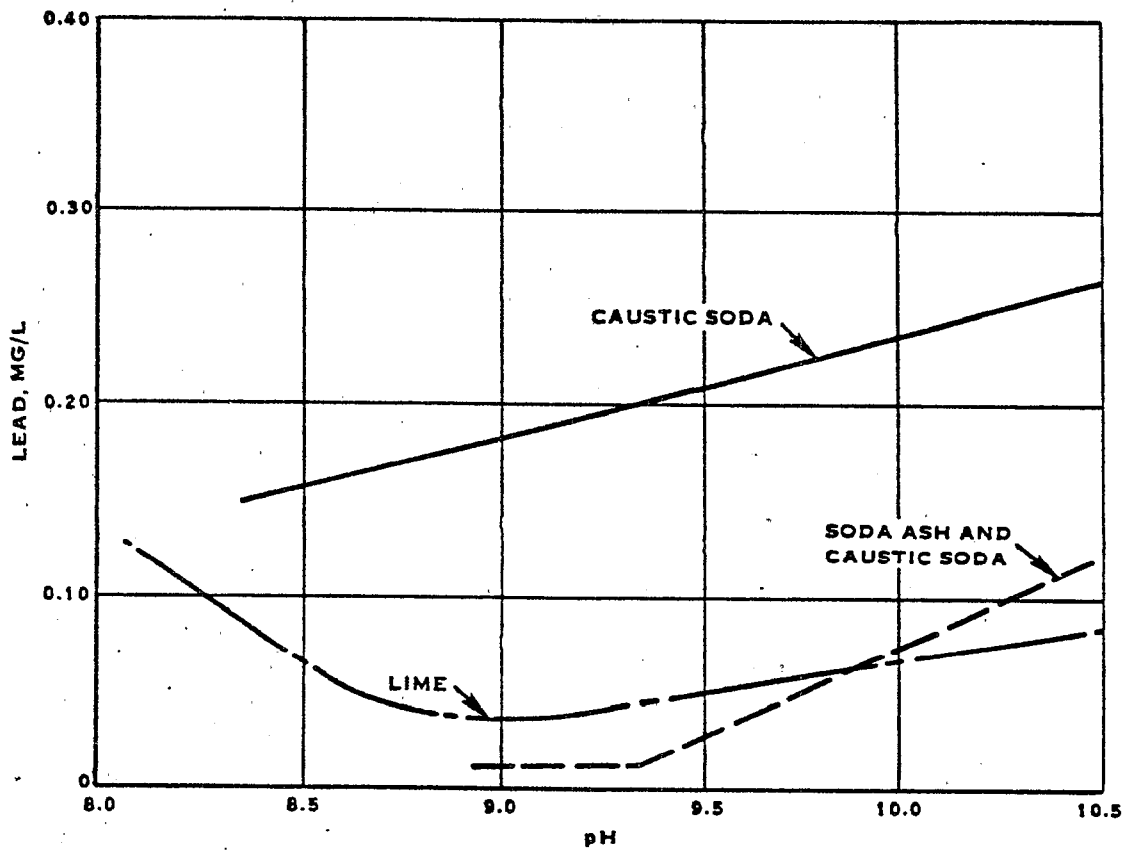

FIGURE VII-2. LEAD SOLUBILITY IN THREE ALKALIES

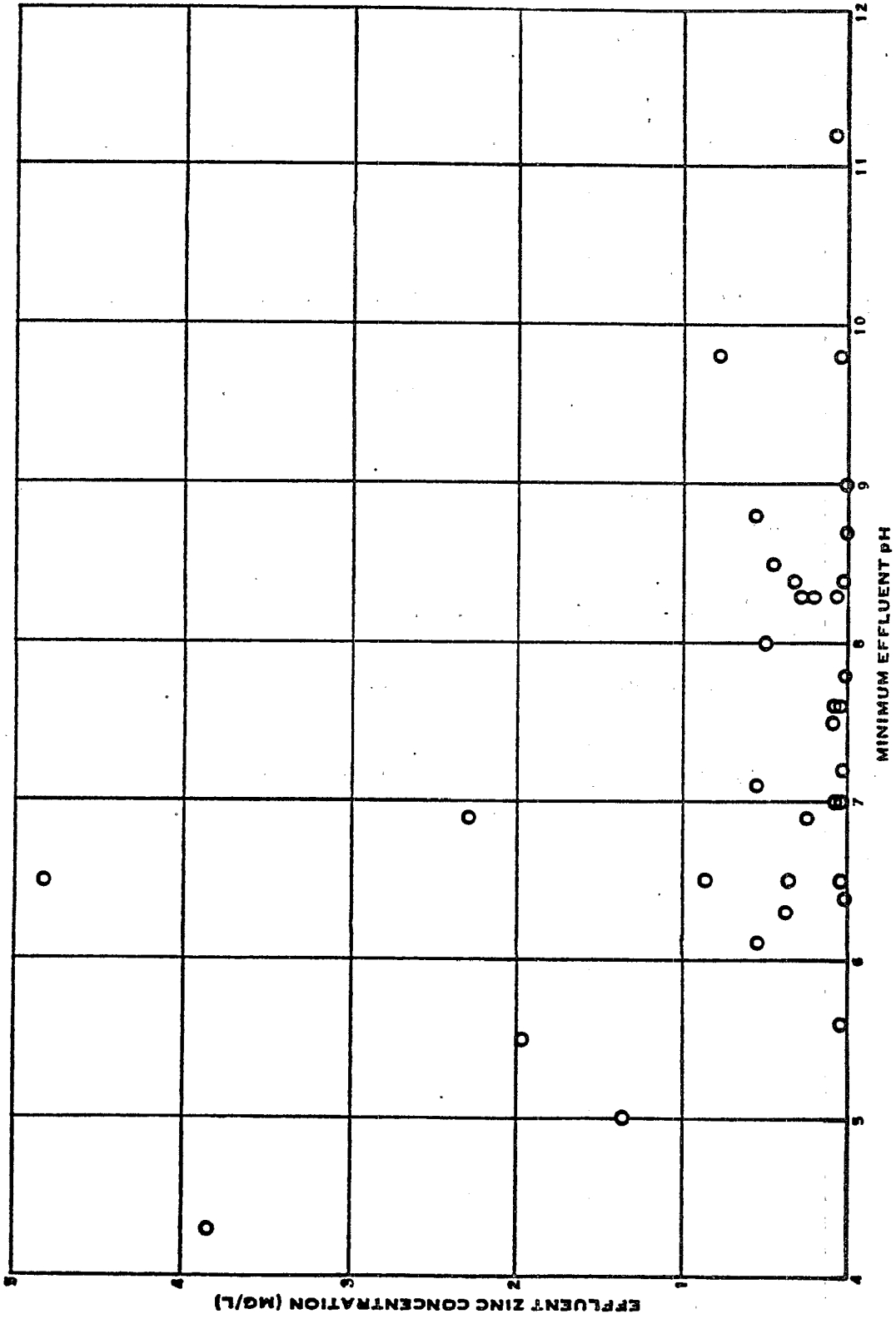
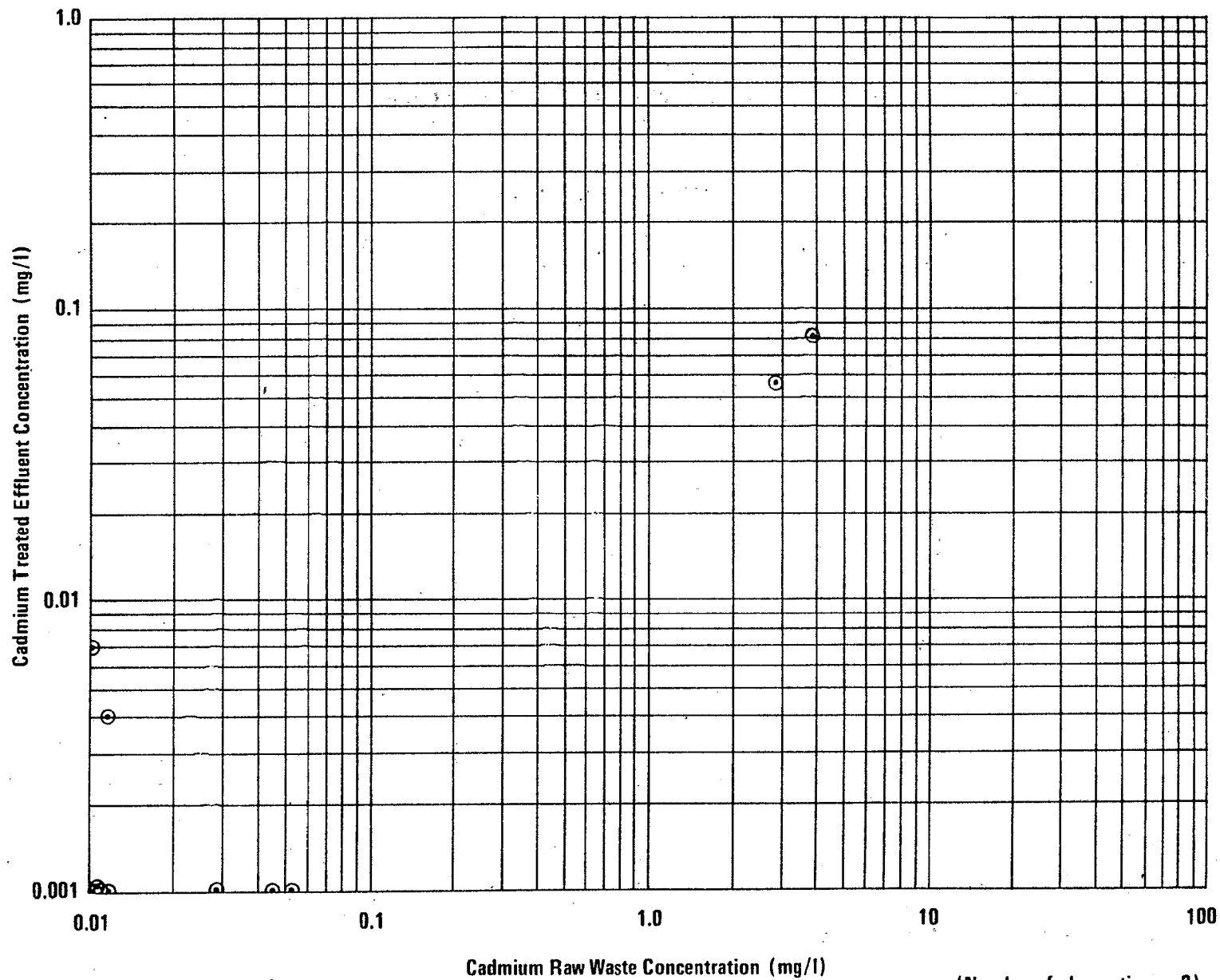

FIGURE VII-3. EFFLUENT ZINC CONCENTRATION VS. MINIMUM EFFLUENT pH



Data points with a raw waste concentration less than 0.1 mg/l were not included in treatment effectiveness calculations.

(Number of observations = 2)

FIGURE VII-4
HYDROXIDE PRECIPITATION SEDIMENTATION EFFECTIVENESS
CADMIUM

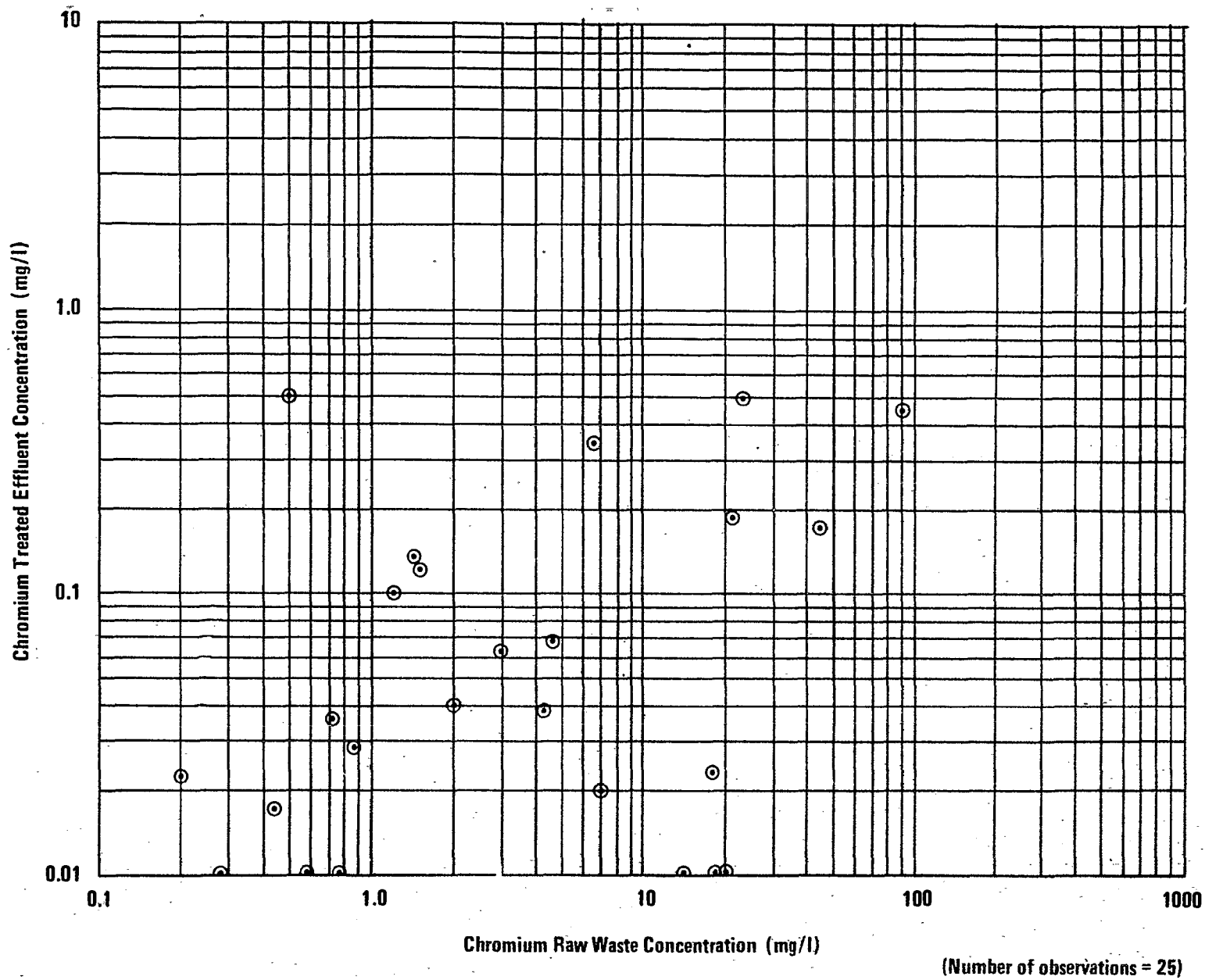

FIGURE VII-5
HYDROXIDE PRECIPITATION SEDIMENTATION EFFECTIVENESS
CHROMIUM

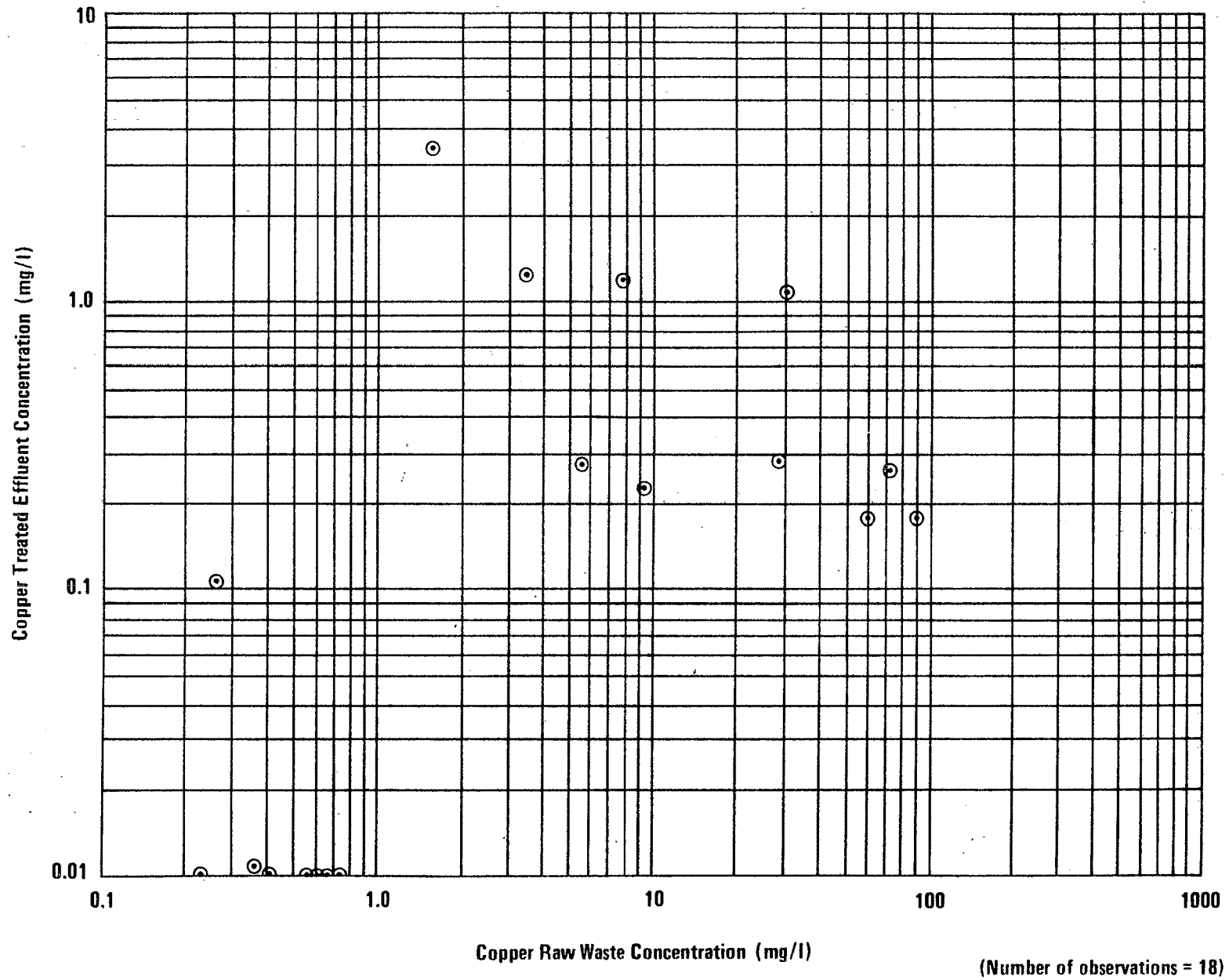

FIGURE VII-6
HYDROXIDE PRECIPITATION SEDIMENTATION EFFECTIVENESS
COPPER

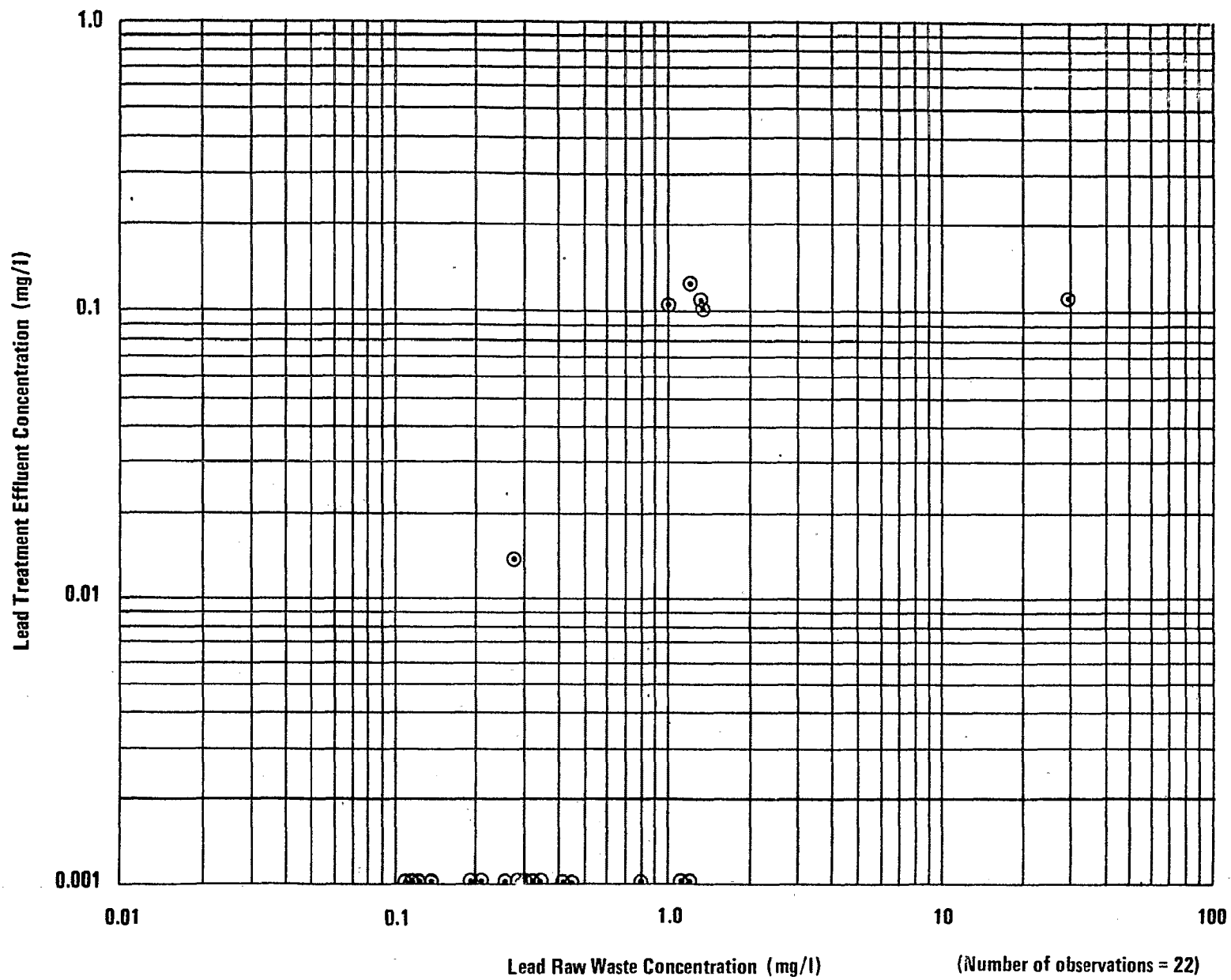
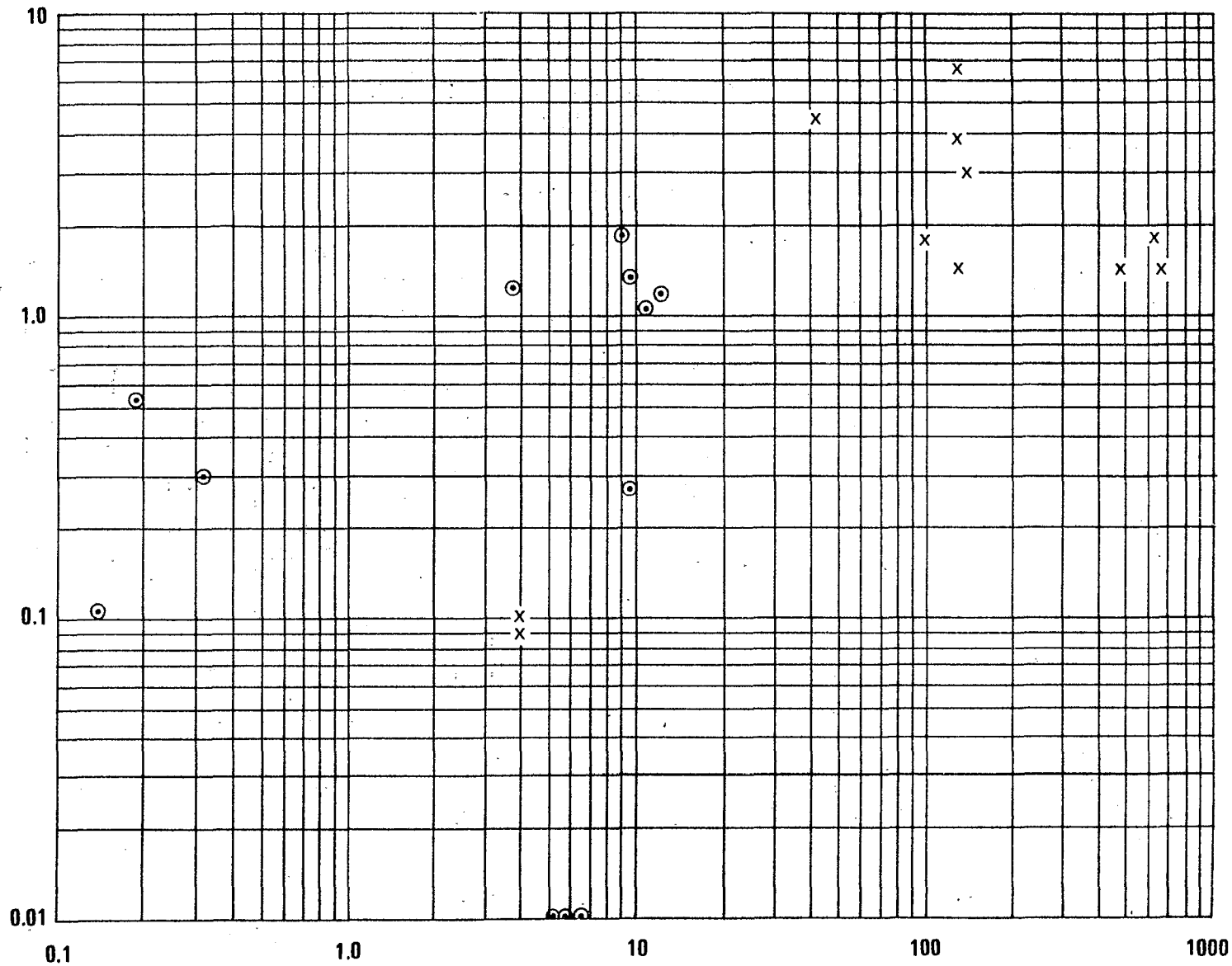

FIGURE VII-7
HYDROXIDE PRECIPITATION SEDIMENTATION EFFECTIVENESS
LEAD

x Aluminum Treated Effluent Concentration (mg/l)
 o Nickel Treated Effluent Concentration (mg/l)



o Nickel Raw Waste Concentration (mg/l)

(Number of observations = 12)

x Aluminum Raw Waste Concentration (mg/l)

(Number of observations = 11)

FIGURE VII-8
 HYDROXIDE PRECIPITATION SEDIMENTATION EFFECTIVENESS
 NICKEL AND ALUMINUM

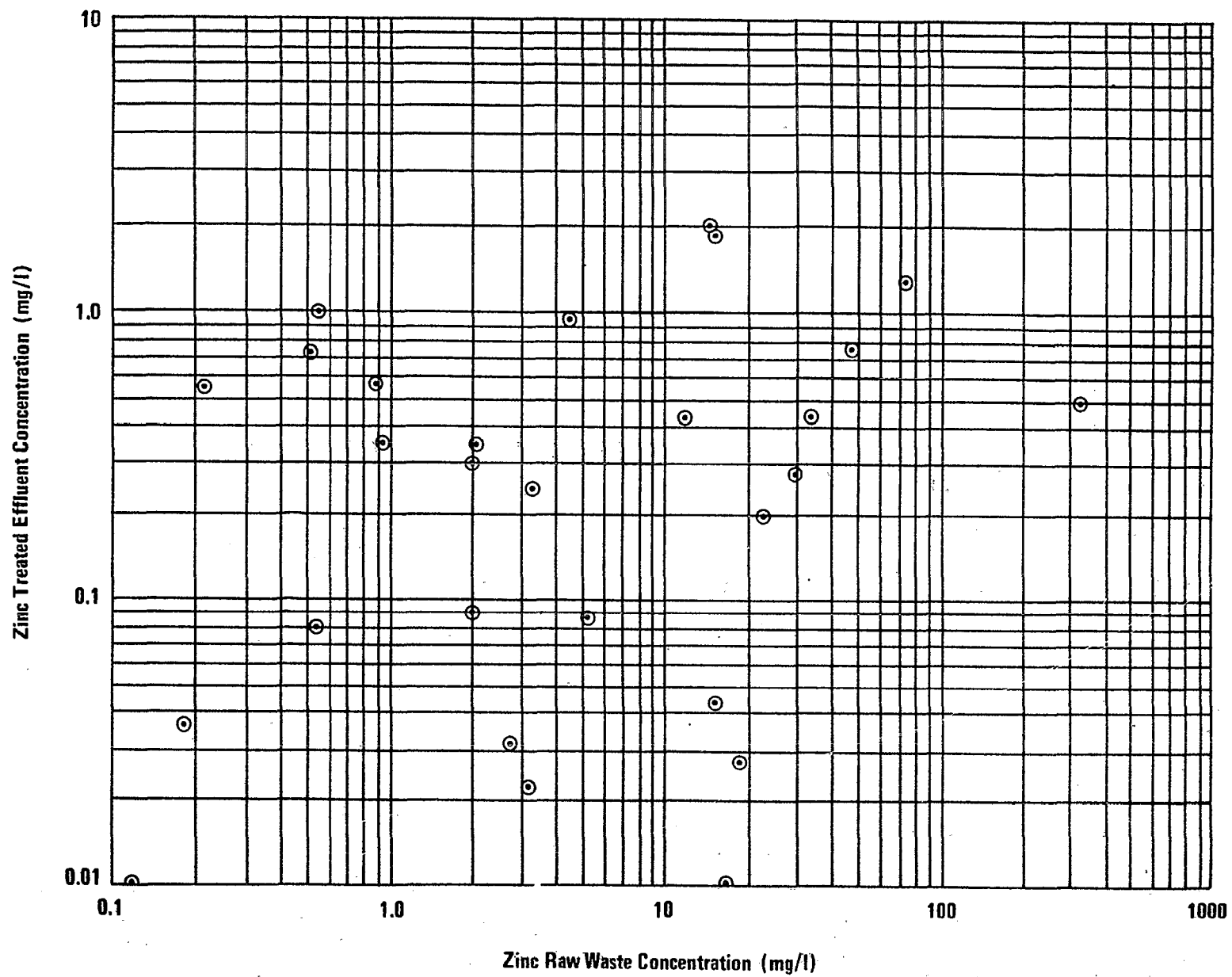

(Number of observations = 28)

FIGURE VII-9
HYDROXIDE PRECIPITATION SEDIMENTATION EFFECTIVENESS
ZINC

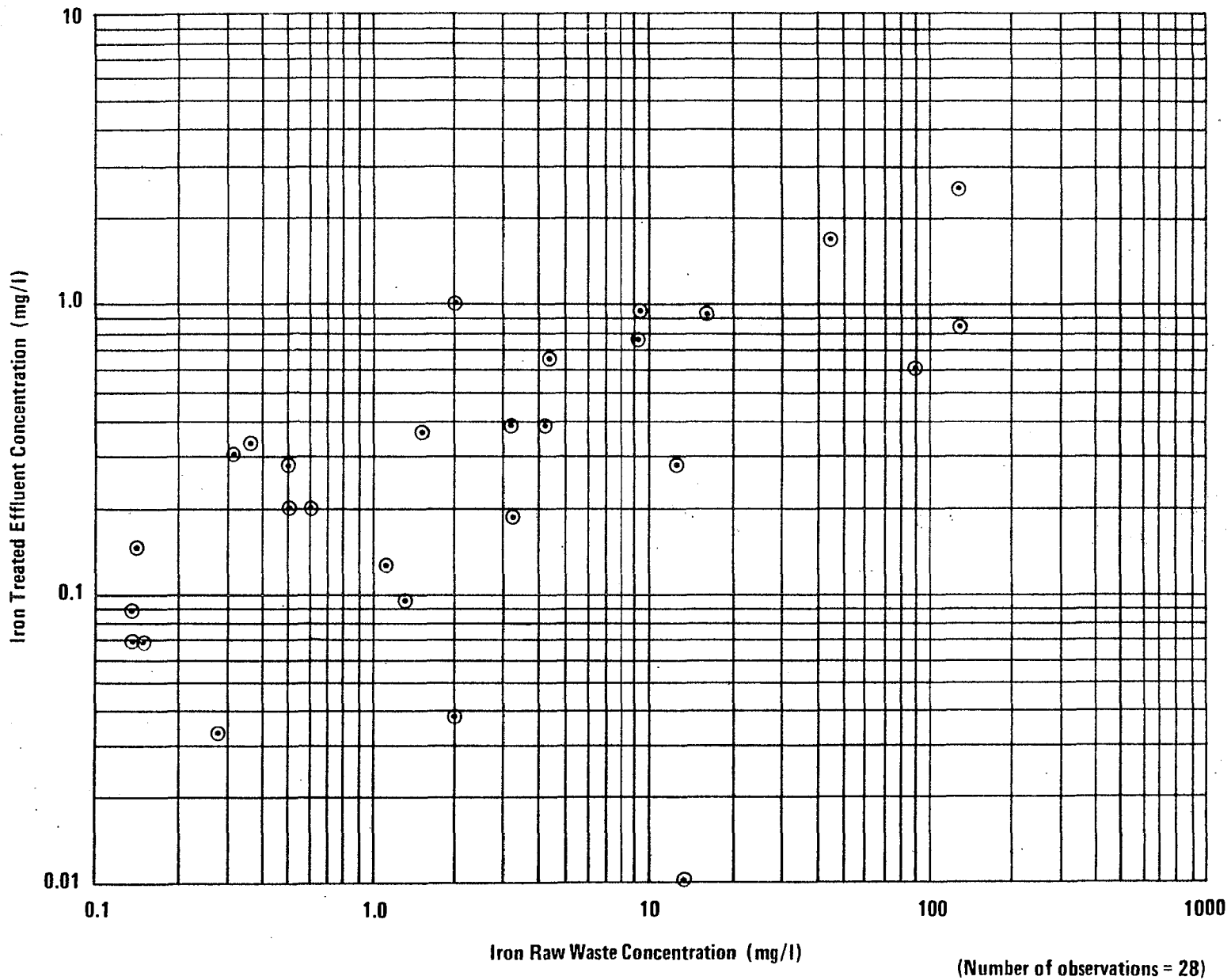
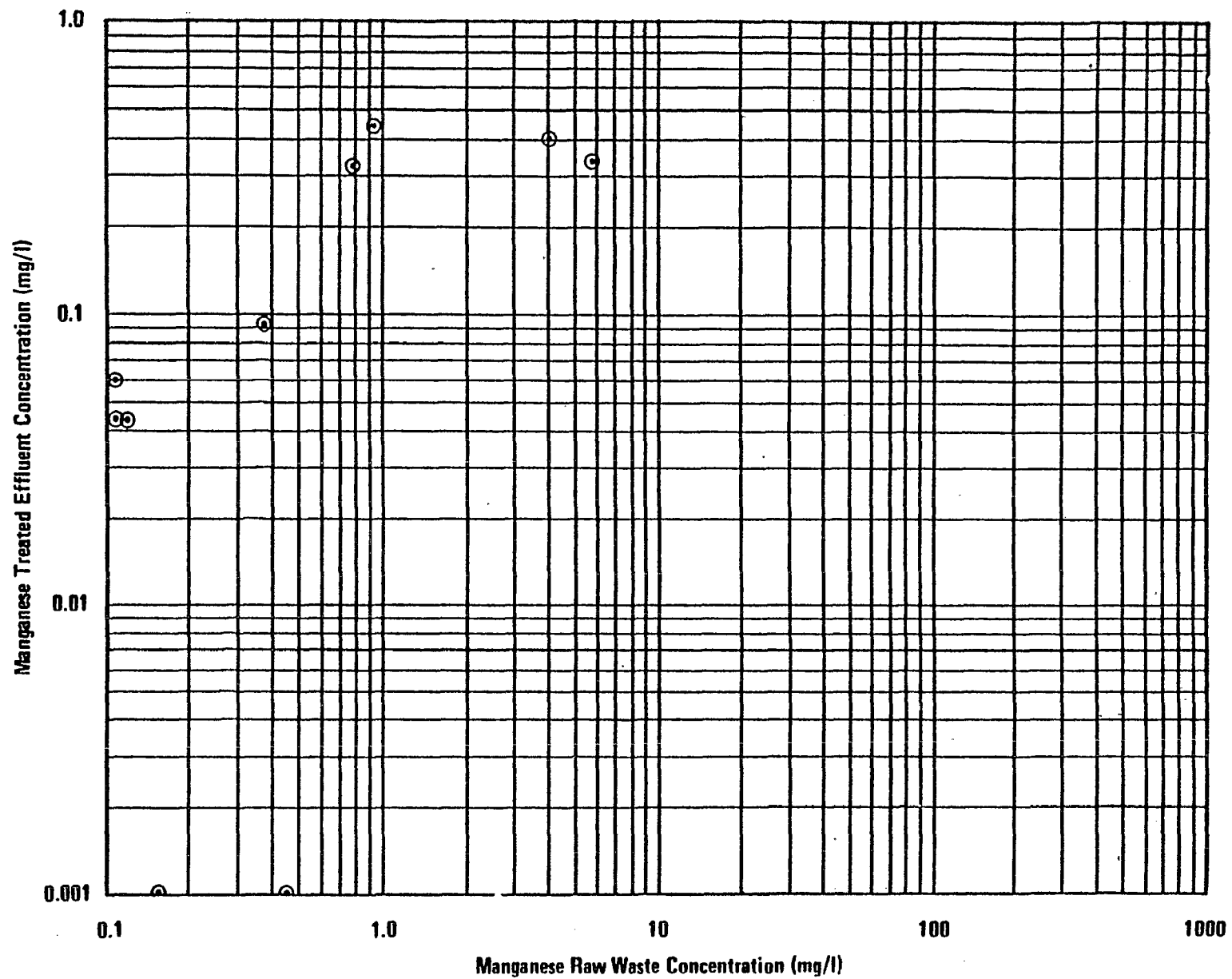

FIGURE VII-10
HYDROXIDE PRECIPITATION SEDIMENTATION EFFECTIVENESS
IRON



(Number of observations = 10)

FIGURE VII-11
HYDROXIDE PRECIPITATION SEDIMENTATION EFFECTIVENESS
MANGANESE

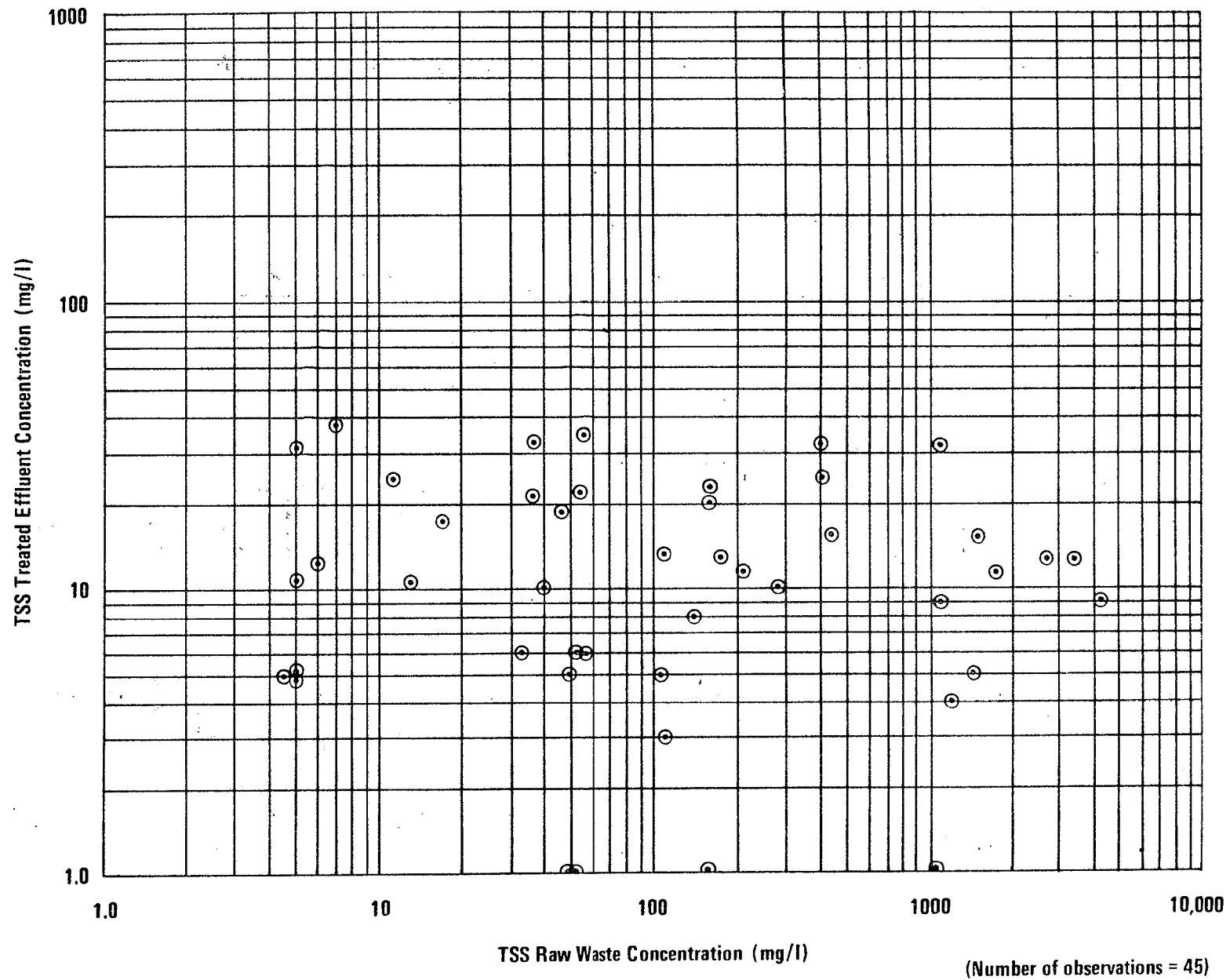

FIGURE VII-12
HYDROXIDE PRECIPITATION SEDIMENTATION EFFECTIVENESS
TSS

1434

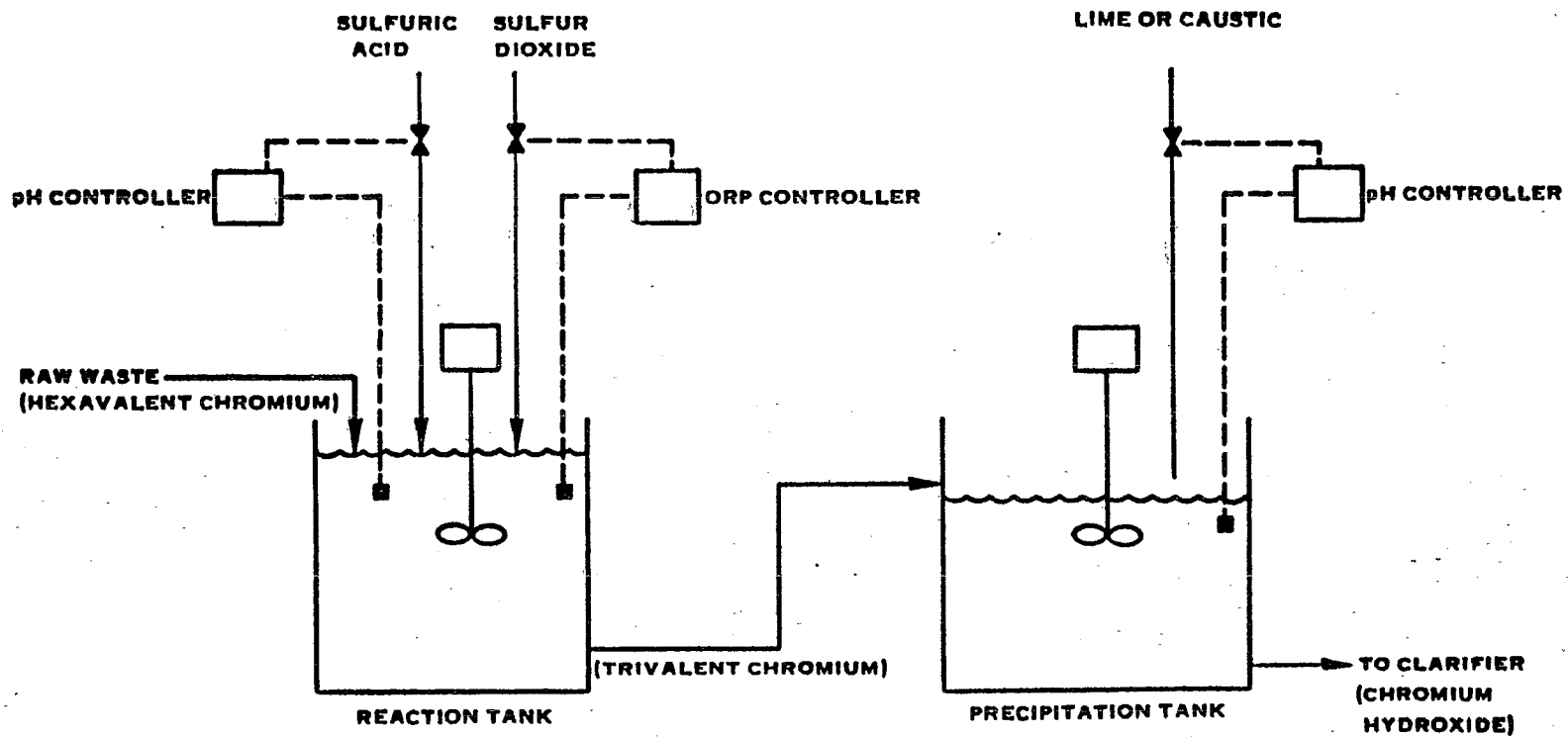

FIGURE VII-13. HEXAVALENT CHROMIUM REDUCTION WITH SULFUR DIOXIDE

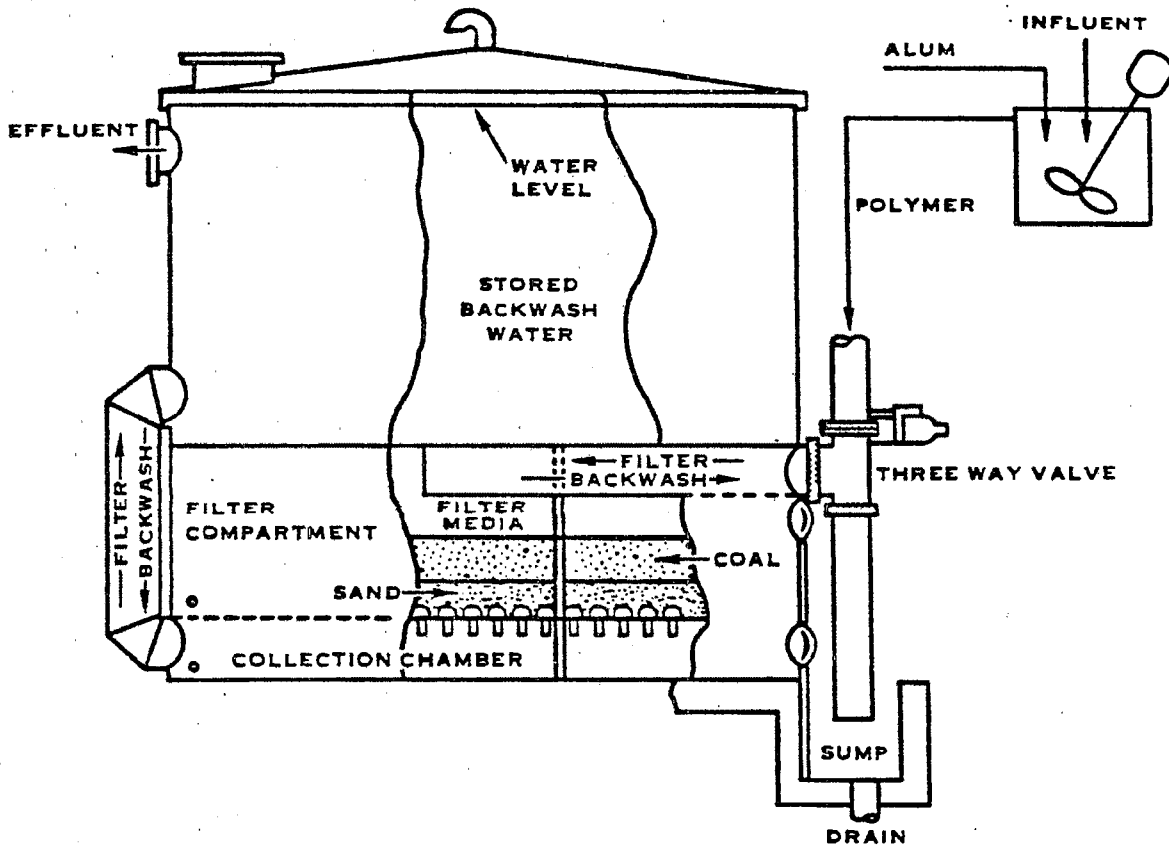

FIGURE VII-14. GRANULAR BED FILTRATION

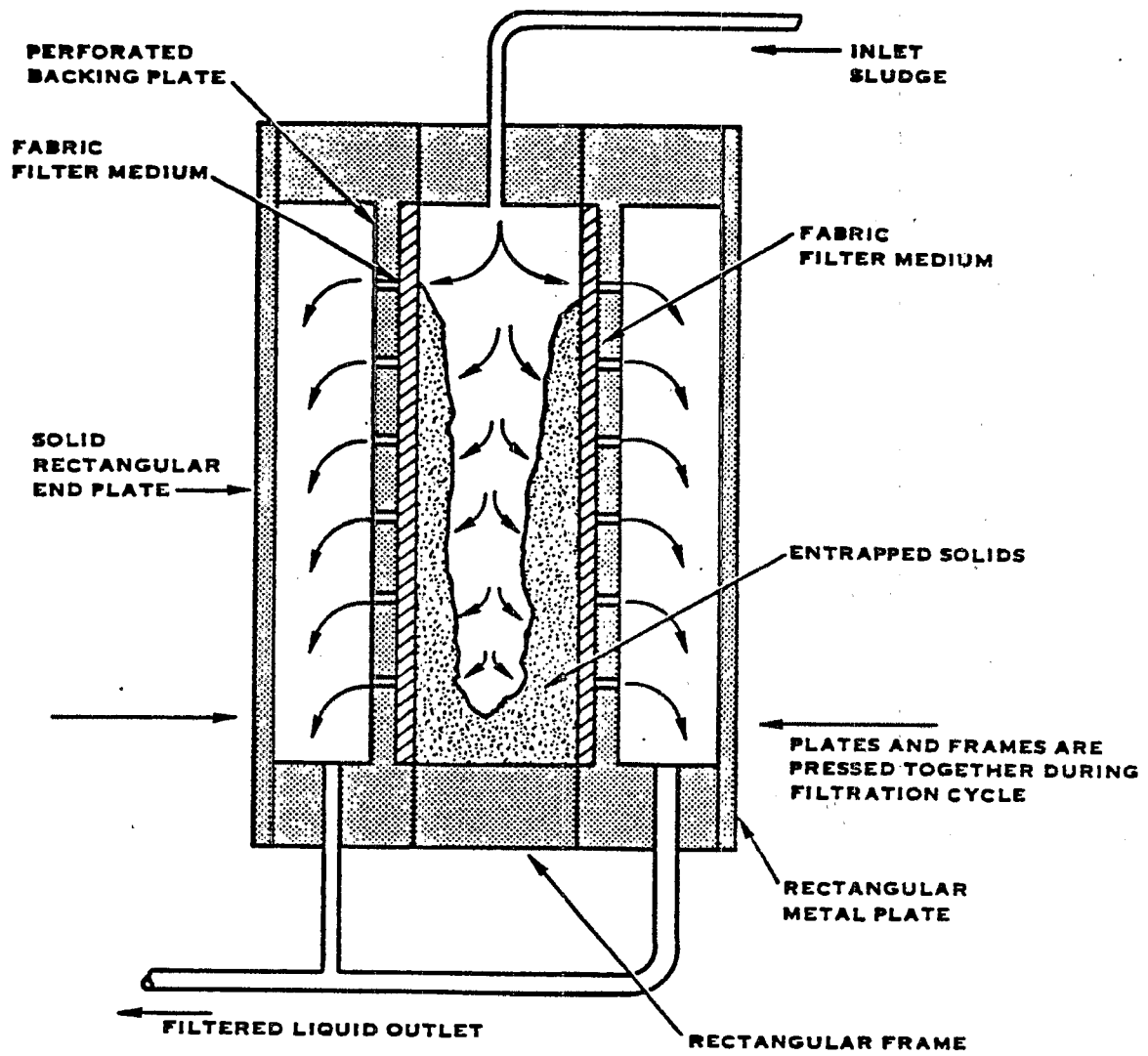
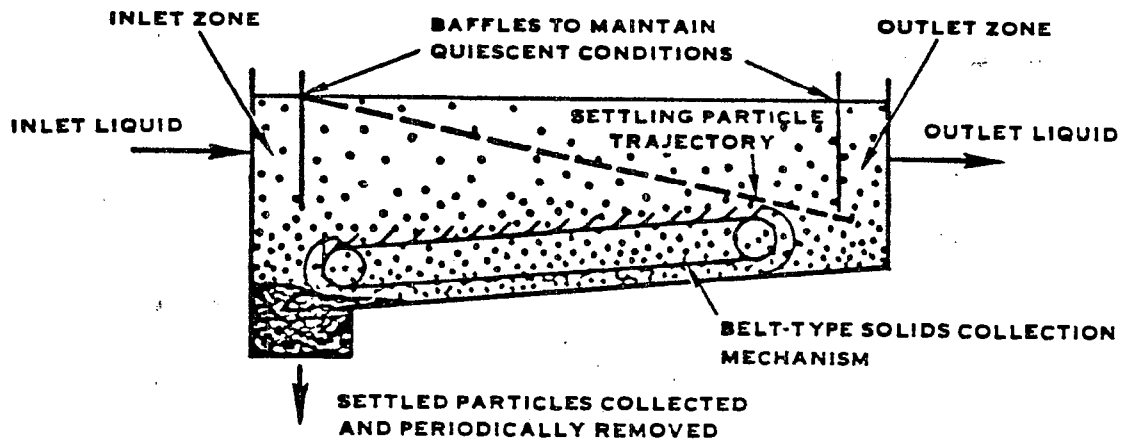

FIGURE VII-15. PRESSURE FILTRATION

SEDIMENTATION BASIN



CIRCULAR CLARIFIER

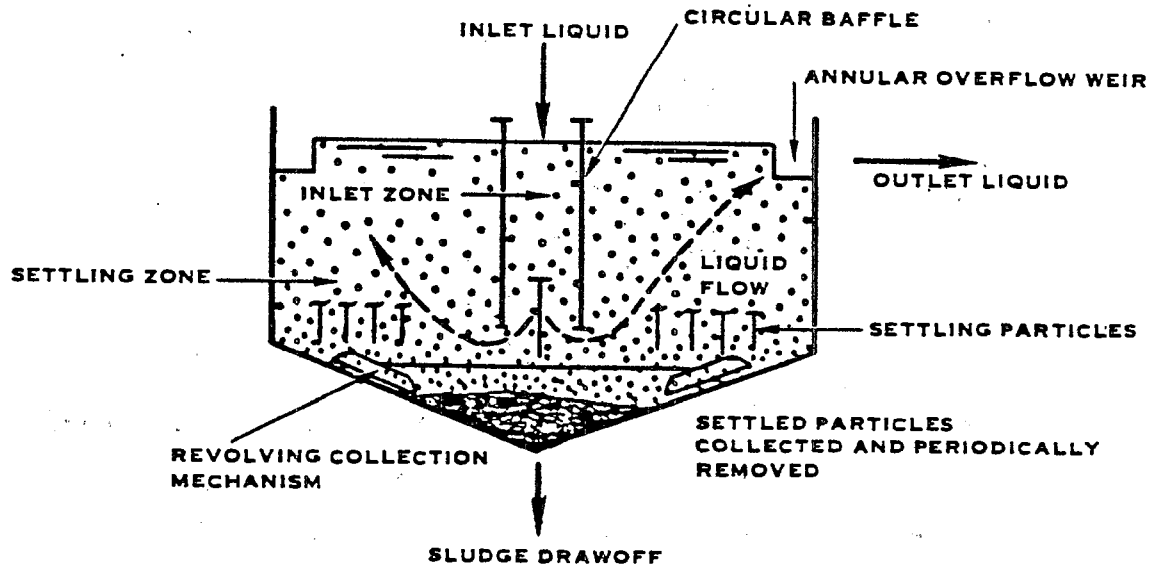

FIGURE VII-16. REPRESENTATIVE TYPES OF SEDIMENTATION

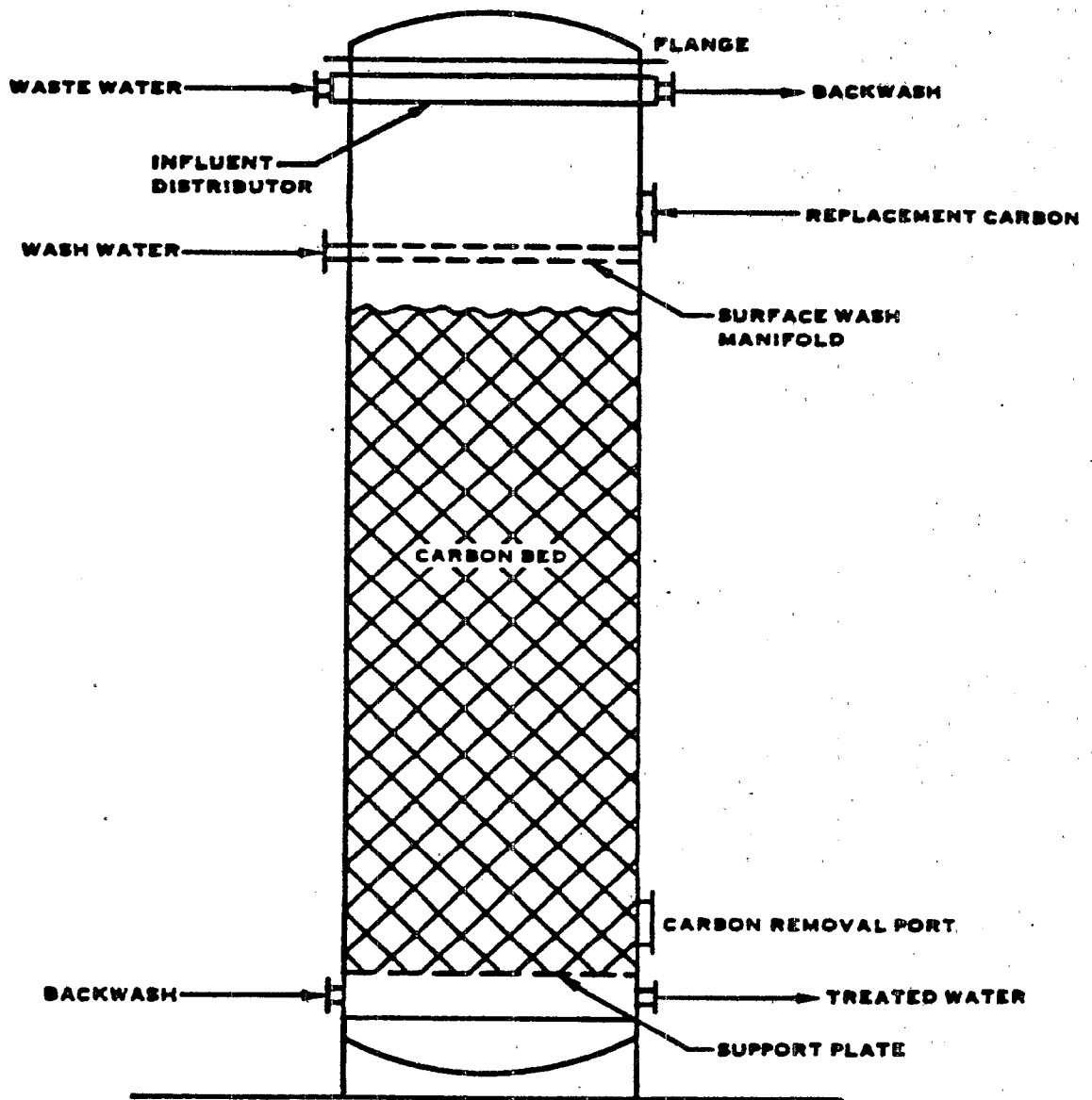

FIGURE VII-17. ACTIVATED CARBON ADSORPTION COLUMN

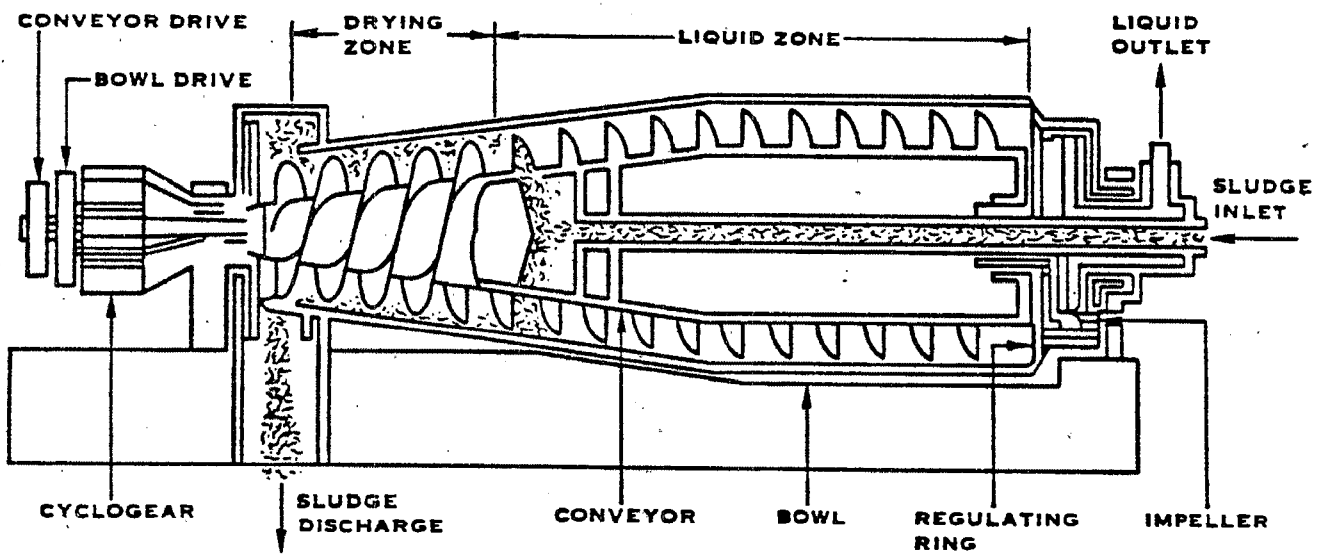

FIGURE VII-18. CENTRIFUGATION

1440

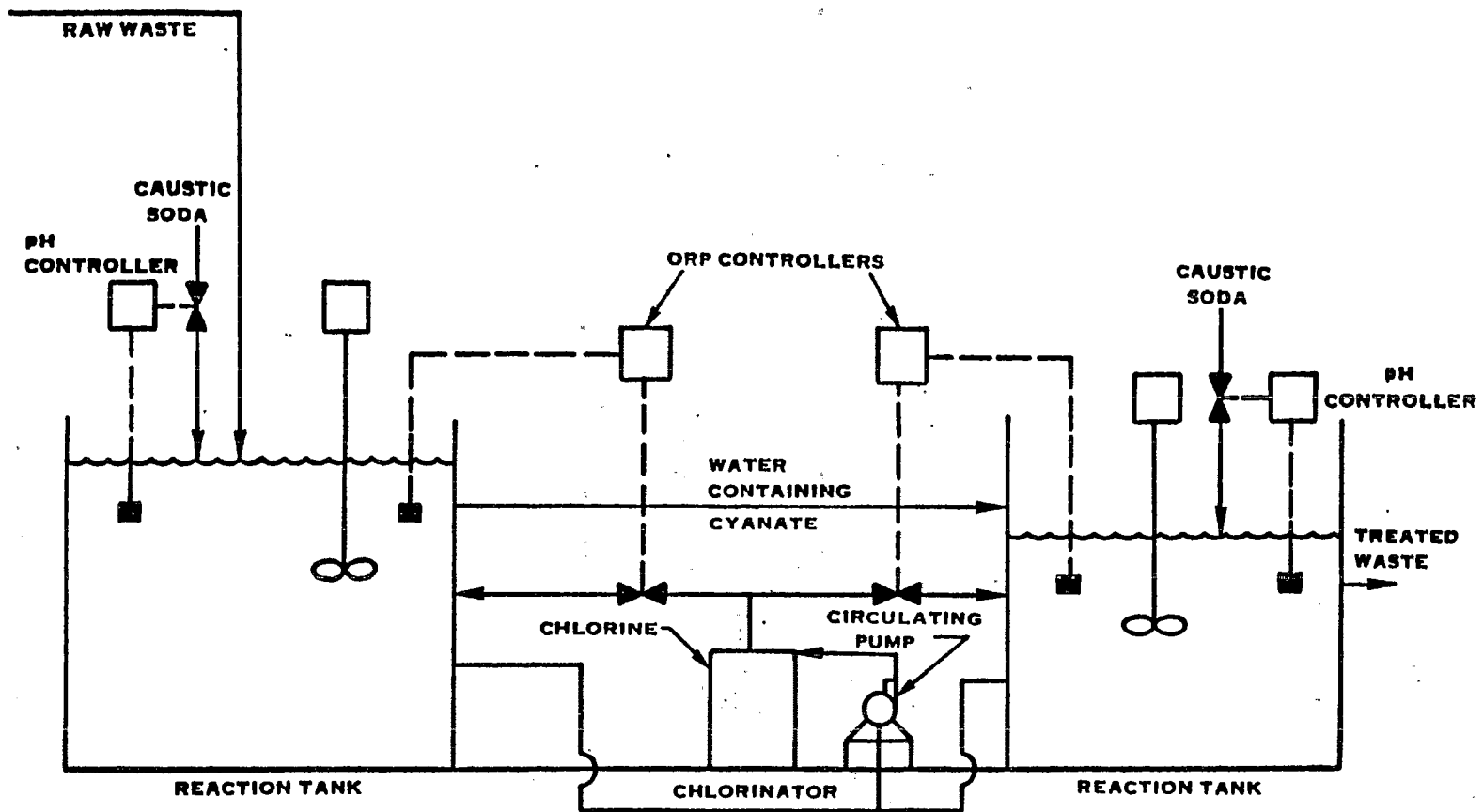

FIGURE VII-19. TREATMENT OF CYANIDE WASTE BY ALKALINE CHLORINATION

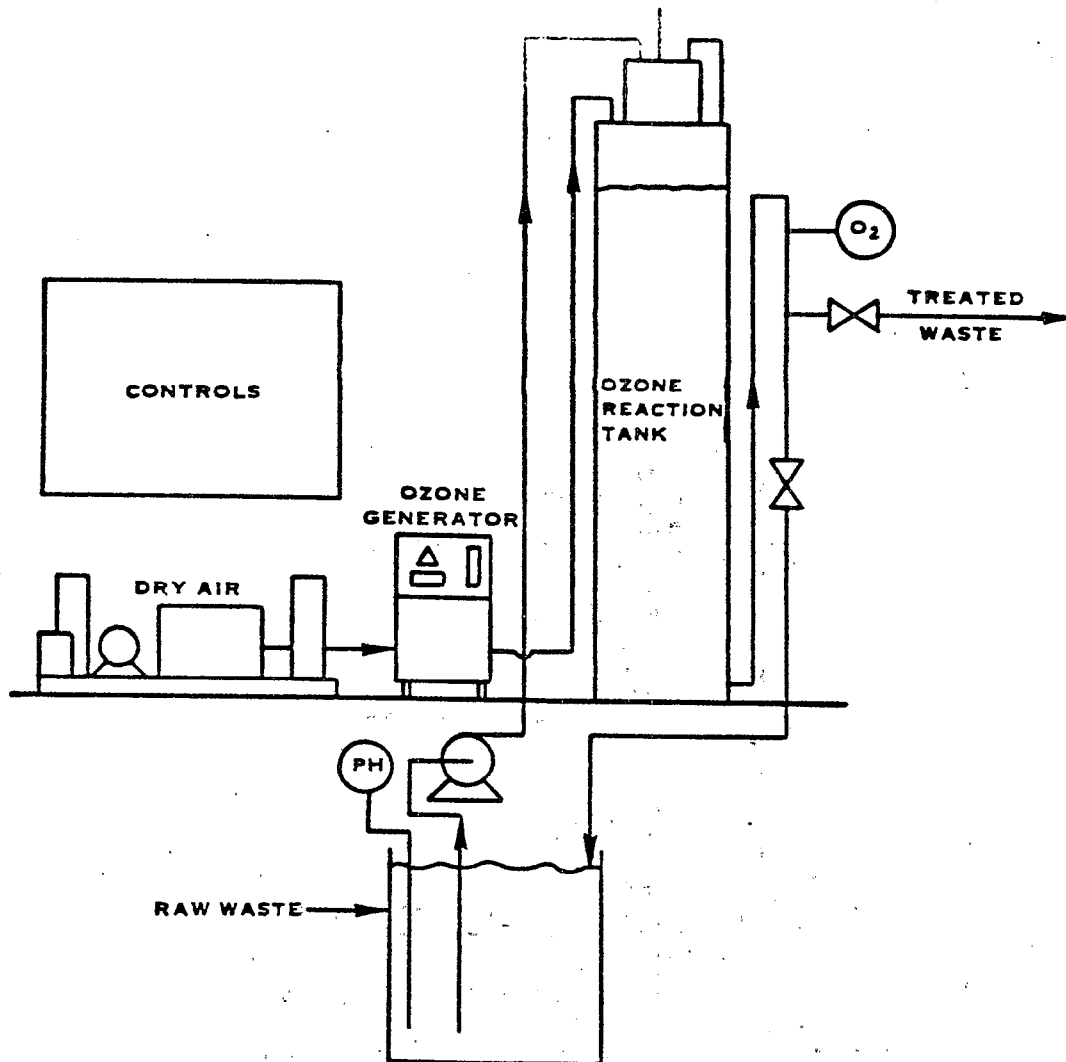

FIGURE VII-20. TYPICAL OZONE PLANT FOR WASTE TREATMENT

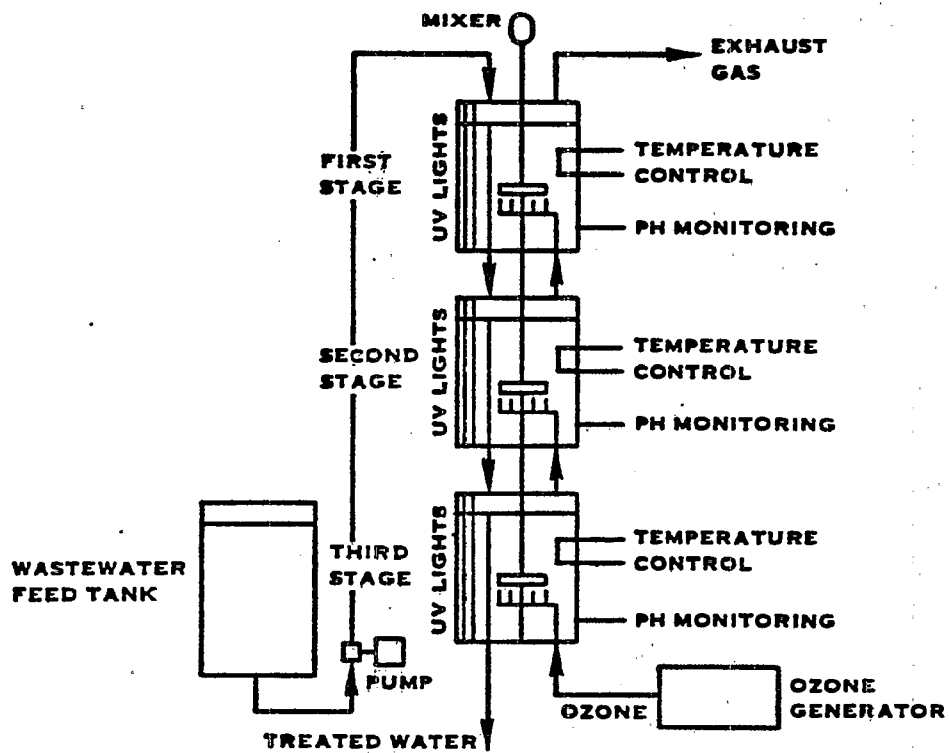

FIGURE VII-21. UV/OZONATION

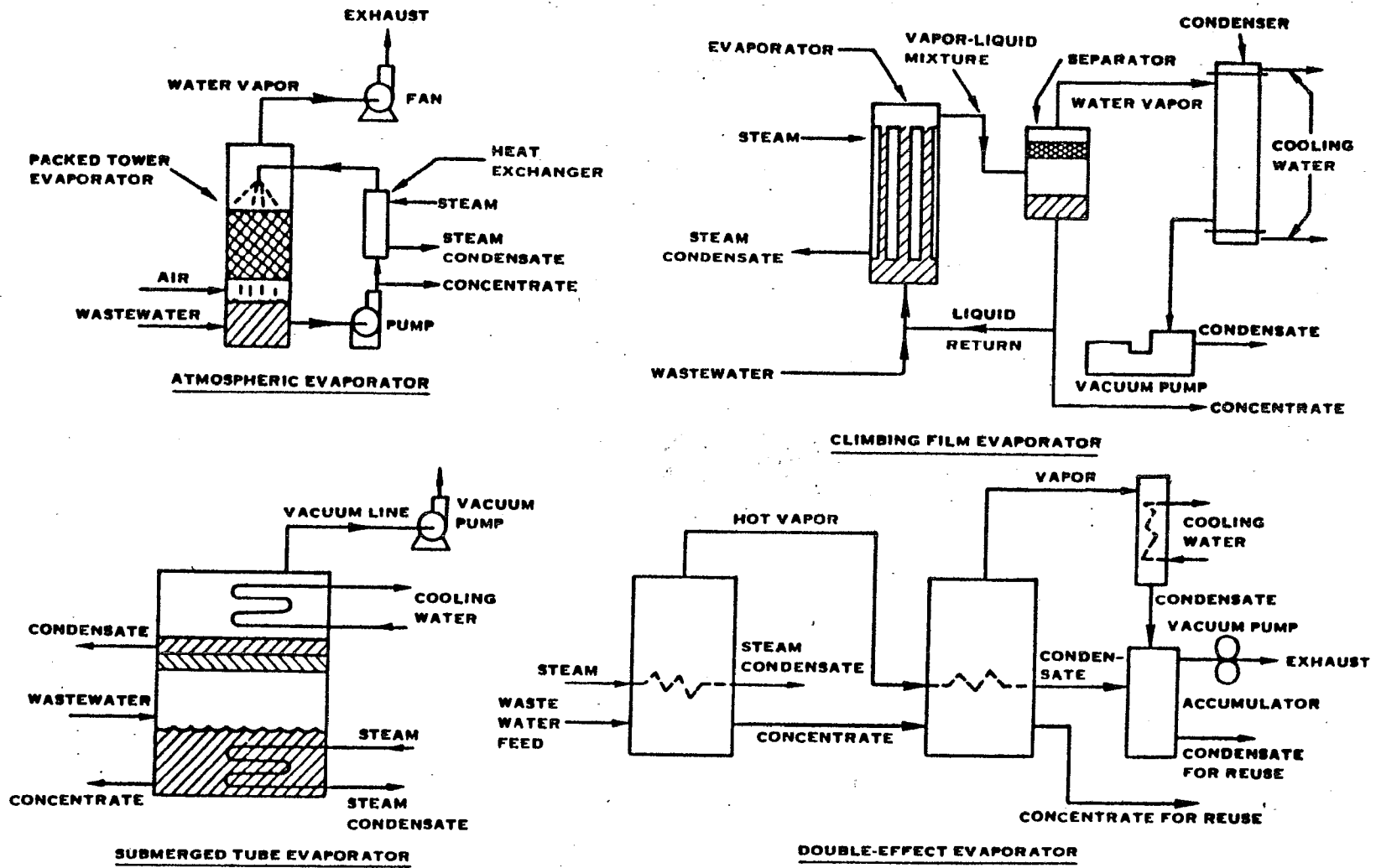

FIGURE VII-22. TYPES OF EVAPORATION EQUIPMENT

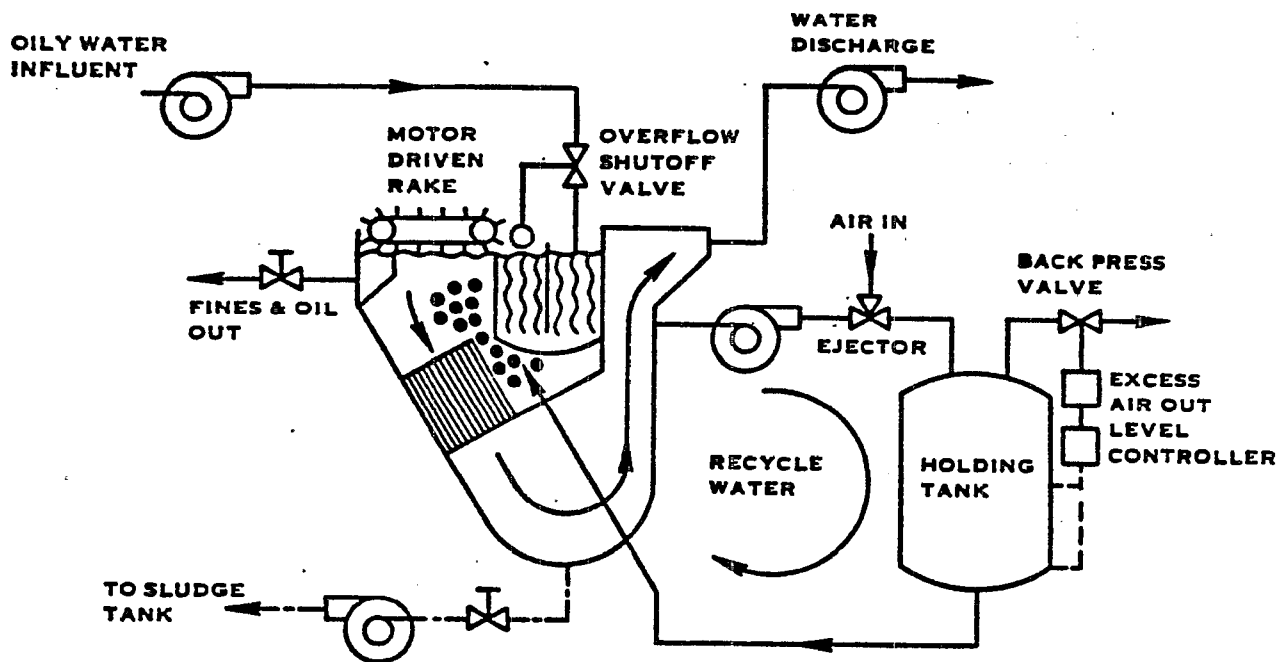

FIGURE VII-23. DISSOLVED AIR FLOTATION

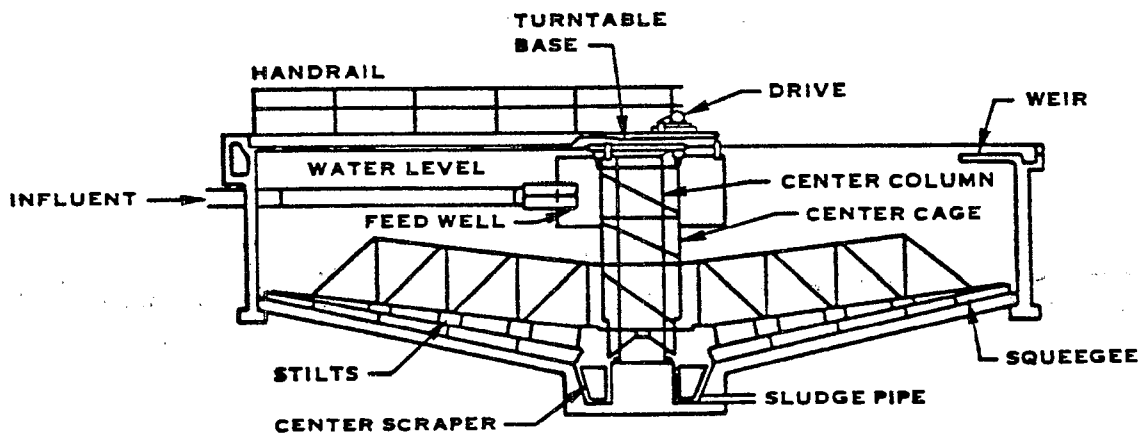
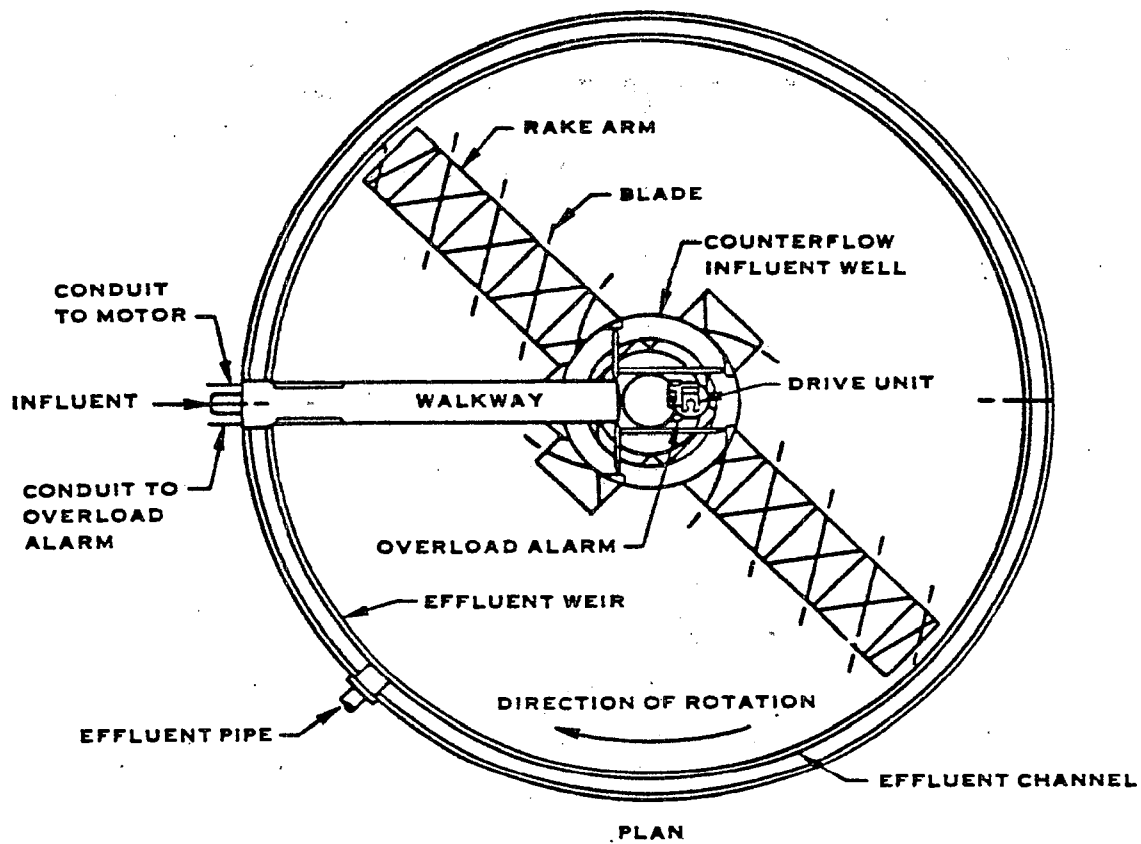

FIGURE VII-24. GRAVITY THICKENING

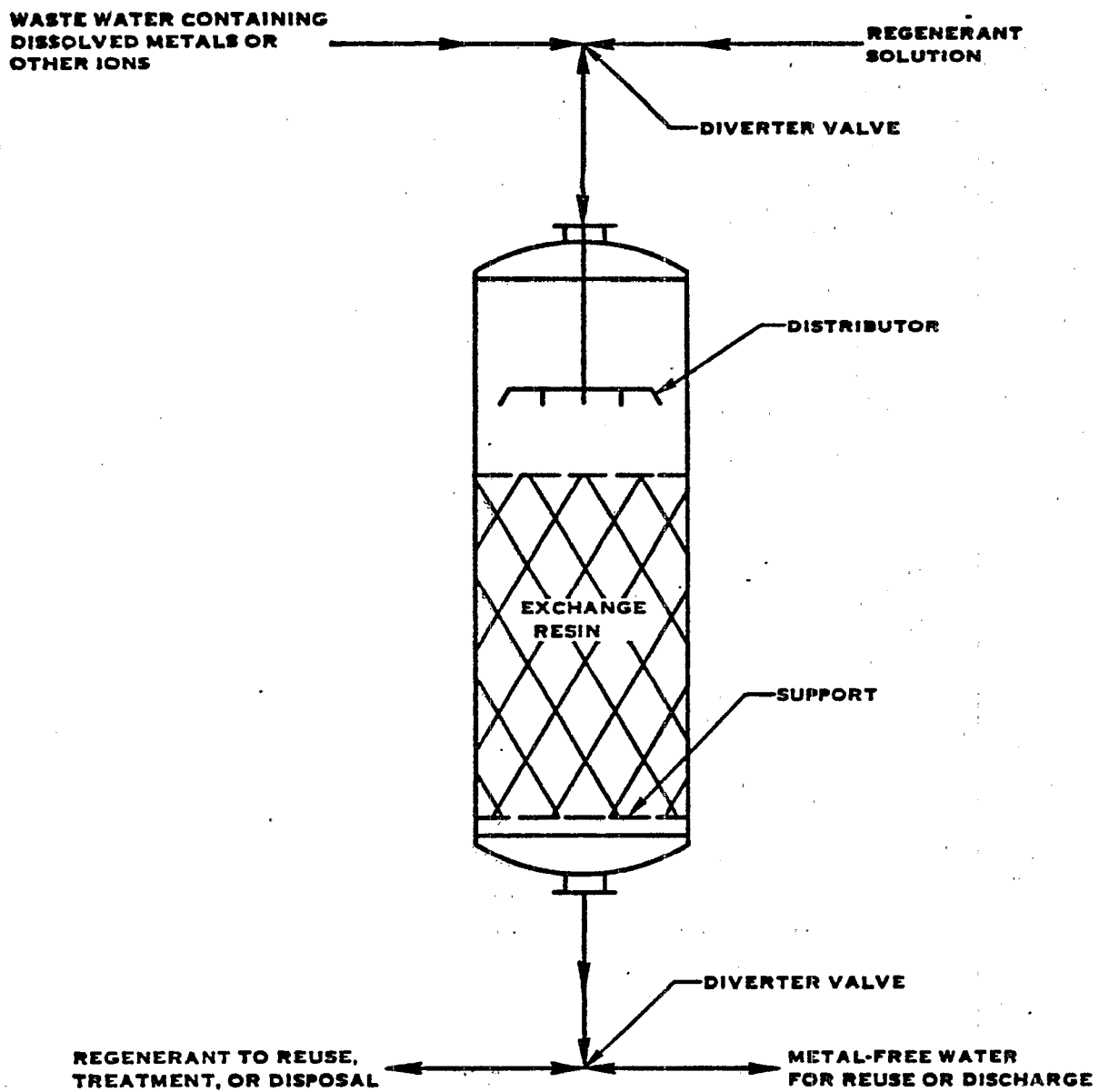

FIGURE VII-25. ION EXCHANGE WITH REGENERATION

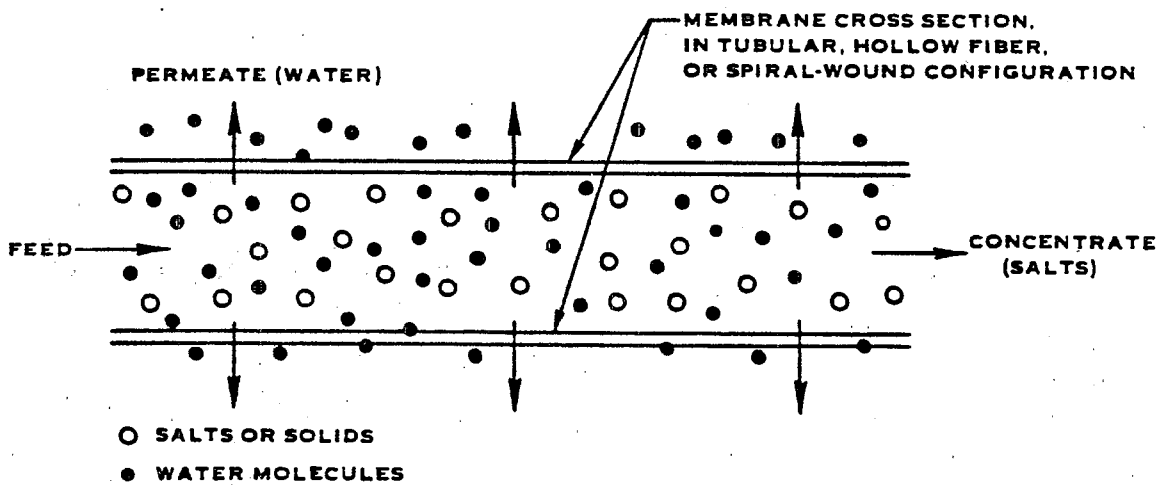
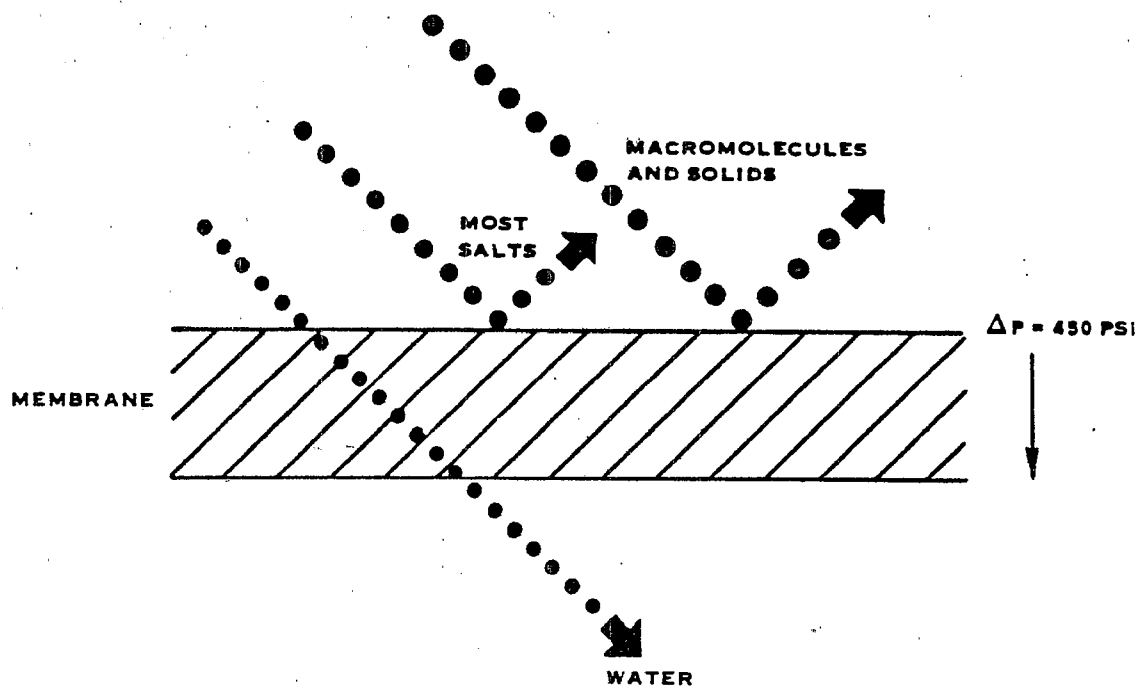

FIGURE VII-26. SIMPLIFIED REVERSE OSMOSIS SCHEMATIC

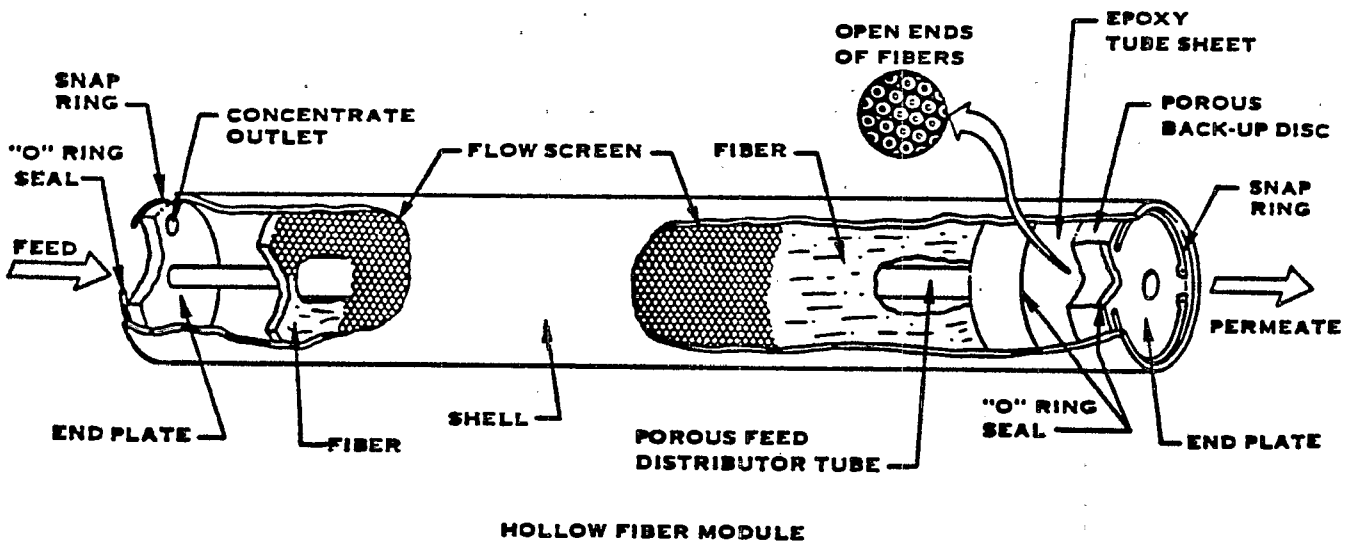
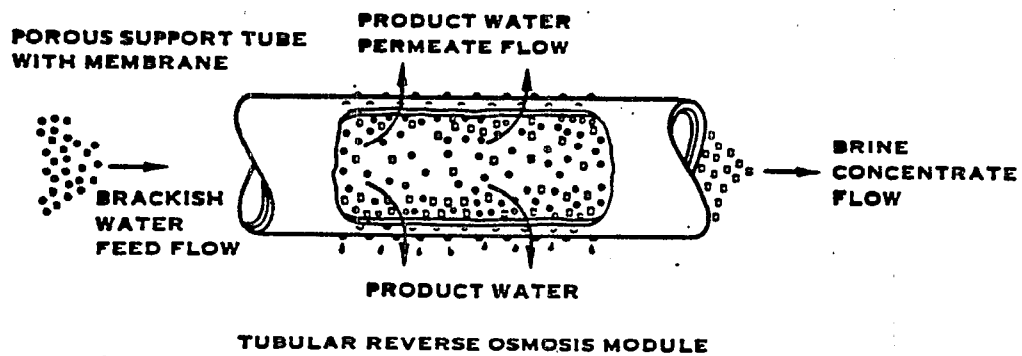
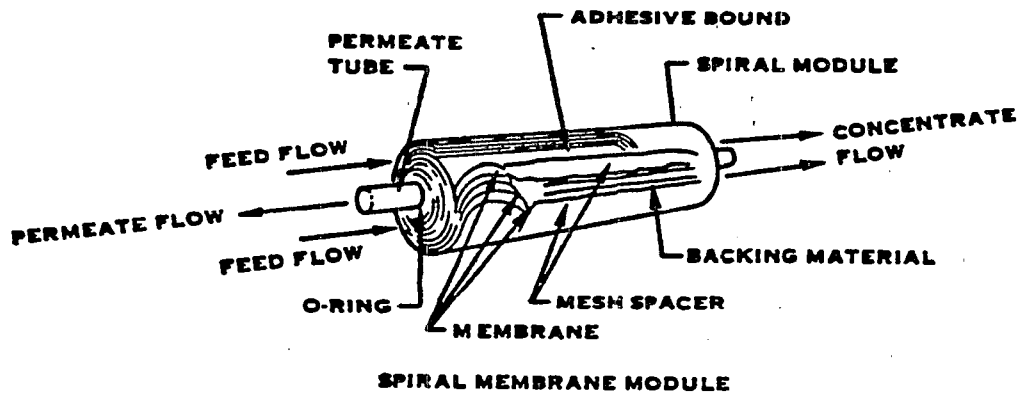

FIGURE VII-27. REVERSE OSMOSIS MEMBRANE CONFIGURATIONS

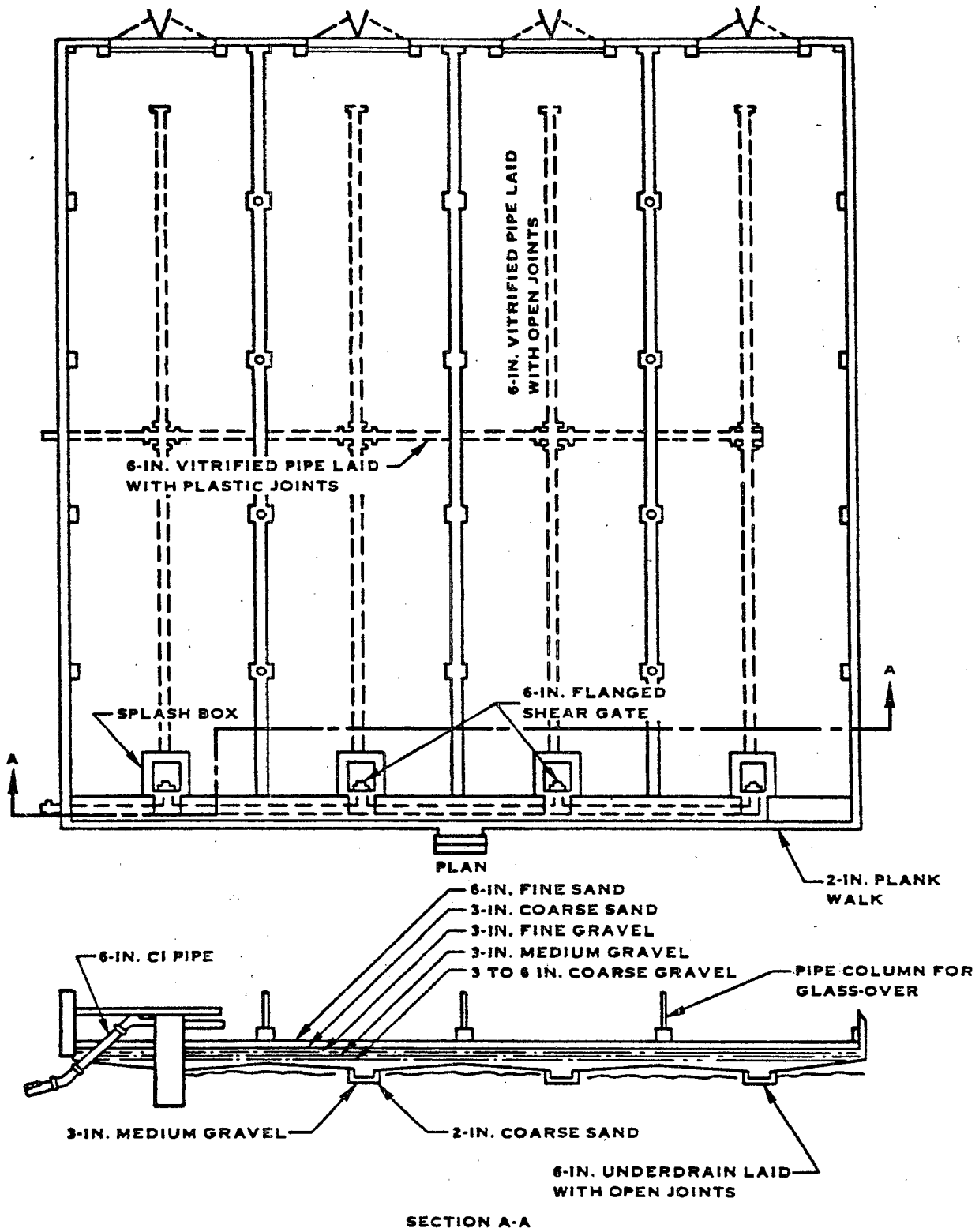

FIGURE VII-28. SLUDGE DRYING BED

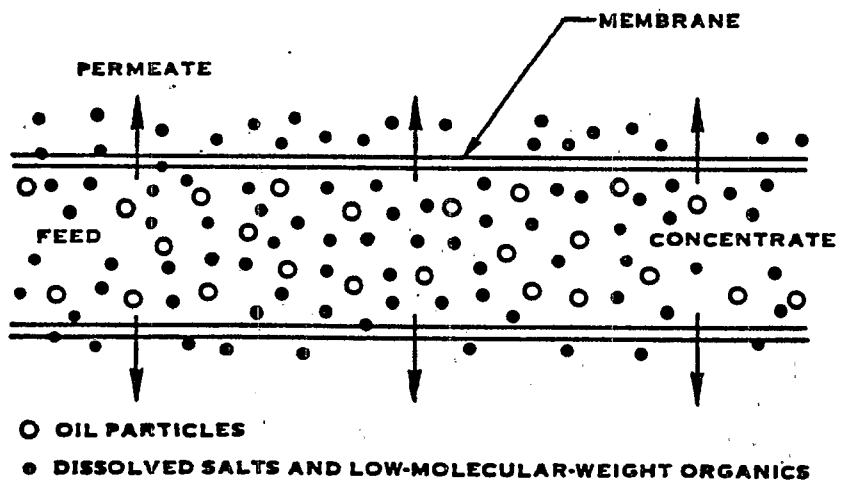
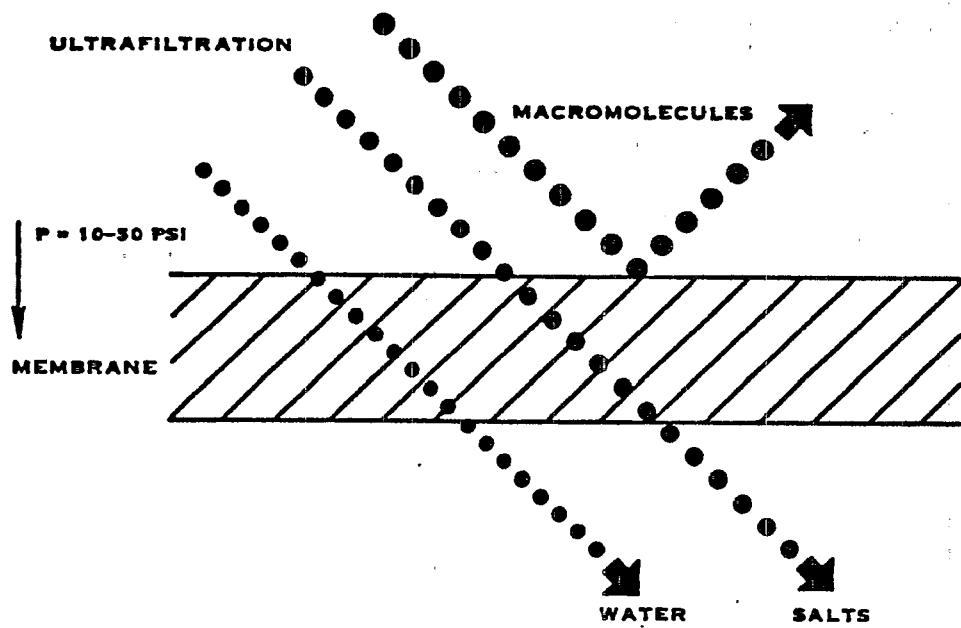

FIGURE VII-29. SIMPLIFIED ULTRAFILTRATION FLOW SCHEMATIC

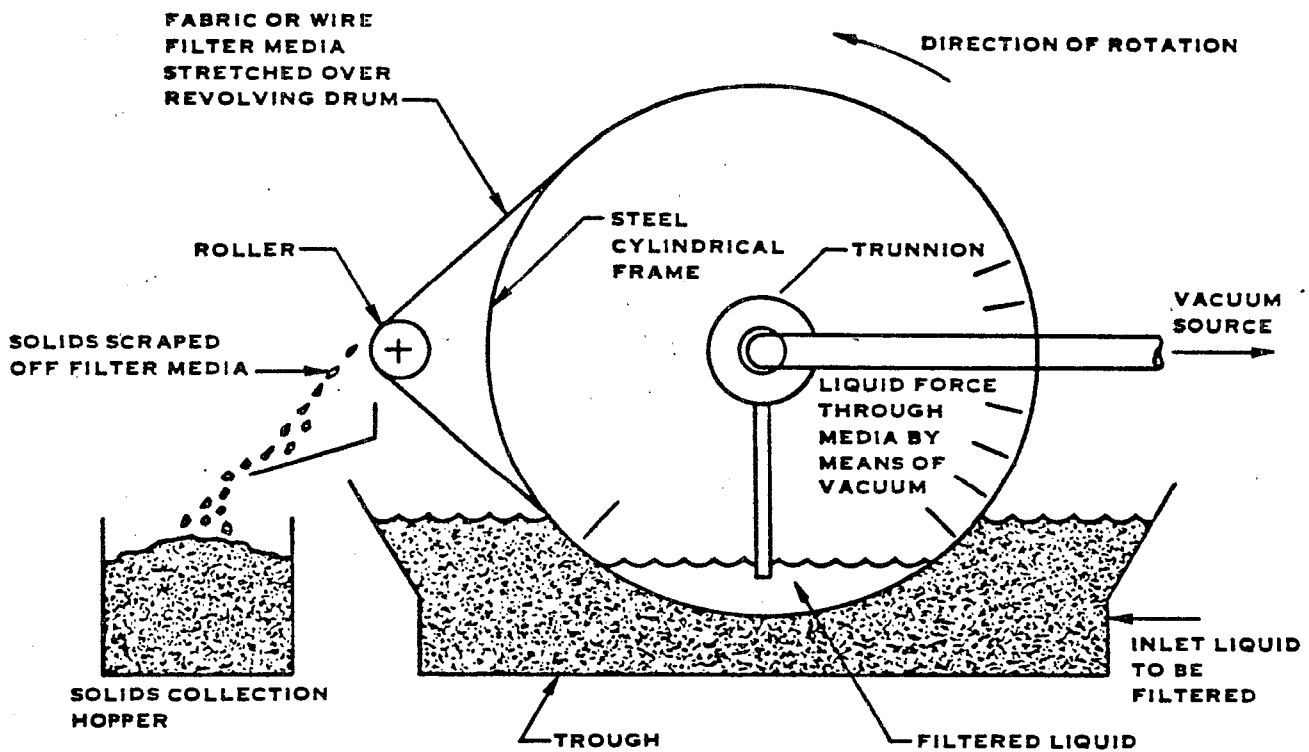

FIGURE VII-30. VACUUM FILTRATION

1452

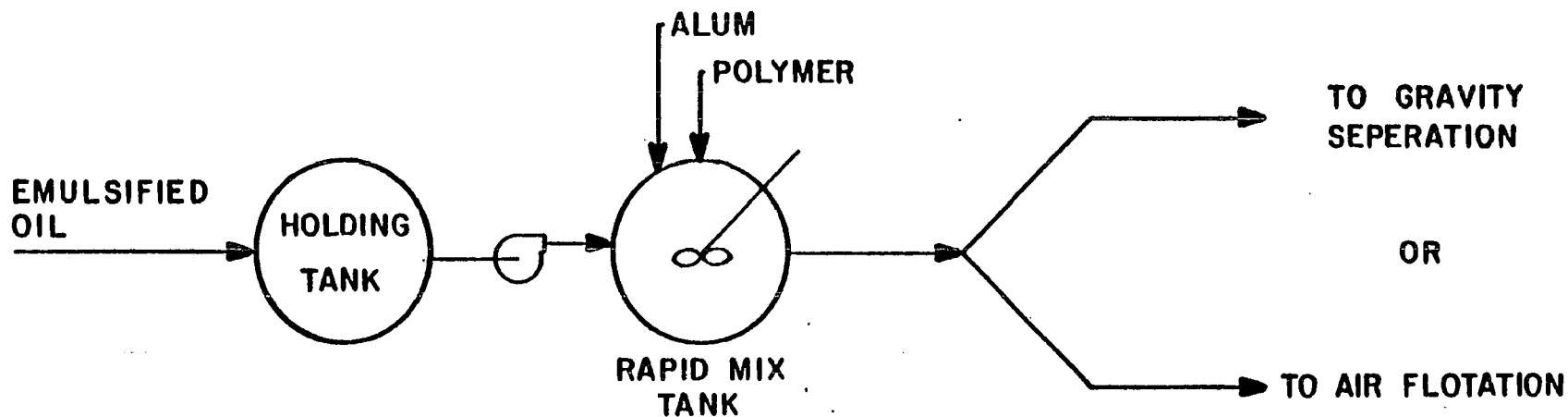

Figure VII-31

FLOW DIAGRAM FOR EMULSION BREAKING WITH CHEMICALS

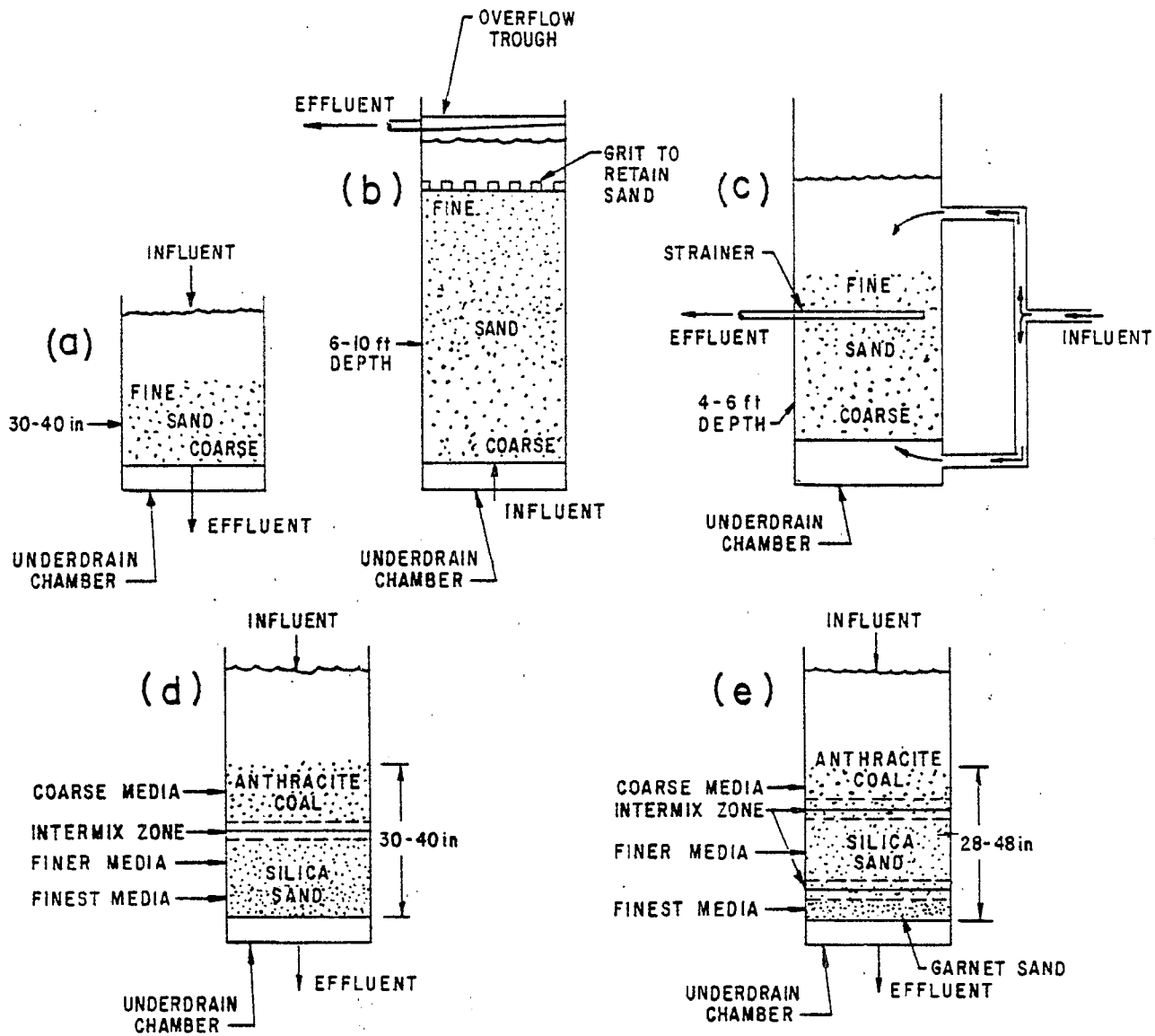

Figure VII-32

FILTER CONFIGURATIONS

- (a) Single-Media Conventional Filter.
- (b) Single-Media Upflow Filter.
- (c) Single-Media Biflow Filter.
- (d) Dual-Media Filter.
- (e) Mixed-Media (Triple-Media) Filter.

1454

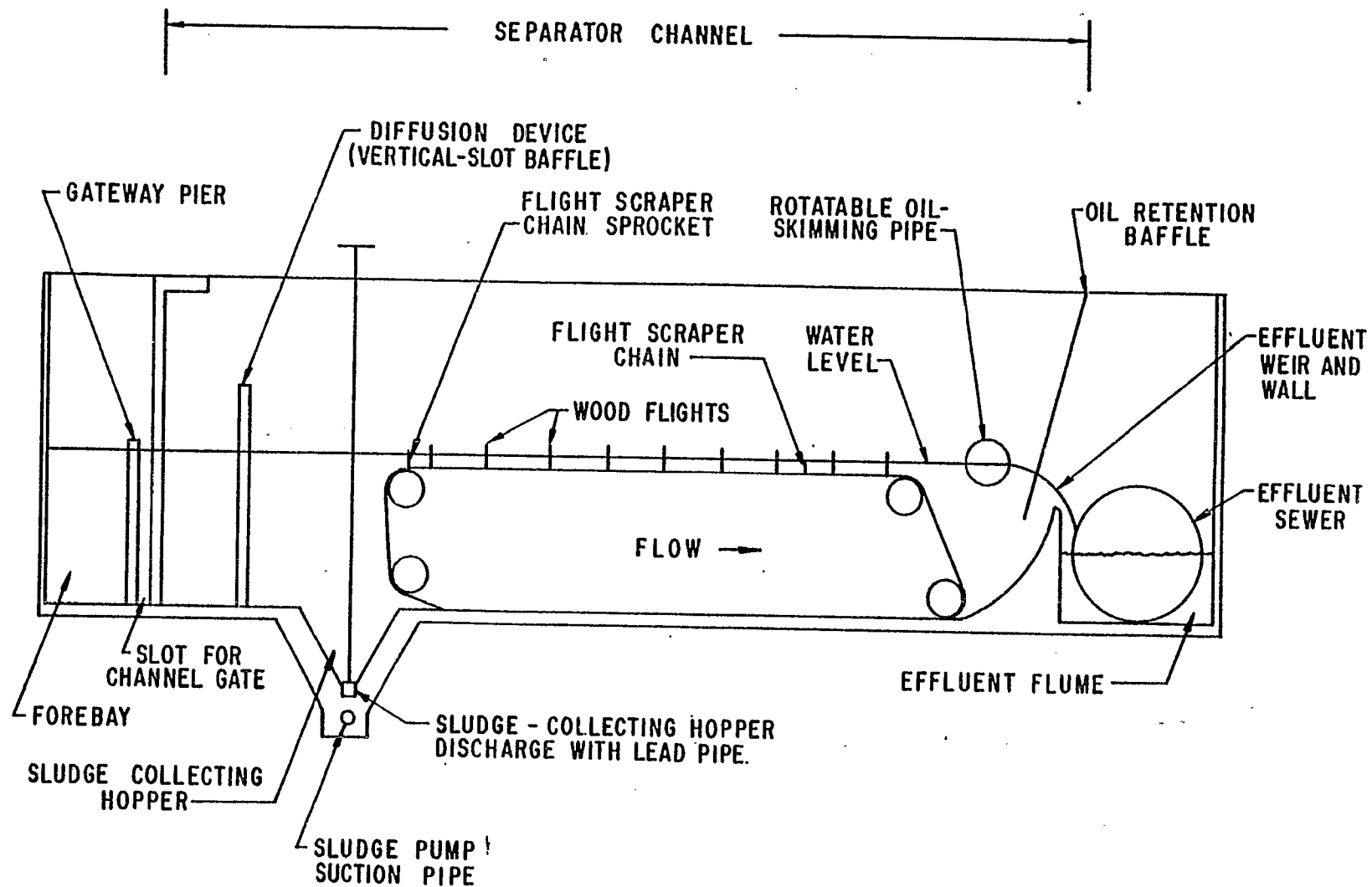

Figure VII-33

GRAVITY OIL/WATER SEPARATOR

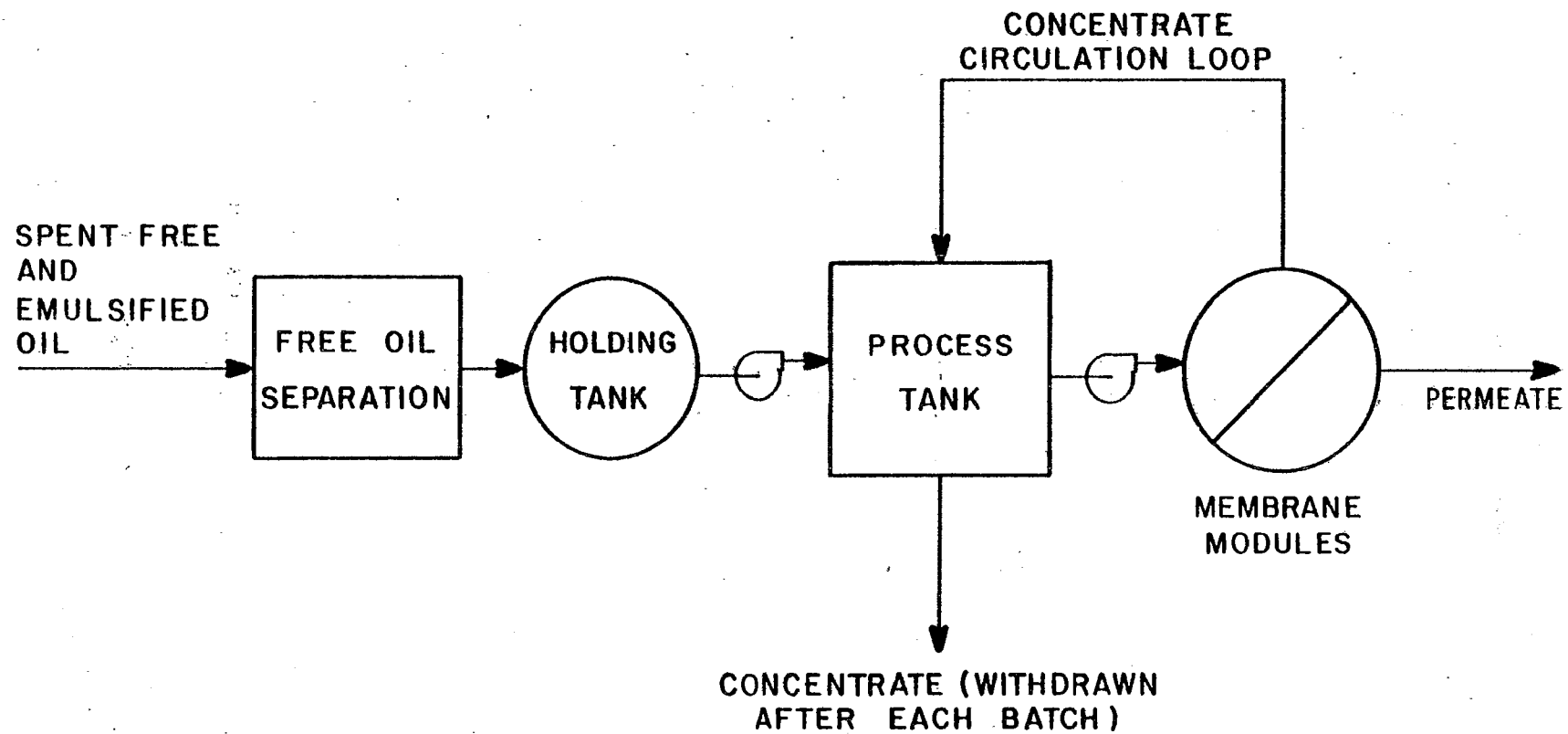
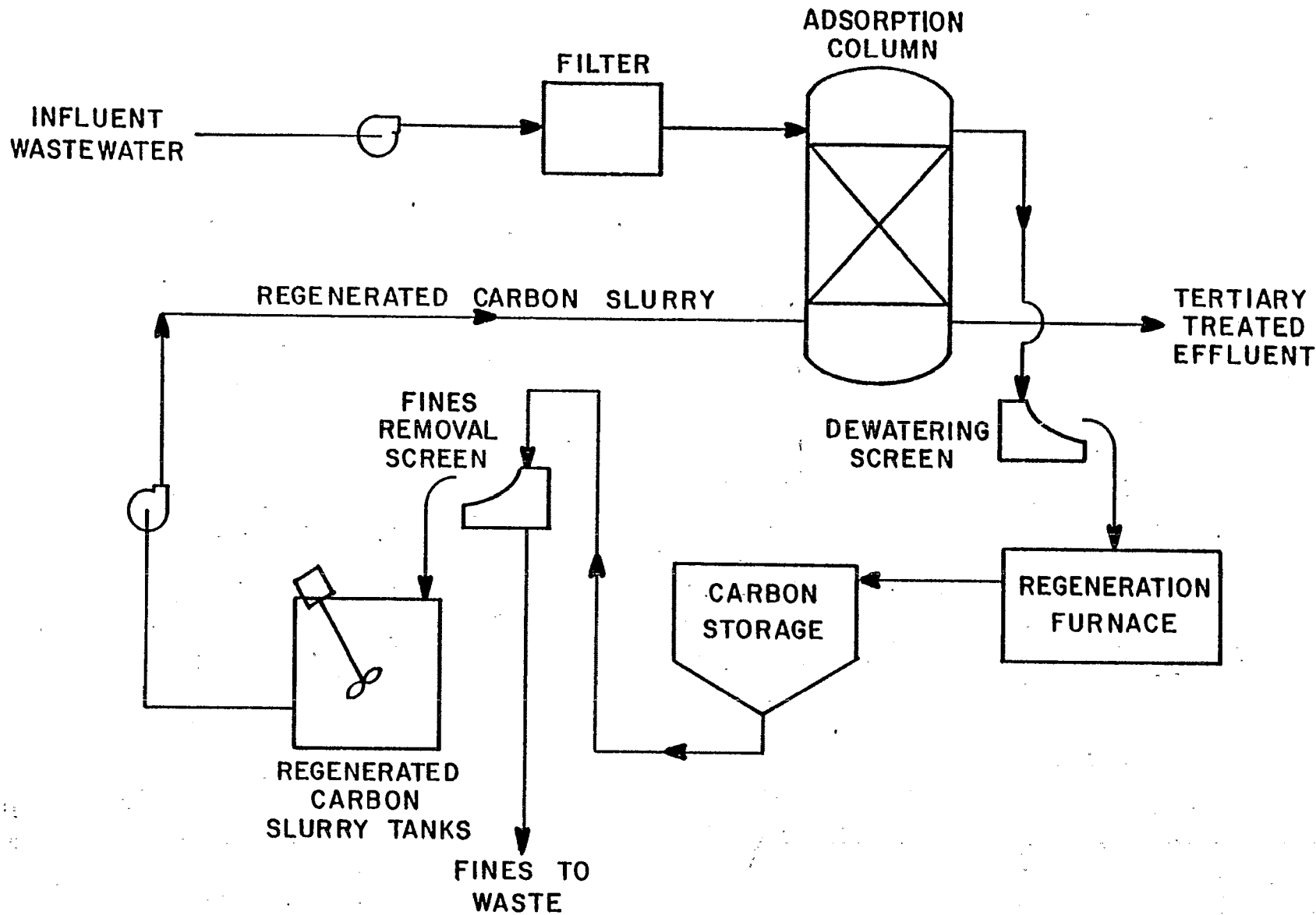

Figure VII-34

FLOW DIAGRAM FOR A BATCH TREATMENT ULTRAFILTRATION SYSTEM



1456

Figure VII-35

FLOW DIAGRAM OF ACTIVATED CARBON ADSORPTION WITH REGENERATION

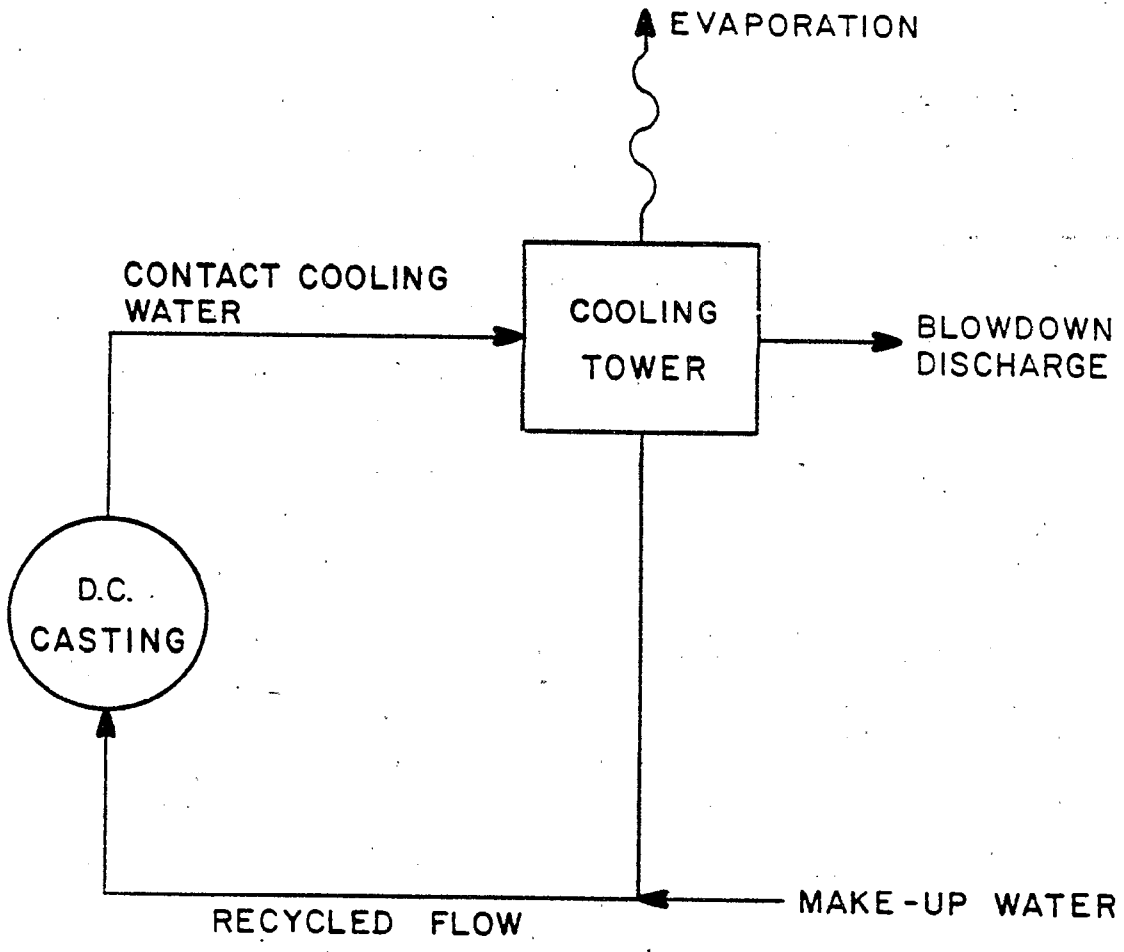
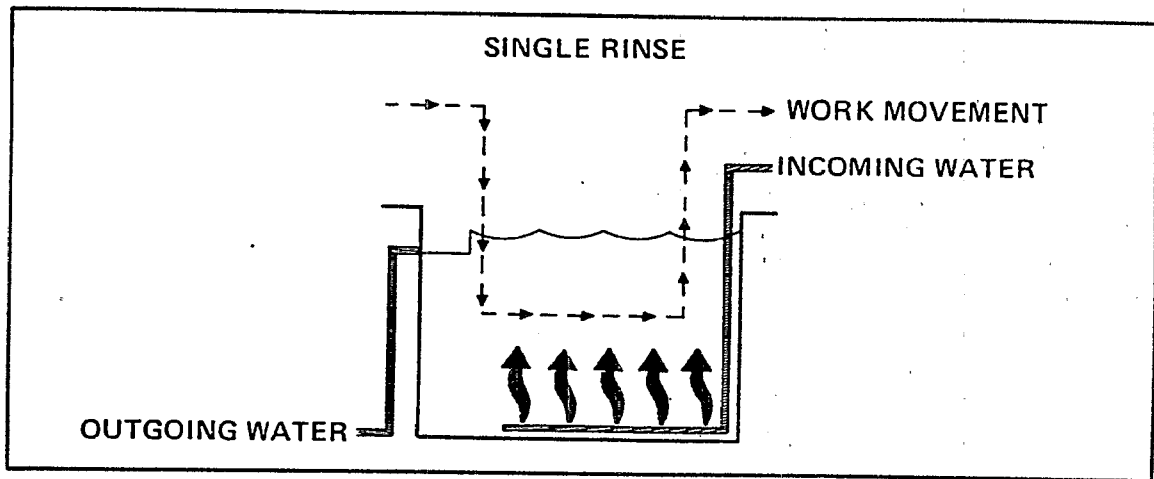
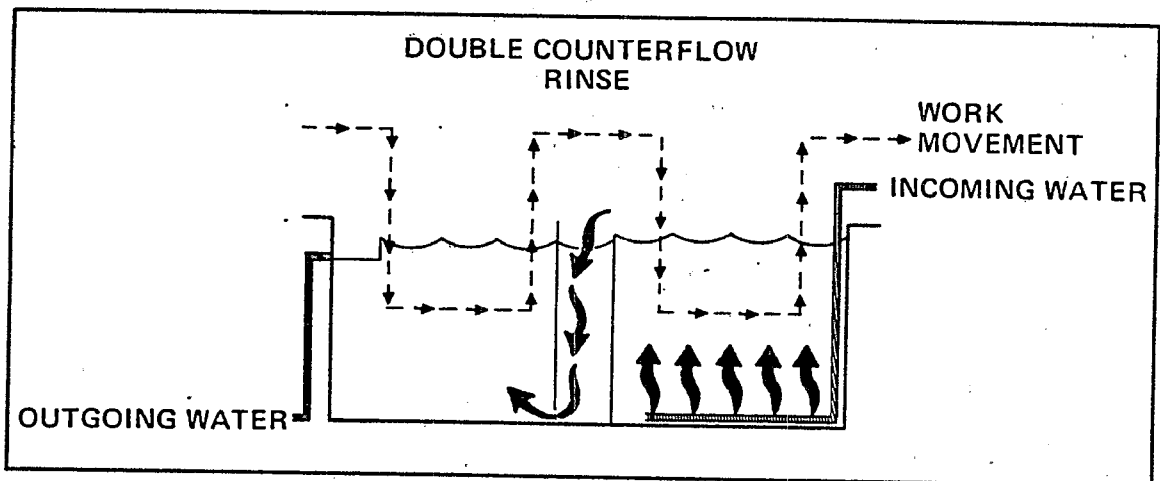

Figure VII-36

FLOW DIAGRAM FOR RECYCLING WITH A COOLING TOWER



a



b

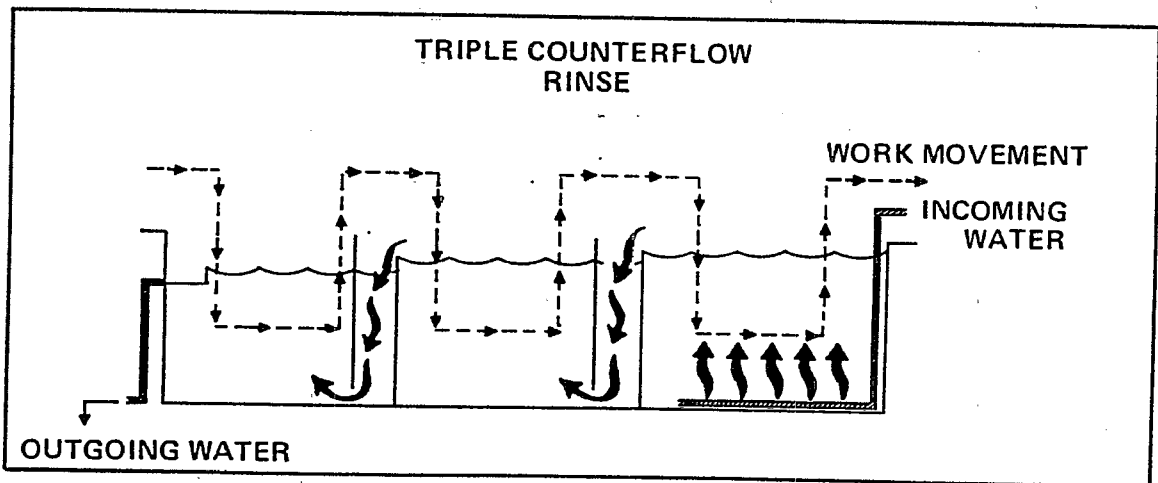

c

Figure VII-37
COUNTER CURRENT RINSING (TANKS)

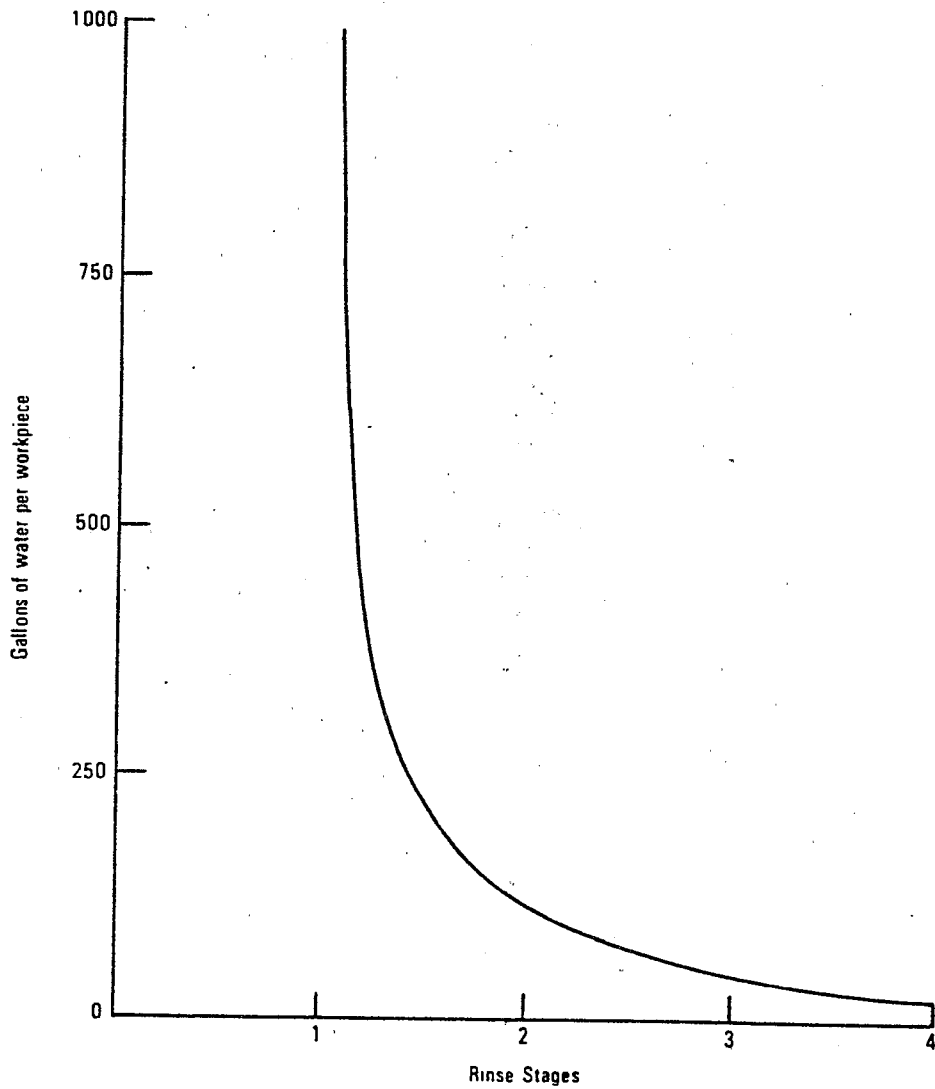
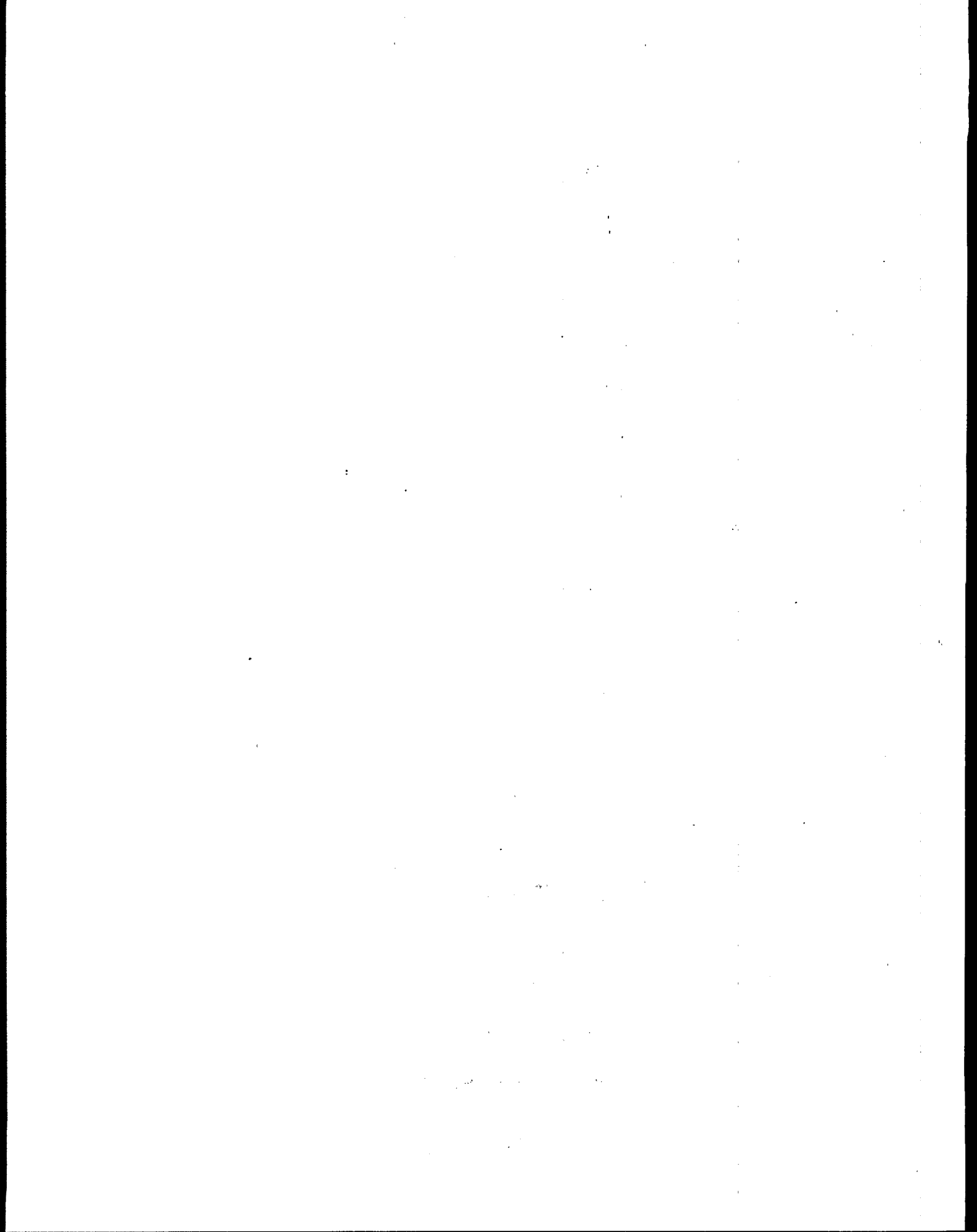

Figure VII-38

EFFECT OF ADDED RINSE STAGES ON WATER USE



SECTION VIII

COST OF WASTEWATER TREATMENT AND CONTROL

This section contains a summary of cost estimates, a discussion of the cost methodology used to develop these estimates, and descriptions of the equipment and assumptions for each individual treatment technology. These cost estimates, together with the estimated pollutant reduction performance for each treatment and control option presented in Sections IX, X, XI, and XII, provide a basis for evaluating each regulatory option. The cost estimates also provide the basis for determining the probable economic impact of regulation on the category at different pollutant discharge levels. In addition, this section addresses nonwater quality environmental impacts of wastewater treatment and control alternatives, including air pollution, solid wastes, and energy requirements.

SUMMARY OF COST ESTIMATES

The total capital and annual costs of compliance associated with the final regulation are presented by subcategory in Tables VIII-1 through VIII-3 for regulatory options BPT, BAT, and PSES, respectively. The number of direct and indirect discharging plants in each subcategory is also shown. The cost estimation methodology used to obtain these plant cost estimates is described in the following subsection.

COST ESTIMATION METHODOLOGY

Two general approaches to cost estimation are possible. The first is a plant-by-plant approach in which costs are estimated for each individual plant in the category. Alternatively, in a model plant approach, costs can be projected for an entire category (or subcategory) based on cost estimates for an appropriately selected subset of plants. The plant-by-plant cost estimation procedure is usually preferred compared with the model plant approach because it maximizes the use of plant specific data.

To implement the selected approach, the wastewater characteristics and appropriate treatment technologies for the category are identified. These are discussed in Section V and Section VII of this document, respectively. Based on a preliminary technical and economic evaluation, the model treatment systems are developed for each regulatory option from the available set of treatment processes. When these systems are established, a cost data base is developed containing capital and operating costs for each applicable technology. To apply this data base to each plant for cost estimation, the following steps are taken:

1. Define the components of the treatment system (e.g., chemical precipitation, multimedia filtration) that are applicable to the waste streams under consideration at the plant and their sequence.
2. Define the flows and pollutant concentrations of the waste streams entering the treatment system.
3. Estimate capital and annual costs for this treatment system.
4. Estimate the actual compliance costs by accounting for and subtracting the costs for existing treatment-in-place.
5. Repeat steps 1-4 for each regulatory option.

In this subsection, the changes made in the cost estimation methodology from proposal are presented first. Following this, each of the elements of the cost estimation procedure are presented. This includes development of the cost data base, the plant profile data base, and the wastewater characterization data base. The subsection concludes with a discussion of the three methods used for treatment system cost estimation-application of a computer cost estimation model, use of cost curves and equations, and scaling of costs from similar plants.

Cost Data Base Development

A preliminary step required prior to cost estimation is the development of a cost data base, which includes the compilation of cost data and standardization of the data to a common dollar basis. The sources of cost data, the components of the cost estimates, and the update factors used for standardization (to March 1982 dollars in this case) are described below.

Sources of Cost Data

Capital and annual cost data for the selected treatment processes were obtained from three sources: (1) equipment manufacturers, (2) literature data, and (3) cost data from existing plants. The major source of equipment costs was contacts with equipment vendors, while the majority of annual cost information was obtained from the literature. Additional cost and design data were obtained from data collection portfolios when possible.

Components of Costs

The components of the capital and annual costs and the terminology used in this study are presented here in order to ensure unambiguous interpretation of the cost estimates and cost curves included in this section.

Capital Costs. The total capital costs consist of two major components: direct, or total module capital costs and indirect, or system capital costs. The direct capital costs include:

- (1) Purchased equipment cost,
- (2) Delivery charges (based on shipping distance of 500 miles), and
- (3) Installation (including labor, excavation, site work, and materials).

The direct components of the total capital cost are derived separately for each unit process, or treatment technology. In this particular case, each unit process cost includes individual equipment costs (e.g., pumps, tanks, feed systems, etc.). The correlating equations used to generate the individual equipment costs are presented in Table VIII-4.

Indirect capital costs consist of contingency, engineering, and contractor fees. These indirect costs are derived from factored estimates, i.e., they are estimated as percentages of a subtotal of the total capital cost, as shown in Table VIII-5.

Annual Costs. The total annualized costs also consist of both a direct and a system component as in the case of total capital costs. The components of the total annualized costs are listed in Table VIII-6. Direct annual costs include the following:

- o Raw materials - These costs are for chemicals and other materials used in the treatment processes, which may include lime, caustic, sodium thiosulfate, sulfur dioxide, ion exchange resins, sulfuric acid, hydrochloric acid, ferrous sulfate, ferric chloride, and polyelectrolyte.
- o Operating labor and materials - These costs account for the labor and materials directly associated with operation of the process equipment. Labor requirements are estimated in terms of hours per year. A labor rate of \$21 per hour was used to convert the hour requirements into an annual cost. This composite labor rate included a base labor rate of \$9 per hour for skilled labor, 15 percent of the base labor rate for supervision and plant overhead at 100 percent of the total labor rate. The base labor rate was obtained from the "Monthly Labor Review," which is published by the Bureau of Labor Statistics of the U.S. Department of Labor. For the metals industry, this wage rate was approximately \$9 per hour in March of 1982.

- o Maintenance labor and materials - These costs account for the labor and materials required for repair and routine maintenance of the equipment. They are based on information gathered from the open literature and from equipment vendors.
- o Energy - Energy, or power, costs are calculated based on total energy requirements (in kW-hrs), an electricity charge of \$0.0483/kilowatt-hour and an operating schedule of 24 hours/day, 250 days/year unless specified otherwise. The electricity charge rate (March 1982) is based on the average retail electricity prices charged for industrial service by selected Class A privately-owned utilities, as reported in the Department of Energy's Monthly Energy Review.

System annual costs include monitoring, insurance and amortization. Monitoring refers to the periodic analysis of wastewater effluent samples to ensure that discharge limitations are being met. The annual cost of monitoring was calculated using an analytical lab fee of \$120 per wastewater sample and a sampling frequency based on the wastewater discharge rate, as shown in Table VIII-7, page . The values shown in Table VIII-7 represent typical requirements contained in NPDES permits. For the economic impact analysis, the Agency also estimated monitoring costs based on 10 samples per month, which is consistent with the statistical basis for the monthly limit.

The cost of taxes and insurance is assumed to be one percent of the total depreciable capital investment.

Amortization costs, which account for depreciation and the cost of financing, were calculated using a capital recovery factor (CRF). A CRF value of 0.177 was used, which is based on an interest rate of 12 percent, and a taxable lifetime of 10 years. The CRF is multiplied by the total depreciable investment to obtain the annual amortization costs.

Standardization of Cost Data

All capital and annual cost data were standardized by adjusting to March 1982 dollars based on the following cost indices.

Capital Investment. Investment costs were adjusted using the EPA-Sewage Treatment Plant Construction Cost Index. The value of this index for March 1982 is 414.0.

Chemicals. The Chemical Engineering Producer Price Index for industrial chemicals is used. This index is published biweekly in Chemical Engineering magazine. The March 1982 value of this index is 362.6.

Energy. Power costs are adjusted by using the price of electricity on the desired date and multiplying it by the energy requirements for the treatment module in kW-hr equivalents. The

industrial charge rate for electricity for March 1982 is \$0.0483 per kW-hr as mentioned previously in the annual costs discussion.

Labor. Annual costs are adjusted by multiplying the hourly labor rate by the labor requirements (in labor-hours), if the latter is known. The labor rate for March 1982 was assumed to be \$21 per hour (see above). In cases where the labor-hour requirements are unknown, the annual labor costs are updated using the EPA-Sewage Treatment Plant Construction Cost Index. The value of this index for March 1982 is 414.0 as stated above.

Plant Specific Flowsheet

After the cost data base have been developed, the next step of the cost estimation procedure is the selection of the appropriate treatment technologies and their sequence for a particular plant. These are determined for a given regulatory option by applying the general treatment diagram for that subcategory to the plant. This general option diagram is modified as appropriate to reflect the specific treatment technologies that the plant will require. For instance, one plant in a subcategory may generate wastewater from a certain operation that requires oil-water separation. Another plant in the same subcategory may not generate this waste stream and thus may not require oil-water separation technology. The specific plant flowsheets will reflect this difference.

Wastewater Characteristics

Upon establishing the appropriate flowsheet for a given plant, the next step is to define the influent waste stream characteristics (flow and pollutant concentrations).

The list of pollutants which may influence the design (and thus the cost) of the treatment system is shown in Table VIII-8. This list includes the conventional, priority metal, and selected nonconventional pollutants that are generally found in metal-bearing waste streams. Varying influent concentrations will affect the various wastewater treatment processes. For example, influent waste streams with high metals loadings require a greater volume of precipitant (such as lime) and generate a greater amount of sludge than waste streams with lower metals concentrations.

The raw waste concentrations of pollutants present in the influent waste streams for cost estimation were based primarily on field sampling data. A production normalized raw waste value in milligrams of pollutant per metric ton of production was calculated for each pollutant by multiplying the measured concentration by the corresponding waste stream flow and dividing this result by the corresponding production associated with generation of the waste stream. These raw waste values are averaged across all sampled plants where the waste stream is found. These final raw waste values are used in the cost estimation procedure to establish influent pollutant loadings to each plant's treatment system. The underlying assumption in this

approach is that the amount of pollutant that is discharged by a process is a function of the off-mass of product that is produced by the process. The amount of water used in the process is assumed to not affect the mass of pollutant discharged. This assumption is also called the constant mass assumption since the mass of pollutant discharged remains the same even if the flow of water carrying the pollutant is changed.

The individual flows for cost estimation are determined for each waste stream. The procedure used to derive these flows is as follows:

- (1) The production normalized flows (l/kkg) were determined for each waste stream based on production (kkg/yr) and current flow (l/yr) data obtained from each plant's dcp or trip report data where possible.
- (2) This flow was compared to the regulatory flow allowance (l/kkg) established by the Agency for each waste stream.
- (3) The lower of the two flows was selected as the cost estimation flow. The flow in l/yr is calculated by multiplying the selected flow by the production associated with that waste stream.
- (4) The regulatory flow was assigned to waste streams for which actual flow rate data were unavailable for a plant.

In the nonferrous metals forming category, production and flow information was not available for all plants. For these facilities, the best approach is to use either the cost curves (which are based on general assumptions of the pertinent wastewater characteristics) or scaling costs based on analogous plants. These approaches, and where each was used, are discussed later in this section.

Treatment System Cost Estimation

Costs for the nonferrous metals forming category were estimated in one of three ways: (1) through use of a computer cost estimation model, (2) through use of cost curves, or (3) through scaling of costs from other similar facilities. Selecting the appropriate method for each plant was based primarily on the quality and timeliness of the information available for that plant. Where complete information (flows, production, analytical data, in-place treatment technology) was available, the computer cost estimation model or the cost curves were selected. The cost curves were generally developed using the same algorithms used in the cost estimation model, and thus the two cost estimation methods give comparable results. The cost scaling procedure was selected for plants with nonferrous metals forming wastewater flows of less than 5 percent of the plant's total wastewater flow, or where available information was so sparse that use of

one of the other two procedures was precluded. Each procedure is discussed in detail below.

Cost Estimation Model

The computer-based cost estimation model was designed to provide conceptual wastewater treatment design and cost estimates based on wastewater flows, pollutant loadings, and unit operations that are specified by the user. The model was developed using a modular approach; that is, individual wastewater treatment processes such as gravity settling are contained in semi-independent entities known as modules. These modules are used as building blocks in the determination of the treatment system flow diagram. Because this approach allows substantial flexibility in treatment system cost estimation, the model did not require modification for each regulatory option.

Each module was developed by coupling design information from the technical literature with actual design data from operating plants. This results in a more realistic design than using either theoretical or actual data alone, and correspondingly more accurate cost estimates. The fundamental units for cost estimation are not the modules themselves but the components within each module. These components range in configuration from a single piece of equipment, such as a pump to components with several individual pieces, such as a lime feed system. Each component is sized based on one or more fundamental parameters. For instance, the lime feed system is sized by calculating the lime dosage required to adjust the pH of the influent to 9 and precipitate dissolved pollutants. Thus, a larger feed system would be designed for a chemical precipitation unit treating wastewater containing high concentrations of dissolved metals than for one treating wastewater of the same flow rate but lower metals loadings.

The cost estimation model consists of four main parts, or categories of programs:

- o User input programs,
- o Design and simulation programs,
- o Cost estimation programs, and
- o Auxiliary programs.

A general logic diagram depicting the overall calculational sequence is shown in Figure VIII-1.

The user input programs allow entry of all data required by the model, including the plant specific flowsheet, flow and composition data for each waste stream, and specification of recycle loops. The design portion of the model calculates the design parameter for each module of the flowsheet based on the user input and material balances performed around each module. Figure VIII-2, depicts the logic flow diagram for the design portion of the model.

The design parameters are used as input to the cost estimation programs to calculate the costs for each module equipment component (individual correlating cost equations were developed for each of these components). The total direct capital and annual costs are equal to the sum of the module capital and annual costs, respectively. System, or indirect costs (e.g., engineering, amortization) are then calculated (see Table VIII-5, and Table VIII-6, and added to the total direct costs to obtain the total system costs. The logic flow for the cost estimation programs is displayed in Figure VIII-3. The auxiliary programs store and transfer the final cost estimates to data files, which are then used to generate final summary tables (see Table VIII-10, for a sample summary table).

Cost Curves

The cost curves were developed using the computer cost estimation model. Therefore, the design and cost assumptions for each treatment option presented later in this section also apply to cost curve development. Several flows were selected for each treatment operation and the capital and annual costs were plotted against the flow or other design parameter. In cases where the cost was a function of two or more independent variables (e.g., countercurrent cascade rinsing), a combination of curves or curves and equations was used. To simplify the calculations, the sludge handling operations (i.e., vacuum filtration and contract hauling) cost curves were plotted as a function of influent flow to the sludge handling operation. This necessitated a calculation of the ratio of sludge produced to the influent wastewater flow. This ratio is a function of the wastewater pollutant loadings. Wastewater characteristics from the subcategories to be costed using the cost curves (nickel-cobalt, titanium, zirconium-hafnium, uranium, and refractory metals) were reviewed to determine how many sludge ratios were required to accurately reflect variation among these subcategories. This resulted in the identification of the need for four ratios. The subcategories represented by each ratio and the ratios themselves appear in Table VIII-9. The table also presents the dry sludge ratios used in cost estimation for contract hauling.

To calculate the sludge generation ratios, a model plant representative of the plants in the subcategory group was developed. This plant included those waste streams within the group that contained the highest pollutant loadings. Next, the computer cost estimation model was utilized to perform the necessary material balances around a treatment system designed for the model plant. Flows based on BAT regulatory requirements were used. From this analysis, the sludge ratios were calculated as the volume of sludge produced divided by the influent flow to treatment. In cases where the waste stream mix diverged substantially from the set of waste streams used to develop the ratio, the ratio was revised accordingly. The ratios used for each plant are documented in the public record supporting this rulemaking.

In addition to chemical precipitation, the sludge ratios for cyanide precipitation in the titanium forming subcategory were calculated. The values are 0.72 l sludge/l influent and 0.11 l sludge/l influent for wet (3 percent) sludge and for dry (20 percent) sludge, respectively.

To calculate the necessary flow to read the sludge handling curves, the influent wastewater flow is multiplied by the corresponding sludge ratio.

After the curves and equations were developed, they were validated by comparing curve-derived costs with those generated by the computer model. Average agreement within 25 percent was obtained for each treatment option.

Having verified the cost curves, the necessary flow and design data were tabulated for each treatment operation at each plant. The curves were then read to obtain individual treatment operation costs. The results were summed and added to costs for enclosures and segregation. System capital costs (engineering, contractor's fee, contingency) were then applied as were system annual costs (amortization, taxes and insurance, and monitoring) to arrive at the necessary totals for each plant.

Table VIII-10 lists each treatment operation and the corresponding figure or table number where the specific cost correlation is displayed.

Cost Scaling

The third method used to estimate compliance costs was to scale capital and operating costs from similar plants that had been costed by one of the other two methods. As indicated earlier, this technique was utilized for plants for which insufficient information was available to use one of the other two procedures, and for plants whose nonferrous metals forming flow was less than 5 percent of the total plant flow. In the latter case, the impact of the nonferrous metals forming regulation is small enough that a more sophisticated method is unwarranted.

Table VIII-12 lists the number of plants in each subcategory that were addressed by the scaling procedure.

The procedure used for scaling consists of four steps. First, all available information about the plant is summarized. This includes the presence and wastewater flows of each nonferrous metals forming subcategory and other industrial categories, the type of wastewater treatment present at the plant, and the relative production of each subcategory and category at the plant. In the second step, this profile was compared to plants within or outside of the nonferrous metals forming category to identify the most similar facility according to the profile factors given above.

Third, the identified plant's total capital and operating costs were scaled based on the flow and the six-tenths rule for cost estimation:

$$\text{Cost for Subject Plant} = \text{Cost for Analogous Plant} \times \frac{\text{Flow for Subject Plant}}{\text{Flow for Analogous Plant}} \quad 0.6$$

The six-tenths rule has been widely applied for first order approximation of equipment costs.

Finally, the costs of compliance attributable to the nonferrous metals forming regulation are calculated by apportioning the total plant costs on a flow basis.

A greater subjectivity is associated with this procedure than the other two methods due to the inherent uncertainties in selecting and applying analogous plants. However, this procedure yields costs of an acceptable degree of accuracy when examined in light of the availability of information and the minimal overall cost impact of these plants on the forming category.

The calculations and selected analogous plants for each plant subjected to this procedure are contained in the record supporting this rulemaking.

General Cost Assumptions

Regardless of the cost methodology applied, several general cost assumptions were used throughout the category. These include:

- (1) Lime is used for pH adjustment and coagulation in all chemical precipitation and sedimentation systems except for the precious metals subcategory. Caustic is used for precious metals forming wastewater to facilitate precious metals recovery from treatment sludges. These sludges may be recovered by heating in a furnace. If lime is used in chemical precipitation, the calcium ions present in the sludge would cause hot spots in the furnace. This will result in degradation of the furnace lining. Therefore, caustic is used for the precious metals forming subcategory since sodium ions do not cause this condition and fluoride (which requires calcium for removal as calcium fluoride) is not found in significant quantities in precious metals forming wastewater.

- (2) Sludges produced as a result of chemical precipitation and sedimentation which contain excess lime are considered to be nonhazardous waste. Industrial facilities will have to test these sludges. Exceptions are sludges produced by treating uranium forming wastewater, which are considered radioactive wastes.
- (3) Sludges produced as a result of cyanide precipitation are considered to be hazardous.
- (4) Equalization tanks prior to chemical precipitation are not included for plant flows of <100 l/hr.
- (5) For plant flows less than 50 gallons per week, compliance costs are estimated based on treatment or disposal by an off-site source, i.e., contract disposal.
- (6) Enclosure costs are assumed to be zero for all modules except vacuum filters and, in some cases, chemical feed systems.
- (7) Combined treatment of chemical precipitation, chromium reduction (where applicable), and cyanide precipitation (where applicable) is used for flow rates less than 2,200 l/hr. If the costs calculated for combined treatment are less than the costs estimated for each separate treatment operation, the former costs are used. Additional information is provided under COST ESTIMATES FOR INDIVIDUAL TECHNOLOGIES - Combined Treatment, below.
- (8) In cases in which a single plant has wastewater generating processes associated with different nonferrous metals forming subcategories and or other industrial categories, costs are estimated for a single treatment system. In most cases, the combined treatment system costs are then apportioned between subcategories and categories on a flow-weighted basis since hydraulic flow is the primary determinant of equipment size and cost. It is possible, however, for the combined treatment system to include a treatment module that is required by only one of the associated subcategories. In this case, the total costs for that particular module are included in the costs for the subcategory which requires the module. Where the module in question involves flow reduction, the costs are apportioned based on an influent flow-weighted basis. Such cost apportioning is essentially only a bookkeeping exercise to allocate costs; the total costs calculated for the plant remain the same.

Consideration of Existing Treatment

The cost estimates calculated by the model represent "greenfield costs" that do not account for equipment that plants may already have in-place, i.e., these costs include existing treatment equipment. In order to estimate the actual compliance cost that would be incurred by a plant to meet the effluent guidelines, "credit" should be given to account for treatment in place at that plant. This was accomplished by subtracting capital and annual costs of treatment in place from the "greenfield costs" to obtain the actual or required capital and annual costs of compliance.

Existing treatment is considered as such only if the capacity and performance of the existing equipment (measured in terms of estimated ability to meet the proposed effluent limitations) is equivalent to that of the technologies considered by the Agency. The primary source of information regarding existing treatment was data collection portfolios (dcps).

General assumptions applying to all subcategories used for determining treatment in-place qualifications in specific instances include:

- (1) In cases in which existing equipment has adequate performance but insufficient capacity, it is assumed that the plant would comply by either installing additional required capacity to supplement the existing equipment or disregard the existing equipment and install new equipment to treat the entire flow. This selection was based on the lowest total annualized cost.
- (2) When a plant reported processing treatment plant sludges for metal recovery, capital and annual costs for sludge handling (vacuum filtration and contract hauling) are not included in the compliance costs. It is assumed that it is economical for the plant to practice recycle in this case, and therefore, the related costs are considered to be process associated, or a cost of doing business.
- (3) Capital costs for flow reduction (via recycling) were not included in the compliance costs whenever the plant reported recycle of the stream, even if the specific method of recycle was not reported.

- (4) Settling lagoons were assumed to be equivalent to vacuum filtration for dewatering treatment plant sludges. Thus, whenever a plant reported settling lagoons to be currently in use for treatment plant sludges, the capital costs of vacuum filtration were not included. It was assumed that annual vacuum filtration costs were comparable to those for operation of settling lagoons and were used to approximate the annual operating cost for lagoons.

COST ESTIMATES FOR INDIVIDUAL TREATMENT TECHNOLOGIES

Treatment technologies have been selected from among the larger set of available alternatives discussed in Section VII after considering such factors as raw waste characteristics, typical plant characteristics (e.g., location, production schedules, product mix, and land availability), and present treatment practices. Specific rationales for selection is addressed in Sections IX, X, XI, and XII of this document. Cost estimates for each technology addressed in this section include investment costs and annual costs for amortization, operation and maintenance, and energy.

The specific design and cost assumptions for each wastewater treatment module are listed under the subheadings to follow. Costs are presented as a function of influent wastewater flow except where noted in the unit process assumptions.

Costs are presented for the following control and treatment technologies:

- Countercurrent cascade-spray rinsing,
- Cooling towers,
- Holding tanks,
- Flow equalization,
- Cyanide precipitation and gravity settling,
- Chromium reduction,
- Iron co-precipitation,
- Chemical emulsion breaking,
- Ammonia steam stripping,
- Oil-water separation,
- Chemical precipitation and gravity settling,
- Combined treatment,
- Vacuum filtration,
- Multimedia filtration,
- Ion exchange, and
- Contract hauling.

In addition, costs for the following items associated with compliance costs are also discussed:

- Enclosures, and
- Segregation.

Countercurrent Cascade-Spray Rinsing

Countercurrent cascade rinsing is used to reduce water use in rinsing operations. In this process, the cleanest water is used for final rinsing of an item, preceded by rinse stages using water with progressively more contaminants to partially rinse the item. Fresh make-up water is added to the final rinse stage, and contaminated rinse water is discharged from the initial rinse stage. The make-up water for all but the final rinse stage is from the following stage. The addition of overhead sprays to the rinsing process also increases rinsing efficiency. Therefore, countercurrent cascade rinsing with sprays was costed when appropriate as a flow reduction technology for rinse operations.

The costs for countercurrent cascade-spray rinsing apply to a two-stage rinse system, each consisting of the following equipment:

- o Two fiberglass rectangular tanks (for existing sources, costs include only one additional tank since the first tank was assumed to be in place).
- o One spray rinsing system if not in place,
 - stainless steel spray nozzles
 - valves
 - Teflon-lined piping system
 - conductivity meter
 - strainer
 - splash guard.
- o PVC spargers (air diffuser) for agitation,
 - one sparger/1.5 feet of tank length
 - 4 cubic feet of air/min/sparger
 - 8 hours installation
 - 20 feet of interconnecting piping.
- o One blower (including motor) for supplying air to the sparger.

Retrofit capital costs are estimated at 15 percent of the installed equipment cost.

Information reported in dcps was used to estimate the volume of countercurrent rinse tanks. If no information was available, tank volume was assumed to be 1,000 gallons. When it was determined from a plant's dcp that two-stage countercurrent cascade rinsing could be achieved by converting two existing adjacent rinse tanks, only piping, pump, and spray rinsing costs were accounted for. A constant value of \$1,000 was estimated for the piping costs.

Maintenance materials are estimated at 2 percent of purchased equipment cost, and maintenance labor is estimated at 5 percent of the operating hours.

Capital costs for the spray rinsing system are presented in Figure VIII-4, and annual costs as an equation in Table VIII-11. Capital and annual costs may be determined for rectangular fiberglass tanks with spargers and interconnecting piping in Figure VIII-5. Capital and annual costs for pumps may be found in Figure VIII-6.

Cooling Towers

Cooling towers are used to reduce discharge flows by recycling cooling water waste streams. Holding tanks are used to recycle flows less than 3,400 liters per hour (15 gpm). This flow represents the effective minimum cooling tower capacity generally available.

The cooling tower capacity is based on the amount of heat removed, which takes into account both the design flow and the temperature decrease needed across the cooling tower. The influent flow to the cooling tower and the recycle rate are based on the assumptions given in Table VIII-13, page . It should be noted that for BAT a cooling tower is not included for cases in which the actual flow is less than the reduced regulatory flow (BAT flow) since flow reduction is not required.

The temperature decrease is calculated as the difference between the hot water (inlet) and cold water (outlet) temperatures. The cold water temperature was assumed to be 20C (85F) and an average value calculated from sampling data is used as the hot water temperature for a particular waste stream. When such data were unavailable, or resulted in a temperature less than 35C (95F), a value of 35C (95F) was assumed, resulting in a cooling requirement for a 6C (10F) temperature drop. The other two design parameters, namely the wet bulb temperature (i.e., ambient temperature at 100 percent relative humidity) and the approach (the difference between the outlet water temperature and the wet bulb temperature), were assumed to be constant at 25C (77F) and 4C (8F), respectively.

For flow rates above 3,400 l/hr, a cooling tower is assumed. The cooling tower is sized by calculating the required capacity in evaporative tons. Cost data were gathered for cooling towers up to 700 evaporative tons.

The capital costs of cooling tower systems include the following equipment:

- Cooling tower (crossflow, mechanically-induced) and typical accessories;
- Piping and valves (305 meters (1,000 ft.), carbon steel);

- Cold water storage tank (1-hour retention time);
- Recirculation pump, centrifugal; and
- Chemical treatment system (for pH, slime and corrosion control).

For heat removal requirements exceeding 700 evaporative tons, multiple cooling towers are assumed.

The direct capital costs include purchased equipment cost, delivery, and installation. Installation costs for cooling towers are assumed to be 200 percent of the cooling tower cost based on information supplied by vendors.

Direct annual costs include raw chemicals for water treatment and fan energy requirements. Maintenance and operating labor was assumed to be constant at 60 hours per year. The water treatment chemical cost is based on a rate of \$220/1,000 lph (\$5/gpm) of recirculated water.

For small recirculating flows (less than 15 gpm), holding tanks were used for recycling cooling water. A holding tank system consists of a steel tank, 61 meters (200 feet) of piping, and a recirculation pump. The capacity of the holding tank is based on the cooling requirements of the water to be cooled. Calculation of the tank volume is based on a surface area requirement of 0.025 m²/lph (60 ft²/gpm) of recirculated flow and constant relative tank dimensions.

Capital costs for the holding tank system include purchased equipment cost, delivery and installation. The annual costs are attributable to the operation of the pump only (i.e., annual costs for tank and piping are assumed to be negligible).

Capital and annual costs for cooling towers and tanks are presented in Figure VIII-7.

Holding Tanks-Recycle

A holding tank is used to recycle water back to a process. Holding tanks are usually used when the recycled water need not be cooled. The equipment used to determine capital costs are a tank, pump, and recycle piping. Fiberglass tanks were used for capacities of 24,000 gallons or less; steel tanks for larger capacities. Annual costs are associated only with the pump. The tank capital cost is estimated on the basis of required volume. Required tank volume is calculated on the basis of influent flow rate, 20 percent excess capacity, and four-hour retention time. The influent flow and the degree of recycle were derived from the assumptions outlined in Table VIII-13.

Cost curves for direct capital and annual costs are presented in Figure VIII-8.

Flow Equalization

Flow equalization is accomplished through equalization tanks which are sized based on a retention time of 8 or 16 hours and an excess capacity factor of 1.2. Fiberglass tanks were used for capacities of 24,000 gallons or less; steel tanks for larger capacities. A retention time of 16 hours was assumed only when the equalization tank preceded a chemical precipitation system with "low flow" mode, and the operating hours were greater than or equal to 16 hours per day. In this case, the additional retention time is required to hold wastewater during batch treatment, since treatment is assumed to require 16 hours and only one reaction tank is included in the "low flow" batch mode. Cost data were available for steel equalization tank up to a capacity of 1,893,000 liters (500,000 gallons); multiple units were required for volumes greater than 1,893,000 liters (500,000 gallons). The tanks are fitted with agitators with a horsepower requirement of 0.006 kW/1,000 liters (0.03 hp/1,000 gallons) of capacity to prevent sedimentation. An influent transfer pump is also included in the equalization system.

Annual costs include electricity costs for the agitator and pump and 5 percent of the installed tank cost for maintenance.

Cost curves for capital and annual costs are presented in Figure VIII-9, for equalization at 8 hours and 16 hours retention time.

Cyanide Precipitation and Gravity Settling

Cyanide precipitation is a two-stage process to remove complexed and uncomplexed cyanide as a precipitate. In the first step, the wastewater is contacted with an excess of $\text{FeSO}_4 \cdot 7\text{H}_2\text{O}$ at pH 9.0 to ensure that all cyanide is converted to the complexed form:

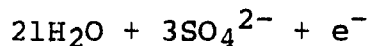
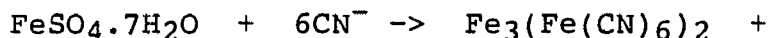

The hexacyanoferrate is then routed to the second stage, where additional $\text{FeSO}_4 \cdot 7\text{H}_2\text{O}$ and acid are added. In this stage, the pH is lowered to 4.0 or less, causing the precipitation of $\text{Fe}_3(\text{Fe}(\text{CN})_6)_2$ (Turnbull's blue) and its analogues:

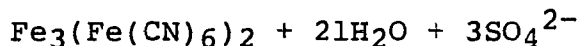
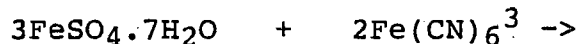

The blue precipitate is settled and the overflow is discharged for further treatment.

Since the complexation step adjusts the pH to 9, metal hydroxides will precipitate. These hydroxides may either be settled and

removed at pH 9 or resolubilized at pH 4 in the final precipitation step and removed later in a downstream chemical precipitation unit. Advantages of preliminary removal of the metal hydroxides include reduced acid requirements in the final precipitation step, since the metals will resolubilize when the pH is adjusted to 4. However, the hydroxide sludge may be classified as hazardous due to the presence of cyanide. In addition, the continuous mode operation requires an additional clarifier between the complexation and precipitation step. These additional costs make the settling of metal hydroxides economically unattractive in the continuous mode. However, the batch mode requires no extra equipment. Consequently, metal hydroxide sludge removal in this case is desirable before the precipitation step. Therefore, the batch cyanide precipitation step settles two sludges: metal hydroxide sludge (at pH 9) and cyanide sludge (at pH 4).

Costs were estimated for both batch and continuous systems with the operating mode selected on a least cost basis. The equipment and assumptions used in each mode are detailed below.

Costs for the complexation step in the continuous mode are based on the following:

(1) Ferrous sulfate feed system

- ferrous sulfate steel storage hoppers with dust collectors (largest hopper size is 170 m³ (6,000 ft³); 15 days storage)
- enclosure for storage tanks
- volumetric feeders (small installations)
- mechanical weigh belt feeders (large installations)
- dissolving tanks (5-minute detention time, 6 percent solution) - dual-head diaphragm metering pumps
- instrumentation and controls

(2) Lime feed system

- hydrated lime
- feeder
- slurry mix tank (5-minute retention time)
- feed pump
- instrumentation (pH control)

(3) H₂SO₄ feed system (used when influent pH is >9)

- 93 percent H₂SO₄ delivered in bulk or in drums
- acid storage tank (15 days retention) when delivered in bulk
- metering pump (standby provided)
- pipe and valves
- instrumentation and controls

- (4) Reaction tank and agitator (fiberglass, 60-minute retention time, 20 percent excess capacity, agitator mount, concrete slab)
- (5) Effluent transfer pump.

Costs for the second step (precipitation) in the continuous mode are based on the following equipment:

- (1) FeSO_4 feed system - as above
- (2) H_2SO_4 feed system - as above
- (3) Polymer feed system
 - storage hopper
 - chemical mix tank with agitator
 - chemical metering pump
- (4) Reaction tank with agitator (fiberglass, 30-minute retention time, 20 percent excess capacity, agitator mount, concrete slab)
- (5) Clarifier
 - sized based on 709 lph/m^2 (17.4 gph/ft^2), 3 percent solids in underflow
 - steel or concrete, above ground - support structure, sludge scraper, and other internals
 - center feed
- (6) Effluent transfer pump
- (7) Sludge transfer pump.

Operation and maintenance costs for continuous mode cyanide precipitation include labor requirements to operate and maintain the system, electric power for mixers, pumps, clarifier and controls, and treatment chemicals. Electrical requirements are also included for the chemical storage enclosures for lighting and ventilation and in the case of caustic storage, heating. The following assumptions are used in establishing O&M costs for the complexation step in the continuous mode:

- (1) Ferrous sulfate feed system
 - stoichiometry of 1 mole $\text{FeSO}_4 \cdot 7\text{H}_2\text{O}$ to 6 moles CN^-
 - 1.5 times stoichiometric dosage to drive reaction to completion
 - operating labor at 10 min/feeder/shift
 - maintenance labor at 8 hrs/yr for liquid metering pumps
 - power based on agitators, metering pumps
 - maintenance materials at 3 percent of capital cost

- chemical cost (sewage grade) at \$0.1268 per kg (\$0.0575 per lb)
- (2) Lime feed system
- dosage based on pH and metals content to raise pH to 9
 - operating and maintenance labor requirements are based on 20 min/day; in addition, 8 hrs/7,260 kg (8 hrs/16,000 lbs) are assumed for delivery of hydrated lime
 - maintenance materials cost is estimated as 3 percent of the purchased equipment cost
 - chemical cost of lime is based on \$0.0474/kg (\$0.0215 per lb) for hydrated lime delivered in bags
- (3) Acid feed system (if required)
- dosage based on pH and metals to bring pH to 9
 - labor unloading - 0.25 hr/drum acid
 - labor operation - 15 min/day
 - annual maintenance - 8 hrs
 - power (includes metering pump)
 - maintenance materials - 3 percent of capital cost
 - chemical cost at \$0.082 per kg (\$0.037 per lb)
- (4) Reaction tank with agitator
- maintenance materials
 - tank: 2 percent of tank capital cost
 - pump: 5 percent of pump capital cost
 - power based on agitator (70 percent efficiency) at 0.099 kW/1,000 liters (0.5 hp/1,000 gallons) of tank volume
- (5) Pump
- operating labor at 0.04 hr/operating day
 - maintenance labor at 0.005 hr/operating hour
 - maintenance materials at 5 percent of capital cost
 - power based on pump hp.

The following assumptions were used for the continuous mode precipitation step:

- (1) Ferrous sulfate feed system
- stoichiometric dosage based on 3 moles $\text{FeSO}_4 \cdot 7\text{H}_2\text{O}$ to 2 moles of iron-complexed cyanide ($\text{Fe}(\text{CN})_6^-$)
 - total dosage is 10 times stoichiometric dosage based on data from an Agency treatability study
 - other assumptions as above

- (2) H₂SO₄ feed system
 - dosage based on pH adjustment to 4 and resolubilization of the metal hydroxides from the complexation step
 - other assumptions as above
- (3) Polymer feed system
 - 2 mg/l dosage
 - operation labor at 134 hrs/yr, maintenance labor at 32 hrs/yr
 - maintenance materials at 3 percent of the capital cost
 - power at 17,300 kW/yr
 - chemical cost at \$4.96/kg (\$2.25/lb)
- (4) Reaction tank with agitator
 - see assumptions above
- (5) Clarifier
 - maintenance materials range from 0.8 percent to 2 percent as a function of increasing size
 - labor - 150 to 500 hrs/yr (depending on size)
 - power - based on horsepower requirements for sludge pumping and sludge scraper drive unit
- (6) Effluent transfer pump
 - see assumptions above
- (7) Sludge pump
 - sized on underflow from clarifier
 - operation and maintenance labor varies with flow rate
 - maintenance materials - varies from 7 percent to 10 percent of capital cost depending on flow rate.

The batch mode cyanide precipitation step accomplishes both complexation and precipitation in the same vessel. Costs for batch mode cyanide complexation and precipitation are based on the following equipment:

- (1) Ferrous sulfate addition
 - from bags
 - added manually to reaction tank

- (2) Lime addition
 - from bags
 - added manually to reaction tank
- (3) H_2SO_4 addition
 - from 208 liter (55 gallon) drums
 - stainless steel valve to control flow
- (4) Reaction tank and agitator (fiberglass, 8.5 hours minimum retention time, 20 percent excess capacity, agitator mount, concrete slab)
- (5) Effluent transfer pump
- (6) Sludge pump.

Operation and maintenance costs for batch mode cyanide complexation and precipitation include costs for the labor required to operate and maintain the equipment; electrical power for agitators, pumps, and controls; and chemicals. The assumptions used in estimating costs are as follows:

- (1) Ferrous sulfate addition
 - stoichiometric dosage
 - complexation: 1 mole $FeSO_4 \cdot 7H_2O$ per 6 moles CN^-
 - precipitation: 3 moles $FeSO_4 \cdot 7H_2O$ per 2 moles of the iron cyanide complex $(Fe(CN)_6)_2$
 - actual dosage in excess of stoichiometric
 - complexation: 1.5 times stoichiometric dosage added
 - precipitation: 10 times stoichiometric dosage added
 - operating labor at 0.25 hr/batch
 - chemical cost (sewage grade) at \$0.1268/kg (\$0.0575/lb)
 - no maintenance labor or materials, or power costs
- (2) Lime addition
 - dosage based on pH and metals content to raise pH to 9
 - operating labor at 0.25 hr/batch
 - chemical cost at \$0.0474/kg (\$0.0215/lb)
 - no maintenance labor or materials, or power costs
- (3) H_2SO_4 addition
 - dosage based on pH and metals content to lower pH to 9 (for complexation if required) and/or to lower pH to 4 (for precipitation)

- operating labor at 0.25 hr/batch
 - chemical cost at \$0.082/kg (\$0.037/lb)
 - no maintenance labor or materials, or power costs
- (4) Reaction tank with agitator
- maintenance materials
 - tank: 2 percent of tank capital cost
 - pump: 5 percent of pump capital cost
 - power based on agitator (70 percent efficiency) at 0.099 kW/1,000 liters (0.5 hp/1,000 gallons) of tank volume
- (5) Effluent transfer pump
- operating labor at 0.04 hr/operating day
 - maintenance labor at 0.005 hr/operating day
 - maintenance materials at 5 percent of capital cost
 - power based on pump hp
- (6) Sludge pump
- operation and maintenance costs vary with flow rate
 - maintenance materials costs vary from 7 to 10 percent of capital cost depending on flow rate.

Capital and annual costs for continuous and batch mode cyanide precipitation are presented in Figure VIII-10.

At plants where the total flow requiring cyanide treatment is low, cyanide precipitation and settling may be accomplished in the same unit as chemical precipitation and settling. This is called combined treatment and is discussed later in this section.

Chromium Reduction

Chromium reduction refers to the reduction of hexavalent chromium to the trivalent form. Chromium in the hexavalent state will not precipitate as a hydroxide; it must first be reduced to trivalent chromium. For large flows (greater than 2,000 l/hr) which undergo continuous treatment, the waste stream is treated by addition of acid (to lower pH to 2.5) and gaseous sulfur dioxide (SO₂) dissolved in water in an agitated reaction vessel. The SO₂ is oxidized to sulfate (SO₄) while it reduces the chromium. For smaller flows (less than 2,000 l/hr), for which batch treatment is more appropriate, the waste stream is treated by manual addition of sodium metabisulfite in the same reaction vessel used for chemical precipitation. The chemistry of this operation is similar to that for SO₂ addition. This is referred to as combined treatment, and is discussed more fully later in this section.

The equipment required for the continuous stream includes a SO₂ feed system (sulfonator), a H₂SO₄ feed system, an acid resistant reactor vessel and agitator, and a stainless steel

pump. The reaction pH is 2.5 and the SO₂ dosage is a function of the influent loading of hexavalent chromium. A conventional sulfonator is used to meter SO₂ to the reaction vessel. The mixer velocity gradient is 100/sec.

Annual costs are as follows:

(1) SO₂ feed system

- SO₂ cost at \$0.55/kg (\$0.25/lb)
- operation and maintenance labor requirements vary from 437 hrs/yr at 4.5 kg SO₂/day (10 lbs SO₂/day) to 5,440 hrs/yr at 4,540 kg SO₂/day (10,000 lbs SO₂/day)
- energy requirements vary from 570 kW/yr at 4.5 kg SO₂/day (10 lbs SO₂/day) to 31,000 kW/yr at 4,540 kg SO₂/day (10,000 lbs SO₂/day)

(2) H₂SO₄ feed system

- operating and maintenance labor at 72 hrs/yr at 37.8 lpd (10 gpd) of 93 percent H₂SO₄ to 200 hrs/yr at 3,780 lpd (1,000 gpd), of 93 percent H₂SO₄
- maintenance materials at 3 percent of the equipment cost
- energy requirements for metering pump and storage heating and lighting

(3) Reactor vessel and agitator

- operation and maintenance labor at 120 hrs/yr
- electrical requirements for agitator.

For batch treatment of hexavalent chromium with sodium metabisulfite, no equipment in addition to that required for chemical precipitation is assumed to be necessary. Annual costs are based on 1/2 hour of labor per batch for chemical addition and testing.

Figure VIII-11 presents capital and annual costs for a continuous chromium reduction system and capital costs for the batch system. Annual costs for the batch system are presented in Table VIII-11.

Iron Co-Precipitation

Molybdenum is effectively precipitated by addition of high excesses of iron salts at low pH. Although the precipitation chemistry and precise iron-molybdenum compounds formed are not well understood, complexation and physical adsorption onto settling iron hydroxide floc have both been postulated as mechanisms for molybdenum removal. This technology is described in more detail in Section VII.

The necessary iron salt dosage has been determined empirically as approximately a 10:1 weight ratio of iron to the summed mass of

molybdenum To alleviate scaling problems, FeCl_3 is selected over $\text{Fe}_2(\text{SO}_4)_3$ as the iron source. The pH for optimum precipitation is 4.0. Hydrochloric acid is added as the acid source. Removal of the insoluble precipitates is accomplished during chemical precipitation and sedimentation.

Capital and operating costs have been estimated for both continuous, batch and low flow operating modes. However, for the nonferrous metals forming industry, all plants requiring iron coprecipitation generated flows in the batch and low flow treatment ranges. Assumptions for cost estimation of the batch FeCl_3 feed system are as follows:

Capital

- o Flow between 100 l/hr and 10,500 l/hr
- o Influent molybdenum concentration is assumed as 150 mg/l
- o FeCl_3 (40 weight percent solution) is added at 10:1 iron to molybdenum ratio
- o FeCl_3 storage hopper: 2-week supply
- o Mix tank of 8 hrs retention, 20 percent excess, 50 gal minimum
- o Agitator at 0.5 hp/1,000 gal, 0.25 hp minimum
- o Pump at 3 gpm feed

Annual

- o Operating labor at 0.75 hour/batch
- o Maintenance labor at 1 hour/week
- o Batch is 8 hrs of flow
- o FeCl_3 (sewage grade) at \$174/ton

Assumptions for the low flow FeCl_3 feed system include:

Capital

- o Flow less than 2,200 l/hr
- o Manual addition of FeCl_3 from bags (hopper included at \$2,360 for flows greater than 500 l/hr)
- o 10,000 gallons of wastewater accumulated prior to treatment

Annual

- o 10,000 gallons of wastewater accumulated prior to treatment

- o Operating labor and maintenance labor are calculated by 0.25 hr/batch + 0.0025 hr/lb FeCl₃
- o FeCl₃ cost is \$0.21/lb for flow < 500 l/hr; \$0.087/lb for flows > 500 l/hr

Assumptions for the batch and low flow pH adjustment system are as follows:

Capital

- o Manual addition from drum
- o \$250 capital cost for acid valve
- o Dosage based on 100 mg CaCO₃/l alkalinity

Annual

- o 0.25 hr/batch for operation labor
- o 1 hr/7 batches for maintenance labor
- o HCl (22° Baume) is \$85/ton

The sludge generation from iron co-precipitation is 0.05 l sludge/l of influent flow from molybdenum-containing streams (0.0075 l sludge/l influent for dewatered sludge). This sludge is in addition to the sludge ratios presented earlier.

Capital costs for iron co-precipitation are presented in Figure VIII-12, while annual costs are presented in Figure VIII-13.

Chemical Emulsion Breaking

Chemical emulsion breaking involves the separation of relatively stable oil-water mixtures by chemical addition. Alum, polymer, and sulfuric acid are commonly used to destabilize oil-water mixtures. In the determination of capital and annual costs based on continuous operation, 400 mg/l of alum and 2 mg/l of polymer are added to waste streams containing emulsified oil. In the continuous system, no sulfuric acid is required. The equipment included in the capital and annual costs for continuous chemical emulsion breaking are as follows:

- (1) Alum and polymer feed systems
 - storage units
 - dilution tanks
 - conveyors and chemical feed lines
 - chemical feed pumps
- (2) Rapid mix tank (retention time of 15 minutes; mixer velocity gradient is 300/sec, 20 percent excess capacity)
- (3) Flocculation tank (retention time of 45 minutes; mixer velocity gradient is 100/sec, 20 percent excess capacity)

(4) Pump.

Following the flocculation tank, the destabilized oil-water mixture is routed to oil skimming.

In the determination of capital and annual costs based on batch operation, sulfuric acid is added to waste streams containing emulsified oil until a pH of 3 is reached. No alum or polymer is required. The following equipment is included in the determination of capital and annual costs based on batch operation:

- (1) Sulfuric acid feed systems
 - storage tanks or drums
 - chemical feed lines
 - chemical feed pumps
- (2) Two tanks equipped with agitators (retention time of 8 hrs, mixer velocity gradient is 300/sec, 20 percent excess capacity)
- (3) Two belt oil skimmers
- (4) Two waste oil pumps
- (5) Two effluent water pumps
- (6) One waste oil storage tank (sized to retain the waste oil from eight batches, 20 percent excess capacity).

The capital and annual costs for continuous and batch chemical emulsion breaking were determined by summing the costs from the above equipment. Alum, polymer, and sulfuric acid costs were assumed to be \$0.257 per kg (\$0.118 per pound), \$4.95 per kg (\$2.25 per pound), and \$0.08 per kg of 93 percent acid (\$0.037 per pound of 93 percent acid), respectively.

Operation and maintenance and energy costs for the different types of equipment which comprise the batch and continuous systems were drawn from various literature sources and are included in the annual costs.

The cutoff flow for determining the operation mode (batch or continuous) is 1,000 liters per hour (264 gal/hr), above which the continuous system is costed; at lower flows, the batch system is costed.

For annual influent flows to the chemical emulsion breaking system of 92,100 liters/year (24,000 gallons/year) or less, it is more economical to directly contract haul rather than treat the waste stream. The breakpoint flow is based on a total annualized cost comparison and a contract hauling rate of \$0.40/gallon (no credit was given for oil resale).

Capital and annual costs for chemical emulsion breaking are presented in Figure VIII-14.

Ammonia Steam Stripping

Ammonia removal using steam is a proven technology that is in use in many industries. Ammonia is more volatile than water and may be removed using steam to raise the temperature and preferentially evaporate the ammonia. This process is most economically done in a plate or packed tower, where the method of contacting the liquid and vapor phases reduces the steam requirement.

The pH of the influent wastewater is raised to approximately 12 by the addition of lime to convert almost all of the ammonia present to molecular ammonia (NH_3). The water is preheated before it is sent to the column. This process takes place by indirectly contacting the influent with the column effluent and with the gaseous product via heat exchangers. The water enters the top of the column and travels downward. The steam is injected at the bottom and rises through the column, contacting the water in a countercurrent fashion. The source of the steam may be either boiled wastewater or another steam generation system, such as the plant boiler system.

The presence of solids in the wastewater, both those present in the influent and those which may be generated by adjusting the pH (such as metal hydroxides), necessitates periodic cleaning of the column. This requires an acid cleaning system and a surge tank to hold wastewater while the column is being cleaned. The column is assumed to require cleaning approximately once per week based on the demonstrated long-term cleaning requirements of an ammonia stripping facility. The volume of cleaning solution used per cleaning operation is assumed to be equal to the total volume of the empty column (i.e., without packing).

For the estimation of capital and annual costs, the following pieces of equipment were included in the design of the steam stripper:

- (1) Packed tower
 - 3-inch Rashig rings
 - hydraulic loading rate = 2 gpm/ft²
 - height equivalent to a theoretical plate = 3 ft
- (2) pH adjustment system
 - lime feed system (continuous) - see chemical precipitation section for discussion
 - rapid mix tank, fiberglass (5-minute retention time)
 - agitator (velocity gradient is 300 ft/sec/ft)
 - control system
 - pump
- (3) Heat exchangers (stainless steel)

- (4) Reboiler (gas-fired)
- (5) Acid cleaning system
 - batch tank, fiberglass
 - agitator (velocity gradient is 60/sec)
 - metering pump
- (6) Surge tank (8-hour retention time).

The direct capital cost of the lime feed system was based on the chemical feed rate as noted in the discussion on chemical precipitation. Sulfuric acid used in the acid cleaning system was assumed to be added manually, requiring no special equipment. Other equipment costs were direct or indirect functions of the influent flow rate. Direct annual costs include operation and maintenance labor for the lime feed system, heat exchangers and reboiler; the cost of lime and sulfuric acid, maintenance materials, energy costs required to run the agitators and pumps; and natural gas costs to operate the reboiler. The cost of natural gas is \$6.70/1,000 scf. The total direct capital and annual costs are presented in Figure VIII-15.

Oil-Water Separation

Oil skimming costs apply to the removal of free (non-emulsified) oil using either a coalescent plate oil-water separator or a belt skimmer located on the equalization tank. The latter is applicable to low oil removal rates (less than 189 liters per day) whereas the coalescent plate separator is used for oil removal rates greater than 189 liters/day (50 gpd).

Although the required coalescent plate separator capacity is dependent on many factors, the sizing was based primarily on the influent wastewater flow rate, with the following design values assumed for the remaining parameters of importance:

Parameter	Design Value
Specific gravity of oil	0.85
Operating temperature (°F)	68
Effluent oil concentration (mg/l)	10.0

Extreme operating conditions, such as influent oil concentrations greater than 30,000 mg/l, or temperatures much lower than 20C (68F) were accounted for in the sizing of the separator. Additional capacity for such extreme conditions was provided using correlations developed from actual oil separator performance data.

The capital and annual costs of oil-water separation include the following equipment:

- Coalescent plate separator with automatic shutoff valve and level sensor
- Oily waste storage tanks (2-week retention time)
- Oily waste discharge pump
- Effluent discharge pump

Influent flow rates up to 159,100 l/hr (700 gpm) are treated in a single unit; flows greater than this require multiple units.

The direct annual costs for oil-water separation include the cost of operating and maintenance labor and replacement parts. Annual costs for the coalescent plate separators alone are minimal and involve only periodic cleaning and replacement of the plates.

If the amount of oil discharged is 189 liters/day (50 gpd) or less, it is more economical to use a belt skimmer rather than a coalescent plate separator. This belt skimmer may be attached to the equalization basin which is usually necessary to equalize flow surges. The belt skimmer-equalization basin configuration is assumed to achieve 10 mg/l oil in the effluent.

The equipment included in the belt oil skimmer and associated design parameters and assumptions are presented below.

- (1) Belt oil skimmer
 - 12-inch width
 - 6-foot length
- (2) Oily waste storage tank
 - 2-week storage
 - fiberglass

Capital costs for belt skimmers were obtained from published vendor quotes. Annual costs were estimated from the energy and operation and maintenance requirements. Energy requirements are calculated from the skimmer motor horsepower. Operating labor is assumed constant at 26 hours per year. Maintenance labor is assumed to require 24 labor hours per year and belt replacement once a year.

Capital and annual costs for oil-water separation are \$2,600 and \$1,300, respectively, based on these assumptions.

Chemical Precipitation and Gravity Settling

Chemical precipitation using lime or caustic followed by gravity settling is a fundamental technology for metals removal. In practice, quicklime (CaO), hydrated lime (Ca(OH)₂), or caustic (NaOH) can be used to precipitate toxic and other metals. Where lime is selected, hydrated lime is generally more economical for low lime requirements since the use of slakers, which are necessary for quicklime usage, is practical only for large volume applications of lime (greater than 50 lbs/hr). The

chemical precipitant used for compliance costs estimation depends on a variety of factors and the subcategory being considered.

Lime or caustic is used to adjust the pH of the influent waste stream to a value of approximately 9, at which optimum overall precipitation of the metals as metal hydroxides is assumed to occur. The chemical precipitant dosage is calculated as a theoretical stoichiometric requirement based on the pH and the influent metals concentrations. In addition, particular waste streams may contain significant amounts of fluoride. The fluoride will form calcium fluoride (CaF_2) when combined with free calcium ions which are present if lime is used as the chemical precipitant. The additional sludge due to calcium fluoride formation is included in the sludge generation calculations. In cases where the calcium consumed by calcium fluoride formation exceeds the calcium level resulting from dosing for pH adjustment and metal hydroxide formation, the additional lime needed to consume the remaining fluoride is included in the total theoretical dosage calculation. The total chemical dosage requirement is obtained by assuming an excess of 10 percent of the theoretical dosage. The effluent concentrations are generally based on the Agency's combined metals data base treatment effectiveness values for chemical precipitation technology described in Section VII.

The costs of chemical precipitation and gravity settling are based on one of three operating modes, depending on the influent flow: continuous, "normal" batch, or "low flow" batch. The use of a particular mode for cost estimation purposes is determined on a least cost (total annualized) basis. The economic break-point between continuous and normal batch was estimated to be 10,600 l/hr (46.7 gpm). Below 2,200 l/hr, it was found that the low flow batch was the most economical. The direct capital and annual costs are presented in Figure VIII-16 for all three operating modes.

Continuous Mode. For continuous operation, the following equipment is included in the determination of capital and annual costs:

- (1) Chemical precipitant feed system (continuous)
 - lime
 - bags (for hydrated lime) or storage units (30-day storage capacity) for quicklime
 - slurry mix tank (5-minute retention time) or slaker
 - feed pumps (for hydrated lime slurry) or gravity feed (for quicklime slurry)
 - instrumentation (pH control)
 - caustic
 - day tanks (2) with mixers and feeders for feed rates less than 200 lbs/day; fiberglass tank with 15-day storage capacity otherwise
 - chemical metering pumps

- pipe and valves
- instrumentation (pH control)

(2) Polymer feed system

- storage hopper
- chemical mix tank with agitator
- chemical metering pump

(3) Reaction system

- rapid mix tank, fiberglass (5-minute retention time)
- agitator (velocity gradient is 300 ft/sec/ft)
- instrumentation and control

(4) Gravity settling system

- clarifier, circular, steel (overflow rate is 560 gpd/ft²; underflow solids is 3 percent)

(5) Sludge pump

Ten percent of the clarifier underflow stream is recycled to the pH adjustment tank to serve as seed material for the incoming waste stream.

The direct capital costs of the chemical precipitant and polymer feed are based on the respective feed rates (dry lbs/hr), which are dependent on the influent waste stream characteristics. The flexibility of this feature (i.e., costs are independent of other module components) was previously noted in the description of the cost estimation model. The remaining equipment costs (e.g., for tanks, agitators, pumps) were developed as a function of the influent flow (either directly or indirectly, when coupled with the design assumptions).

Direct annual costs for the continuous system are based on the following assumptions:

(1) Lime feed system

- operating and maintenance labor requirements are based on 3 hrs/day for the quicklime feed system and 20 min/day for the hydrated lime feed system; in addition, 5 hrs/50,000 lbs are required for bulk delivery of quicklime and 8 hrs/16,000 lbs are assumed for delivery of hydrated lime
- maintenance materials cost is estimated as 3 percent of the purchased equipment cost
- chemical cost of lime is based on \$47.40/kkg (\$43.00/ton) for hydrated lime delivered in bags and \$34.50/kkg (\$31.30/ton) for quicklime delivered on a bulk basis (these costs were obtained from the Chemical Marketing Reporter)

(2) Caustic feed system

- labor for unloading of dry NaOH requires 8 hours/16,000 lbs delivered; liquid 50 percent NaOH requires 5 hours/50,000 lbs
- operating labor for dry NaOH feeders is 10 min/day/feeder
- operating labor for metering pump is 15 min/day
- maintenance materials cost is assumed to be 3 percent of the purchased equipment cost
- maintenance labor requires 8 hours/year
- energy cost is based on the horsepower requirements for the feed pumps and mixers; energy requirements generally represent less than 5 percent of the total annual costs for the caustic feed system
- chemical cost is \$0.183 per lb

(3) Polymer feed system

- polymer requirements are based on a dosage of 2 mg/l
- the operating labor is assumed to be 134 hrs/yr, which includes delivery and solution preparation requirements; maintenance labor is estimated at 32 hrs/yr
- energy costs for the feed pump and mixer are based on 17,300 kW-hr/yr
- chemical cost for polymer is based on \$5.00/kkg (\$2.25/lb)

(4) Reaction system

- operating and maintenance labor requirements are 120 hrs/yr
- pumps are assumed to require 0.005 hrs of maintenance/operating hr (for flows less than 100 gpm) or 0.01 hrs/operating hr (flows greater than 100 gpm), in addition to 0.05 hrs/operating day for pump operation
- maintenance materials costs are estimated as 5 percent of the purchased equipment cost
- energy costs are based on the power requirements for the pump (function of flow) and agitator (0.06 hp/1,000 gal); an agitator efficiency of 70 percent was assumed

(5) Gravity settling system

- annual operating and maintenance labor requirements range from 150 hrs for the minimum size clarifier (300 ft²) to 500 hrs for a clarifier of 30,000 ft²; in addition, labor hours for operation and maintenance of the sludge pumps were assumed to range from 55 to 420 hrs/yr, depending on the pump capacity (10 to 1,500 gpm)

- maintenance material costs are estimated as 3 percent of the purchased equipment cost
- energy costs are based on power requirements for the sludge pump and rake mechanism.

Normal Batch Mode. The normal batch treatment system, which is used for flows between 2,200 and 10,600 l/yr, consists of the following equipment:

(1) Chemical precipitant feed system

- lime (batch)
 - slurry tank (5-minute retention time)
 - agitator
 - feed pump
- caustic (batch)
 - fiberglass tank (1-week storage)
 - chemical metering pump

(2) Polymer feed system (batch)

- chemical mix tank (5-day retention time)
- agitator
- chemical metering pump

(3) Reaction system

- reaction tanks (minimum of 2) (8-hour retention time each)
- agitators (2) (velocity gradient is 300 ft/sec/ft)
- pH control system

The reaction tanks used for pH adjustment are sized to hold the wastewater volume accumulated for one batch period (assumed to be 8 hours). The tanks are arranged in a parallel setup to allow treatment in one tank while wastewater is accumulated in the other tank. A separate gravity settler is not necessary since settling can occur in the reaction tank after precipitation has taken place. The settled sludge is then pumped to the dewatering stage if necessary.

Direct annual costs for the normal batch treatment system are based on the following assumptions:

(1) Lime feed system (batch)

- operating labor requirements range from 15 to 60 min/batch, depending on the feed rate (5 to 1,000 lbs of hydrated lime/batch)
- maintenance labor is assumed to be constant at 52 hrs/yr (1 hr/week)
- energy costs for the agitator and feed pump are assumed to be negligible
- chemical costs are based on the use of hydrated lime (see continuous feed system assumptions)

(2) Caustic feed system (batch)

- operating labor requirements are based on 30 min/metering pump/shift
- maintenance labor requirements are 16 hrs/metering pump/year
- energy costs are assumed to be negligible
- chemical costs are based on the use of 50 percent liquid caustic solution (see continuous feed system)

(3) Polymer feed system (batch)

- polymer requirements are based on a dosage of 2 mg/l
- operating and maintenance labor are assumed to require 50 hrs/year
- chemical cost for polymer is based on \$5.00/kkg (\$2.25/lb)

(4) Reaction system

- required operating labor is assumed to be 1 hr/batch (for pH control, sampling, valve operation, etc.)
- maintenance labor requirements are 52 hrs/yr
- energy costs are based on power requirements for operation of the sludge pump and agitators.

Low-Flow Batch Mode. For small influent flows (less than 2,200 l/hr), it is more economical on a total annualized cost basis to select the "low flow" batch treatment system. The lower flows allow an assumption of up to five days for the batch duration, or holding time, as opposed to eight hours for the normal batch system. However, whenever the total batch volume (based on a five-day holding time) exceeds 10,000 gallons, which is the maximum single batch tank capacity, the holding time is decreased accordingly to maintain the batch volume under this level. Capital costs for the low flow system are based on the following equipment:

(1) Reaction system

- reaction/holding tank (5-day or less retention time)
- agitator
- transfer pump

(2) Polymer feed system (batch)

- chemical mix tank (5-day retention time)
- agitator
- chemical metering pump.

The polymer feed system is included for the low flow system for manufacturing processes operating in excess of 16 hours per day. The addition of polymer for plants operating 16 hours or less per

day is assumed to be unnecessary due to the additional settling time available.

Only one tank is required for both equalization and treatment since sedimentation is assumed to be accomplished during nonproduction hours (since the holding time is greater than the time required for treatment). Costs for a chemical precipitant feed system are not included since lime or caustic addition at low application rates can be assumed to be done manually by the operator. A common pump is used for transfer of both the supernatant and sludge through an appropriate valving arrangement.

As in the normal batch case, annual costs consist mainly of labor costs for the low flow system and are based on the following assumptions:

(1) Reaction system

- operating labor is assumed to be constant at 1 hr/batch (for pH control, sampling, filling, etc.); additional labor is also required for the manual addition of lime or caustic, ranging from 15 minutes to 1.5 hrs/batch depending on the feed requirement (1 to 500 lbs/batch)
- maintenance labor is 52 hrs/year (1 hr/week)
- energy costs are based on power requirements associated with the agitator and pump
- chemical costs are based on the use of hydrated lime or liquid caustic (50 percent)

(2) Polymer feed system (batch)

- see assumptions for normal batch treatment.

Combined Treatment

For small treatment systems (i.e., flow is less than 2,200 l/hr) where one or more pretreatment steps is required (e.g., cyanide precipitation or chromium reduction), significant cost savings can be realized by using a single reactor vessel and multiple treatment steps versus treatment in several separate tanks. For the nonferrous metals forming industry, this combined treatment approach was used, where applicable, in the precious metals forming and iron, copper and aluminum metal powders subcategories.

The treatment steps that may be performed in combined treatment include chemical emulsion breaking, oil-water separation, cyanide precipitation, chromium reduction, and chemical precipitation and settling. Only those steps specifically required by the waste streams at the plant are included in the design.

The design basis for combined treatment begins with the chemical precipitation unit. This unit is designed to hold wastewater from the plant for a period up to five days, based on the optimal

cost of capital equipment and operating costs. The total retention time required is calculated by summing the individual retention times associated with each treatment step. The tank size is then calculated based on the larger of either the holdup time or the total retention time.

The equipment that may be used in combined treatment includes:

- (1) Manual lime or caustic addition
- (2) Batch reactor tank
- (3) Pump
- (4) Agitator
- (5) Polymer feed system (if required)
- (6) FeSO_4 feed system (if required)
- (7) H_2SO_4 feed system (if required)
- (8) $\text{Na}_2\text{S}_2\text{O}_5$ feed system (if required)
- (9) Belt skimmer (if required).

The design bases such as dosages and feed equipment are identical to those presented in the respective treatment discussions for batch operation, with the following exceptions:

- (1) Annual costs for chemical addition are adjusted by the number of days of holdup
- (2) Batch reactor tank annual costs are recalculated as follows:
 - one hour/batch for operating labor for each treatment step except chromium reduction, where 0.5 hour/batch is used
 - 52 hours/year total maintenance
- (3) The chemical feed rates for identical chemicals required in separate treatment steps are additive.

The capital and annual costs calculated by combined treatment are apportioned to each treatment step as follows:

<u>Treatment Step</u>	<u>Cost Items</u>
Chemical Precipitation	Batch reactor tank Lime addition Pump Agitator Polymer feed system
Cyanide Precipitation	FeSO_4 feed system H_2SO_4 feed system
Chromium Reduction	$\text{Na}_2\text{S}_2\text{O}_5$ feed system H_2SO_4 feed system (if cyanide precipitation is not present)

Chemical Emulsion Breaking

Belt skimmer
H₂SO₄ feed system (if cyanide precipitation or chromium reduction is not present)

Vacuum Filtration

The underflow from the clarifier at 3 percent solids is routed to a rotary precoat vacuum filter, which dewateres sludge to a cake of 20 percent dry solids. The dewatered sludge is disposed of by contract hauling and the filtrate is recycled to the chemical precipitation step.

The capacity of the vacuum filter, expressed as square feet of filtration area, is based on a yield of 14.6 kg of dry solids/hr per square meter of filter area (3 lbs/hr/ft²), a solids capture of 95 percent and an excess capacity of 30 percent. It was assumed that the filter was operated eight hours/operating day.

Cost data were compiled for vacuum filters ranging from 0.9 to 69.7 m² (9.4 to 750 ft²) of filter surface area. Based on a total annualized cost comparison, it was assumed that it was more economical to directly contract haul clarifier underflow streams which were less than 50 l/hr (0.23 gpm), rather than dewater by vacuum filtration before hauling.

The costs for the vacuum filtration system include the following equipment:

- (1) Vacuum filter with precoat but no sludge conditioning
- (2) Housing
- (3) Influent transfer pump
- (4) Slurry holding tank
- (5) Sludge pumps.

The vacuum filter is sized based on 8 hrs/day operation. The slurry holding tank and pump are excluded when the treatment system operates 8 hrs/day or less. It was assumed in this case that the underflow from the clarifier directly enters the vacuum filter and that holding tank volume for the slurry in addition to the clarifier holding capacity was unnecessary. For cases where the treatment system is operated for more than 8 hrs/day, the under-flow is stored during vacuum filter non-operating hours. Accordingly, the filter is sized to filter the stored slurry in an 8 hour period each day. The holding tank capacity is based on the difference between the plant and vacuum filter operating hours plus an excess capacity of 20 percent.

Cost curves for direct capital and annual costs are presented in Figures VIII-17 and VIII-18, for vacuum filtration. Two cost curves are presented, one for stainless steel filter systems and one for carbon steel filter systems. The stainless steel filter and appurtenances are used for sludges from cyanide

precipitation, carbon steel filters for all other sludges. Annual cost for both designs are presented in Figure VIII-19.

The following assumptions were made for developing capital and annual costs:

- (1) Annual costs associated with the vacuum filter were developed based on continuous operation (24 hrs/day, 365 days/year). These costs were adjusted for a plant's individual operating schedule by assuming that annual costs are proportional to the hours the vacuum filter actually operates. Thus, annual costs were adjusted by the ratio of actual vacuum filter operating hours per year (8 hrs/day x number days/year) to the number of hours in continuous operation (8,760 hrs/year).
- (2) Annual vacuum filter costs include operating and maintenance labor (ranging from 200 to 3,000 hrs/year as a function of filter size), maintenance materials (generally less than 5 percent of capital cost), and energy requirements (mainly for the vacuum pumps).
- (3) Enclosure costs for vacuum filtration were based on applying rates of \$45/ft² and \$5/ft²/year for capital and annual costs, respectively to the estimated floor area required by the vacuum filter system. The capital cost rate for enclosure is the standard value as discussed below in the costs for enclosures discussion. The annual cost rate accounts for electrical energy requirements for the filter housing. Floor area for the enclosure is based on equipment dimensions reported in vendor literature, ranging from 300 ft² for the minimum size filter (9.4 ft²) to 1,400 ft² for a vacuum filtration capacity of 1,320 ft².

Multimedia Filtration

Multimedia filtration is used as a wastewater treatment polishing device to remove suspended solids not removed in previous treatment processes. The filter beds consist of graded layers of coarse anthracite coal and fine sand. The equipment used to determine capital and annual costs are as follows:

- (1) Gravity flow, vertical steel cylindrical filters with media (anthracite and sand)
 - (2) Influent storage tank sized for one backwash volume
 - (3) Backwash tank sized for one backwash volume
 - (4) Backwash pump to provide necessary flow and head for backwash operations
- air scour system

(5) Influent transfer pump

- piping, valves, and a control system.

The hydraulic loading rate is 7,335 lph/m² (180 gph/ft²) and the backwash loading rate is 29,340 lph/m² (720 gph/ft²). The filter is backwashed once per 24 hours for 10 minutes. The backwash volume is provided from the stored filtrate.

Effluent pollutant concentrations are based on the Agency's combined metals data base for treatability of pollutants by filtration technology.

Cartridge-type filters are used instead of multimedia filters to treat small flows (less than 800 liters/hour) since they are more economical than multimedia filters at these flows (based on a least total annualized cost comparison). The effluent quality achieved by these filters was equivalent to the level attained by multimedia filters. The equipment items used to determine capital and annual costs for membrane filtration are as follows:

- (1) Influent holding tank sized for 8 hours retention
- (2) Pump
- (3) Prefilter
 - prefilter cartridges
 - prefilter housings
- (4) Membrane filter
 - membrane filter cartridges
 - housing

The majority of annual cost is attributable to replacement of the spent prefilter and membrane filter cartridges. The maximum loading for the prefilter and membrane filter cartridges was assumed to be 0.225 kg per 0.254 m units length of cartridge. The annual energy and maintenance costs associated with the pump are also included in the total annual costs. Cost curves for direct capital and annual costs for multimedia filtration and capital costs for cartridge filtration are presented in Figure VIII-20. Annual costs for cartridge filtration are obtained from Table VIII-11.

Ion Exchange

This technology is applicable to precious metals recovery and final effluent polishing in the precious metals subcategory. It operates by absorption of charged precious metal ions onto a strongly anionic resin, which replaces the metal ions with chloride or hydroxide ions. It has been found that loading of

the resin to exhaustion and recovery of metals through combustion is preferred over regeneration; separation efficiency of the desired metals during regeneration is not usually adequate.

EPA has determined that removal of precious metal ions is achievable at no net cost, since the annual value of recovered metal exceeds the annualized cost of column operation. This analysis was based on median flows and concentrations of precious metals at a model plant. The mass of metal recovered was calculated using a treatability value for each metal (Au, Pt, Pd) of 0.01 mg/l (0.007 mg/l for silver). The metal value was determined by assuming 2/3 of the market price for each metal. This was compared to the cost of operating and depreciating the ion exchange column.

Contract Hauling

Concentrated sludge and waste oils are removed on a contract basis for off-site disposal. The cost of contract hauling depends on the classification of the waste as being either hazardous or nonhazardous. For nonhazardous wastes, a rate of \$0.106/liter (\$0.40/gallon) was used in determining contract hauling costs. The cost for contract hauling hazardous wastes was developed from a survey of waste disposal services and varies with the amount of waste hauled. No capital costs are associated with contract hauling. Annual cost curves for contract hauling nonhazardous and hazardous wastes are presented in Figure VIII-21.

Enclosures

The costs of enclosures for equipment considered to require protection from inclement weather were accounted for separately from the module costs (except for vacuum filtration). In particular, chemical feed systems were generally assumed to require enclosure.

Costs for enclosures were obtained by first estimating the required enclosure area and then multiplying this value by the \$/ft² unit cost. A capital cost of \$45/ft² was estimated, based on the following:

- structure (including roofing, materials, insulation, etc.)
- site work (masonry, installation, etc.)
- electrical and plumbing.

The rate for annual costs of enclosures is \$5/ft²/yr which accounts for energy requirements for heating and lighting the enclosure.

The required enclosure area is determined as the amount of total required enclosure area which exceeds the enclosure area esti-

mated to be available at a particular plant. It was assumed that a common structure could be used to enclose all equipment needing housing unless information was available to indicate that separate enclosures are needed (e.g., due to plant layout). The individual areas are estimated at 50 ft² per feed system. The available enclosure areas associated with each plant site were based on experience from site visits at numerous plants. For plant flows less than 1,100 l/hr, between 1,100 l/hr and 10,800 l/hr, and over 10,800 l/hr, the estimated available areas are 150 ft², 200 ft², and 250 ft², respectively.

The estimated available area did not exceed the required enclosure area at any plant in this category.

Segregation

Estimation of costs for segregation of process wastewaters for the nonferrous metals forming category is required by the frequency of multiple subcategories and categories present at plants covered by this regulation. Eighty-two of the approximately 150 plants for which costs were estimated for this regulation are such plants. Because the subcategories and categories represented at these plants may have different arrays of regulated pollutants, the possibility exists for mass allowances to be incorporated into a plant's permit that are in fact not required from a treatment standpoint. EPA seeks to avoid such a situation due to its potential for allowing additional pollutants to be discharged into the environment. As discussed in Section X, EPA took steps to minimize monitoring difficulties that could arise from this situation. However, segregation of wastewater containing different pollutants may be required for optimal environmental benefit. EPA does not seek to discourage combined treatment of process wastewater where such treatment provides effective removal of regulated pollutants.

Segregation costs, which are essentially the costs associated with transporting wastewater from its point of generation to the treatment system, are therefore a function of the subcategories and categories present at the plant. In case I, which is the most common, the nonferrous metals forming flow is a small portion of the total process wastewater flow. The cost of segregating the flow from each nonferrous metals forming process at a particular plant was estimated by multiplying a per stream segregation cost by the number of waste streams in each subcategory that are present at the plant. These costs are then attributed to each forming subcategory.

In case II, the nonferrous metals forming wastewater is the major wastewater flow. Here the cost is also calculated by using the per stream cost, however, the number of wastewater streams not associated with the major nonferrous metals forming subcategory were used. The costs were then assigned to the major nonferrous metals forming subcategory to reflect the cost of compliance by the major subcategory with its effluent limitations.

The per stream segregation costs and assumptions are listed in Table VIII-14.

Finally, an additional cost for segregation must be included for separation of process wastewaters that are discharged from the same equipment, where this equipment is used to process metals that are in separate subcategories. For instance, the same surface treatment rinse tank may rinse titanium parts over a certain period and then be used for rinsing of nickel parts. The cost for this segregation is represented by the cost of a holding tank of 4 hours retention, a pump, and connecting piping. The resulting cost was assigned to each nonferrous metals forming subcategory for which wastewater is discharged from the common equipment.

For the purpose of evaluating the economic impact of the nonferrous metals forming regulation, the Agency estimated the compliance cost for each plant on the basis of a combined wastewater treatment system. Nonferrous metals forming plants that generate process wastewater which is regulated by more than one nonferrous metals forming subcategory with different model end-of-pipe treatment requirements may be able to comply with permit requirements using a less costly treatment system than a system which will treat all process wastewater to meet the most stringent limitations.

Costs for segregation of wastewaters not included in this regulation (e.g., noncontact cooling water) were also included in the compliance cost estimates. The capital costs for segregating the above streams were determined using a rate of \$6,900 for each stream requiring segregation. This rate is based on the purchase and installation of 50 feet of 4-inch piping (with valves, pipe racks, and elbows) for each stream. Annual costs associated with segregation are assumed to be negligible.

Where a common stormwater-process wastewater piping system was used at a plant, costs were included for both segregation of each process waste stream to treatment (based on the above rate) and segregation of stormwater for rerouting around the treatment system. Stormwater segregation cost is \$8,800 based on the underground installation of 300 feet of 24-inch diameter concrete pipe.

COMPLIANCE COST ESTIMATION

A cost summary was prepared for each plant. An example of this summary for plants that were costed by the computer model may be found in Table VIII-15, page . Referring to this table, five types of data are included for each option: run number, total capital costs, required capital costs, total annual costs, and required annual costs. Run number refers to which computer run the costs were derived from.

Total capital costs include the capital cost estimate for each piece of wastewater treatment equipment necessary to meet mass

limitations. Required capital costs are determined by considering the equipment and wastewater treatment system a plant currently has in place. As discussed previously, the required capital costs reflect the estimates of the actual capital cost the facility will incur to purchase and install the necessary treatment equipment by accounting for what that facility already has installed.

For plants that discharge wastewater in more than one subcategory in the nonferrous metals forming category, or in more than one category, the compliance costs must be allocated to the different subcategories and categories. In general, this allocation is done based on the flow contribution of each subcategory and category. For instance, if 33 percent of the flow came from the nickel and cobalt forming subcategory, the titanium forming subcategory, and the electroplating category each, the capital and annual costs allocated to each of the two forming subcategories and the other category would be 33 percent.

An exception to this rule occurs when preliminary treatment steps such as chromium reduction are performed on only a portion of the total plant wastewater flow. In this case, the costs associated with the preliminary step are allocated solely to the subcategories and categories that discharge water requiring that treatment. Where flow reduction is included, the costs are apportioned as above keeping constant the portion(s) borne by subcategories where flow is not reduced. This prevents compliance costs from increasing for a subcategory from option to option when no regulatory flow change has been established. Examples and detailed calculation sheets for the apportionment of costs at each plant are contained in the public record for this rulemaking.

NONWATER QUALITY ASPECTS

The elimination or reduction of one form of pollution may aggravate other environmental problems. Therefore, Sections 304(b) and 306 of the Act require EPA to consider the nonwater quality environmental impacts (including energy requirements) of certain regulations. In compliance with these provisions, EPA has considered the effect of this regulation on air pollution, solid waste generation, water scarcity, and energy consumption. This regulation was circulated to and reviewed by EPA personnel responsible for nonwater quality environmental programs. While it is difficult to balance pollution problems against each other and against energy utilization, the Administrator has determined that the impacts identified below are justified by the benefits associated with compliance with the limitations and standards. The following are the nonwater quality environmental impacts associated with compliance with BPT, BAT, NSPS, PSES, and PSNS.

Air Pollution, Radiation, and Noise

In general, none of the wastewater treatment or control processes causes air pollution. Steam stripping of ammonia has a potential

to generate atmospheric emissions; however, with proper design and operation, air pollution impacts are prevented. None of the wastewater treatment processes cause objectionable noise or have any potential for radiation hazards.

Solid Waste Disposal

As shown in Section V, the waste streams being discharged contain large quantities of toxic and other metals; the most common method of removing the metals is by chemical precipitation. Consequently, significant volumes of heavy metal-laden sludge are generated that must be disposed of properly.

The technologies that directly generate sludge are:

1. Cyanide precipitation,
2. Chemical precipitation (lime or caustic),
3. Multimedia filtration, and
4. Oil water separation.

Table VIII-15 presents the sludge volumes generated by plants for each regulatory option in each subcategory, page .

The estimated sludge volumes generated from wastewater treatment were obtained from material balances performed by the computer model and extrapolated to the entire category. Generally, the solid waste requiring disposal is a dewatered sludge resulting from vacuum filtration, which contains 20 percent solids (by weight). The solids content will be lower in cases where it is more economical to contract haul a waste stream directly from the process without undergoing treatment.

A major concern in the disposal of sludges is the contamination of soils, plants, and animals by the heavy metals contained in the sludge. The leaching of heavy metals from sludge and subsequent movement through soils is enhanced by acidic conditions. Sludges formed by chemical precipitation possess high pH values and thus are resistant to acid leaching. Since the largest amount of sludge that results from the alternatives is generated by chemical precipitation, it is not expected that metals will be readily leached from the sludge. Disposal of sludges in a lined sanitary landfill will further reduce the possibility of heavy metals contamination of soils, plants, and animals.

Other methods of treating and disposing sludge are available. One method currently being used at a number of plants is reuse or recycle, usually to recover metals. This is especially common at plants in the precious metals forming subcategory. Since the metal concentrations in some sludges may be substantial, it may be cost-effective for some plants to recover the metal fraction of their sludges prior to disposal.

Wastes generated by nonferrous metal formers are subject to regulation under Subtitle C of the Resource Conservation and Recovery Act (RCRA) if they are hazardous. However, the Agency

examined solid wastes similar to those that would be generated at nonferrous metals forming plants by the suggested treatment technologies (that is, the sludges from lime and settle treatment) and believes they are not hazardous wastes under the Agency's regulations implementing Subtitle C of RCRA. The one exception to this is solid waste generated by cyanide precipitation. This sludge is expected to be hazardous and this judgement was included in this study. None of the noncyanide wastes are specifically listed as hazardous, nor are they likely to exhibit one of the four characteristics of hazardous waste (see 40 CFR Part 261) based on the recommended technology of chemical precipitation and sedimentation, preceded where necessary by hexavalent chromium reduction. By the addition of a small excess of lime during treatment, similar sludges, specifically toxic metal-bearing sludges generated by other industries such as the iron and steel industry passed the Extraction Procedure (EP) toxicity test (see 40 CFR 261.24). Thus, the Agency believes that nonferrous metals forming wastewater treatment sludges will similarly not be EP toxic if the recommended technology is applied.

The Agency is not proposing an allowance for discharge of spent solvents from the solvent degreasing operations at nonferrous metals forming plants. Disposal of the spent solvent may be subject to regulation under RCRA. However, no plant in the nonferrous metals forming industry is known to currently discharge the spent solvents. Therefore, the cost of disposal of the spent solvents has not been included in estimating the cost of this proposed regulation because all plants which use solvent degreasing already incur those costs.

Although solid wastes generated as a result of these guidelines are not expected to be hazardous, generators of these wastes must test the waste to determine if the wastes meet any of the characteristics of hazardous waste (see 40 CFR 261.10). The Agency also may list these wastes as hazardous under 40 CFR 261.11.

If these wastes are hazardous, as defined by RCRA, they will come within the scope of RCRA's "cradle to grave" hazardous waste management program, requiring regulation from the point of generation to point of final disposition. EPA's generator standards require generators of hazardous nonferrous metals forming wastes to meet containerization, labelling, recordkeeping, and reporting requirements; if plants dispose of hazardous wastes off-site, they have to prepare a manifest which tracks the movement of the wastes from the generator's premises to a permitted off-site treatment, storage, or disposal facility (see 40 CFR 262.20). The transporter regulations require transporters of hazardous wastes to comply with the manifest system to assure that the wastes are delivered to a permitted facility (see 40 CFR 263.20). Finally, RCRA regulations establish standards for hazardous waste treatment, storage, and disposal facilities allowed to receive such wastes (see 40 CFR Part 264).

Even if these wastes are not identified as hazardous, they still must be disposed of in compliance with the Subtitle D open dumping standards, implementing Section 4004 of RCRA (see 44 FR 53438, September 13, 1979). The Agency has calculated as part of the costs for wastewater treatment, the cost of hauling and disposing of these wastes.

Consumptive Water Loss

Treatment and control technologies that require extensive recycling and reuse of water may require cooling mechanisms. Evaporative cooling mechanisms can cause water loss and contribute to water scarcity problems—a primary concern in arid and semi-arid regions. While this regulation assumes water reuse, the overall amount of reuse through evaporative cooling mechanisms is low and the quantity of water involved is not significant. In addition, most nonferrous metals forming plants are located east of the Mississippi where water scarcity is not a problem. The Agency has concluded that consumptive water loss is insignificant and that the pollution reduction benefits of recycle technologies outweigh their impact on consumptive water loss.

Energy Requirements

The incremental energy requirements of a wastewater treatment system have been determined in order to consider the impact of this regulation on natural resource depletion and on various national economic factors associated with energy consumption. The calculation of energy requirements for wastewater treatment facilities proceeded in two steps. First, the portion of operating costs which were attributable to energy requirements was estimated for each wastewater treatment module. Then, these fractions, or energy factors, were applied to each module in all plants to obtain the energy costs associated with wastewater treatment for each plant. These costs were summed for each subcategory and converted to kW-hrs using the electricity charge rate previously mentioned (\$0.0483/kW-hr for March 1982). The total plant energy usage was calculated based on the data collection portfolios.

Table VIII-16, presents these energy requirements for each regulatory option in each subcategory. From the data in this table, the Agency has concluded that the energy requirements of the proposed treatment options will not significantly affect the natural resource base nor energy distribution or consumption in communities where plants are located.

Table VIII-1

BPT COSTS OF COMPLIANCE FOR THE
NONFERROUS METALS FORMING CATEGORY

Subcategory	Number of Direct Dischargers	Regulation Cost Estimates (1982)	
		Capital	Annual
Lead-Tin-Bismuth Forming	3	A	A
Magnesium Forming	1	148,000	96,000
Nickel-Cobalt Forming	12	392,000	186,000
Precious Metals Forming	4	226,000	98,000
Refractory Metals Forming	6	87,000	44,000
Titanium Forming	13	2,238,000	2,261,000
Uranium Forming	2	A	A
Zinc Forming	1	A	A
Zirconium-Hafnium Forming	4	359,000	327,000
Metal Powders	3	A	A

A - Based on confidential data.

Table VIII-2

BAT COSTS OF COMPLIANCE FOR THE
NONFERROUS METALS FORMING CATEGORY

Subcategory	Number of Direct Dischargers	Regulation Cost Estimates (1982)*	
		Capital	Annual
Lead-Tin-Bismuth Forming	3	A	A
Magnesium Forming	1	79,000	45,000
Nickel-Cobalt Forming	12	493,000	242,000
Precious Metals Forming	4	352,000	151,000
Refractory Metals Forming	6	135,000	68,000
Titanium Forming	13	2,124,000	2,192,000
Uranium Forming	2	A	A
Zinc Forming	1	A	A
Zirconium-Hafnium Forming	4	568,000	400,000
Metal Powders	3	A	A

*Costs are shown for selected option only (See Section X).

A - Based on confidential data.

Table VIII-3

PSES COSTS OF COMPLIANCE FOR THE
NCNFERROUS METALS FORMING CATEGORY

Subcategory	Number of Direct Dischargers	Regulation Cost Estimates (1982)*	
		Capital	Annual
Lead-Tin-Bismuth Forming	13	230,000	88,000
Magnesium Forming	2	A	A
Nickel-Cobalt Forming	26	3,622,000	2,159,000
Precious Metals Forming	26	824,000	373,000
Refractory Metals Forming	25	1,437,000	589,000
Titanium Forming	15	757,000	348,000
Uranium Forming	0	--	--
Zinc Forming	Exempted	--	--
Zirconium-Hafnium Forming	3	11,000	4,000
Metal Powders	27	512,000	334,000

*Costs are shown for selected option only (See Section XII).

A - Based on confidential data.

Table VIII-4

NONFERROUS METALS FORMING CATEGORY
COST EQUATIONS FOR RECOMMENDED TREATMENT AND CONTROL TECHNOLOGIES

Equipment	Equation	Range of Validity
Agitator, C-clamp	$C = 839.1 + 587.5 (HP)$ $A = 0.0483 \times (HPY) \times 0.746 (HP) + 0.05 (C)$	$0.25 < HP < 0.33$
Agitator, Top Entry	$C = 1,585.55 + 125.302 (HP) - 3.27437 (HP)^2$ $A = 0.0483 \times (HPY) \times 0.746 (HP) + 0.05 (C)$	$0.33 < HP < 5.0$
Ammonia Steam Stripping Column	$C = [(4,907.67 - 320.389) \times (DF) + 89.9082$ $\times (DF)^2] + [HT \times (30.3022 \times 86.9193$ $\times (DF) - 0.298958 \times (DF)^2] + NST] \times 1.1$ $A = 0$	$2 < DF < 12$
	$NST = 21 \times (18 + 0.00075 \times (W))$ $NST = 21 \times (41 + 0.0006 \times (W))$ $NST = 21 \times (59 + 0.00045 \times (W))$	$0 < W < 30,000$ $30,000 < W < 60,000$ $60,000 < W$
Clarifier, Concrete	$C = 78,400 + 32.65 (S) - 7.5357 \times 10^{-4}(S)^2$ $A = \exp[8.22809 - 0.224781 (\ln S) + 0.0563252$ $(\ln S)^2]$	$500 < S < 12,000$
Clarifier, Steel	$C = 41,197.1 + 72.0979(S) + 0.0106542(S)^2$ $A = \exp[8.22809 - 0.224781 (\ln S) + 0.0563252$ $(\ln S)^2]$	$300 < S < 2,800$
Contract Hauling	$C = 0$ $A = 0.40 (G)(HPY)$	Nonhazardous
	$C = 0$ $A = \exp[-0.0240857 + 1.02731 (\ln G)$ $- 0.0196787 (\ln G)^2](HPY)$	Hazardous

1511

Table VIII-4 (Continued)

NONFERROUS METALS FORMING CATEGORY
COST EQUATIONS FOR RECOMMENDED TREATMENT AND CONTROL TECHNOLOGIES

Equipment	Equation	Range of Validity
Cooling Tower System	$C = \exp[8.76408 + 0.07048 (\ln \text{CTON}) + 0.5095 (\ln \text{CTON})^2]$	$5 < \text{CTON} < 700$
	$A = \exp[9.08702 + 0.75544 (\ln \text{CTON}) + 0.140379 (\ln \text{CTON})^2]$	$5 < \text{CTON} < 700$
Equalization Basin	$C = 14,759.8 + 0.170817 (V) - 8.44271 \times 10^{-8} (V)^2$	$24,000 < V < 500,000$
	$C = 3,100.44 + 1.9041 (V) - 1.7288 \times 10^{-5} (V)^2$	$1,000 < V < 24,000$
	$C = \exp[4.73808 - 0.0628537 (\ln V) + 0.0754345 (\ln V)^2]$	$V < 1,000$
	$A = 0.05 (C)$	$0 < V < 500,000$
Feed System, Alum	$C = \exp[16.2911 - 0.206595 (\ln F) + 0.06448 (\ln F)^2]$	$10 < F < 1,000$
	$A = [0.52661 + 0.11913 (F) + 1.964 \times 10^{-8} (F^2)] \text{HPV}$	
Feed System, Caustic	Continuous feed:	
	$C = \exp[9.63461 + 8.36122 \times 10^{-3} (\ln F) + 0.0241809 (\ln F)^2]$	$0.4 < F < 417$
	$A = \exp[7.9707 - 4.45846 \times 10^{-3} (\ln F) + 0.0225972 (\ln F)^2] + 0.183 (\text{HPV})(F)$	
	Batch feed:	
	$C = \exp[7.50026 + 0.199364 (\ln F) + 0.0416602 (\ln F)^2]$	$1.5 < F < 1,500$
	$A = (21)[16 + 0.5 (\text{BPV}) + 0.131 (F)(\text{HPV})]$	

Table VIII-4 (Continued)

NONFERROUS METALS FORMING CATEGORY
COST EQUATIONS FOR RECOMMENDED TREATMENT AND CONTROL TECHNOLOGIES

Equipment	Equation	Range of Validity
	Low flow batch feed:	
	C = 250	X < 100
	A = 10.5 (BPY) + 0.131 (F) (HPY)	
Feed System, Defoamer	C = 980 A = 6.5 x 1005 (X) (HPY)	0 < X < 83,000
Feed System, Lime (Manual)	C = 0 A = (DPY)[0.074 (B) + 5.25 (NB)]	X < 2,000
Feed System, Lime (Batch)	C = 1,697.79 + 19.489 (B) - 0.036824 (B) ² C = 16,149.2 + 10.2512 (B) - 1,65864 x 10 ⁻³ (B) ² A = (BPY)[5.01989 + 0.0551812 (B) - 1.79331 x 10 ⁻⁵ (B) ²] - 1.65864	1 < B < 200 B > 200
Feed System, Lime (Continuous)	C = exp[6.32249 + 1.70246 (lnF) - 0.137186 (lnF) ²] A = exp[4.87322 + 1.78557 (lnF) + 0.136732 (lnF) ²] + (F)(HPY)(LC)	10 < F < 1,000
Feed System, Ferrous Sulfate	C = exp[10.1703 - 0.38694 (lnF) + 0.0765919 (lnF) ²] A = exp[9.696551 - 0.612972 (lnF) + 0.0960144 (lnF) ²] + 0.0575 (F) (HPY)	10.7 < F < 5,530
Feed System, Polymer	C = exp[9.83111 + 0.663271 (lnF) + 0.0557039 (lnF) ²] A = 0.42 (F)(HPY) + 1,050 C = 13,150 + 2,515.2 (F) A = exp[8.60954 + 0.04109 (lnF) + 0.0109397 (lnF) ²] + 2.25 (F)(HPY)	0.04 < F < 0.5 0.5 < F < 12

Table VIII-4 (Continued)
 NONFERROUS METALS FORMING CATEGORY
 COST EQUATIONS FOR RECOMMENDED TREATMENT AND CONTROL TECHNOLOGIES

1514

Equipment	Equation	Range of Validity
Feed System, Sulfuric Acid	$C = \exp[8.1441 + 0.23345 (\ln F) + 0.0180092 (\ln F)^2]$ $A = \exp[7.36913 + 0.0133111 (\ln F) + 0.029219 (\ln F)^2] + 0.03743 (F)(HPV)$	$0.01 < F < 3,200$
Filter, Multimedia	$C = 10,888 + 277.85 (SA) - 0.154337 (SA)^2$ $A = \exp[8.20771 + 0.275272 (\ln SA) + 0.0323124 (\ln SA)^2]$	$7 < SA < 500$
Filter, Membrane	$C = 290.48 + 31.441 (Y) - 0.050717 (Y)^2$ $A = [8.34253 \times 10^{-3} + 0.173683 (SR - 4.1435 \times 10^{-5} (SR)^2)](HPV)$ $C = -2,922.48 + 60.6411 (Y) - 0.065206 (Y)^2$ $A = [-0.0152849 + 0.172153 (SR) - 3.46041 \times 10^{-6} (SR)^2](HPV)$	$2 < Y < 140$ $140 < Y < 336$
Oil/Water Separator, Coalescent Type	$C = 5,542.07 + 65.7158 (Y) - 0.029627 (Y)^2$ $A = 783.04 + 6.3616 (Y) - 0.001736 (Y)^2$	$0 < Y < 700$
Oil/Water Separator, Belt-Type (Small Flow)	$C = 2,370$ $A = 1,300$ $C = 2,900$ $A = 1,500$	$0 < C < 25$ $0 < C < 25$
Piping, Recycle	$C = \exp[6.55278 + 0.382166 (\ln D) + 0.133144 (\ln D)^2] (0.01)(L)$ $A = 0$	$D > 1$

Table VIII-4 (Continued)

NONFERROUS METALS FORMING CATEGORY
COST EQUATIONS FOR RECOMMENDED TREATMENT AND CONTROL TECHNOLOGIES

Equipment	Equation	Range of Validity
Prefilter, Cartridge	$C = 283.353 + 25.9111 (Y) - 0.058203 (Y)^2$ $A = [0.118985 + 0.0803004 (SR) - 1.66003$ $\times 10^{-5} (SR)^2](HPV)$	$2 < Y < 140$
	$C = -2,612.73 + 51.568 (Y) - 0.059361 (Y)^2$ $A = [-3.82339 + 0.0937196 (SR) - 1.7736$ $\times 10^{-5} (SR)^2](HPV)$	$140 < Y < 336$
Pump, Centrifugal	$C = \exp[6.31076 + 0.228887(\ln Y) + 0.0206172$ $(\ln Y)^2]$ $A = \exp[6.67588 + 0.031335 (\ln Y) + 0.062016$ $(\ln Y)^2] (HPB)$	$3 < Y < 3,500$
Pump, Sludge	$C = 2,264.31 + 21.0097 (Y) - 0.0037265 (Y)^2$ $A = \exp[7.64414 + 0.192172 (\ln Y) + 0.0202428$ $(\ln Y)^2] (HPB)$	$5 < Y < 500$
Spray Rinsing System	$C = 4,212.72 - 0.009005 (X) + 1.004 \times 10^{-6}$ $(X)^2$ $A = 1.05 (HPV) + 0.02(C)$	
Sulfonator	$C = 14,336.3 + 38.1582 (F) - 0.156326 (F)^2$ $A = 6,934.09 + 2,704.2 (F) - 1.08636 (F)^2$	$4.0 < F < 350$
Tank, Batch Reactor	$C = \exp[4.73808 - 0.0628537 (\ln V) + 0.0754345$ $(\ln V)^2]$	$57 < V < 1,000$
	$C = 3,100.44 + 1.19041 (V) - 1.7288 \times 10^{-5} (V)^2$	
	$A = 1,090 + 21 (BPV)$ $A = \exp[8.65018 - 0.0558684 (\ln X) + 0.0145276$ $(\ln X)^2]$	$2,200 < X < 11,600$

Table VIII-4 (Continued)

NONFERROUS METALS FORMING CATEGORY
COST EQUATIONS FOR RECOMMENDED TREATMENT AND CONTROL TECHNOLOGIES

Equipment	Equation	Range of Validity
Tank, Concrete	C = 5,800 + 0.8V A = 0.02 (C)	24,000 < V < 500,000
Tank, Large Fiberglass	C = 3,100.44 + 1.19041 (V) - 1.7288 x 10 ⁻⁵ (V) ² A = 0.02 (C)	1,000 < V < 24,000
Tank, Small Fiberglass	C = exp[4.7308 - 0.0628537 (lnV) + 0.0754345 (lnV) ²] A = 0.02 (C)	57 < V < 1,000
Tank, Rectangular Fiberglass With Sparger System	C = 6,670.25 + 3.444 (V) - 25.084 (V) ^{0.5} - 1.11928 x 10 ⁻⁴ (V) ² A = [0.257195 - 0.00349 (V) ^{0.5} + 3.736 x 10 ⁻⁵ (V)](HPY)	1,000 < V < 13,000 1,000 < V < 13,000
Tank, Large Steel	C = 3,128.83 + 2.37281 (V) - 7.10689 x 10 ⁻⁵ (V) ² C = 14,759.8 + 0.170817 (V) - 8.44271 x 10 ⁻⁸ (V) ² A = 0.02 (C)	500 < V < 12,000 V < 25,000
Vacuum Filter	C = 71,083.7 + 442.3 (SA) - 0.233807 (SA) ² A = 17,471.4 + 677.408 (SA) - 0.484647 (SA) ²	9.4 < SA < 750
Vacuum Filter Housing	C = (45)[308.253 + 0.836592 (SA)] A = (4.96)[308.253 + 0.836592 (SA)]	9.4 < SA < 750

Table VIII-4 (Continued)

NONFERROUS METALS FORMING CATEGORY
COST EQUATIONS FOR RECOMMENDED TREATMENT AND CONTROL TECHNOLOGIES

Equipment	Equation	Range of Validity
Variable Definitions		
<p>A = Direct annual costs (1982 dollars/year) B = Batch chemical feed rate (pounds/batch) BD = Batch chemical feed rate (pounds/day) BPY = Number of batches per year C = Direct capital, or equipment costs (1982 dollars) D = Inner diameter of pipe (inches) DF = Inner diameter of column (feet) DPY = Days of operation per year F = Chemical feed rate (pounds/hour) G = Sludge disposal rate (gallons/hour) HP = Power requirement (horsepower) HPB = Fraction of time equipment is in operation HPY = Plant operating hours (hours/year) HT = Height of column (feet) L = Length of piping (feet) LC = Lime cost (\$/lb, March 1982) NB = Number of batches per day NST = Installed cost of column (1982 dollars) OC = Oil removed (gallons/day) S = Clarifier surface area (square feet) SA = Filter surface area (square feet) SR = Solids removed by filter (grams/hour) V = Tank capacity (gallons) W = Weight of column (pounds) X = Wastewater flow rate (liters/hour) Y = Wastewater flow rate (gallons/minute)</p>		

Table VIII-5

COMPONENTS OF TOTAL CAPITAL INVESTMENT

Number	Item	Cost
1	Bare Module Capital Costs	Direct capital costs ^a
2	Electrical & instrumentation	Included in item 1
3	Yard piping	Included in item 1
4	Enclosure	Included in item 1
5	Pumping	Included in item 1
6	Retrofit allowance	Included in item 1
7	Total Module Cost	Item 1 + items 2 through 6
8	Engineering/admin. & legal	10% of item 7
9	Construction/yardwork	0% of item 7
10	Total Plant Cost	Item 7 + items 8 through 9
11	Contingency	15% of item 10
12	Contractor's fee	10% of item 10
13	Total Construction Cost	Item 10 + items 11 through 12
14	Interest during construction	0% of item 13
15	Total Depreciable Investment	Item 13 + item 14
16	Land	0% of item 15
17	Working capital	0% of item 15
18	Total Capital Investment	Item 15 + items 16 through 17

^aDirect capital costs include costs of equipment and required accessories, installation, and delivery.

Table VIII-6

COMPONENTS OF TOTAL ANNUALIZED INVESTMENT

Number	Item	Cost
19	Bare Module Annual Costs	Direct annual costs ^a
20	Overhead	0% of item 15 ^b
21	Monitoring	See footnote ^c
22	Taxes and Insurance	1% of item 15
23	Amortization	CRF x item 15 ^d
24	Total Annualized Costs	Item 19 + items 20 through 23

^aDirect annual costs include costs of raw materials, energy, operating labor, maintenance and repair.

^bItem 15 is the total depreciable investment obtained from Table VIII-5.

^cSee page for an explanation of the determination of monitoring costs.

^dThe capital recovery factor (CRF) was used to account for depreciation and the cost of financing.

Table VIII-7

WASTEWATER SAMPLING FREQUENCY

Wastewater Discharge (liters per day)	Sampling Frequency
0 - 37,850	Once per month
37,851 - 189,250	Twice per month
189,251 - 378,500	Once per week
378,501 - 946,250	Twice per week
946,250+	Three times per week

Table VIII-8

POLLUTANT PARAMETERS IMPORTANT TO TREATMENT SYSTEM DESIGN

Parameter	Units
Flow rate	liters/hour
pH	pH units
Temperature	°F
Total suspended solids	mg/l
Acidity (as CaCO ₃)	mg/l
Aluminum	mg/l
Ammonia	mg/l
Antimony	mg/l
Arsenic	mg/l
Beryllium	mg/l
Cadmium	mg/l
Chromium (trivalent)	mg/l
Chromium (hexavalent)	mg/l
Cobalt	mg/l
Columbium	mg/l
Copper	mg/l
Cyanide (free)	mg/l
Cyanide (total)	mg/l
Fluoride	mg/l
Iron	mg/l
Lead	mg/l
Magnesium	mg/l
Manganese	mg/l
Mercury	mg/l
Molybdenum	mg/l
Nickel	mg/l
Oil and grease	mg/l
Phosphorus	mg/l
Selenium	mg/l
Silver	mg/l
Sulfate	mg/l
Tantalum	mg/l
Thallium	mg/l
Tin	mg/l
Titanium	mg/l
Tungsten	mg/l
Uranium	mg/l
Vanadium	mg/l
Zinc	mg/l
Zirconium	mg/l

Table VIII-9

THE RATIO OF SLUDGE TO INFLUENT WASTEWATER FLOW
FOR COST CURVE DEVELOPMENT

Subcategory Group	Wet (3%) Sludge Ratio	Dry (20%) Sludge Ratio
Ni-Co, U, Zr	0.14	0.02
Ti	0.66	0.10
Refractory Metals - I ^a	0.05	0.007
Refractory Metals - II ^b	0.89	0.13

^aThese include plants with surface treatment baths and rinses, sawing and grinding lubricants, and alkaline cleaning baths and rinses.

^bThese include plants with tumbling wastewater and sawing and grinding lubricants.

Table VIII-10

KEY TO COST CURVES AND EQUATIONS

Module	Capital Cost	Annual Cost
Spray Rinsing Equipment Pump	Figure VIII-4 Figure VIII-6	Table VIII-11 Figure VIII-6
Countercurrent Rinsing Tank, Rectangular Fiberglass Pump	Figure VIII-5 Figure VIII-6	Figure VIII-5 Figure VIII-6
Cyanide Precipitation	Figure VIII-10	Figure VIII-10
Chromium Reduction Batch Continuous	Figure VIII-11 Figure VIII-11	Table VIII-11 Figure VIII-11
Holding Tanks	Figure VIII-8	Figure VIII-8
Cooling Towers	Figure VIII-7	Figure VIII-7
Equalization	Figure VIII-9	Figure VIII-9
Chemical Emulsion Breaking	Figure VIII-14	Figure VIII-14
Oil Skimming	\$2,600	\$1,300
Chemical Precipitation and and Settling	Figure VIII-16	Figure VIII-16
Vacuum Filtration Carbon Steel Stainless Steel*	Figure VIII-17 Figure VIII-18	Figure VIII-19 Figure VIII-19
Multimedia Filtration	Figure VIII-20	Figure VIII-20 Table VIII-11
Contract Hauling		Figure VIII-21
Iron Co-Precipitation Low-Flow Flow < 499 l/hr 500 l/hr < Flow < 2,200 l/hr Batch and Continuous	\$ 250 \$2,510 Figure VIII-12	Figure VIII-13 Figure VIII-13 Figure VIII-13

*Used for sludges from cyanide precipitation.

Table VIII-11
COST EQUATIONS USED IN COST CURVE METHOD

Item	Equation	Range of Validity
Spray Rinsing Equipment	$A = 1.05 \text{ (HPY)}$	
Batch Chromium Reduction	$A = 1,925 + [8.84 - 10.5 \text{ (HPD/8)}] \text{ (DPY)}$	
Cartridge Filtration	$A = 1,000 + [0.119 + 9.306 \times 10^{-4} \text{ (X)} - 1.085 \times 10^{-9}] \text{ (HPY)}$	$0 < X < 800$

Variable Definitions:

A = Direct annual costs (1982 dollars/year)
 DPY = Operating days per year
 HPD = Operating hours per day
 HPY = Operating hours per year
 X = Wastewater flow rate (liters/hour)

Table VIII-12

NUMBER OF PLANTS FOR WHICH COSTS WERE SCALED.
FROM SIMILAR PLANTS

Subcategory	Number of Plants
Lead-Tin-Bismuth Forming	12
Magnesium Forming	1
Nickel-Cobalt Forming	5
Precious Metals Forming	9
Refractory Metals Forming	10
Titanium Forming	6
Uranium Forming	0
Zinc Forming	0
Zirconium-Hafnium Forming	0
Metal Powders	5

Table VIII-13

FLOW REDUCTION RECYCLE RATIO AND ASSOCIATED COST ASSUMPTIONS

Condition	Action
Option A:	
1. Actual flow from process* is greater than Option A.	1. Reduce flow to Option A at negligible cost. Use flow to cost combined treatment system.
2. Actual flow from process is less than Option A.	2. Use actual plant flow to cost combined treatment plant.
Options B and C:	
1. Actual flow from process is greater than Option A and no in-process flow reduction techniques are in place.	1. Reduce flow to Option A at zero cost. Reduce flow to Option B using recycle ratio.**
2. Actual flow from process is greater than Option A. The actual plant recycle ratio is known and results in a reduced flow less than Option A but greater than Option B.***	2. Reduce flow to Option A at zero cost. Reduce flow to Option B using recycle ratio.
3. Actual flow from process is greater than Option A. The actual plant recycle ratio is known and results in a flow less than Option B.	3. Reduce flow to Option A at zero cost. Set discharge from flow reduction equipment equal to actual plant reduced flow.
4. Actual flow from process is greater than Option A and the actual plant recycle is unknown.	4. Reduce flow to Option A at zero cost. Reduce flow to Option B using constant recycle ratio.

Table VIII-13 (Continued)
 FLOW REDUCTION RECYCLE RATIO AND ASSOCIATED COST ASSUMPTIONS

Condition	Action
5. Actual flow from process is less than Option A (but greater than Option B) and the actual plant recycle ratio is known and results in a flow less than Option B.	5. Set discharge from flow reduction equipment equal to actual plant reduced flow.
6. Actual flow from process is less than Option A (but greater than Option B) and the actual plant recycle ratio is unknown, zero, or results in a flow greater than Option B.	6. Set discharge from flow reduction equipment equal to Option B.
7. Actual flow from process is less than Option B using no reduction techniques.	7. Set discharge equal to actual plant flow.

*Flow before any reported flow reduction techniques (i.e., holding tanks, cooling towers, thickeners).

**The constant recycle ratio is calculated as: $R = \frac{\text{Option A Flow} - \text{Option B Flow}}{\text{Option A Flow}}$

***The actual plant recycle ratio is calculated as:

$R = \frac{\text{Flow Before Flow Reduction} - \text{Flow After Flow Reduction}}{\text{Flow Before Flow Reduction}}$

Note this table assumes:

Option A = Lime and settle.

Option B = Lime and settle with in-process flow reduction.

Option C = Lime, settle, and multimedia filtration with in-process flow reduction.

Table VIII-14
 SEGREGATION COST BASIS
 (1982 Dollars)

Total Flow to Treatment	Cost per Waste Stream	Cost Basis
<100 l/hr	\$1,380	100 feet of 4" Schedule 40, 180 psi PVC pipe, valves, fittings installed above grade in pipe racks
>100 l/hr, where each individual stream is <100 l/hr	\$1,380	As above
>100 l/hr, where one or more waste streams are >100 l/hr	\$6,900	500 feet of 4" Schedule 40, 180 psi PVC pipe, valves, fittings installed above grade in pipe racks

Table VIII-15

NONFERROUS METALS FORMING
SOLID WASTE GENERATION (kkg/yr)

Subcategory	BPT	BAT	PSES
Lead-Tin-Bismuth Forming	9.68	11.2	22.2
Magnesium Forming	189	191	33.2
Nickel-Cobalt Forming	81.7	113	3,800
Precious Metals Forming	19.0	22.3	58.7
Refractory Metals Forming	162	196	1,130
Titanium Forming	705	901	1,710
Uranium Forming	150	153	0
Zinc Forming	99.6	101	0
Zirconium-Hafnium Forming	65.6	80.3	2.23
Metal Powders	27.4	27.4	273

Table VIII-16

NONFERROUS METALS FORMING
ENERGY CONSUMPTION (1000 kW-hr/yr)

Subcategory	BPT	BAT	PSES
Lead-Tin-Bismuth Forming	330	330	890
Magnesium Forming	110	110	50
Nickel-Cobalt Forming	880	880	950
Precious Metals Forming	440	440	1,160
Refractory Metals Forming	330	330	1,260
Titanium Forming	880	880	580
Uranium Forming	220	220	
Zinc Forming	110	110	50
Zirconium-Hafnium Forming	440	440	110
Metal Powders	330	330	1,310

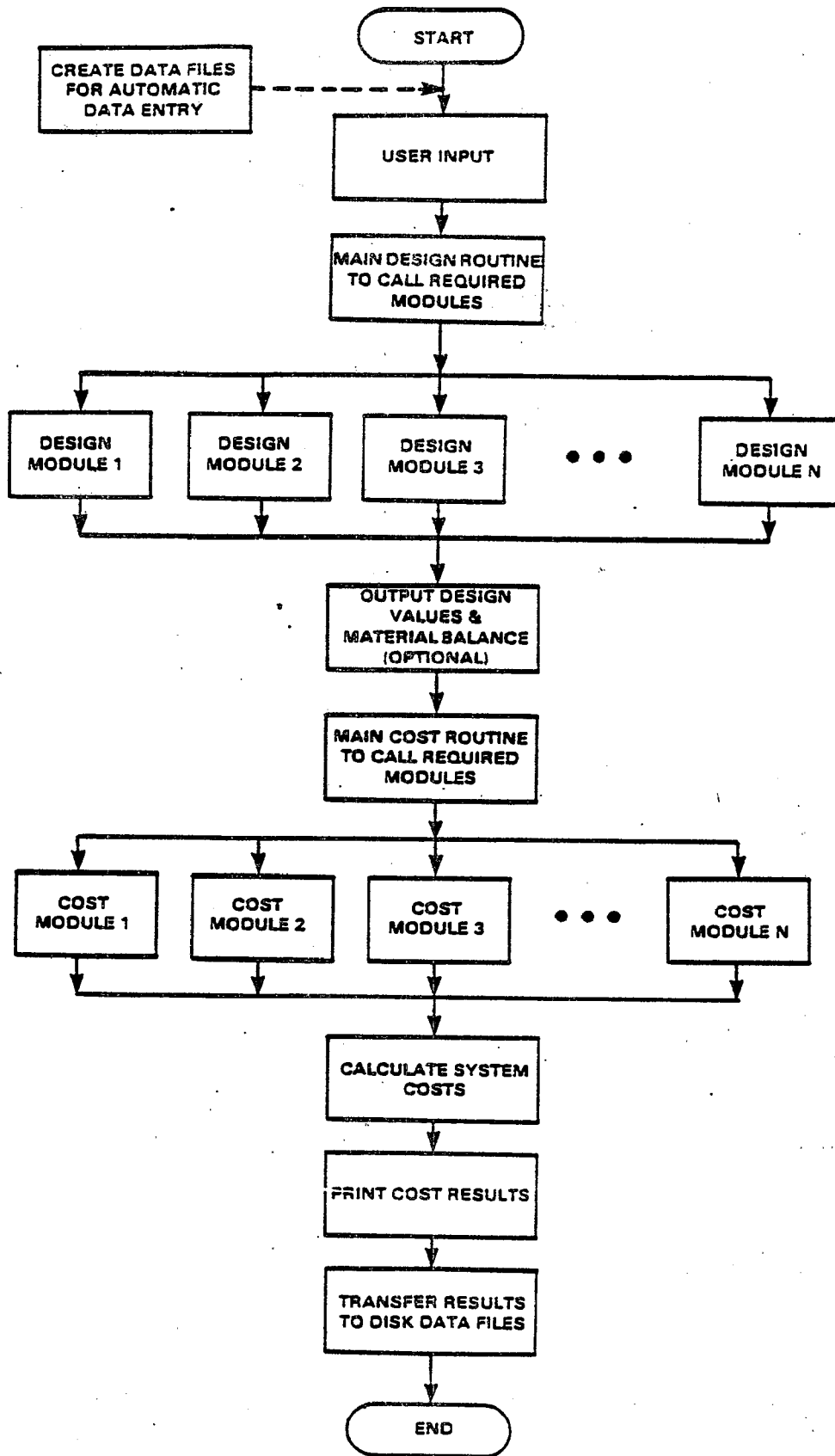

Figure VIII-1.

GENERAL LOGIC DIAGRAM OF COMPUTER COST MODEL

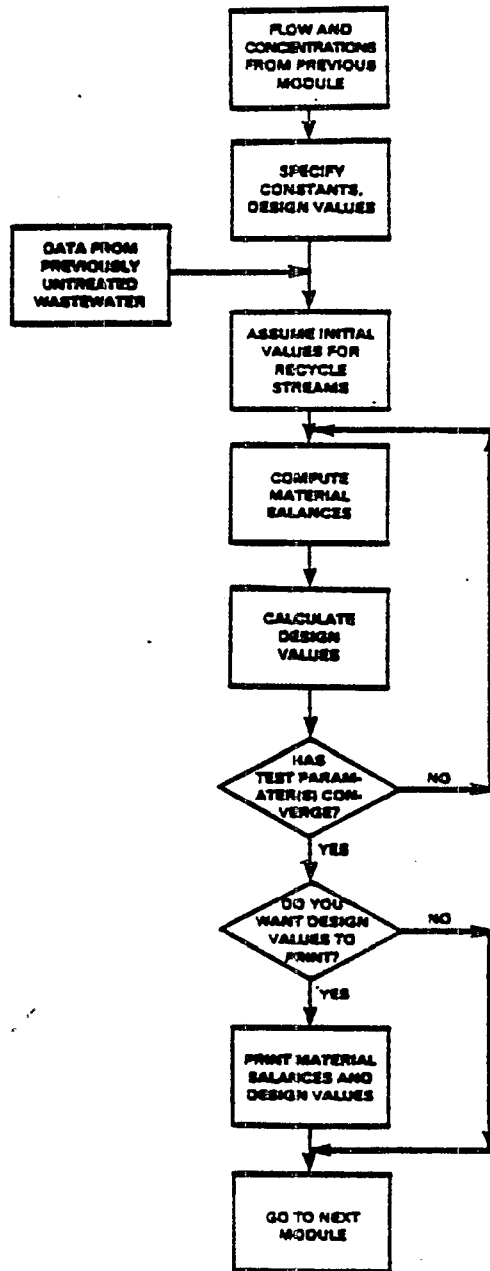

Figure VIII-2

LOGIC DIAGRAM OF MODULE DESIGN PROCEDURE

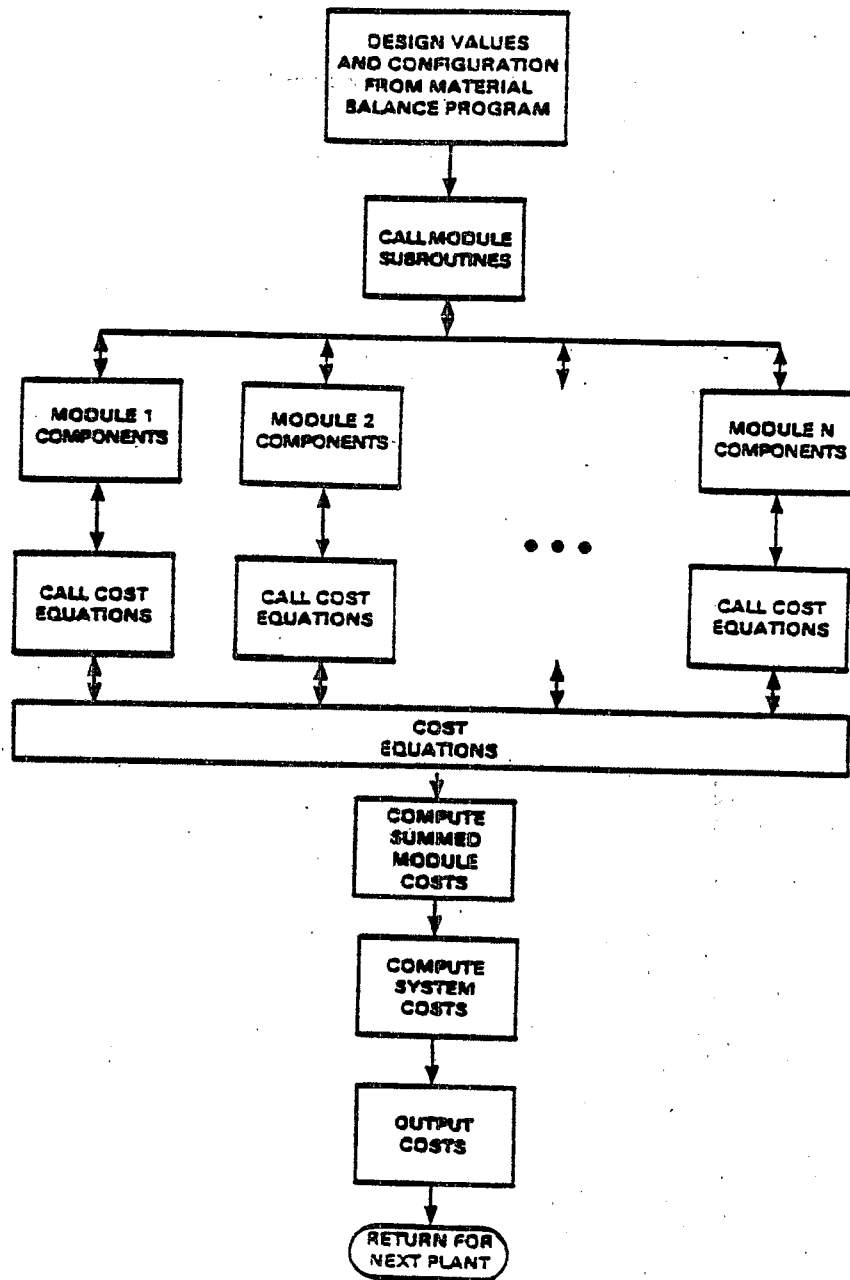

Figure VIII-3

LOGIC DIAGRAM OF THE COST ESTIMATION ROUTINE

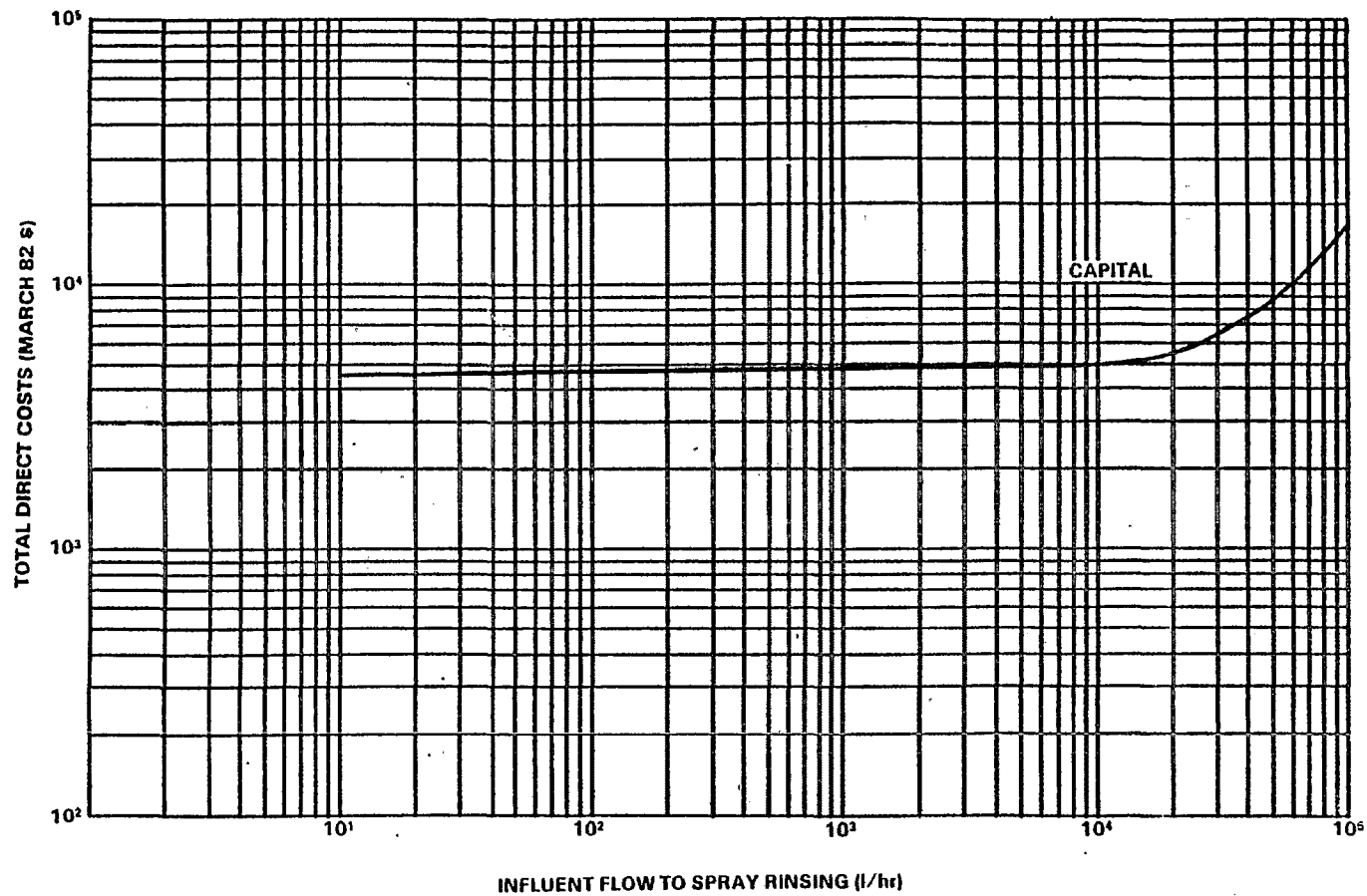

Figure VIII-4
CAPITAL COSTS OF A SPRAY RINSING SYSTEM

1535

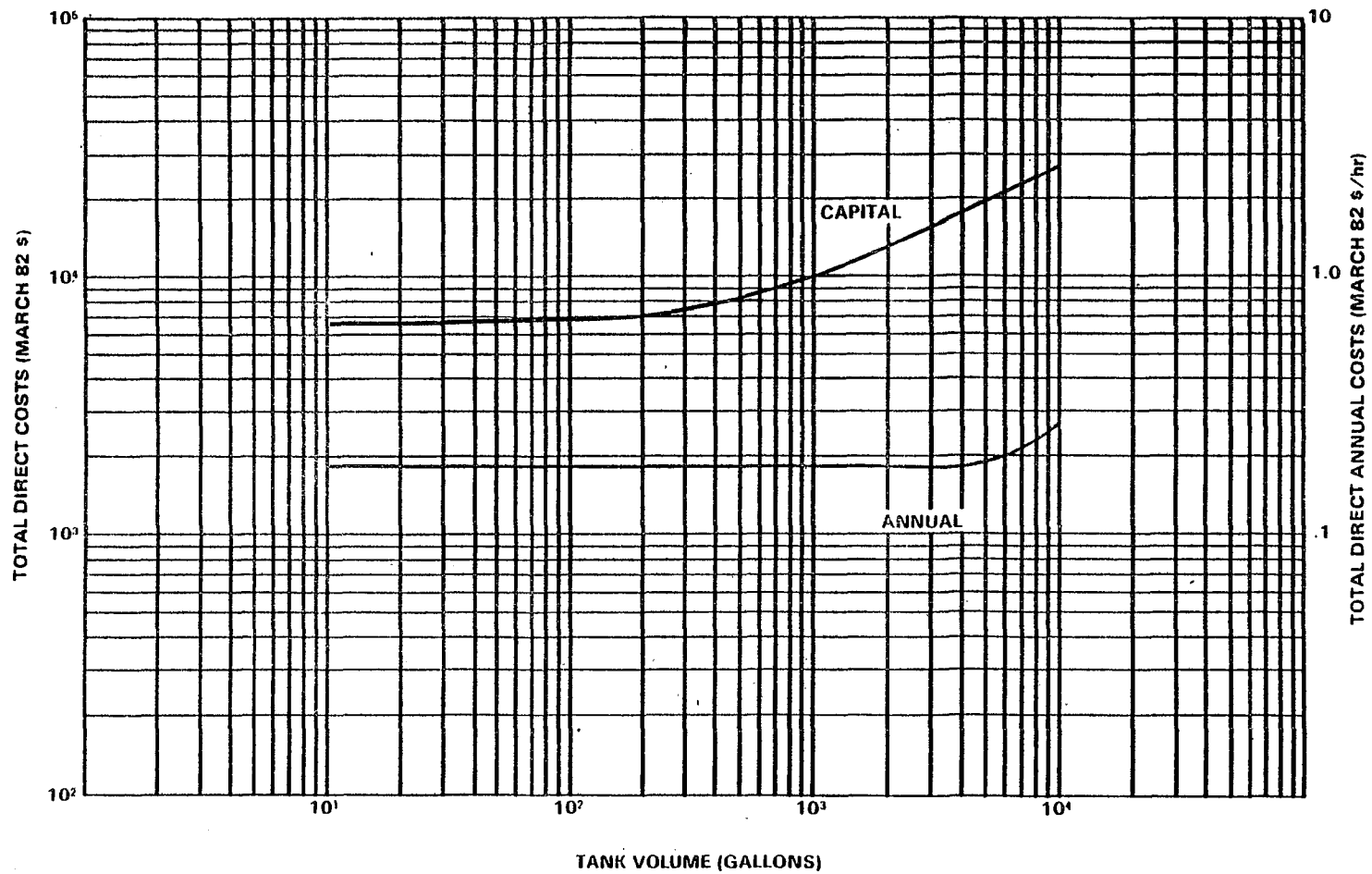

Figure VIII-5

CAPITAL AND ANNUAL COSTS OF AERATED RECTANGULAR FIBERGLASS TANKS

1536

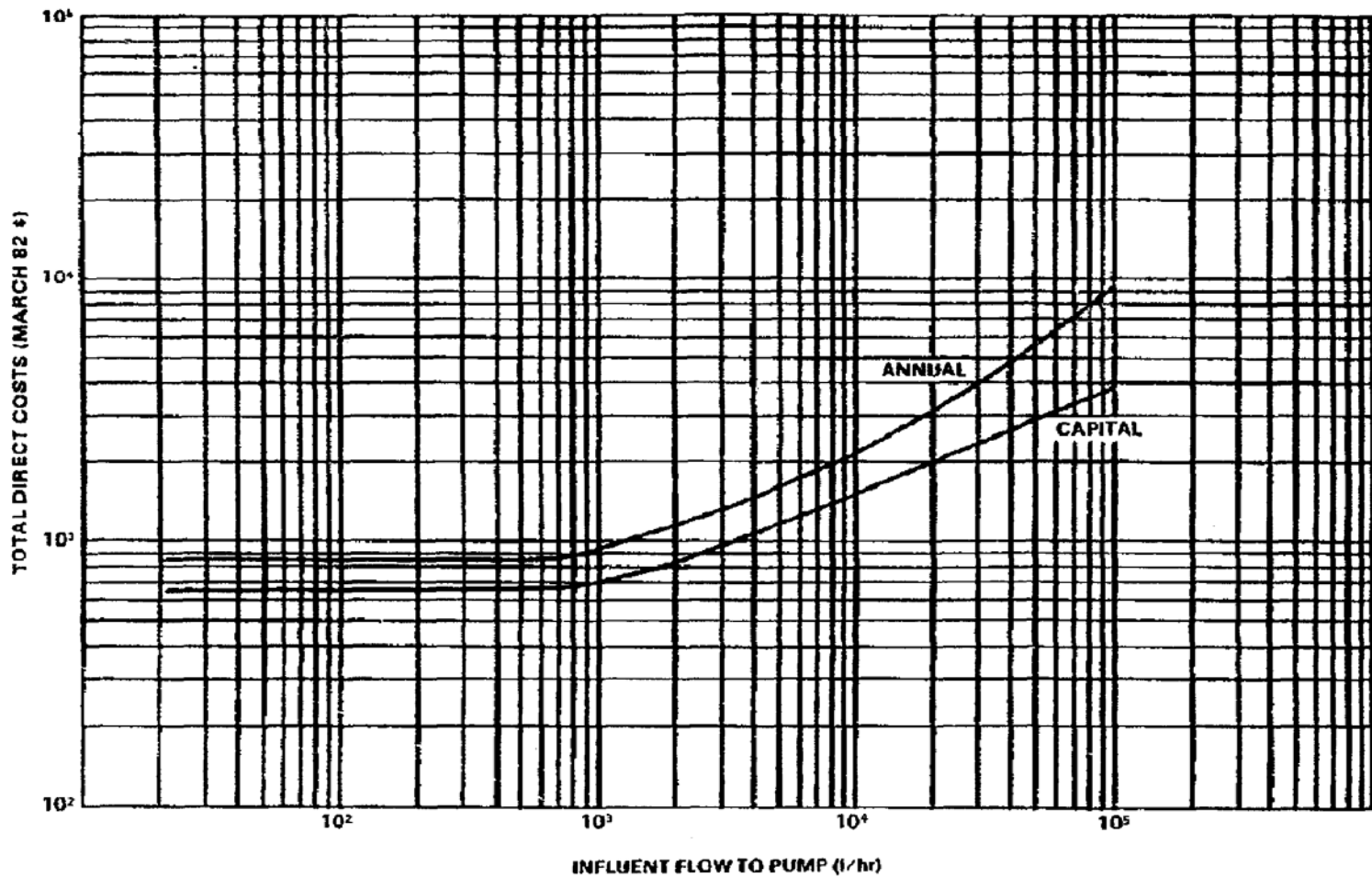

Figure VIII-6

CAPITAL AND ANNUAL COSTS OF CENTRIFUGAL PUMPS

1537

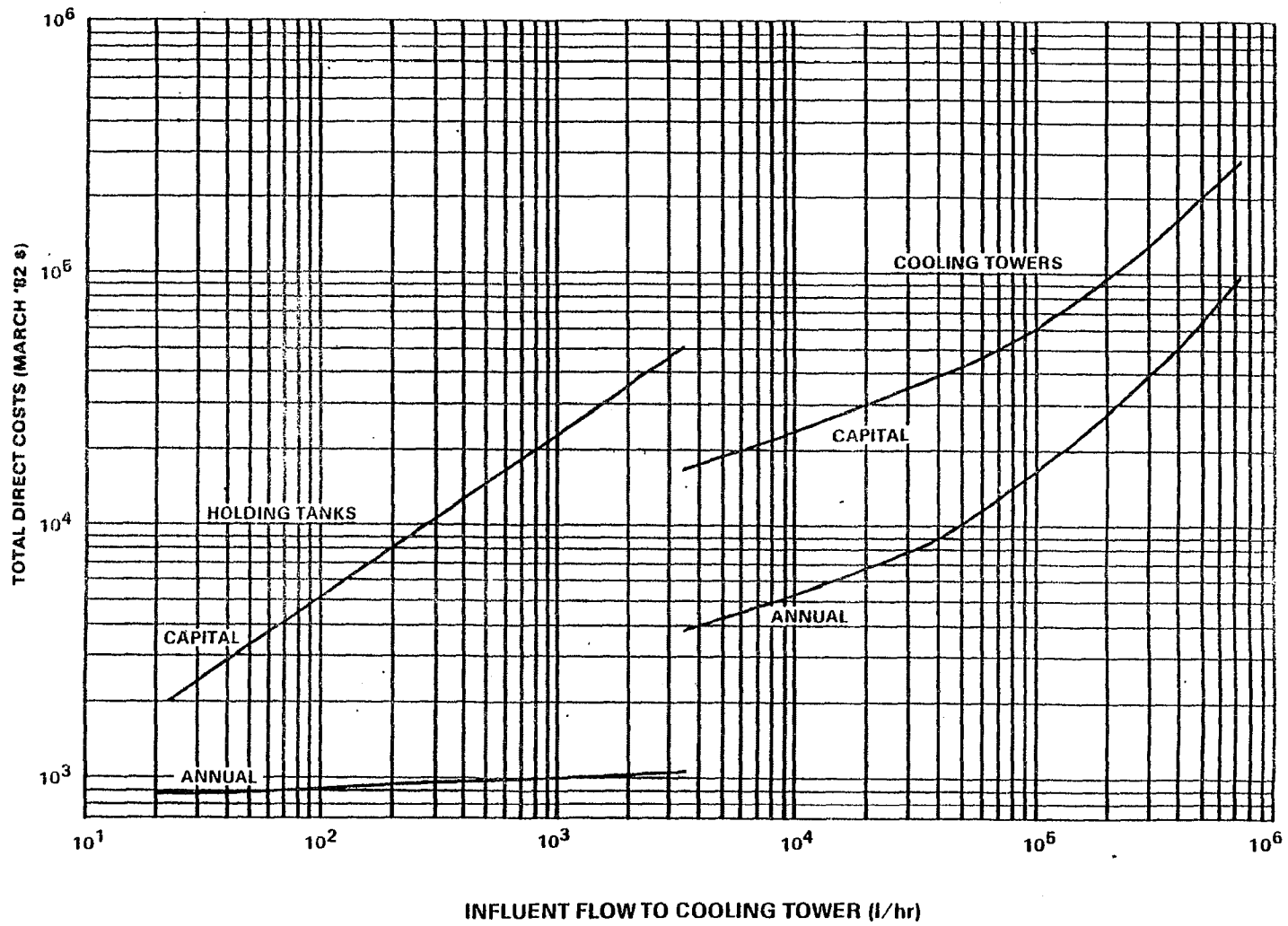

Figure VIII-7

CAPITAL AND ANNUAL COSTS OF COOLING TOWERS AND HOLDING TANKS

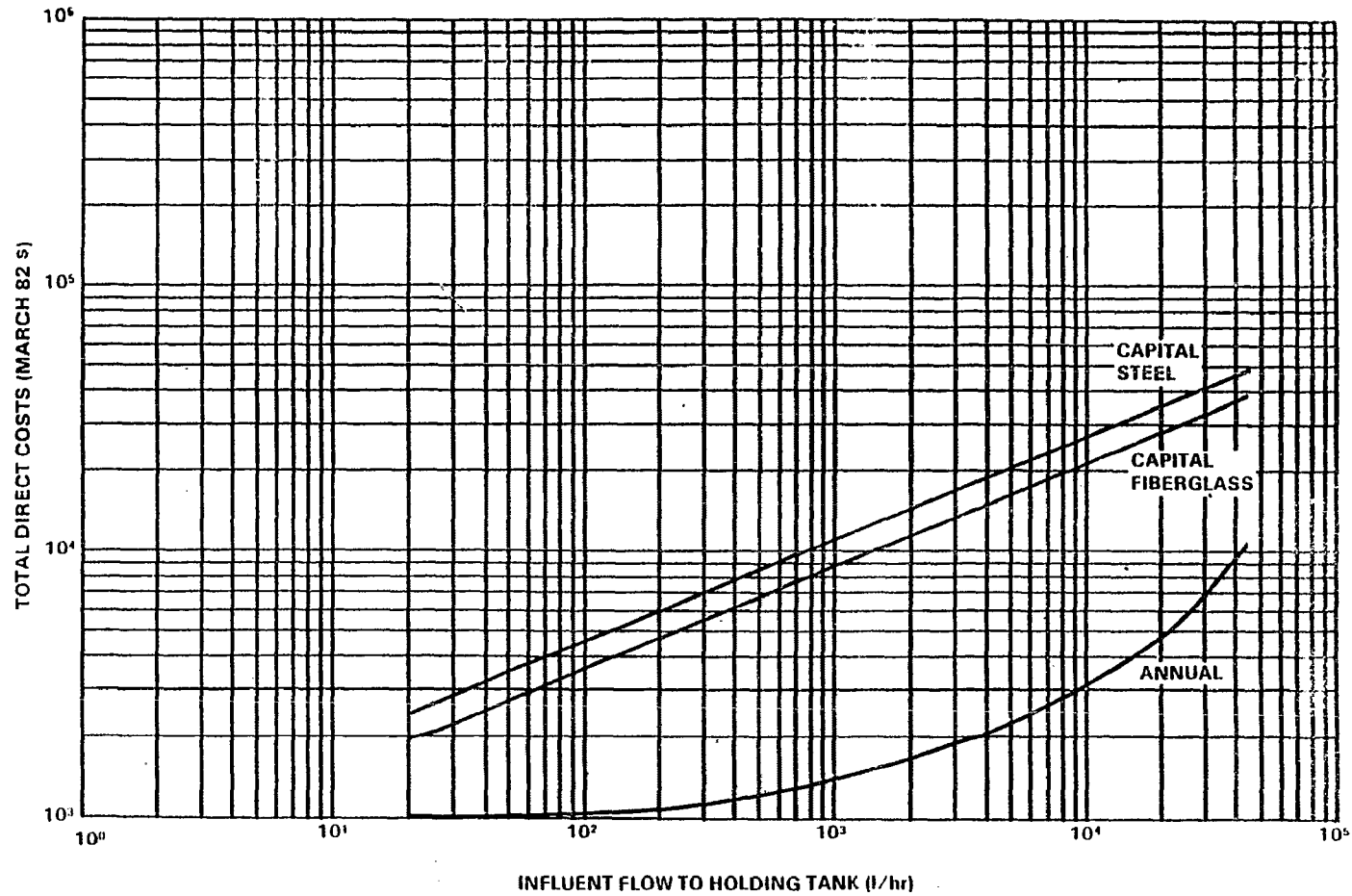

Figure VIII-8

CAPITAL AND ANNUAL COSTS OF HOLDING TANKS AND RECYCLE PIPING

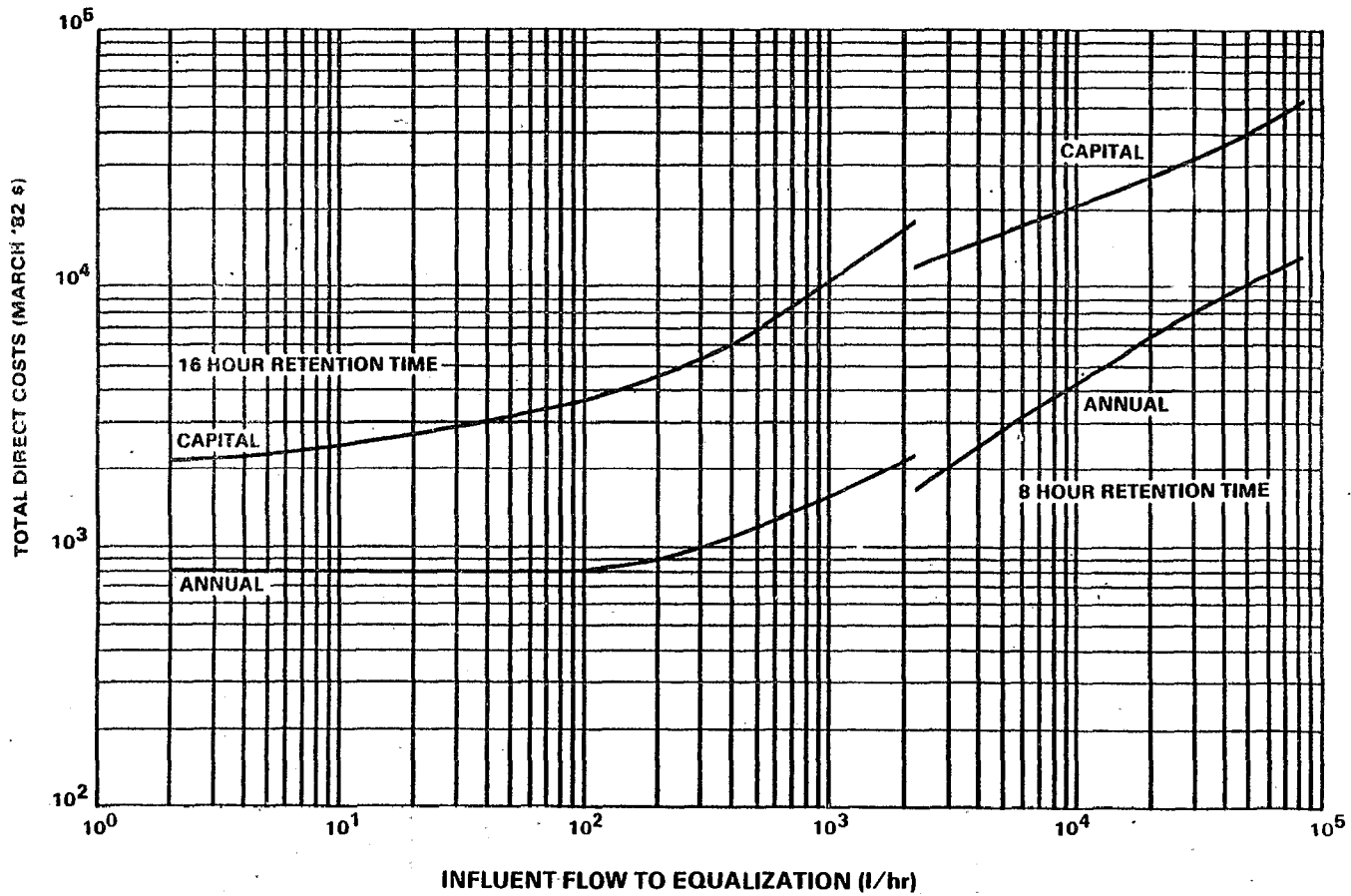

Figure VIII-9

CAPITAL AND ANNUAL COSTS OF EQUALIZATION

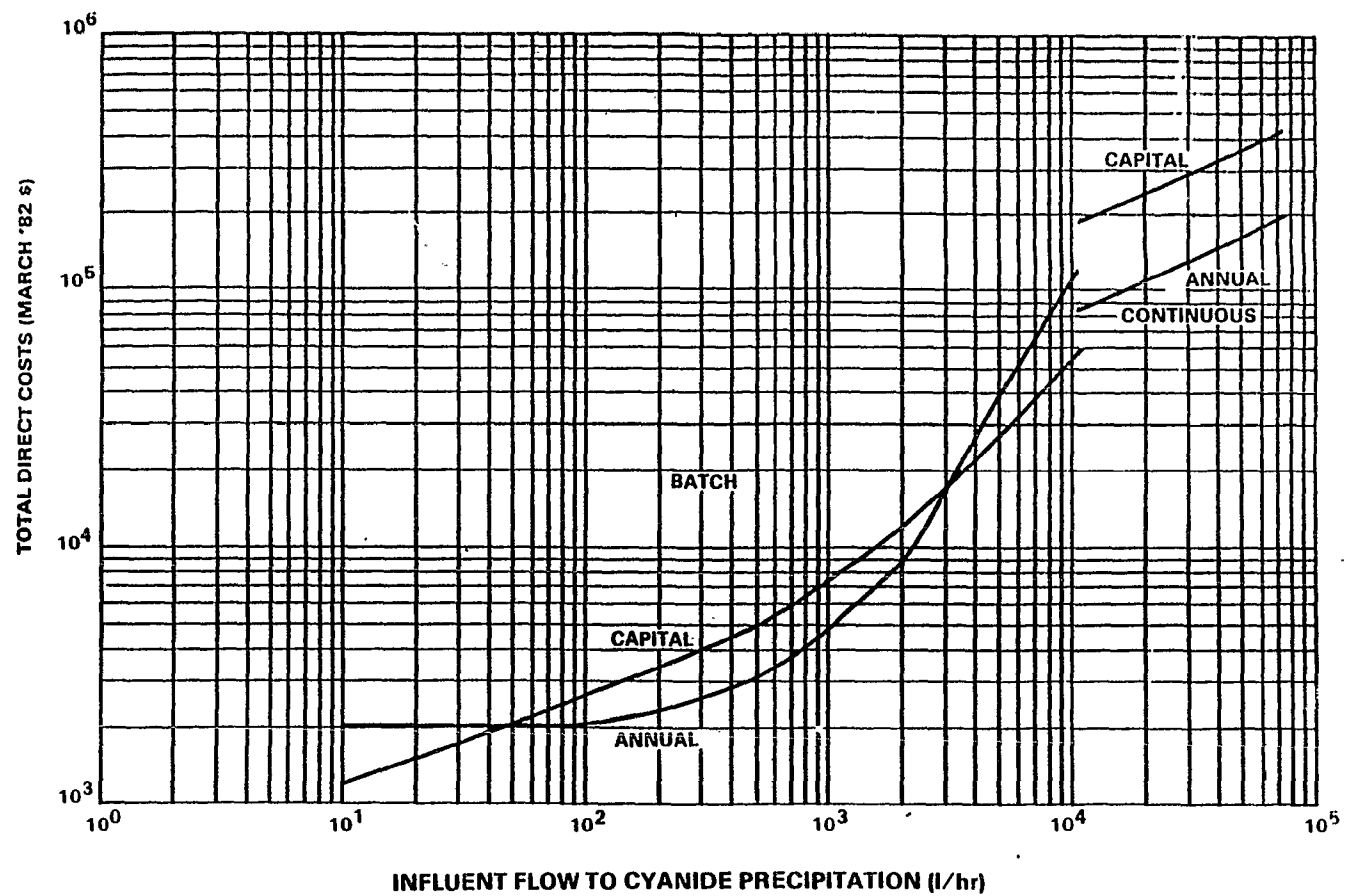

Figure VIII-10

CAPITAL AND ANNUAL COSTS OF CYANIDE PRECIPITATION

1541

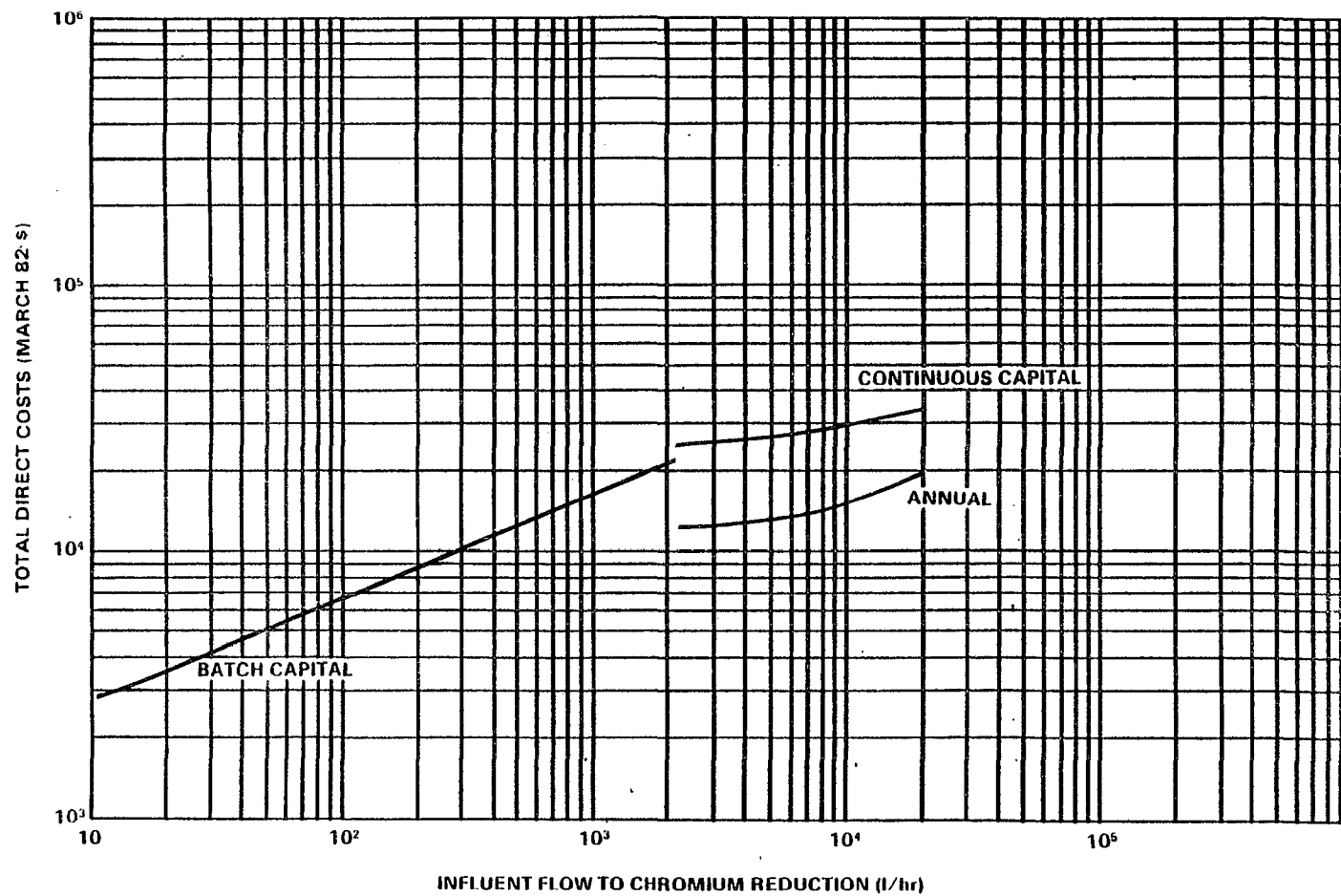

Figure VIII-11
CAPITAL AND ANNUAL COSTS OF CHROMIUM REDUCTION

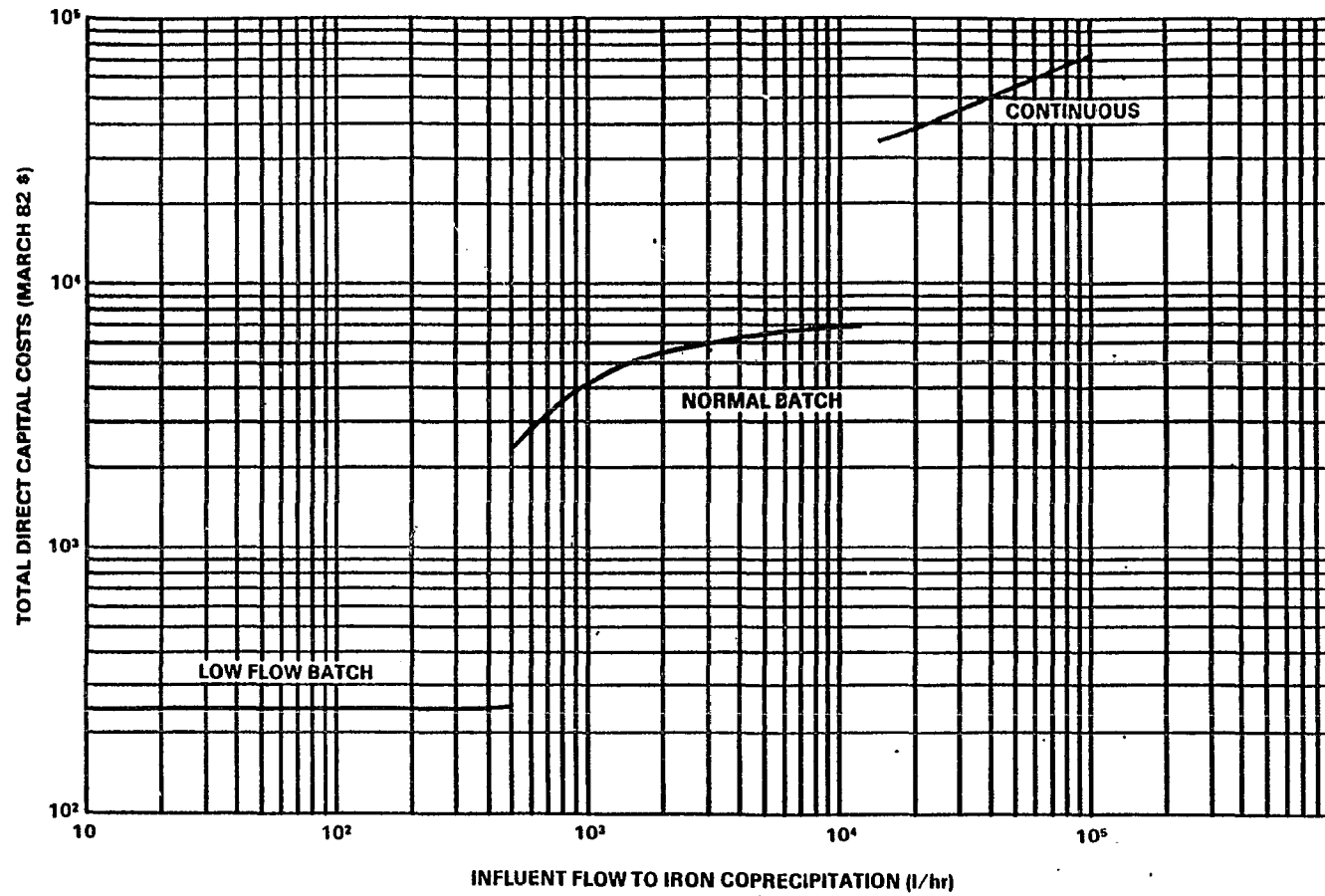

Figure VIII-12

CAPITAL COSTS OF IRON COPRECIPITATION

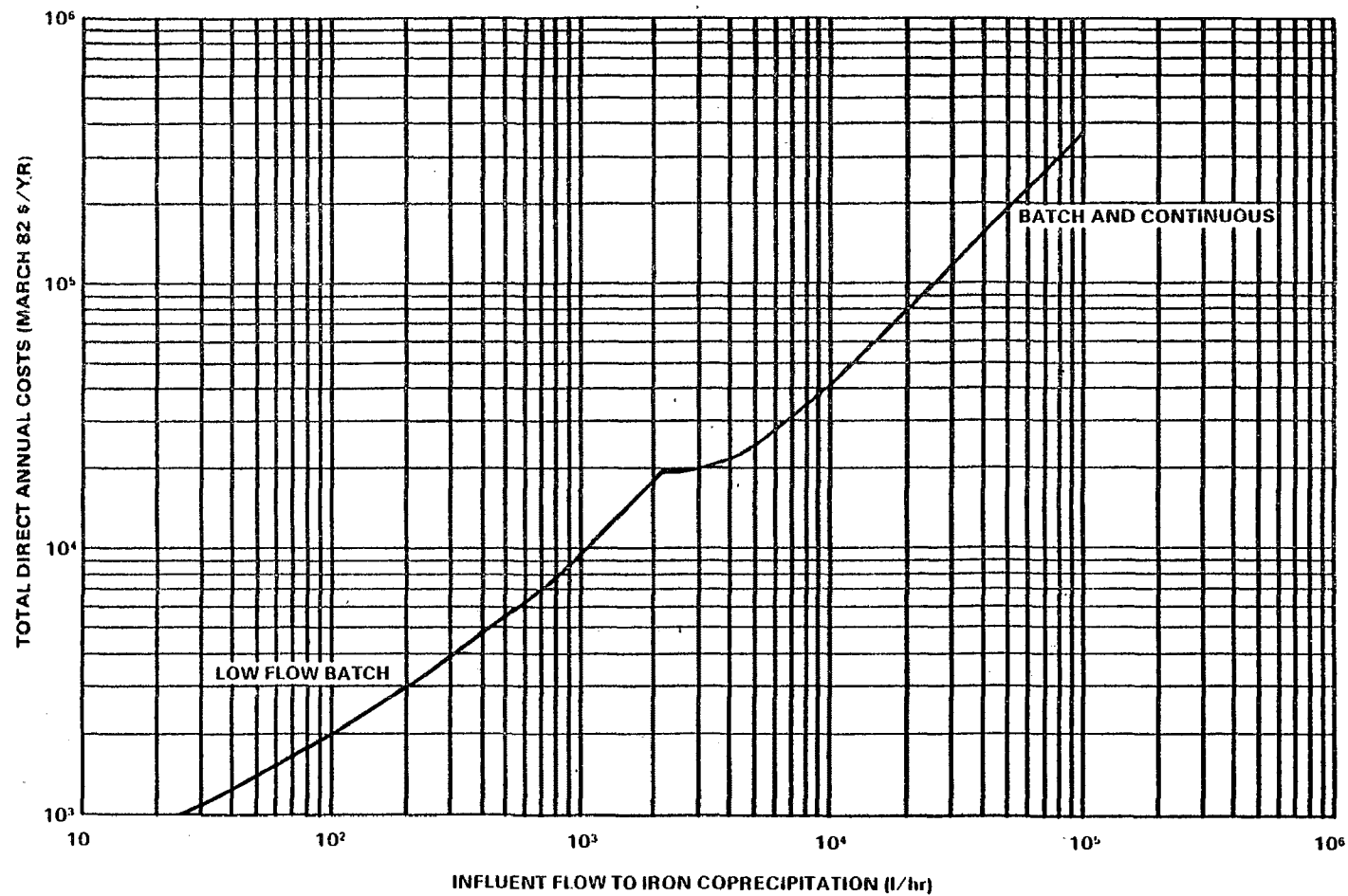

Figure VIII-13

ANNUAL COSTS OF IRON COPRECIPITATION

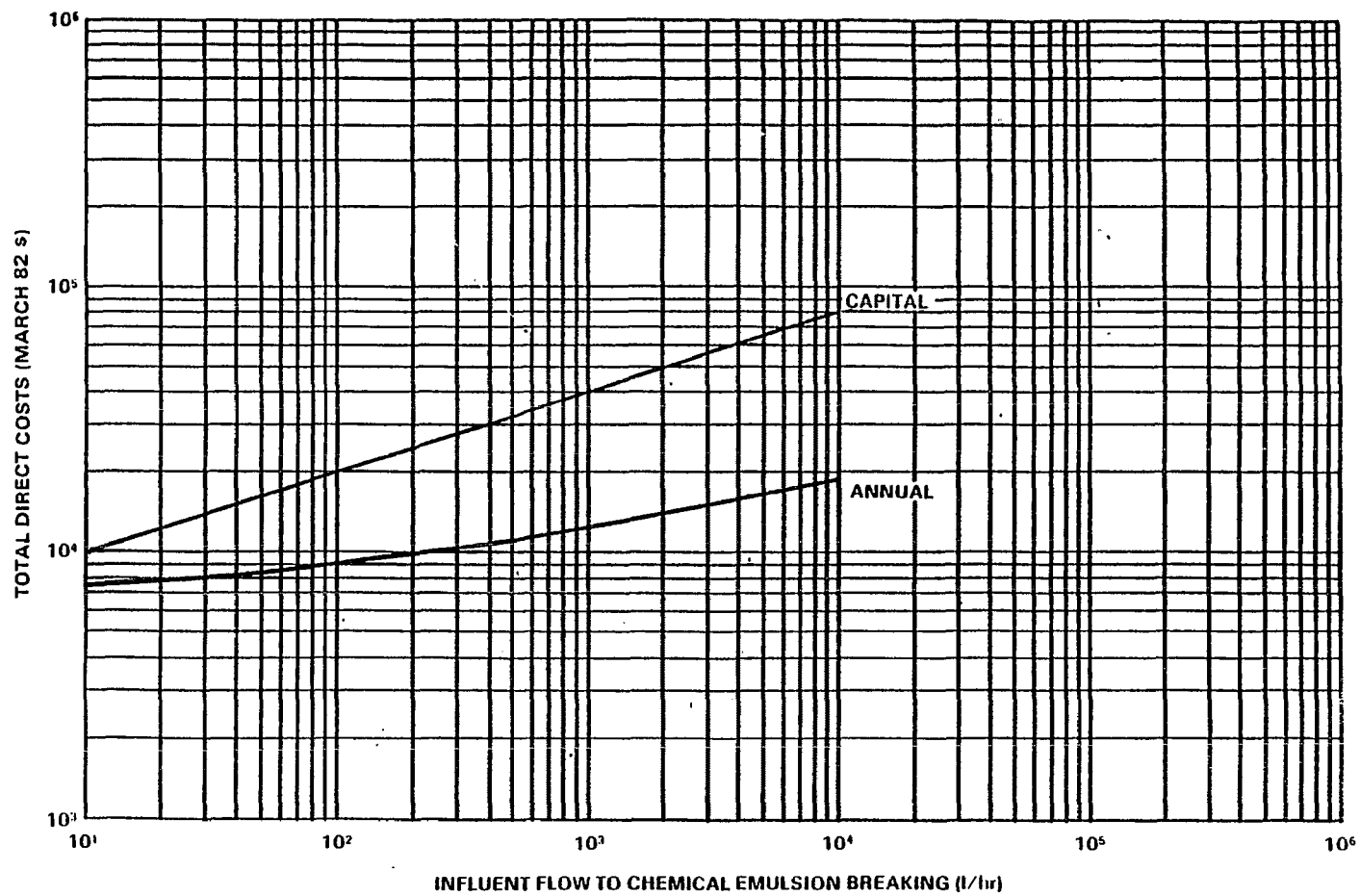

Figure VIII-14
CAPITAL AND ANNUAL COSTS OF CHEMICAL EMULSION BREAKING

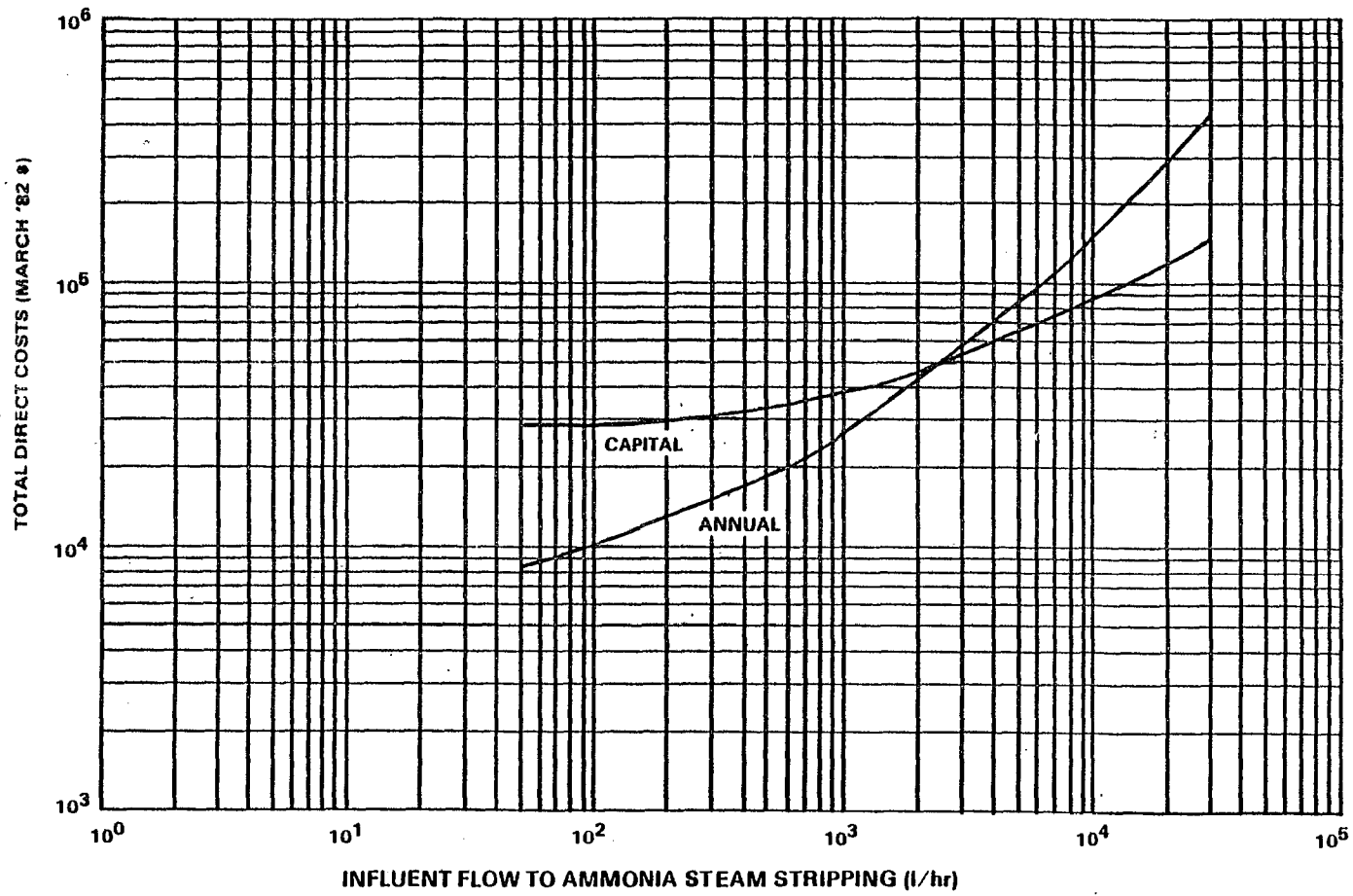

Figure VIII-15

CAPITAL AND ANNUAL COSTS OF AMMONIA STEAM STRIPPING

1546

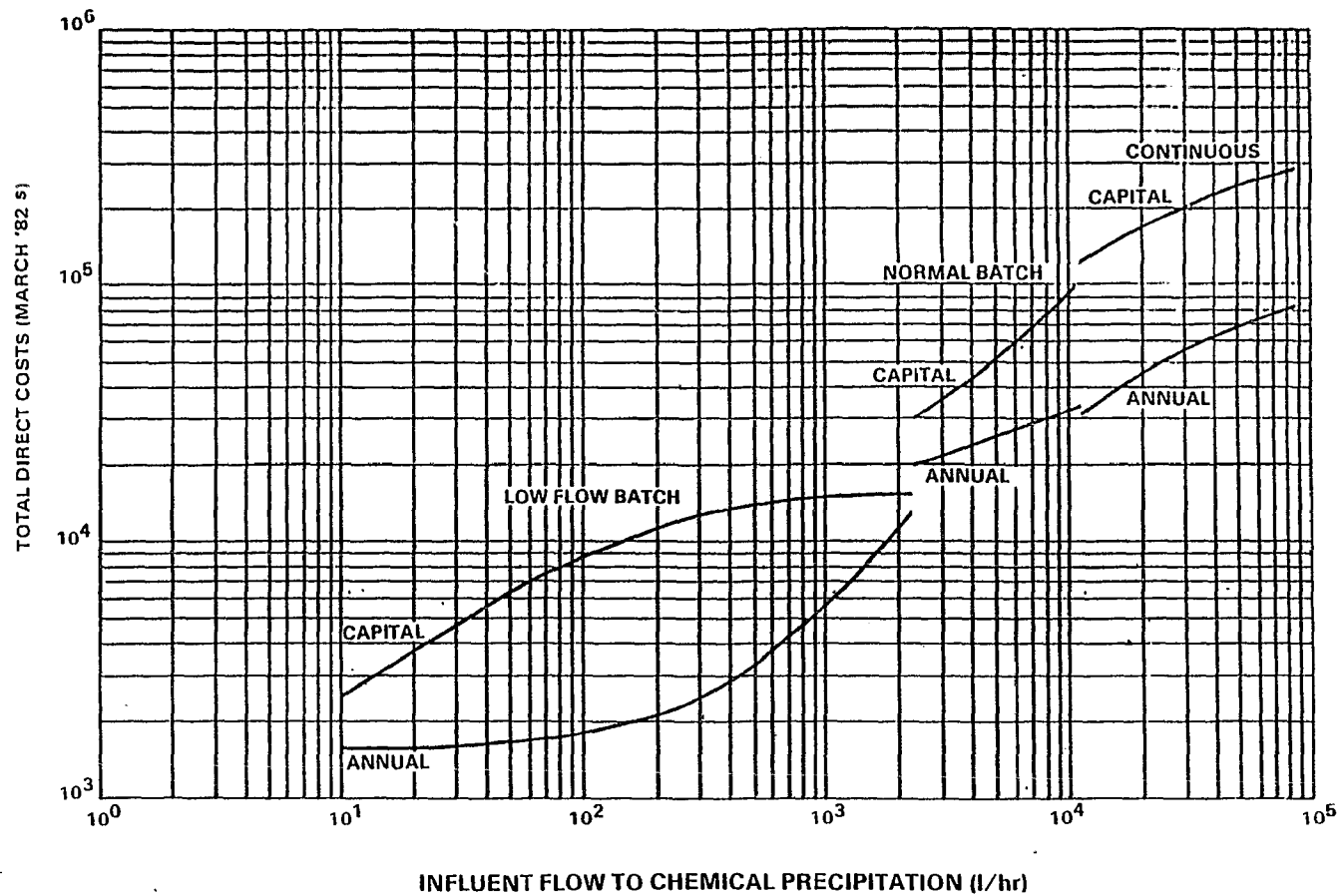

Figure VIII-16

CAPITAL AND ANNUAL COSTS OF CHEMICAL PRECIPITATION

1547

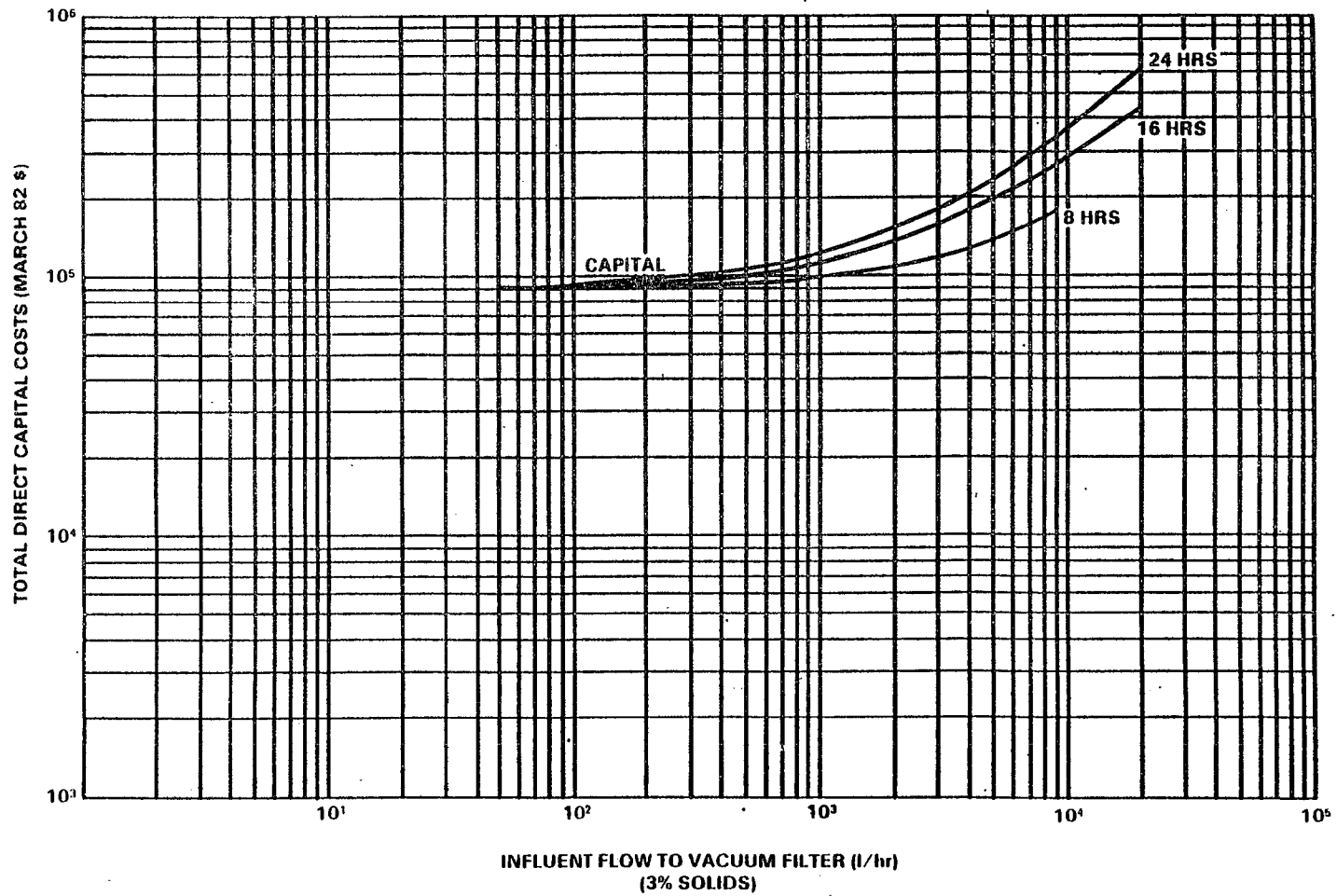

Figure VIII-17

CAPITAL COSTS FOR CARBON STEEL VACUUM FILTERS

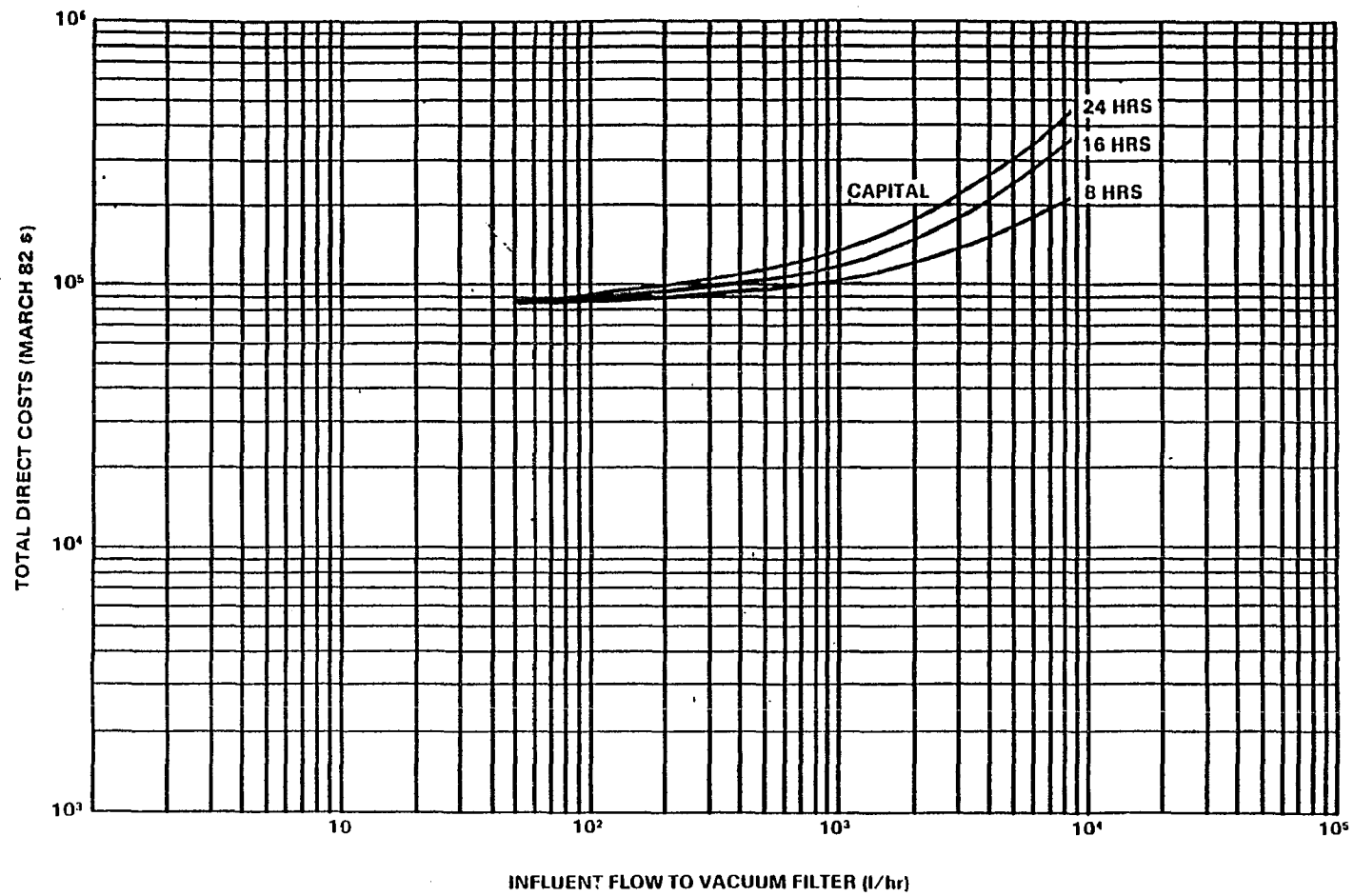
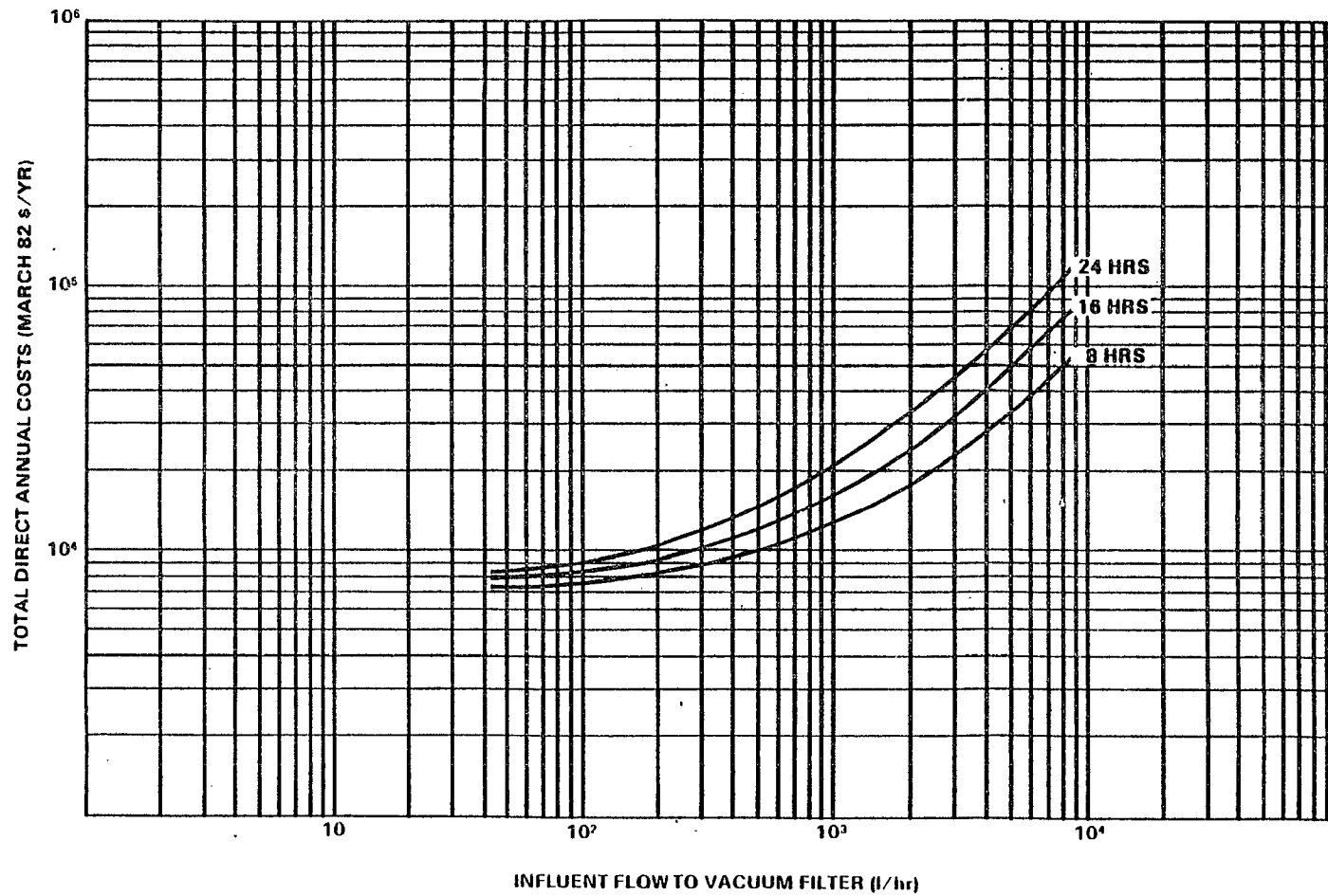

Figure VIII-18
CAPITAL COSTS FOR STAINLESS STEEL VACUUM FILTERS



NOTE: RESULT MUST BE MULTIPLIED BY $DPY/365$

Figure VIII-19
ANNUAL COSTS FOR VACUUM FILTERS

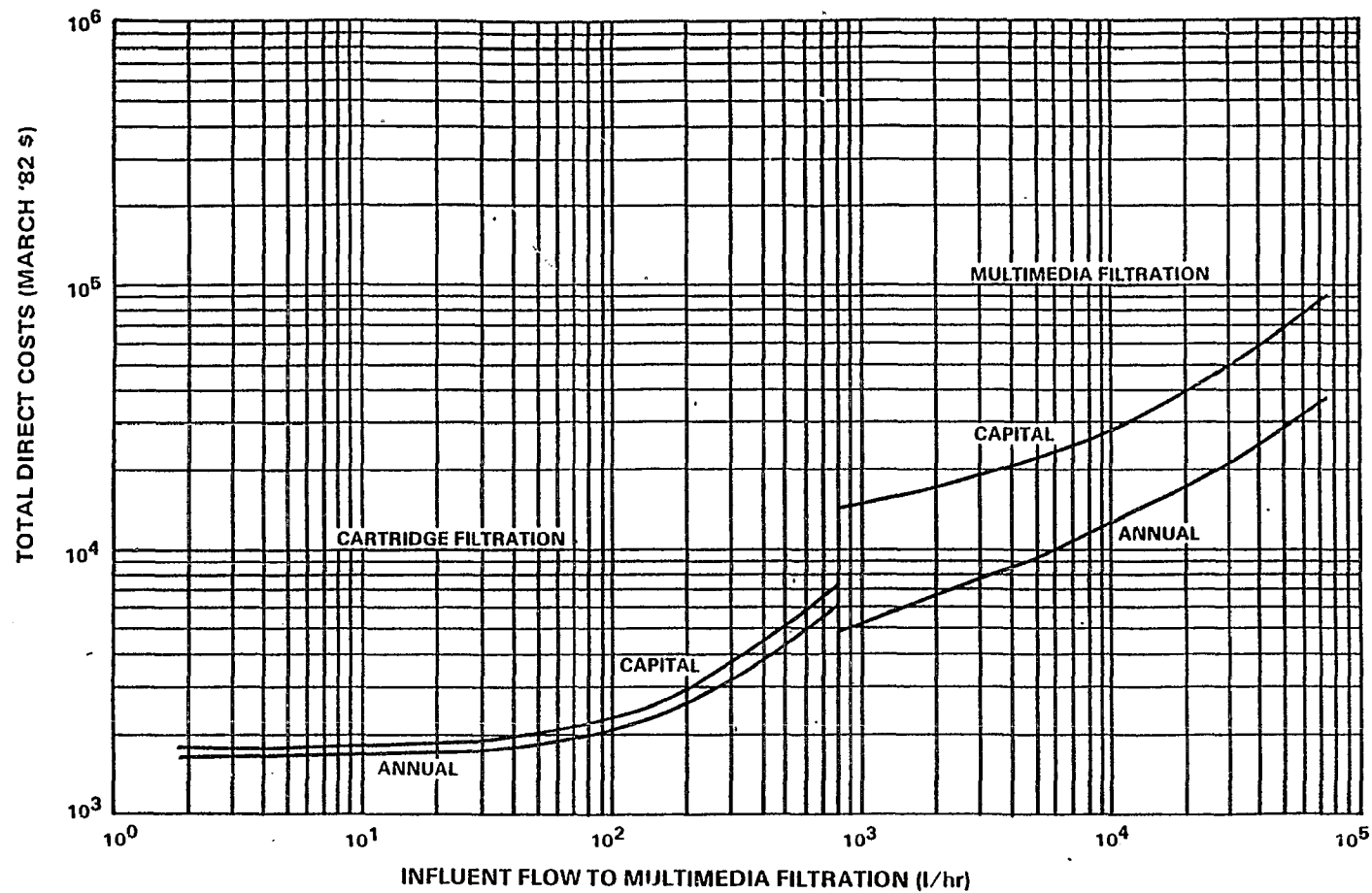

Figure VIII-20

CAPITAL AND ANNUAL COSTS FOR MULTIMEDIA AND CARTRIDGE FILTRATION

1551

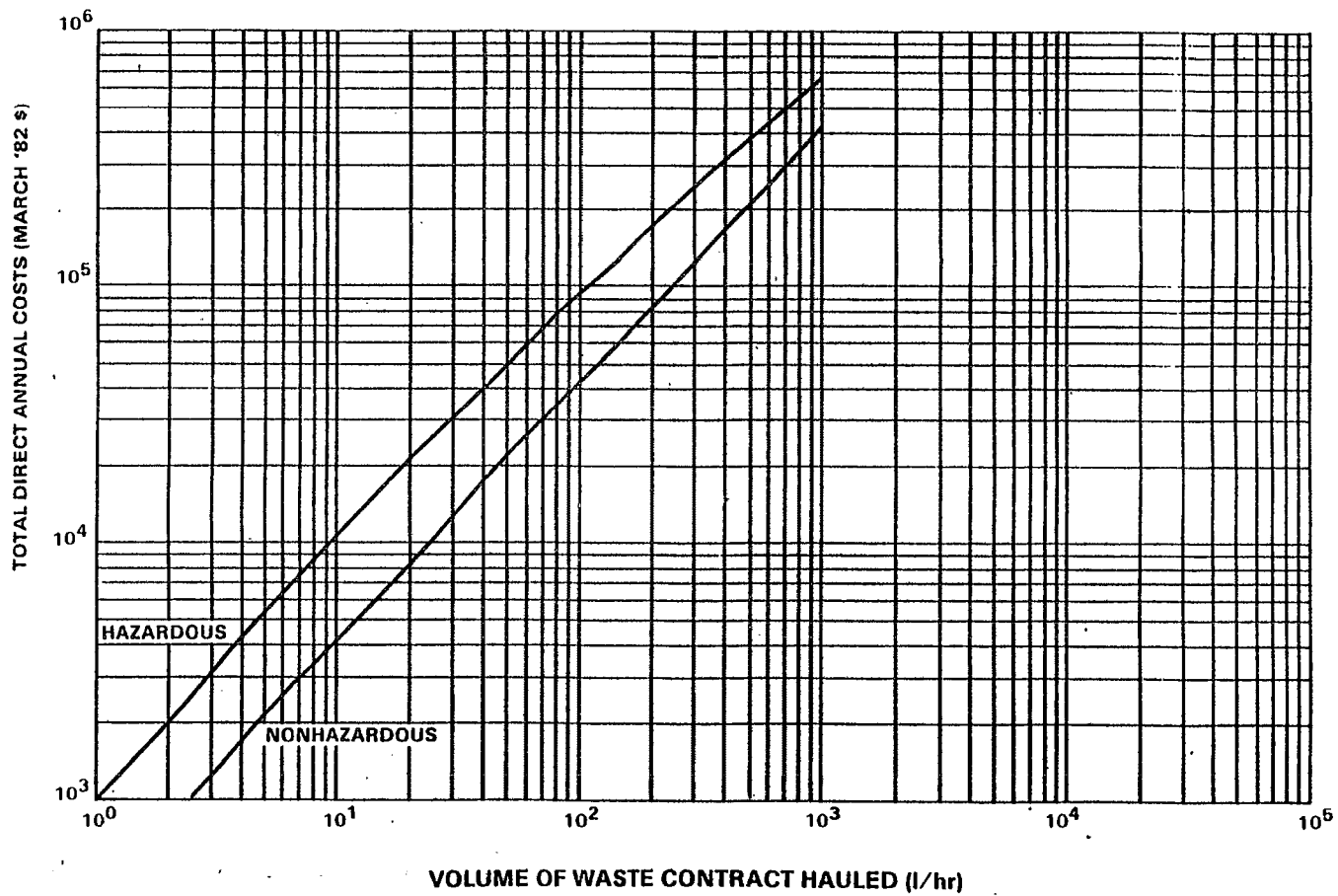

Figure VIII-21

ANNUAL COSTS FOR CONTRACT HAULING

SECTION IX

BEST PRACTICABLE CONTROL TECHNOLOGY CURRENTLY AVAILABLE

This section defines the effluent characteristics attainable through the application of best practicable control technology currently available (BPT), Section 301(b)(1)(A). BPT reflects the average of the best existing performance by plants of various sizes, ages, and manufacturing processes within the nonferrous metals forming category.

The factors considered in identifying BPT include the total cost of applying the technology in relation to the effluent reduction benefits from such application, the age of equipment and facilities involved, the manufacturing processes employed, nonwater quality environmental impacts (including energy requirements), and other factors the Administrator considers appropriate. In general, the BPT level represents the average of the best existing performances of plants of various ages, sizes, processes, or other common characteristics. Where existing performance is uniformly inadequate, BPT may be transferred from a different subcategory or category. Limitations based on transfer of technology are supported by a rationale concluding that the technology is, indeed, transferable, and a reasonable prediction that it will be capable of achieving the prescribed effluent limits. See *Tanner's Council of America v. Train*, 540 F.2d 1188 (4th Cir. 1976). BPT focuses on end-of-pipe treatment rather than process changes or internal controls, except where such practices are common industry practice.

TECHNICAL APPROACH TO BPT

The Agency studied the nonferrous metals forming category to identify the manufacturing processes used and wastewaters generated during nonferrous metals forming. Information was collected from industry using data collection portfolios, and wastewaters from specific plants were sampled and analyzed. The Agency used these data to subcategorize the category and determine what constitutes an appropriate BPT. The factors which were considered in establishing subcategories are discussed fully in Section IV. Nonwater quality impacts and energy requirements are considered in Section VIII.

The category has been subcategorized, for the purpose of regulation, on the basis of metal type formed. Each subcategory is further divided into specific wastewater sources associated with specific manufacturing operations. The regulation establishes pollutant discharge limitations for each source of process wastewater identified within the subcategory. This approach to regulation is referred to as the building block approach with each waste stream being a building block. Compliance with the regulation is determined on an overall plant basis rather than for individual building blocks. The building block approach is

especially useful for this category since many nonferrous metals forming plants generate wastewater from more than one operation. In addition, a few plants generate wastewater from forming more than one metal type, i.e., from operations associated with more than one subcategory. Since the regulation uses the building block approach, permit writers can develop permits which are specific to each individual plant and which reflect the types of metals formed and wastewater sources present at the plant.

In making technical assessments of data, reviewing manufacturing processes, and evaluating wastewater treatment technology options, both indirect and direct dischargers have been considered as a single group. An examination of plants and processes did not indicate any process differences based on the type of discharge, whether it be direct or indirect. Consequently, the calculation of BPT regulatory flows included production normalized flows from both direct and indirect dischargers.

Oil and grease, suspended solids, priority and nonconventional metals, and other nonconventional pollutants are present in significant concentrations in wastewater produced by forming operations (rolling, drawing, extruding, forging, cladding, tube reducing, metal powder production and powder metallurgy) and by operations associated with metal forming (casting, heat treatment, surface treatment, alkaline cleaning, solvent degreasing, sawing, grinding, tumbling, burnishing, and product testing). Although the specific priority and nonconventional metals present will vary from subcategory to subcategory, the Agency believes that one treatment technology with preliminary treatment, where necessary, is an appropriate basis for BPT effluent limitations for all subcategories. Wastewater treatment performance data show that the treatment scheme detailed below will remove all pollutants present in significant concentrations to an acceptable level.

BPT for the nonferrous metals forming category is based on common treatment of combined wastewater streams. For the most part, nonferrous metals forming plants with existing treatment-in-place combine waste streams in a common treatment system. The general treatment scheme for BPT is to apply oil skimming technology to remove oil and grease, followed or combined with lime and settle technology to remove metals and solids from the combined wastewaters. Separate preliminary treatment steps for chromium reduction, emulsion breaking, cyanide removal, and ammonia removal are utilized when necessary. Iron coprecipitation is added to the treatment train when necessary to remove the nonconventional pollutant molybdenum. The BPT treatment effectiveness concentrations are based on the performance of these preliminary treatment steps (when necessary) and chemical precipitation and sedimentation (lime and settle) when applied to a broad range of metal-bearing wastewater. The BPT treatment train varies somewhat between subcategories to take into account treatment of hexavalent chromium, emulsified oils, cyanide, ammonia, and molybdenum. Tables IX-1 through IX-10 summarize for each subcategory the waste streams which may need preliminary treatment

prior to combined wastewater treatment. The basis for performance of these treatment technologies is set forth in substantial detail in Section VII.

For each of the subcategories, a specific approach was followed for the development of BPT mass limitations. To account for production and flow variability from plant to plant, a unit of production or production normalizing parameter (PNP) was determined for each operation which could then be related to the flow from the operation to determine a production normalized flow. As discussed in Section IV, the PNP for the nonferrous metals forming category is off-metric ton (the metric tons of metal removed from a forming operation or associated operation at the end of a process cycle), with one exception. Laundry washwater in the uranium forming subcategory is normalized to employee-day.

Each subcategory was analyzed to determine: (1) which operations included generated wastewater, (2) specific flow rates generated, and (3) specific production normalized flows for each operation. The normalized flows were then analyzed to determine which flow was to be used as the basis for BPT mass limitations for that operation. The selected flow (referred to as the BPT regulatory flow), reflects the water use controls which are common practices within the industry. The overall effectiveness of end-of-pipe treatment for the removal of wastewater pollutants is improved by the application of water flow controls within the process to limit the volume of wastewater requiring treatment. However, the controls or in-process technologies recommended under BPT include only those measures which are commonly practiced within the category or subcategory. Except for recycle of lubricating emulsions, most plants in this category do not have flow reduction in place. Therefore, flow reduction is not generally included as part of the BPT technology.

In general, the BPT regulatory flows are based on the average of all applicable data. However, for some waste streams with a large range of production normalized flows the median was used as the basis for the BPT regulatory flow. The Agency believes the median is more representative of the current typical water use for these waste streams than the average. Plants with existing flows above the average or median may have to implement some method of flow reduction to achieve the BPT limitations. In most cases, this will involve improving house-keeping practices, better maintenance to limit water leakage, or reducing excess flow by turning down a flow valve. It is not believed that these modifications will generate any significant costs for the plants. In fact, these plants should save money by reducing water consumption.

Pollutant discharge limitations for this category are expressed as mass loadings, i.e., allowable mass of pollutant discharge per off-kilogram of production (mg/off-kg). Mass loadings were calculated for each operation (building block) within each subcategory. The mass loadings were calculated by multiplying the BPT regulatory flow (l/off-kg) for the operation by the

effluent concentration achievable by the BPT treatment technology (mg/l). Table VII-21 presents the effluent concentrations achievable by the BPT model treatment train for the pollutants regulated in each subcategory. These concentrations are based on the performance of chemical precipitation and sedimentation (lime and settle) when applied to a broad range of metal-bearing wastewaters, with preliminary treatment, when necessary. The derivation of these achievable effluent concentrations is discussed in substantial detail in Section VII.

In deriving mass limitations from the BPT model treatment technology, the Agency assumed that all wastewaters generated within a subcategory were combined for treatment in a single or common treatment system for that subcategory, even though flow and sometimes pollutant characteristics of process wastewater streams vary within the subcategory. A disadvantage of common treatment is that some loss in pollutant removal effectiveness will result where waste streams containing specific pollutants at treatable levels are combined with other streams in which these same pollutants are absent or present at very low concentrations. Under these circumstances a plant may prefer to segregate these waste streams and bypass treatment. Since treatment systems considered under BPT are primarily for metals, oil and grease, and suspended solids removal, and many existing plants usually had one common treatment system in place for these pollutants, it is reasonable to assume a common treatment system for each subcategory to calculate the system's cost and effectiveness.

Regulated Pollutant Parameters

In Section VI, priority pollutant parameters are selected for consideration for regulation in the nonferrous metals forming subcategories because of their frequent presence at treatable concentrations in raw wastewaters. The selected pollutant parameters include total suspended solids, oil and grease, and pH which are regulated in every subcategory. Priority metals are also regulated in every subcategory, though the specific metals regulated vary. Nonconventional pollutants selected for regulation also vary with different subcategories. Nonconventional pollutants regulated in one or more subcategories include ammonia, fluoride, and molybdenum. The basis for regulating total suspended solids, oil and grease, and pH is discussed below. Selection of priority and nonconventional pollutants for regulation will be included in the individual subcategory discussions presented later in this section since regulated priority metal and nonconventional pollutants vary with the different subcategories.

Total suspended solids, in addition to being present at high concentrations in raw wastewater from nonferrous metals forming operations, is an important control parameter for metals removal in chemical precipitation and settling treatment systems. Metals are precipitated as insoluble metal hydroxides, and effective solids removal is required in order to ensure reduced levels of regulated metals in the treatment system effluent. Therefore,

total suspended solids are regulated as a conventional pollutant to be removed from the wastewater prior to discharge.

Oil and grease is regulated under BPT since a number of nonferrous metals forming operations (i.e., rolling, sawing, grinding, drawing, extrusion) generate emulsified wastewater streams which may be discharged. In addition, the equipment used to form nonferrous metals use significant quantities of oil as machinery lubricant or hydraulic fluid, these oils frequently get into the process wastewater as tramp oils.

The importance of pH control is documented in Section VII and its importance in metals removal technology cannot be overemphasized. Even small excursions from the optimum pH level can result in less than optimum functioning of the treatment system and inability to achieve specified results. The optimum operating level for removal of most metals is usually pH 8.8 to 9.3. However, nickel, cadmium, and silver require higher pH for optimal removal. To allow a reasonable operating margin and to preclude the need for final pH adjustment, the effluent pH is specified to be within the range of 7.5 to 10.

The remainder of this section describes the development of BPT mass loadings for each subcategory. The development of BPT regulatory flows for each operation in each subcategory is presented in detail. The pollutants selected and excluded from regulation, and the cost and benefit of the regulation at BPT are also presented.

LEAD-TIN-BISMUTH FORMING SUBCATEGORY

Production Operations and Discharge Flows

Production operations that generate wastewater in the lead-tin-bismuth forming subcategory include rolling, drawing, extrusion, swaging, continuous strip casting, semi-continuous ingot casting, shot casting, shot forming, alkaline cleaning, and degreasing. Water use practices, wastewater streams, and wastewater discharge flows from these operations were discussed in Section V. This information provided the basis for development of the BPT regulatory flow allowances summarized in Table IX-11. The following paragraphs discuss the basis for the BPT flow allowances for each waste stream.

Rolling

Rolling is performed at 26 plants in this subcategory. The following information is available from these plants:

Number of plants and operations using emulsion lubricant: 7
Number of plants and operations using soap solution lubricant: 1.

No lubricants were reported to be used in over 15 rolling operations.

Lead-Tin-Bismuth Rolling Spent Emulsions. All of the operations using rolling emulsions completely recycle the emulsions and periodically batch dump them when they become spent. The spent emulsion from one operation is incinerated; the spent emulsion from one operation is applied to land; and the spent emulsion from five operations is contract hauled. Spent emulsions which are contract hauled off-site typically receive some type of emulsion breaking (chemical or thermal) and oil skimming treatment. After this treatment the water fraction is discharged and the oil fraction is either sent to a reclaiming operation or landfilled directly. Since spent emulsions are often treated on-site and the water discharged (with the oil fraction contract hauled), EPA is allowing a discharge for this waste stream. The BPT discharge allowance is 23.4 l/kg (5.60 gal/ton), the average of the six reported production normalized discharge flows.

Lead-Tin-Bismuth Rolling Spent Soap Solutions. The one operation using rolling soap solutions applies and discharges 43.0 l/kg (10.3 gal/ton). Therefore, the BPT discharge allowance is 43.0 l/kg (10.3 gal/ton).

Drawing

Drawing is performed at 26 plants in the lead-tin-bismuth forming subcategory. The following information is available from these plants:

Number of plants and operations using neat oil lubricant: 3
Number of plants and operations using emulsion lubricant: 6 plants, 8 operations.
Number of plants and operations using soap solution lubricant-coolant: 2.

No lubricants were reported to be used in over five operations.

Lead-Tin-Bismuth Drawing Spent Neat Oils. None of the three operations using neat oils discharge any of the lubricant. Two achieve zero discharge through total recycle and one contract hauls batches of the spent neat oils periodically. Since neat oils are pure oil streams, with no water fraction, it is better to remove the oil directly by contract hauling and not to discharge the stream than to commingle the oil with water streams and then remove it later using an oil-water separation process. Therefore, this waste stream should not be discharged.

Lead-Tin-Bismuth Drawing Spent Emulsions. Six of the eight operations using emulsion lubricants do not discharge spent emulsion. Two operations periodically discharge the spent emulsion. Information sufficient to calculate production normalized discharge flows was available for only one of the operations which discharge the spent emulsion. Four of the six remaining operations achieve zero discharge through 100 percent recycle of the emulsions with drag-out on the product surface being the only loss, while two operations report contract hauling the spent emulsions after periodic batch dumps. Information sufficient to

calculate production normalized discharge flows was not available for the operations which contract haul the spent emulsion. Spent emulsions which are contract hauled off-site typically receive some type of emulsion breaking (chemical or thermal) and oil skimming treatment. After this treatment, the water fraction is discharged and the oil fraction is either sent to a reclaiming operation or landfilled directly. Since spent emulsions are often treated on-site and the water discharged (with the oil fraction contract hauled), EPA is allowing a discharge for this waste stream. The BPT discharge allowance is 26.3 l/kg (6.30 gal/ton), the only reported non-zero production normalized discharge flow.

Lead-Tin-Bismuth Drawing Spent Soap Solutions. One of the two operations using soap solutions as a drawing lubricant periodically discharges the solution. The other operation achieves zero discharge through total recycle. The BPT discharge allowance is 7.46 l/kg (1.79 gal/ton), the one reported non-zero production normalized discharge flow.

Extrusion

Extrusion is performed at 43 plants in this subcategory. The following information is available from these plants:

Number of plants and operations using contact cooling water: 14 plants, 17 operations
Number of plants and operations reporting hydraulic fluid leakage: 2.
None of the plants reported using water-based lubricants in extrusion operations.

Lead-Tin-Bismuth Extrusion Press and Solution Heat Treatment Contact Cooling Water. As discussed in Section III, contact cooling water is used in extrusion operations, either by spraying water onto the metal as it emerges from the die or press, or by direct quenching in a contact water bath. Three operations were reported to achieve zero discharge by 100 percent recycle and one operation reported achieving zero discharge by 100 percent recycle with periodic contract hauling. A discharge with no recycle is reported for 11 extrusion operations. No water use data were reported for one of these operations. A discharge with an unknown recycle rate was reported by two plants. The BPT discharge allowance is the average of the 10 reported non-zero production normalized discharge flows, 1,440 l/kg (346 gal/ton). Production normalized discharge flows for the two operations with unknown recycle ratios were not included in the average.

Lead-Tin-Bismuth Extrusion Press Hydraulic Fluid Leakage. One of the 43 plants with extrusion operations discharges hydraulic fluid leakage from an extrusion press. Another plant reported 100 percent recycle of hydraulic fluid leakage. The Agency believes that other plants in the lead-tin-bismuth forming subcategory use similar extrusion presses and may have leakage. The BPT dis-

charge allowance is based on the one reported production normalized discharge flow, 55.0 l/kg (13.2 gal/ton).

Swaging

Swaging is performed at five plants in this subcategory. Emulsions are used for lubrication in a total of four operations at three plants. Two plants did not report the use of lubricants in swaging operations.

Lead-Tin-Bismuth Swaging Spent Emulsions. Three of the four swaging operations which use lubricants achieve zero discharge by 100 percent recycle, with evaporation and drag-out on the product surface being the only losses. Spent emulsion is batch discharged from the other operation. Spent emulsions which are contract hauled off-site typically receive some type of emulsion breaking (chemical or thermal) and oil skimming treatment. After this treatment, the water fraction is discharged and the oil fraction is either sent to a reclaiming operation or landfilled directly. Since the spent emulsions are often treated on-site and the water discharged (with the oil fraction contract hauled) by plants in this category and other categories, EPA is allowing a discharge for this waste stream. The BPT discharge allowance is 1.77 l/kg (0.424 gal/ton), the only reported non-zero production normalized discharge flow.

Casting

The following information was reported on casting operations in this subcategory:

Total number of plants: 34

Number of plants and operations with continuous strip casting: 6

Number using contact cooling water: 5

Number of plants and operations using semi-continuous ingot casting: 3

Number using contact cooling water: 3

Number of plants and operations with shot casting: 3 Number using contact cooling water: 3

Number of plants and operations with continuous wheel casting: 1

Number using contact cooling water: 0

Number of plants and operations with continuous sheet casting: 1 Number using contact cooling water: 0

Number of plants and operations with stationary casting (also referred to as chill casting and mold casting): 26 plants, 28 operations

Number using contact cooling water: 0

Number of plants and operations with shot pressing: 2 Number

Lead-Tin-Bismuth Continuous Strip Casting Contact Cooling Water. In five of the six continuous strip casting operations, the contact cooling water is completely recycled and periodically batch dumped. One operation uses only noncontact cooling water. The BPT discharge allowance is the average of the five reported production normalized discharge flows, 1.00 l/kg (0.240 gal/ton).

Lead-Tin-Bismuth Semi-Continuous Ingot Casting Contact Cooling Water. Water use and discharge data were reported for only one operation. Contact cooling water from this operation is discharged on a once-through basis. Based on the one reported production normalized water use, the BPT discharge allowance is 29.4 l/kg (7.04 gal/ton).

Lead-Tin-Bismuth Shot Casting Contact Cooling Water. In two of the three operations, the contact cooling water is periodically dumped. The average of the two reported production normalized discharge flows is the BPT discharge allowance, 37.3 l/kg (8.95 gal/ton).

Lead-Tin-Bismuth Shot Forming Wet Air Pollution Control Blowdown. One plant provided information on shot forming. It reported using a wet scrubber to control air pollution from the lead polishing and drying unit operations of a shot forming line. The scrubber water is discharged on a once-through basis. The BPT discharge allowance is the production normalized water use of the one plant, 588 l/kg (141 gal/ton).

Alkaline Cleaning

Four plants provided information on six alkaline cleaning operations.

Lead-Tin-Bismuth Alkaline Cleaning Spent Baths. Spent baths are discharged from six alkaline cleaning operations. The BPT discharge allowance is 120 l/kg (28.7 gal/ton), the average of the six production normalized discharge flows.

Lead-Tin-Bismuth Alkaline Cleaning Rinse. Four alkaline cleaning operations discharge rinse with no recycle. The BPT discharge allowance is 2,360 l/kg (565 gal/ton), the average of the four production normalized water use from the four operations.

Degreasing

Lead-Tin-Bismuth Degreasing Spent Solvents. A small number of surveyed plants with solvent degreasing operations have process wastewater streams associated with the operation. Because most plants practice solvent degreasing without wastewater discharge, the Agency believes zero discharge of wastewater is the appropriate discharge limitation.

Regulated Pollutants

The priority pollutants considered for regulation under BPT are listed in Section VI, along with an explanation of why they were considered. The only priority pollutants considered for regulation are antimony and lead. These two pollutants have been selected for regulation under BPT along with total suspended solids, oil and grease, and pH. The basis for regulating total suspended solids, oil and grease, and pH under BPT was discussed earlier in this section. The basis for regulating antimony and lead is discussed below.

Antimony has been selected for regulation under BPT since it is frequently found at treatable concentrations in process wastewater streams from this subcategory. Treatable antimony concentrations were found in shot casting contact cooling water, alkaline cleaning spent baths, and alkaline cleaning rinse.

Lead has been selected for regulation under BPT since it was found at treatable concentrations in all process wastewater samples analyzed from this subcategory and because it is the metal being processed. The Agency believes that when antimony and lead are controlled with the application of lime and settle technology, control of other priority metals which may be present in process wastewater is assured.

Treatment Train

The BPT model treatment train for the lead-tin-bismuth forming subcategory consists of preliminary treatment when necessary, specifically emulsion breaking and oil skimming. The effluent from preliminary treatment is combined with other wastewater for common treatment by oil skimming and lime and settle. Waste streams potentially needing preliminary chemical emulsion breaking are listed in Table IX-1. Figure IX-1 presents a schematic of the general BPT treatment train for the nonferrous metals forming category.

Effluent Limitations

The pollutant mass discharge limitations (milligrams of pollutant per off-kilogram of PNP) were calculated by multiplying the BPT regulatory flows summarized in Table IX-11 (l/kg) by the concentration achievable by the BPT model treatment system summarized in Table VII-21 (mg/l) for each pollutant parameter considered for regulation at BPT ($l/off\text{-}kkg \times mg/l \times kkg/l,000 \text{ kg} = mg/off\text{-}kg$). The results of this computation for all waste streams and regulated pollutants in the lead-tin-bismuth forming subcategory are summarized in Table IX-13. This limitation table lists all the pollutants which were considered for regulation; those specifically regulated are marked with an asterisk.

Costs and Benefits

In establishing BPT, EPA considered the cost of treatment and control and the pollutant reduction benefits to evaluate economic achievability. As shown in Table X-3 (page xxxx), the application of BPT to the total lead-tin-bismuth forming subcategory will remove approximately 5,730 kg/yr (12,610 lbs/yr) of pollutants including 235 kg/yr (520 lbs/yr) of toxic pollutants. As shown in Table X-13 (page xxxx), the application of BPT to direct dischargers only will remove approximately 1,450 kg/yr (3,190 lbs/yr) of pollutants including 45 kg/yr (100 lbs/yr) of toxic pollutants. Since there are only three direct discharge plants in this subcategory, total subcategory capital and annual costs will not be reported in this document in order to protect confidentiality claims. The Agency concludes that these pollutant removals justify the costs incurred by plants in this subcategory.

MAGNESIUM FORMING SUBCATEGORY

Production Operations and Discharge Flows

Production operations that generate wastewater in the magnesium forming subcategory include rolling, forging, direct chill casting, surface treatment, sawing, grinding, and degreasing. Water use practices, wastewater streams, and wastewater discharge flows from these operations were discussed in Section V. This information provided the basis for development of the BPT regulatory flow allowances summarized in Table IX-13. The following paragraphs discuss the basis for the BPT flow allowances for each waste stream.

Rolling

The following information was reported on rolling operations in this subcategory:

Number of plants: 1

Number of operations using emulsion lubricant: 2.

Magnesium Rolling Spent Emulsions. The emulsions from both operations are batch dumped and hauled off-site by a waste contractor. The quantity of emulsion hauled was not reported for either operation. Spent emulsions which are contract hauled off-site typically receive some type of emulsion breaking (chemical or thermal) and oil skimming treatment. After this treatment, the water fraction is discharged and the oil fraction is either sent to a reclaiming operation or landfilled directly. Since spent emulsions are often treated on-site and the water discharged (with the oil fraction contract hauled), EPA is allowing a discharge for this waste stream. The BPT flow has been set equal to the BPT flow given for spent aluminum rolling emulsions, 74.6 l/kg (17.9 gal/ton). The Agency believes that, because aluminum and magnesium have similar melting points and

other metallurgical properties, similar amounts of waste emulsion will be generated in rolling the two metals.

Forging

The following information was reported on forging operations in this subcategory:

Number of plants: 4
Number of plants and operations using lubricants: 3 plants, 4 operations
Number of plants and operations using contact cooling water: 3 plants, 4 operations
Number of equipment cleaning operations: 2.

Magnesium Forging Spent Lubricants. The only loss of lubricant from any of the four operations is through drag-out on the product surface. Consequently, there is no BPT discharge allowance for forming spent lubricants. Since, magnesium forging lubricants are not water based, they should be kept separate from other process wastewater streams and therefore, should not be discharged.

Magnesium Forging Contact Cooling Water. One operation has no water discharge due to 100 percent recycle and evaporation. The BPT flow is the average of the two reported non-zero production normalized discharge flows, 2,890 l/kg (693 gal/ton).

Magnesium Forging Equipment Cleaning Wastewater. One plant reported using water to clean equipment in its two forging operations. The equipment cleaning wastewater from these operations is not recycled. The BPT discharge allowance, based on the average production normalized water use from the two operations, is 39.9 l/kg (9.59 gal/ton).

Casting

Magnesium Direct Chill Casting Contact Cooling Water. One nonferrous metals forming plant casts magnesium by the direct chill method. The cooling water used in this operation is completely recycled. Another plant has a direct chill casting operation which is an integral part of a magnesium smelting and refining (nonferrous metals manufacturing phase II) operation. Once-through contact cooling water is discharged from this operation. The BPT flow of 3,950 l/kg (947 gal/ton) is based on the production normalized water use for the nonferrous metals manufacturing operation.

Surface Treatment

Three plants supplied information on magnesium surface treatment operations. Information was provided on the discharge of nine surface treatment baths and on seven surface treatment rinse operations.

Magnesium Surface Treatment Spent Baths. An unreported amount of wastewater is contract hauled from two of the operations. Wastewater discharge flows were reported for three of the remaining seven operations. The BPT discharge allowance is the average of production normalized discharge flow from three operations, 466 l/kkg (112 gal/ton).

Magnesium Surface Treatment Rinse. One operation uses 100 percent recycle with a periodic batch discharge of rinse. Of the remaining six operations, two operations consist of single stage overflow rinses with no recycle, two operations consist of a spray rinse followed by an overflow rinse with no recycle, and two operations consist of non-cascade sequential rinsing stages. The average of the seven production normalized discharge flows is the BPT flow, 18,900 l/kkg (4,520 gal/ton).

Sawing or Grinding

The use of emulsion lubricants was reported for a total of two operations at two plants.

Magnesium Sawing or Grinding Spent Emulsions. One operation achieves zero discharge by 100 percent recycle. Some emulsion from this operation is lost due to evaporation and drag-out on the product. In the other operation, the emulsion is recycled with periodic batch discharges contract hauled to treatment and disposal off-site. Since spent emulsions are often treated on-site and the water discharged (with the oil fraction contract hauled), EPA is allowing a discharge for this waste stream. The BPT allowance has been set equal to the production normalized discharge flow of contract hauled emulsion, 19.5 l/kkg (4.68 gal/ton).

Degreasing

Magnesium Degreasing Spent Solvents. Only a small number of surveyed plants with solvent degreasing operations have process wastewater streams associated with the operation. Because most plants practice solvent degreasing without wastewater discharge, the Agency believes zero discharge of wastewater is an appropriate discharge limitation.

Wet Air Pollution Control

Magnesium Wet Air Pollution Control Blowdown. Blowdown from the wet air pollution control devices used to control air pollution from forging, sanding and repairing, and surface treatment is included under this building block. The Agency believes that the water requirements for scrubbing air emissions from these areas are similar. Three of the four operations practice 90 percent recycle or greater of the scrubber liquor while no recycle is used in the remaining operation. Flow reduction is considered BPT technology for wet air pollution control blowdown since three of the four plants practice 90 percent or greater recycle.

Therefore, the BPT flow of 619 l/kg (148 gal/ton) is based on the average production normalized discharge flow from the operations with 90 percent or greater recycle.

Regulated Pollutants

The priority pollutants considered for regulation under BPT are listed in Section VI along with an explanation of why they were considered. The only priority pollutants considered for regulation in this subcategory are chromium and zinc. Chromium and zinc are selected for regulation under BPT along with the nonconventional pollutants ammonia and fluoride and the conventional pollutant parameters total suspended solids, oil and grease, and pH. The nonconventional pollutant, magnesium, is not specifically regulated under BPT for the reasons given in Section X. The basis for regulating total suspended solids, oil and grease, and pH under BPT was discussed earlier in this section. The basis for regulating total chromium, zinc, ammonia, and fluoride is discussed below.

Total chromium is regulated since it includes both the hexavalent and trivalent forms of chromium. Only the trivalent form is removed by the lime and settle technology. Therefore, the hexavalent form must be reduced by preliminary chromium reduction treatment in order to meet the limitations on chromium in this subcategory. Treatable chromium concentrations were found in samples from surface treatment baths and rinses. Therefore, regulation of total chromium is appropriate for this subcategory.

Zinc has been selected for regulation under BPT since it and chromium are the predominant priority metals present in magnesium forming wastewaters. The Agency believes that when these parameters are controlled with the application of lime and settle technology with preliminary treatment when needed, control of the other toxic metals is assured.

Ammonia may be present at treatable concentrations in surface treatment spent baths and surface treatment rinse. Therefore, ammonia is selected for regulation in the magnesium forming subcategory. Preliminary ammonia steam stripping treatment is needed to remove this pollutant from these wastewaters.

Fluoride may also be present at treatable concentrations in surface treatment baths and surface treatment rinse. Therefore, fluoride is selected for regulation in this subcategory.

Treatment Train

The BPT model treatment train for the magnesium forming subcategory consists of preliminary treatment when necessary, specifically emulsion breaking and oil skimming, chromium reduction and ammonia steam stripping. The effluent from preliminary treatment is combined with other wastewater for common treatment by oil skimming and lime and settle. Waste streams potentially needing preliminary treatment are listed in Table IX-2. Figure IX-1

presents a schematic of the general BPT treatment train for the nonferrous metals forming category.

Effluent Limitations

The pollutant mass discharge limitations (milligrams of pollutant per off-kilogram of PNP) were calculated by multiplying the BPT regulatory flows summarized in Table IX-13 (l/kg) by the concentration achievable by the BPT model treatment system summarized in Table VII-21 (mg/l) for each pollutant parameter considered for regulation at BPT ($1/\text{off-kg} \times \text{mg/l} \times 1 \text{ kkg}/1,000 \text{ kg} = \text{mg/off-kg}$). The results of this computation for all waste streams and regulated pollutants as well as magnesium in the magnesium forming subcategory are summarized in Table IX-14. Although no limitations have been established for magnesium, Table IX-14 includes magnesium mass discharge limitations attainable using the BPT model technology. These limitations are presented for the guidance of permit writers. Only daily maximum limitations are presented, based on the detection limit for magnesium (0.10 mg/l), because lime and settle treatment was determined to remove magnesium to below the level of analytical quantification. The attainable monthly average discharge is expected to be lower than the one day maximum limitation; but since it would be impossible to monitor for compliance with a lower level, no monthly average has been presented.

The limitation table lists all the pollutants which were considered for regulation; those specifically regulated are marked with an asterisk.

Costs and Benefits

In establishing BPT, EPA considered the cost of treatment and control and the pollutant reduction benefits to evaluate economic achievability. As shown in Table X-4 (page xxxx), the application of BPT to the total magnesium forming subcategory will remove approximately 33,570 kg/yr (73,855 lbs/yr) of pollutants including 16,900 kg/yr (37,180 lbs/yr) of toxic pollutants. As shown in Table X-1 (page xxxx), the corresponding capital and annual costs (1982 dollars) for this removal are \$218,000 and \$146,000 per year, respectively. As shown in Table X-14 (page xxxx), the application of BPT to direct dischargers only will remove approximately 28,615 kg/yr (62,950 lbs/yr) of pollutants including 14,790 kg/yr (32,540 lbs/yr) of toxic pollutants. As shown in Table X-2 (page xxxx), the corresponding capital and annual costs (1982 dollars) for this removal are \$148,200 and \$95,700 per year, respectively. The Agency concludes that these pollutant removals justify the costs incurred by the plants in this subcategory.

NICKEL-COBALT FORMING SUBCATEGORY

Production Operations and Discharge Flows

Production operations which generate process wastewater in the nickel-cobalt forming subcategory include rolling, tube reducing, drawing, extrusion, forging, metal powder production, stationary casting, vacuum melting, heat treatment, surface treatment, cleaning, sawing, grinding, product testing, and degreasing. Water use practices, wastewater streams and wastewater discharge flows from these operations were discussed in Section V. This information provided the basis for development of the BPT regulatory flow allowances summarized in Table IX-15. The following paragraphs discuss the basis for the BPT flow allowances for each waste stream.

Rolling

Rolling is performed at 30 plants in the nickel-cobalt forming subcategory. The following information is available from these plants:

Number of plants and operations using neat oil lubricant: 5 plants, 6 operations
Number of plants and operations using emulsion lubricant: 5 plants, 7 operations
Number of plants and operations using contact cooling water: 6 plants, 9 operations.
Approximately 15 plants reported no use of lubricants or contact cooling water for their rolling operations.

Nickel-Cobalt Rolling Spent Neat Oils. The neat oils in four of the operations are consumed during the rolling operation, while the neat oils in the other two operations are contract hauled. Since neat oils are pure oil streams, with no water fraction, it is better to remove the oil directly by contract hauling and not to discharge the stream than to commingle the oil with water streams and then remove it later using an oil-water separation process. Consequently, this waste stream should not be discharged.

Nickel-Cobalt Rolling Spent Emulsions. Spent rolling emulsions are either treated on-site or contract hauled for treatment and disposal off-site. Production normalized discharge flows are available for three of the seven rolling operations which use spent emulsions. Spent emulsions from two of these operations are treated on-site while emulsion from the third operation is contract hauled. A BPT discharge allowance of 170 l/kg (40.9 gal/ton) has been established for this stream since spent emulsion is sometimes treated on-site and the water discharged (with the oil fraction contract hauled). The BPT flow is based on the average of the three reported production normalized discharge flows.

Nickel-Cobalt Rolling Contact Cooling Water. Flow information was available for eight of the nine rolling operations which use contact cooling water. Two operations achieve zero discharge by completely recycling the contact cooling water stream. No information regarding the amount of water used in these operations was available. The other operations use widely varying amounts of water for contact cooling. Production normalized water uses for these operations vary from 72.8 to 43,400 l/kg. The BPT flow of 3,770 l/kg (905 gal/ton) is based on the median of the six reported production normalized cooling water uses. The median is believed to be a better representation of the current typical water use for this operation than the average (arithmetic mean) because of the large range of reported production normalized water uses.

Tube Reducing

Three plants reported information on three tube reducing (also referred to as pilgering) operations. Lubricants are used in these operations.

Nickel-Cobalt Tube Reducing Spent Lubricant. There shall be no discharge allowance for the discharge of pollutants from tube reducing spent lubricants if once each month for six consecutive months the facility owner or operator demonstrates the absence of N-nitrosodi-n-propylamine, N-nitrosodimethylamine, and N-nitrosodiphenylamine by sampling and analyzing spent tube reducing lubricants. If the facility complies with this requirement for six months then the frequency of sampling may be reduced to once each quarter. A facility shall be considered in compliance with this requirement if the concentrations of the three nitrosamine compounds does not exceed the analytical quantification levels set forth in 40 CFR Part 136 which are 0.020 mg/l for N-nitrosodiphenylamine, 0.020 for N-nitrosodi-n-propylamine, and 0.050 mg/l for N-nitrosodimethylamine.

Drawing

Drawing is performed at 32 plants in the nickel-cobalt forming subcategory. The following information is available from these plants:

Number of plants and operations using neat oil lubricant: 8 plants, 11 operations

Number of plants and operations using emulsion lubricant: 8 plants, 9 operations.

No lubricants were reported to be used at over 15 plants.

Nickel-Cobalt Drawing Spent Neat Oils. Neat oils from nine of the 11 operations are contract hauled; the only loss of neat oil from one operation is by evaporation and drag-out; no information regarding spent neat oils is available for the other drawing operation which uses a neat oil lubricant. As discussed previously for rolling spent neat oils, it is better to remove the

neat oils directly and not to discharge the stream than to commingle the oil with water streams and then remove it later. Therefore, this waste stream should not be discharged.

Nickel-Cobalt Drawing Spent Emulsions. Spent emulsions from eight of the nine plants reporting the use of emulsion lubricants are periodically contract hauled to treatment and disposal off-site. One operation periodically discharges the spent emulsion. Information sufficient to calculate production normalized discharge flows was available for two of the operations which haul the emulsion and the one which discharges it. As discussed previously for drawing spent emulsions in the lead-tin-bismuth forming subcategory, spent emulsions are often treated on-site and the water discharged (with the oil fraction contract hauled) by plants in this category and other categories. Therefore, the BPT discharge allowance is the average of the three reported production normalized discharge flows, 95.4 l/kg (22.9 gal/ton).

Extrusion

Extrusion is performed at eight plants in this subcategory. The following information is available from these plants:

Number of plants and operations using lubricants: 4
Number of plants and operations using press and solution heat treatment contact cooling water: 2
Number of plants and operations recording hydraulic fluid leakage: 1.

Nickel-Cobalt Extrusion Spent Lubricants. Lubricants are completely recycled in all operations, with the only loss occurring through evaporation and drag-out. The extrusion lubricants which are used are typically neat oils. Since neat oils are pure oil streams, with no water fraction, it is better to remove the oil directly and not to discharge the stream than to commingle the oil with water streams and then remove it later. Therefore, this waste stream should not be discharged.

Nickel-Cobalt Extrusion Press and Solution Heat Treatment Contact Cooling Water. As discussed in Section III, contact cooling water is used in extrusion operations to accomplish a heat treatment effect, either by spraying water onto the metal as it emerges from the die or press, or by direct quenching in a water bath. Contact cooling water in one of the operations is recycled and periodically batch dumped; the other operation discharges with no recycle. The average of the two reported production normalized discharge flows is the BPT discharge allowance, 83.2 l/kg (20.0 gal/ton).

Nickel-Cobalt Extrusion Press Hydraulic Fluid Leakage. Discharge of hydraulic fluid leakage was reported from one extrusion operation. The BPT discharge allowance of 232 l/kg (55.6 gal/ton) is based on the production normalized discharge flow from this operation.

Forging

Forging is performed at 31 plants in the nickel-cobalt forming subcategory. The following information is available from these plants:

Number of plants and operations using lubricants: 5 plants, 6 operations

Number of plants and operations using contact cooling water: 6

Number of plants and operations reporting hydraulic fluid leakage: 1

Number of equipment cleaning operations: 1 plant, 2 operations.

Approximately 20 dry forging operations were reported.

Nickel-Cobalt Forging Spent Lubricants. The lubricants from the six operations are either contract hauled directly or only lost through evaporation and drag-out. It is better to remove the neat oil and graphite-based lubricants typically used in forging operations from this subcategory and not to discharge the stream than to commingle the lubricants with other water streams and then remove them later. Therefore, this waste stream should not be discharged.

Nickel-Cobalt Forging Contact Cooling Water. Five of the six plants that reported this waste stream provided flow information. Four plants discharge the cooling water without any recycle while one plant recycles over 95 percent of the water. The BPT discharge of 474 l/kg (114 gal/ton) is based on the average production normalized water use for the five plants providing flow information.

Nickel-Cobalt Forging Equipment Cleaning Wastewater. One plant reported using water to clean the equipment in its two forging operations. The BPT discharge allowance, based on the average of the two production normalized water uses, is 40.0 l/kg (9.57 gal/ton).

Nickel-Cobalt Forging Press Hydraulic Fluid Leakage. One plant reported a discharge of forging press hydraulic fluid leakage. The BPT discharge allowance of 187 l/kg (44.8 gal/ton) is based on the production normalized discharge flow of hydraulic leakage from this operation.

Casting

The following information was reported on casting operations in this subcategory:

Total number of plants: 12

Number of plants and operations with stationary casting: 10 plants, 12 operations

Number using contact cooling water: 2

Number dry: 10

Number of plants and operations with vacuum melting and casting:

3

Number of plants with vacuum melting steam condensate: 2

Number dry: 1

Number of plants and operations with electroflux remelting: 2

Number dry: 2.

Nickel-Cobalt Stationary Casting Contact Cooling Water. Two stationary casting operations use contact cooling water. In one operation the cooling water is completely reused in other nonferrous forming operations at the plant. The cooling water is not recycled in the other operation but some is lost through evaporation and drag-out. The BPT allowance of 12,100 l/kg (2,900 gal/ton) is based on the average production normalized water use for the two operations.

Nickel-Cobalt Vacuum Melting Steam Condensate. Information was reported on two vacuum melting operations which generate a steam condensate waste stream. In one operation the entire volume of steam condensate is reused for surface treatment rinse. The other operation recycles 98 percent of the steam condensate through a cooling tower. Analysis of a sample of the bleed stream from the cooling tower indicated that there are no pollutants present above treatable concentrations. In fact, some pollutants were found at concentrations lower than source water concentrations. Vacuum melting steam condensate can, therefore, be reused in the generation of steam for vacuum melting or in other processes present at the forming plant. The feasibility of reusing the condensate is demonstrated by the operation which currently reuses the condensate for surface treatment rinse. Therefore, since analysis of the condensate indicates that no pollutants are present at treatable concentrations, and it is current industry practice to reuse the condensate in other forming operations, no allowance is provided for this stream.

Metal Powder Production

Metal powder production operations are performed at 15 plants. Atomization wastewater is generated in a total of seven operations at six plants. No wastewater is generated from atomization processes at nine plants.

Nickel-Cobalt Metal Powder Production Atomization Wastewater. Production normalized discharge flows for this waste stream vary widely from 1,280 l/kg to 75,300 l/kg. The BPT flow allowance of 2,620 l/kg (629 gal/ton) is based on the median of seven production normalized discharge flows. Because of the large range of production normalized discharge flows, the median is believed to be a better representation of the current typical water use for this operation than the average (arithmetic mean).

Solution Heat Treatment

Heat treatment operations are performed at 31 plants. Contact cooling water is used in a total of 22 operations at 17 plants. No water is used at 14 plants.

Nickel-Cobalt Annealing and Solution Heat Treatment Contact Cooling Water. No BPT discharge allowance is provided for this stream. The zero discharge allowance is based on 100 percent reuse of the wastewater, either as annealing contact cooling water or in other processes present at the forming plants. Analysis of a sample of this wastewater indicates that there are no pollutants present above treatable concentrations and therefore, reuse is possible. Furthermore, three operations which use annealing contact cooling water recycle all of the cooling water. In one operation the cooling water is treated by oil skimming and recycled to the cooling process. In two operations, the cooling water is recycled without treatment.

Surface Treatment

Thirty plants provided information on surface treatment operations in the nickel-cobalt forming subcategory.

Nickel-Cobalt Surface Treatment Spent Baths. A total of 39 surface treatment bath operations were identified. Spent baths from six operations are discharged to evaporation ponds, baths from 10 operations are contract hauled to treatment and disposal off-site and 23 baths are discharged to either a POTW or surface water. The BPT regulatory flow of 935 l/kg (224 gal/ton) is based on the average of the 24 reported production normalized flows. Information sufficient to calculate production normalized flows was provided for 25 baths that are discharged or contract hauled.

Nickel-Cobalt Surface Treatment Rinse. Thirty-three surface treatment rinse operations were identified. Rinse from seven operations is discharged to evaporation ponds or surface impoundments, and rinse from two operations is contract hauled. In one process, the rinse is treated and reused. The BPT flow of 23,600 l/kg (5,640 gal/ton) is based on the average of the 24 production normalized water uses reported for this operation.

Ammonia Rinse Treatment

Two plants reported using an ammonia rinse in a total of 3 operations.

Nickel-Cobalt Ammonia Rinse. All three operations are stagnant rinses with batch discharges. The BPT flow of 14.8 l/kg (3.54 gal/ton) is based on the average production normalized discharge flow from the three operations.

Alkaline Cleaning

Eighteen plants provided information on alkaline cleaning operations in the nickel-cobalt subcategory. The reported operations include 23 baths and 22 rinses.

Nickel-Cobalt Alkaline Cleaning Spent Baths. Seven baths are discharged to evaporation ponds or impoundments, and two are contract hauled to treatment and disposal off-site. Flow data were available for 15 baths. Production normalized discharge flows for these baths vary from 1.2 l/kg to 231 l/kg. The BPT flow of 33.9 l/kg (8.13 gal/ton) is based on the median production normalized discharge flow from the 15 baths. The median is believed to be a better representation of the current typical flow for this operation than the average (arithmetic mean) because of the large range of production normalized discharge flows. The production normalized water use for a combined bath and rinse was not included in the average because the individual discharges could not be discerned.

Nickel-Cobalt Alkaline Cleaning Rinse. Rinse from eight operations is discharged to evaporation ponds, impoundments, or applied to land. Rinse from one operation is treated and reused. Water use data are available for a total of 12 alkaline cleaning rinse operations. The BPT flow of 2,330 l/kg (559 gal/ton) is the average production normalized water use for 11 operations. The production normalized water use for a combined bath and rinse was not included in the average because the individual discharges could not be discerned.

Molten Salt Treatment

Six plants reported using molten salt treatment in a total of eight operations.

Nickel-Cobalt Molten Salt Rinse. The BPT flow for this stream is 8,440 l/kg (2,020 gal/ton). This flow is the average production normalized water use for six nonrecycled overflowing rinses. The water uses for two stagnant rinses were not included in the average because flow reduction through stagnant rinsing is considered to be part of the BAT technology.

Sawing or Grinding

Twenty-one plants reported using emulsion lubricants in a total of 25 sawing or grinding operations. One rinse operation was also reported.

Nickel-Cobalt Sawing or Grinding Spent Emulsions. Information sufficient to calculate production normalized discharge flows was reported for five operations. The BPT flow allowance of 39.4 l/kg (9.45 gal/ton) is based on the average production normalized discharge flow from the five operations.

Nickel-Cobalt Sawing or Grinding Rinse. One plant reported generating this waste stream. The BPT regulatory flow of 1,810 l/kg (435 gal/ton) is based on the production normalized discharge flow from this plant.

Steam Cleaning

Nickel-Cobalt Steam Cleaning Condensate. Two plants reported the discharge of contact steam condensate from product cleaning operations. Neither plant recycles the condensate. Only one plant reported information sufficient to calculate production normalized flows. The BPT discharge allowance is the one reported production normalized discharge flow, 30.1 l/kg (7.22 gal/ton).

Product Testing

Nickel-Cobalt Hydrostatic Tube Testing and Ultrasonic Testing Wastewater. The Agency believes that hydrostatic tube testing and ultrasonic testing wastewater can be recycled or reused in other processes present at the forming plant. Also, some plants in this category discharge wastewater from these operations less than once per year, which is effectively zero discharge. Therefore, no allowance for the discharge of process wastewater pollutants is provided for this stream.

Nickel-Cobalt Dye Penetrant Testing Wastewater. Three plants reported generating wastewater from six dye penetrant testing operations. Flow information was reported for two operations. The BPT discharge allowance of 213 l/kg (50.9 gal/ton) is the average production normalized discharge flow from the two operations.

Miscellaneous Wastewater

Nickel-Cobalt Miscellaneous Wastewater Sources. Some low volume sources of wastewater were reported in dcps and observed during the site and sampling visits. These include wastewater from maintenance and cleanup. The Agency has determined that none of the plants reporting these specific water uses discharge these wastewaters to surface waters (directly or indirectly). However, because the Agency believes this type of low volume periodic discharge occurs at most plants, the Agency has combined these individual wastewater sources under the term "miscellaneous wastewater sources" and provided a BPT discharge allowance of 246 l/kg (58.4 gal/ton).

Degreasing

Nickel-Cobalt Degreasing Spent Solvents. Only a small number of surveyed plants with solvent degreasing operations indicated having process wastewater streams associated with the operation. Because most plants practice solvent degreasing without wastewater discharge, the Agency believes zero discharge of wastewater is an appropriate discharge limitation.

Wet Air Pollution Control

Nickel-Cobalt Wet Air Pollution Control Blowdown. Wet air pollution control devices are used to control air emissions from surface treatment operations, shot blasting, molten salt treatment and rolling. Six plants reported achieving over 90 percent recycle of the scrubber water. Therefore, the BPT discharge allowance of 810 l/kg (194 gal/ton) is based on 90 percent recycle of the average production normalized water use for six operations since 90 percent recycle or greater is current typical industry practice.

Electrocoating

Nickel-Cobalt Electrocoating Rinse. One plant reported discharging electrocoating rinse. The BPT regulatory flow of 3,370 l/kg (807 gal/ton) is based on the production normalized discharge flow from this one plant.

Regulated Pollutants

The priority pollutants considered for regulation under BPT are listed in Section VI along with an explanation of why they were considered. The priority pollutants considered for regulation in this subcategory are cadmium, chromium, copper, lead, nickel, and zinc. Chromium and nickel are selected for regulation under BPT along with fluoride, total suspended solids, oil and grease, and pH. The priority pollutants cadmium, copper, lead, and zinc are not specifically regulated under BPT for the reasons given in Section X. The basis for regulating total suspended solids, oil and grease, and pH under BPT was discussed earlier in this section. The basis for regulating total chromium, nickel, and fluoride is discussed below.

Total chromium is regulated since it includes both hexavalent and trivalent forms of chromium. Only the trivalent form is removed by the lime and settle technology. Therefore, the hexavalent form must be reduced by preliminary chromium reduction treatment in order to meet the limitations on chromium in this subcategory. Chromium was found at treatable concentrations in 71 of 90 raw wastewater samples, and 16 of the 18 raw wastewater streams in which it was analyzed.

Nickel has been selected for regulation under BPT since it was found at treatable concentrations in 81 of 90 raw wastewater samples and because it is the metal being processed. Nickel was present at treatable concentrations in 16 of the 18 raw wastewater streams in which it was analyzed. The Agency believes that when chromium and nickel are controlled with the application of lime and settle technology and preliminary treatment when needed, the control of other priority pollutants which may be present is assured.

Fluoride was found at treatable concentrations in 21 of 89 raw wastewater samples and in six of 18 raw wastewater streams in which it was analyzed. Therefore, fluoride is selected for regulation under BPT.

Treatment Train

The BPT model treatment train for the nickel-cobalt forming subcategory consists of preliminary treatment when necessary, specifically emulsion breaking and oil skimming, and chromium reduction. The effluent from preliminary treatment is combined with other wastewater for common treatment by oil skimming and lime and settle. Waste streams potentially needing preliminary treatment are listed in Table IX-3. Figure IX-1 presents a schematic of the general BPT treatment train for the nonferrous metals forming category.

Effluent Limitations

The pollutant mass discharge limitations (milligrams of pollutant per off-kilogram of PNP) were calculated by multiplying the BPT regulatory flows summarized in Table IX-15 (l/kg) by the concentration achievable by the BPT model treatment system summarized in Table VII-21 (mg/l) for each pollutant parameter considered for regulation at BPT ($1/\text{off-kg} \times \text{mg/l} \times 1 \text{ kg}/1,000 \text{ kg} = \text{mg/off-kg}$). The results of this computation for all waste streams and regulated pollutants in the nickel-cobalt forming subcategory are summarized in Table IX-16. This limitation table lists all the pollutants which were considered for regulation; those specifically regulated are marked with an asterisk.

Costs and Benefits

In establishing BPT, EPA must consider the cost of treatment and control in relation to the effluent reduction benefits. BPT costs and benefits are tabulated along with BAT costs and benefits in Section X. As shown in Table X-5 (page xxxx), the application of BPT to the total nickel-cobalt forming subcategory will remove approximately 729,230 kg/yr (1,604,300 lbs/yr) of pollutants including 99,570 kg/yr (219,050 lbs/yr) of toxic metals. As shown in Table X-1 (page xxxx), the corresponding capital and annual costs (1982 dollars) for this removal are \$3.342 million and \$2.077 million per year, respectively. As shown in Table X-15 (page xxxx), the application of BPT to direct dischargers only will remove approximately 21,590 kg/yr (47,500 lbs/yr) of pollutants including 10,400 kg/yr (22,880 lbs/yr) of toxic metals. As shown in Table X-2 (page xxxx), the corresponding capital and annual costs (1982 dollars) for this removal are \$392,000 and \$186,000 per year, respectively. The Agency concludes that these pollutant removals justify the costs incurred by plants in this subcategory.

PRECIOUS METALS FORMING SUBCATEGORY

Production Operations and Discharge Flows

Production operations that generate process wastewater in the precious metals forming subcategory include rolling, drawing, metal powder production, direct chill casting, shot casting, stationary casting, semi-continuous and continuous casting, heat treatment, surface treatment, alkaline cleaning, tumbling, burnishing, sawing, grinding, pressure bonding, and degreasing. The wet scrubbers used for air pollution control at some plants are also a source of process wastewater. Water use practices, wastewater streams and wastewater discharge flows from these operations were discussed in Section V. This information provided the basis for development of the BPT regulatory flow allowances summarized in Table IX-17. The following paragraphs discuss the basis for the BPT flow allowances for each waste stream.

Rolling

Rolling is performed at 33 plants in this subcategory. The following information is available from these plants:

Number of plants and operations using neat oil lubricant: 2
Number of plants and operations using emulsion lubricant: 5
plants, 6 operations.
No lubricants were reported to be used at approximately 25 plants.

Precious Metals Rolling Spent Neat Oils. No discharge is the BPT requirement for this waste stream. Spent neat oil is not discharged from the two rolling operations where the use of neat oil lubricants was reported. One operation achieves zero discharge through recirculation with some loss due to drag-out on the product. No information regarding how zero discharge is achieved was reported for the other operation. Since neat oils are pure oil streams, with no water fraction, it is better to remove the oil directly by contract hauling and not to discharge the stream than to commingle the oil with water streams and then remove it later.

Precious Metals Rolling Spent Emulsions. Information sufficient to calculate production normalized flows was available for three of the six operations where the use of emulsion lubricants was reported. The BPT regulatory allowance of 77.1 l/kg (18.5 gal/ton) is based on the average of the three production normalized discharge flows. This regulatory flow incorporates recycle with periodic discharge of spent emulsion since this is current practice at the three plants supplying flow data for this wastewater stream.

Drawing

Drawing is performed at 25 precious metals forming plants. The following information is available from these plants:

Number of plants and operations using neat oil lubricant: 1
Number of plants and operations using emulsion lubricant: 8 plants, 12 operations
Number of plants and operations using soap solutions: 2.
No lubricants are used at approximately 15 plants.

Precious Metals Drawing Spent Neat Oils. Neat oils are completely consumed in the one drawing process where neat oil lubricants are used. As discussed previously, should a plant need to dispose of these lubricants it is better to remove them directly by contract hauling and not to discharge the stream. Therefore, this stream should not be discharged.

Precious Metals Drawing Spent Emulsions. Drawing emulsions are completely recycled with the only loss due to evaporation and drag-out in three operations. Seven operations recycle the emulsion with periodic batch discharges. The spent emulsion from four of the seven operations is contract hauled to treatment and disposal off-site. The BPT regulatory flow of 47.5 l/kg (11.4 gal/ton) is based on the average of five non-zero production normalized discharge flows from operations where emulsion is recycled with periodic batch discharges. The production normalized discharge flow from one operation where no recycle is practiced was not included in the BPT regulatory flow calculation since once-through discharge of spent emulsion is not indicative of current industry practice.

Precious Metals Drawing Spent Soap Solutions. No discharge data were provided on one operation and one operation was reported to periodically discharge spent soap solution. The BPT discharge allowance is the one reported value, 3.12 l/kg (0.748 gal/ton).

Metal Powder Production

Metal powder production operations are performed at eight plants. Atomization wastewater is generated at one of these plants.

Precious Metals Metal Powder Production Atomization Wastewater. The BPT discharge allowance, based on the one reported production normalized discharge flow, is 6,680 l/kg (1,600 gal/ton).

Casting

Casting is performed at 23 plants in the precious metals forming subcategory. The following information is available from these plants:

Number of plants and operations with direct chill casting using contact cooling water: 3 plants, 4 operations
Number of plants and operations with shot casting using contact cooling water: 1
Number of plants and operations with stationary casting using contact cooling water: 5
Number of plants and operations with semi-continuous and continuous casting using contact cooling water: 5.

Precious Metals Direct Chill Casting Contact Cooling Water. In one reported direct chill casting operation the cooling water is completely recycled with no discharge. The contact cooling water is discharged from two operations on a once-through basis. The BPT flow allowance of 10,800 l/kg (2,590 gal/ton) is based on the average production normalized water use from these two operations. The production normalized water use from one operation with an unreported discharge flow was not used in the BPT flow calculation since it is nearly 10 times greater than the water use for the other two discharging operations, and therefore not indicative of current industry practice.

Precious Metals Shot Casting Contact Cooling Water. The BPT regulatory flow allowance is the production normalized water use from the one reported operation, 3,670 l/kg (880 gal/ton).

Precious Metals Stationary Casting Contact Cooling Water. Five plants reported using contact cooling water to cool stationary castings. One plant completely recycles this water, one practices 99.8 percent recycle, and one plant only discharges the cooling water periodically. Water recycle practices were not reported by the other two plants. No BPT discharge allowance is provided for this waste stream. The zero discharge allowance is based on practices currently in use at one plant in this subcategory and in plants from several other subcategories in the category which perform the same operation on other metals.

Precious Metals Semi-Continuous and Continuous Casting Contact Cooling Water. Two plants completely recycle the cooling water with no discharge. Flow data were reported for one of the three plants which discharge this stream. The BPT regulatory allowance is based on the one reported, nonrecycled production normalized water use, 10,300 l/kg (2,480 gal/ton).

Heat Treatment

Precious Metals Heat Treatment Contact Cooling Water. Eleven plants reported using contact cooling water in a total of 20 heat treatment operations. Contact cooling water is used in annealing, rolling, and extrusion heat treatment. The BPT regulatory flow is based on the median of 12 reported production normalized water uses, 4,170 l/kg (1,000 gal/ton). The median is believed to be a better representation of the current typical water use for this operation than the average (arithmetic mean) because of the large range of reported production normalized water uses (659 l/kg to 147,000 l/kg).

Surface Treatment

Seventeen plants supplied information on surface treatment operations. Wastewater is generated and discharged from these operations as follows:

Number of baths contract hauled or discharged: 16

Number of baths never discharged: 4

Number of rinses discharged: 18 Number of rinses treated and completely recycled: 1.

Precious Metals Surface Treatment Spent Baths. No wastewater discharge data were reported for 12 of the operations. The BPT discharge allowance is the average of the four reported production normalized discharge flows, 96.3 l/kkg (23.1 gal/ton).

Precious Metals Surface Treatment Rinse. One rinse operation uses two-stage countercurrent cascade rinsing and another operation uses three-stage countercurrent cascade rinsing. The BPT regulatory flow of 6,160 l/kkg (1,480 gal/ton) is based on the average production normalized water use for seven noncascaded rinse operations because flow reduction through cascade rinsing is considered to be part of the BAT technology.

Alkaline Cleaning

Nine plants supplied information on alkaline cleaning operations. Seven plants supplied information on alkaline cleaning prebonding operations. Wastewater is generated and discharged from these operations as follows:

Number of alkaline cleaning baths contract hauled or discharged: 8

Number of alkaline cleaning baths never discharged: 0

Number of alkaline cleaning rinses discharged: 7

Number of alkaline cleaning prebonding operations discharging wastewater: 8.

Precious Metals Alkaline Cleaning Spent Baths. Production normalized flow information is available for one bath. The BPT regulatory flow of 60.0 l/kkg (14.4 gal/ton) is based on the production normalized discharge flow from this bath.

Precious Metals Alkaline Cleaning Rinse. Flow data were available for four alkaline cleaning rinse operations. No recycle or other flow reduction techniques are used for any of these operations. The BPT regulatory flow of 11,200 l/kkg (2,690 gal/ton) is based on the average production normalized water use from the four operations.

Precious Metals Alkaline Cleaning Prebonding Wastewater. Flow information is available for all of the alkaline cleaning prebonding operations. The BPT regulatory flow of 11,600 l/kg (2,770 gal/ton) is based on the median production normalized water use for the eight operations. The median is believed to be a better representation of the current typical water use for this operation than the average (arithmetic mean) because of the large range of reported production normalized water uses (10.2 l/kg to 93,800 l/kg).

Tumbling or Burnishing

Precious Metals Tumbling or Burnishing Wastewater. Flow information was reported for two tumbling operations and two burnishing operations. No recycle is practiced for any of these operations. The BPT flow allowance of 12,100 l/kg (2,910 gal/ton) is based on the average production normalized water use for the four operations.

Sawing or Grinding

Precious Metals Sawing or Grinding Spent Neat Oils. Neat oil is used as a lubricant in one grinding operation. The neat oil is completely recycled with some loss due to evaporation and drag-out. As previously discussed, since neat oils are pure oil streams, with no water fraction, it is better to remove the oil directly by contract hauling and not to discharge the stream than to commingle the oil with water streams and then remove it later. Therefore, the BPT flow allowance is zero.

Precious Metals Sawing or Grinding Spent Emulsions. An emulsion lubricant is used in four operations. In each of the four operations, the emulsion is recirculated with periodic discharges contract hauled to treatment and disposal off-site. However, a BPT regulatory flow has been established for this stream since the spent emulsion could be treated on-site and the water fraction discharged (with the oil fraction contract hauled). The BPT regulatory flow of 93.4 l/kg (22.4 gal/ton) is based on the median production normalized discharge flow from the four operations. The median is believed to be a better representation of the current typical water use for this operation than the average (arithmetic mean) because of the large range of reported production normalized discharge flows (3.17 l/kg to 2,775 l/kg).

Pressure Bonding

Precious Metals Pressure Bonding Contact Cooling Water. One plant reported using contact cooling water after a pressure bonding operation. The production normalized discharge flow from this operation is the BPT regulatory flow, 83.5 l/kg (20.0 gal/ton).

Degreasing

Precious Metals Degreasing Spent Solvents. Only a small number of surveyed plants with solvent degreasing operations have process wastewater streams associated with the operation. Because most plants practice solvent degreasing without wastewater discharge, the Agency believes zero discharge of wastewater is an appropriate discharge limitation.

Wet Air Pollution Control

Precious Metals Wet Air Pollution Control Blowdown. Wet air pollution control devices are used to control air emissions from two surface treatment operations and three casting operations. The scrubber water is completely recycled with no discharge in two operations, and a periodic discharge is contract hauled to treatment and disposal off-site in a third operation. Since zero discharge from wet air pollution devices is common practice in this subcategory, no BPT flow allowance is provided for this stream.

Deleted Waste Streams

Precious Metals Metal Powder Production Milling Wastewater. At proposal, an allowance was written for metal powder production milling wastewater. Upon re-examination of the information available, it was determined that the operation upon which the allowance was based is powder metallurgy part milling, not powder milling. The discharge from this operation is covered by tumbling, burnishing wastewater allowance and its reported PNF has been included in the calculation of the tumbling, burnishing wastewater regulatory flow and discharge allowance.

Regulated Pollutants

The priority pollutants considered for regulation under BPT are listed in Section VI along with an explanation of why they have been considered. The pollutants selected for regulation under BPT are cadmium, copper, lead, silver, cyanide, oil and grease, total suspended solids and pH. The priority metal pollutants chromium, nickel, and zinc, listed in Section VI are not specifically regulated under BPT for the reasons explained in Section X. The basis for regulating oil and grease, total suspended solids and pH was discussed earlier in this section. The basis for regulating cadmium, copper, lead, silver, and cyanide is discussed below.

Cadmium is selected for regulation since it was found at treatable concentrations in 23 of 37 raw wastewater samples. Cadmium was present at treatable concentrations in rolling spent emulsions, shot casting contact cooling water, semi-continuous and continuous casting contact cooling water, heat treatment contact cooling water, surface treatment spent baths, surface treatment rinse, alkaline cleaning spent baths, alkaline cleaning

prebonding wastewater, tumbling and burnishing wastewater, and pressure bonding contact cooling water.

Copper is selected for regulation since it was found at treatable concentrations in 32 of 37 raw wastewater samples. Copper was found at treatable concentrations in all raw wastewater streams in which it was analyzed. This includes all of the waste streams where cadmium was found at treatable concentrations, and also drawing spent emulsions.

Lead is selected for regulation since it was found at treatable concentrations in 25 of 37 raw wastewater samples. Lead was found at treatable concentration in 11 of the 12 raw wastewater streams in which it was analyzed.

Silver is selected for regulation because it was found at treatable concentrations in 11 of 37 raw wastewater samples, it is a toxic metal, and it is one of the metals formed in this subcategory. Silver was found at treatable concentrations in rolling spent emulsions, drawing spent emulsions, surface treatment spent baths, surface treatment rinse, alkaline cleaning spent baths, and tumbling, burnishing wastewater.

Cyanide is selected for regulation since it was found at treatable concentrations in alkaline cleaning prebonding wastewater and semi-continuous and continuous casting contact cooling water. Preliminary cyanide precipitation is needed to remove this pollutant from wastewater. Therefore regulation of cyanide is appropriate for this subcategory.

Treatment Train

The BPT model treatment train for the precious metals forming subcategory consists of preliminary treatment when necessary, specifically chemical emulsion breaking and oil skimming, and cyanide precipitation. The effluent from preliminary treatment is combined with other wastewater for common treatment by oil skimming and lime and settle. Waste streams potentially needing preliminary treatment are listed in Table IX-4. Figure IX-1 presents a schematic of the general BPT treatment train for the nonferrous metals forming category.

Effluent Limitations

The pollutant mass discharge limitations (milligrams of pollutant per metric ton of PNP) were calculated by multiplying the BPT regulatory flows summarized in Table IX-17 (l/kg) by the concentration achievable by the BPT model treatment system summarized in Table VII-21 (mg/l) for each pollutant parameter considered for regulation at BPT ($1/\text{off-kg} \times \text{mg/l} \times 1 \text{ kkg}/1,000 \text{ kg} = \text{mg/off-kg}$). The results of this computation for all waste streams and regulated pollutants in the precious metals forming subcategory are summarized in Table IX-18. This limitation table lists all the pollutants which were considered for regulation and those specifically regulated are marked with an asterisk.

Costs and Benefits

In establishing BPT, EPA must consider the cost of treatment and control in relation to the effluent reduction benefits. BPT costs and benefits are tabulated along with BAT costs and benefits in Section X. As shown in Table X-6 (page xxxx), the application of BPT to the total precious metals forming subcategory will remove approximately 12,635 kg/yr (27,800 lbs/yr) of pollutants including 110 kg/yr (242 lbs/yr) of toxic metals. As shown in Table X-1 (page xxxx), the corresponding capital and annual costs (1982 dollars) for this removal are \$1.013 million and \$0.414 million per year, respectively. As shown in Table X-16 (page xxxx), the application of BPT to direct dischargers only will remove approximately 2,875 kg/yr (6,325 lbs/yr) of pollutants including 21 kg/yr (46 lbs/yr) of toxic metals. As shown in Table X-2 (page xxxx), the corresponding capital and annual costs (1982 dollars) for this removal are \$226,000 and \$98,000 per year, respectively. The Agency concludes that these pollutant removals justify the costs incurred by plants in this subcategory.

REFRACTORY METALS FORMING SUBCATEGORY

Production Operations and Discharge Flows

Production operations that generate process wastewater in the refractory metals forming subcategory include rolling, drawing, extrusion, forging, metal powder production, surface treatment, alkaline cleaning, molten salt treatment, tumbling, burnishing, sawing, grinding, product testing, equipment cleaning, degreasing and a few miscellaneous operations. The wet scrubbers used for air pollution control at some plants are also a source of process wastewater. Water use practices, wastewater streams and wastewater discharge flows from these operations were discussed in Section V. This information provided the basis for development of the BPT regulatory flow allowances summarized in Table IX-19. The following paragraphs discuss the basis for the BPT flow allowances for each waste stream.

Rolling

Rolling is performed at approximately 16 plants in the refractory metals forming subcategory. The following information is available from these plants:

Number of plants and operations using neat oil or graphite-based lubricants: 2

Number of plants and operations using emulsion lubricants: 1.

No lubricants are used at approximately 13 plants.

Refractory Metals Rolling Spent Neat Oils and Graphite Based Lubricants. One operation uses a neat oil lubricant and the other operation uses a graphite-based lubricant. The lubricant in both processes is completely recycled with some loss due to

evaporation and drag-out. Should a plant find the need to dispose these lubricants, it would be better to remove the lubricants directly by contract hauling and not to discharge the stream rather than to combine the lubricants with water streams, and remove them later. Therefore, rolling spent neat oils and graphite-based lubricants should not be discharged.

Refractory Metals Rolling Spent Emulsions. Spent emulsion in the one rolling operation which uses an emulsified lubricant is periodically batch dumped and contract hauled. As discussed previously for rolling spent emulsions in the lead-tin-bismuth forming subcategory, the spent emulsions are often treated on-site and the water discharged (with the oil fraction contract hauled) by plants in this category and other categories. Therefore, the production normalized discharge flow from the one operation is the BPT discharge allowance, 429 l/kg (103 gal/ton).

Drawing

Drawing is performed at approximately 16 refractory metals forming plants. Six plants reported using lubricants in a total of seven drawing operations.

Refractory Metals Drawing Spent Lubricants. No lubricant is discharged from six of the seven drawing operations reporting the use of lubricants. In four operations, the lubricant is completely recycled with some lubricant consumed or lost through evaporation and drag-out. In the other zero discharge operations, the only losses are due to lubricant being consumed and burned off or through evaporation and drag-out. One operation has no available water discharge data. The drawing lubricants used include neat oils, graphite-based lubricants, and dry soap lubricants. Should a plant find the need to dispose of these lubricants, it would be better to remove them directly by contract hauling and not to discharge the stream rather than to combine the lubricants with water streams and remove them later. Therefore, drawing spent lubricants should not be discharged.

Extrusion

Extrusion is performed at approximately seven plants in this subcategory. The following information is available from these plants:

Number of plants and operations using lubricants: 3

Number of plants and operations reporting hydraulic fluid leakage: 1.

Four plants did not report the use of lubricants or hydraulic fluid leakage from their extrusion operations.

Refractory Metals Extrusion Spent Lubricants. There are no reported discharges of spent extrusion lubricants. Should a plant need to dispose of these lubricants, it would be better to remove them directly by contract hauling rather than to combine

the lubricants with wastewater streams and remove them later. Therefore, this waste stream should not be discharged.

Refractory Metals Extrusion Press Hydraulic Fluid Leakage. Leakage of extrusion press hydraulic fluid was observed at one sampled plant. The BPT discharge allowance is based on the production normalized discharge flow for this operation, 1,190 l/kg (235 gal/ton).

Forging

Forging is performed at approximately 10 refractory metals forming plants. The following information is available for these plants:

Number of plants and operations using lubricants: 3 plants, 4 operations

Number of plants and operations using contact cooling water: 2.
No lubricants or contact cooling water was reported to be used at over five plants.

Refractory Metals Forging Spent Lubricants. No lubricants are discharged from the four operations for which lubricant was reported. The only loss is due to evaporation and drag-out. Should a plant find the need to dispose of these lubricants, it would be better to remove the lubricants directly by contract hauling and not to discharge the stream than to combine the lubricants with wastewater streams and remove them later. Therefore, this waste stream should not be discharged.

Refractory Metals Forging Contact Cooling Water. Flow data were provided for one operation. None of the contact cooling water in this operation is recycled. The BPT discharge allowance is the production normalized water use from this one operation, 323 l/kg (77.5 gal/ton).

Metal Powder Production

Metal powder production operations are performed at approximately 46 refractory metal forming plants. The following information is available from these plants:

Number of plants and operations generating metal powder production wastewater: 3 plants, 5 operations

Number of plants and operations generating floorwash wastewater: 2.

No process wastewater is generated from metal powder production operations at approximately 40 plants.

Refractory Metals Metal Powder Production Wastewater. None of the operations practice any recycle of the metal powder production wastewater. No wastewater is discharged from two operations since it evaporates in drying operations. The BPT regulatory flow of 281 l/kg (67.3 gal/ton) is based on the median production normalized water use for five operations which discharge.

The median is believed to be a better representation of the current typical water use for this operation than the average (arithmetic mean) because of the large range of reported production normalized water uses (37.1 l/kg to 34,500 l/kg).

Refractory Metals Metal Powder Production Floorwash Wastewater. The floorwash wastewater is completely recycled by one plant while at the other plant the wastewater is contract hauled. Since neither plant which generates the waste stream reported discharging it, there shall be no discharge from this waste stream.

Refractory Metals Metal Powder Pressing Spent Lubricants. The one plant which reported using metal powder pressing lubricants achieves zero discharge of the lubricants through 100 percent recycle. Therefore, the BPT flow allowance is zero.

Surface Treatment

Twelve plants supplied information on refractory metals surface treatment operations.

Refractory Metals Surface Treatment Spent Baths. Flow data were supplied for six of the 15 reported surface treatment baths. The BPT regulatory flow of 389 l/kg (93.3 gal/ton) is based on the average production normalized discharge flow from the six operations.

Refractory Metals Surface Treatment Rinse. Fourteen surface treatment rinse operations were reported. Two-stage countercurrent cascade rinsing is practiced at two of the operations. No flow reduction techniques were reported for the other 12 operations. Discharge data were available for the two countercurrent cascade rinses and four non-cascaded rinse operations. The BPT flow of 121,000 l/kg (29,100 gal/ton) is based on the average production normalized water use from the four non-cascaded rinse operations. The countercurrent cascade rinse operations were not included in the flow calculation since countercurrent cascade rinsing is a BAT technology, and does not represent current typical water use for this operation.

Alkaline Cleaning

Fourteen plants supplied information on alkaline cleaning operations. A total of 14 alkaline cleaning baths and 18 alkaline cleaning rinses were reported.

Refractory Metals Alkaline Cleaning Spent Baths. Flow data were available for three of the 14 reported alkaline cleaning baths. The BPT regulatory flow of 334 l/kg (80.2 gal/ton) is based on the average production normalized discharge flow from the three operations.

Refractory Metals Alkaline Cleaning Rinse. Flow data were available for 11 rinse operations. No flow reduction practices

(countercurrent cascade rinsing, recycle, etc.) were reported for any of these operations. The BPT regulatory flow of 816,000 l/kg (196,000 gal/ton) is based on the average production normalized water use from the 11 operations.

Molten Salt Treatment

Refractory Metals Molten Salt Rinse. Five plants reported a total of six molten salt rinse operations. No flow reduction practices were reported for five of the operations. In one operation, a decreased flow rate is used to significantly reduce the discharge of molten salt rinse. Flow data were available for five of the six operations. The BPT regulatory flow of 6,330 l/kg (1,520 gal/ton) is based on the average production normalized water use from the five operations.

Tumbling or Burnishing Wastewater

Refractory Metals Tumbling or Burnishing Wastewater. Seven plants reported generating wastewater from 10 tumbling and burnishing operations. No flow reduction practices were reported for any of these operations. Flow data were supplied for eight of the operations. The BPT regulatory flow of 12,500 l/kg (3,000 gal/ton) is based on the median production normalized water use from the eight operations. The median is believed to be a better representation of the current typical water use for this operation than the average because of the large range of production normalized water uses (953 l/kg to 666,000 l/kg).

Sawing or Grinding

Thirteen plants reported generating wastewater from sawing or grinding operations. The following information is available from these plants:

Number of plants and operations using neat oil lubricant: 3
Number of plants and operations using emulsion lubricant: 8
plants, 16 operations
Number of plants and operations using contact cooling water: 5
plants, 8 operations
Number of plants and operations using a rinse: 2.

Refractory Metals Sawing or Grinding Spent Neat Oils. No discharge information was reported for one operation. Spent neat oils are contract hauled to treatment and disposal off-site in the other two operations. Since neat oils are pure oil streams, with no water fraction, it is better to remove the oil directly by contract hauling and not to discharge the stream than to commingle the oil with water streams and remove it later. Therefore, this waste stream should not be discharged.

Refractory Metals Sawing or Grinding Spent Emulsions. The spent emulsions from six operations are contract hauled; emulsions are completely recycled in one operation; the only loss of emulsions from three operations is through drag-out or consumption.

Discharge data were available for four operations. The average production normalized discharge flow from the four operations is the BPT discharge allowance, 297 l/kg (71.1 gal/ton).

Refractory Metals Sawing or Grinding Contact Cooling Water. Zero discharge is achieved in three operations through 100 percent recycle; in one operation 80 percent of the cooling water is recycled; in another operation cooling water is only periodically discharged; no recycle is practiced in three operations. The BPT regulatory flow of 24,300 l/kg (5,820 gal/ton) is based on the average production normalized water use from the four operations where water use data were available.

Refractory Metals Sawing or Grinding Rinse. No recycle or other flow reduction practices are used in either of the two reported rinse operations. Flow data were provided for one operation. The BPT flow of 135 l/kg (32.5 gal/ton) is based on the production normalized water use for this operation.

Product Testing

Refractory Metals Dye Penetrant Testing Wastewater. Wastewater from a dye penetrant testing operation was observed at one sampled plant. The BPT discharge allowance is the production normalized discharge flow for this operation, 77.6 l/kg (18.6 gal/ton).

Equipment Cleaning

Refractory Metals Equipment Cleaning Wastewater. Three plants reported generating wastewater from cleaning various equipment such as spray driers, forging presses, ring rollers, tools, and wet abrasive saw areas. A total of six equipment cleaning operations were reported. In one operation, zero discharge is achieved by completely recycling the cleaning wastewater. The BPT regulatory flow of 1,360 l/kg (326 gal/ton) is based on the median production normalized discharge flow from the six operations. The six production normalized discharge flows included in the median calculation include five non-zero discharge flows and the zero discharge flow from the operation practicing 100 percent recycle. The median is believed to be a better representation of the current typical water use for this operation than the average because of the large range of production normalized discharge flows (0 l/kg to 21,140 l/kg).

Miscellaneous Wastewater

Refractory Metals Miscellaneous Wastewater. Miscellaneous wastewater streams identified in this subcategory include wastewater from a post oil coating dip rinse, a quench of extrusion tools, and spent emulsions from grinding the stainless steel rolls used in refractory metals rolling operations. The BPT discharge allowance is 345 l/kg (83.0 gal/ton), 10 percent of the one reported production normalized discharge flow. This

discharge is a free flowing tool quench which can be 90 percent flow reduced by recycling it through a holding tank.

Degreasing

Refractory Metals Degreasing Spent Solvents. Only a small number of surveyed plants with solvent degreasing operations have process wastewater streams associated with the operation. Because most plants practice solvent degreasing without wastewater discharge, the Agency believes zero discharge of wastewater is an appropriate discharge limitation.

Wet Air Pollution Control

Refractory Metals Wet Air Pollution Control Scrubber Blowdown. In this subcategory, wet air pollution control devices are used to control air emissions from metal powder production, surface treatment, surface coating, and sawing and grinding operations. The use of wet air pollution control devices was reported for a total of nine operations. Scrubber water from one operation is completely recycled with no discharge. In two other operations, the discharge flow of scrubber water is reduced by recycling over 90 percent of the scrubber water. Water use data were available for four operations. The BPT regulatory flow of 787 l/kg (189 gal/ton) is based on 90 percent reduction of the average production normalized water use from three of these operations. The production normalized water use for one operation was over 175 times larger than the other values and was believed to be so atypical of current typical water use that it was not included in the regulatory flow calculation.

Deleted Waste Streams

Following proposal, the Agency received additional data and conducted a review of all available data concerning wastewater discharges. This review led to a reinterpretation of some data reported prior to proposal. As a result, the following waste streams included in the proposed regulation have been deleted from the final regulation:

- o Extrusion Heat Treatment Contact Cooling Water,
- o Metal Powder Pressing Spent Lubricant,
- o Casting Contact Cooling Water, and
- o Post-Casting Wash Water.

Data included under these waste streams at proposal have been reclassified under other waste streams in this subcategory as appropriate.

Regulated Pollutants

The priority pollutants considered for regulation under BPT are listed in Section VI along with an explanation of why they were considered. The pollutants selected for regulation under BPT are copper, nickel, fluoride, molybdenum, oil and grease, total

suspended solids and pH. The priority pollutants chromium, lead, silver, and zinc, and the nonconventional pollutants columbium, tantalum, tungsten, and vanadium are not specifically regulated under BPT for the reasons explained in Section X. The basis for regulating oil and grease, total suspended solids, and pH under BPT was discussed earlier in this section. The basis for regulating copper, nickel, fluoride, and molybdenum is discussed below.

Copper is selected for regulation since it was found at treatable concentrations in nine of 25 raw wastewater samples. Copper was present at treatable concentrations in extrusion press hydraulic fluid leakage, surface treatment spent baths, surface treatment rinse, alkaline cleaning spent baths, tumbling and burnishing wastewater, and sawing or grinding contact cooling water.

Nickel is selected for regulation since it was found at treatable concentrations in 13 of 25 raw wastewater samples. Nickel was found at treatable concentrations in all wastewater streams listed in the previous paragraph for copper. It was also present at treatable concentrations in molten salt rinse and dye penetrant testing wastewater.

Fluoride is selected for regulation since it was found at treatable concentrations in seven of 21 raw wastewater samples. Fluoride was present at treatable concentrations in surface treatment rinse, alkaline cleaning spent baths, molten salt rinse, and wet air pollution control blowdown.

Molybdenum is selected for regulation since it was present at treatable concentrations in five of 25 raw wastewater samples and it is one of the metals formed in this subcategory. Molybdenum is specifically regulated under BPT because it will not be adequately removed by the technology (lime and settle) required for the removal of the regulated priority metal pollutants, copper and nickel. The addition of iron to a lime and settle system (i.e., iron coprecipitation) is necessary for effective removal of molybdenum. Regulation of priority metals only is not sufficient to ensure the removal of molybdenum from refractory metals forming wastewater.

Treatment Train

The BPT model treatment train for the refractory metals forming subcategory consists of preliminary treatment when necessary, specifically chemical emulsion breaking and oil skimming. The effluent from preliminary treatment is combined with other wastewater for common oil skimming, iron coprecipitation, and lime and settle treatment. Waste streams potentially needing preliminary treatment are listed in Table IX-5. Figure IX-1 presents a schematic of the general BPT treatment train for the nonferrous metals forming category.

Effluent Limitations

The pollutant mass discharge limitations (milligrams of pollutant per off-kilogram of PNP) were calculated by multiplying the BPT regulatory flows summarized in Table IX-19 (1/kkg) by the concentration achievable by the BPT model treatment system summarized in Table VII-21 (mg/l) for each pollutant parameter considered for regulation at BPT (1/kkg x mg/l x kkg/1,000 kg = mg/off-kg). The results of this computation for all waste streams and regulated pollutants in the refractory metals forming subcategory are summarized in Table IX-20. Although no limitations have been established for columbium, tantalum, tungsten, and vanadium, Table IX-20 includes mass discharge limitations for these pollutants which are attainable using the BPT model technology. These limitations are presented for the guidance of permit writers. Only daily maximum limitations are presented for columbium, tantalum, and vanadium, based on the detection limits of 0.12, 0.46, and 0.10 mg/l, respectively. Lime and settle treatment was determined to remove these pollutants to below their level of analytical quantification. The attainable monthly average discharge is expected to be lower than the one-day maximum limitation, but since it would be impossible to monitor for compliance with a lower level, no monthly average has been presented.

The limitations table lists all the pollutants which were considered for regulation. Those specifically regulated are marked with an asterisk.

Costs and Benefits

In establishing BPT, EPA must consider the cost of treatment and control in relation to the effluent reduction benefits. BPT costs and benefits are tabulated along with BAT costs and benefits in Section X. As shown in Table X-7 (page xxxx), the application of BPT to the total refractory metals forming subcategory will remove approximately 183,300 kg/yr (403,260 lbs/yr) of pollutants including 54 kg/yr (119 lbs/yr) of toxic metals. As shown in Table X-1 xxxx), the corresponding capital and annual costs (1982 dollars) for this removal are \$1.117 million and \$0.582 million per year, respectively. As shown in Table X-17 (page xxxx), the application of BPT to direct dischargers only will remove approximately 24,220 kg/yr (53,285 lbs/yr) of pollutants. As shown in Table X-2 (page xxxx), the corresponding capital and annual costs (1982 dollars) for this removal are \$87,000 and \$44,000 per year, respectively. The Agency concludes that these pollutant removals justify the costs incurred by plants in this subcategory.

TITANIUM FORMING SUBCATEGORY

Production Operations and Discharge Flows

Production operations that generate process wastewater in the titanium forming subcategory include rolling, drawing, extrusion,

forging, tube reducing, heat treatment, surface treatment, alkaline cleaning, molten salt treatment, tumbling, sawing, grinding, product testing, degreasing and various miscellaneous operations. The wet scrubbers used for air pollution control at some plants are also a source of process wastewater. Water use practices, wastewater streams, and wastewater discharge flows from these operations were discussed in Section V. This information provided the basis for development of the BPT regulatory flow allowances summarized in Table IX-21. The following paragraphs discuss the basis for the BPT flow allowances for each waste stream.

Rolling

Rolling is performed at 16 plants in the titanium forming subcategory. The following information is available from these plants:

Number of plants and operations using neat oil lubricant: 2
Number of plants and operations using contact cooling water: 4.
No lubricants or contact cooling water were reported to be used at approximately 10 plants.

Titanium Rolling Spent Neat Oils. No neat oils are discharged from either of the operations reporting the use of this lubricant. As previously discussed, should a plant need to dispose of this stream, it would be better to remove the neat oils directly by contract hauling and not to discharge them than to commingle the neat oils with wastewater streams and remove them later using an oil-water separation process. Therefore, this waste stream should not be discharged.

Titanium Rolling Contact Cooling Water. Reliable flow data were only available for one of the four rolling operations which use contact cooling water. No recycle is practiced in this operation. The BPT flow of 4,880 l/kg (1,170 gal/ton) is based on the production normalized water use for the operation.

Drawing

Drawing is performed at six titanium forming plants. Two plants reported using neat oil lubricants in a total of two operations. No lubricants were reported to be used at the other four plants.

Titanium Drawing Spent Neat Oils. Spent neat oils from both operations reporting the use of this lubricant are contract hauled to treatment and disposal off-site. It is better to handle the neat oils in this manner rather than to commingle them with wastewater streams and then remove them later using an oil-water separation process. Therefore, this waste stream should not be discharged.

Extrusion

Extrusion is performed at nine plants in this subcategory. The following information is available from these plants:

Number of plants and operations using neat oil lubricant: 5
Number of plants and operations using emulsion lubricant: 1
Number of plants and operations with hydraulic fluid leakage: 1
Three plants did not report the use of lubricants or hydraulic fluid leakage.

Titanium Extrusion Spent Neat Oils. Neat oils are not discharged from any of the five extrusion operations using a neat oil lubricant. The only loss of neat oil is through evaporation and drag-out. Should a plant from these operations need to dispose of this stream, it would be better to remove the neat oils directly by contract hauling rather than to combine them with wastewater streams and remove them later by oil-water separation. Therefore, this waste stream should not be discharged.

Titanium Extrusion Spent Emulsions. One plant reported discharging spent emulsion lubricants from an extrusion operation. No recycle of the emulsion is practiced in this operation. The BPT regulatory flow of 71.9 l/kg (17.2 gal/ton) is based on the production normalized discharge flow from the operation.

Titanium Extrusion Press Hydraulic Fluid Leakage. The BPT regulatory flow of 178 l/kg (42.8 gal/ton) is based on the production normalized discharge flow from the only plant which reported this stream.

Forging

Forging is performed at 32 titanium forming plants. The following information is available from these plants:

Number of plants and operations using lubricants: 7 plants, 8 operations
Number of plants and operations using contact cooling water: 4
Number of plants and operations with equipment cleaning wastewater: 1 plant, 2 operations
Number of plants and operations with hydraulic fluid leakage: 2.
Over 20 plants from this subcategory reported that no waste streams were generated from forging operations.

Titanium Forging Spent Lubricants. The lubricants in seven of the eight operations are consumed during forging and the lubricants from the other operation are contract hauled. The forging lubricants are typically neat oils. As discussed previously, it is better to remove neat oils directly by contract hauling and not to discharge the stream rather than to commingle them with wastewater streams and then remove them later by oil-water separation. Therefore, this waste stream should not be discharged.

Titanium Forging Contact Cooling Water. Flow information is available for three of the four forging operations which use contact cooling water. In one operation 95 percent of the cooling water is recycled; no recycle is practiced for the other

two operations. The BPT regulatory flow of 2,000 l/kg (479 gal/ton) is based on the average production normalized water use for the three operations.

Titanium Forging Equipment Cleaning Wastewater. No recycle is practiced for either of the two reported equipment cleaning operations. The BPT regulatory flow of 40.0 l/kg (9.60 gal/ton) is based on the average production normalized discharge flow from the two operations.

Titanium Forging Press Hydraulic Fluid Leakage. Flow data are available for one of the forging operations where hydraulic fluid leakage was reported. The BPT regulatory flow of 1,010 l/kg (242 gal/ton) is based on the production normalized discharge flow from this operation.

Tube Reducing

Titanium Tube Reducing Spent Lubricants. One of the lubricants used in reducing titanium tubes is a neat oil. Since neat oils contain no water, the Agency believes that it is better to haul the oil directly and not to commingle it with wastewater streams only to remove it later. Other titanium tube reducing lubricants are emulsions. A tube reducing emulsion was sampled at a nickel forming plant. Analysis of the sampled tube reducing lubricant showed treatable concentrations of N-nitrosodiphenylamine, a toxic organic pollutant with potentially carcinogenic properties. If one nitrosamine compound is present in this wastewater source then there are likely to be other compounds or other nitrosamine compounds could be formed as this compound most likely was in the presence of precursors, under the conditions created by the tube reducing process. Therefore, there shall be no discharge of titanium tube reducing lubricant.

Heat Treatment

Ten plants reported using contact cooling water in 10 heat treatment operations.

Titanium Heat Treatment Contact Cooling Water. No BPT discharge allowance is provided for this stream. The zero discharge allowance is based on 100 percent reuse of this wastewater, either as heat treatment contact cooling water or in other processes present at the titanium forming plant. Analysis of a similar nickel forming waste stream, "Annealing and Solution Heat Treatment Contact Cooling Water," indicated that the wastewater did not contain any treatable concentrations of pollutants. Therefore, reuse of the wastewater is possible. Furthermore, reuse of nickel annealing and solution heat treatment contact cooling water is demonstrated at three plants. Because titanium heat treatment contact cooling water contains pollutants at concentrations similar to nickel annealing and solution heat treatment contact cooling water (since the processes are similar), there is no discharge allowance for titanium heat treatment contact cooling based on the reuse of this wastewater stream.

Surface Treatment

Twenty-one plants reported information on surface treatment operations. A total of 32 surface treatment baths and 29 surface treatment rinse operations were reported.

Titanium Surface Treatment Spent Baths. Flow data were available for 21 baths which are either discharged or contract hauled. The BPT regulatory flow of 208 l/kg (49.9 gal/ton) is based on the median production normalized discharge flow of the 21 baths. The median is believed to be a better representation of the current discharge from this operation than the average because of the large range of reported production normalized discharge flows (1.71 l/kg to 1,310 l/kg).

Titanium Surface Treatment Rinse. Countercurrent cascade rinsing is not practiced in any of the rinse operations. In one operation 40 percent of the rinse is recycled while rinsewater is only periodically discharged from five operations. The BPT regulatory flow of 29,200 l/kg (7,000 gal/ton) is based on the average of 16 of 19 reported production normalized rinse application rates. Three reported values were not used to calculate the average because they are much larger than the other values. Therefore, the Agency does not believe that these outlying values are representative of current typical water use for this operation.

Alkaline Cleaning

Six plants supplied information on alkaline cleaning operations. All six plants discharge spent cleaning baths and rinse.

Titanium Alkaline Cleaning Spent Baths. Flow data were available for seven of the eight reported baths. The BPT regulatory flow of 240 l/kg (57.5 gal/ton) is the median production normalized discharge flow of the seven reported wastewater discharges. The median is believed to be a better representation of the current typical discharge for this operation than the average because of the large range of reported production normalized discharge flows (52.1 l/kg to 9,810 l/kg).

Titanium Alkaline Cleaning Rinse. Flow data were available for six of the seven reported rinse operations. No recycle or other flow reduction practices were used in any of these operations. The BPT regulatory flow of 2,760 l/kg (663 gal/ton) is based on the median production normalized water use from four operations. Two operations with very high flows were not included in the calculation. Both of these very high flows came from operations described as "Free-Flowing Rinses." Because this is the least efficient type of rinsing, in terms of water use, the two operations were excluded from the determination of current typical practice used for the BPT allowance. The median is believed to be a better representation of the current typical water use for this operation than the average (arithmetic mean)

because of the large range of rinse flows even after excluding the two high values (348 l/kg to 82,300 l/kg).

Molten Salt Treatment

Titanium Molten Salt Rinse. One plant reported generating rinse from a molten salt treatment operation. The BPT regulatory flow of 955 l/kg (229 gal/ton) is based on the production normalized discharge flow from this operation.

Tumbling

Titanium Tumbling Wastewater. One plant reported generating wastewater from a titanium tumbling operation. The wastewater from this operation is discharged on a once-through basis. The

BPT discharge flow of 790 l/kg (189 gal/ton) is based on the production normalized water use for this operation.

Sawing or Grinding

Thirteen plants reported generating wastewater from sawing or grinding operations. The following information is available from these plants:

Number of plants and operations using neat oil lubricant: 2

Number of plants and operations using emulsions and synthetic coolants: 11 plants, 19 operations

Number of plants and operations using contact cooling water: 1.

Titanium Sawing or Grinding Spent Neat Oils. In one operation, the only loss of neat oils occurs through evaporation and drag-out. Spent neat oils from the other operation are contract hauled to treatment and disposal off-site. It is better to remove neat oils directly by contract hauling than to commingle the oils with wastewater streams only to remove them later using an oil-water separation process. Therefore, this waste stream should not be discharged.

Titanium Sawing or Grinding Spent Emulsions and Synthetic Coolants. In this subcategory, these lubricants are either completely recycled with no discharge or recycled with periodic batch discharges. The lubricants in four operations are completely recycled with no discharge. In four other operations the only loss of lubricant is through evaporation and drag-out. Lubricant is periodically dumped from seven operations. Flow data were available for six of the operations which discharge spent emulsions and synthetic coolants. Recycle with periodic batch discharges is practiced in four of these operations while no recycle is used for the other two operations. The BPT regulatory flow of 183 l/kg (43.8 gal/ton) is based on the average production normalized discharge flow from these six operations. The four recycle operations were included in the calculation since recycle is current typical industry practice.

Titanium Sawing or Grinding Contact Cooling Water. The use of contact cooling water was reported for only one operation. Cooling water is discharged on a once-through basis from this operation. The BPT regulatory flow of 4,760 l/kg (1,140 gal/ton) is based on the production normalized water use for this operation.

Product Testing

Titanium Dye Penetrant Testing Wastewater. Wastewater is generated from six dye penetrant testing operations. Flow data are available for two of these operations. The BPT regulatory flow of 1,120 l/kg (268 gal/ton) is based on the average production normalized discharge flow from these two operations.

Miscellaneous Wastewater Sources

Titanium Miscellaneous Wastewater Sources. Miscellaneous wastewater sources identified in this subcategory include wastewater from cleaning tools, hydrotesting wastewater, and spillage from an abrasive saw area. Discharge data were only available for the tool cleaning and hydrotesting operations. The BPT regulatory flow of 32.4 l/kg (7.77 gal/ton) is based on the production normalized discharge flow from the tool cleaning operation. Hydrotesting wastewater is not included in the basis because the Agency believes that hydrotesting wastewater should not be discharged, but should be reused for hydrotesting or other forming operations.

Degreasing

Titanium Degreasing Spent Solvents. Only a small number of surveyed plants with solvent degreasing operations have process wastewater streams associated with the operation. Because most plants practice solvent degreasing without wastewater discharge, the Agency believes zero discharge of wastewater is an appropriate discharge limitation.

Wet Air Pollution Control

Titanium Wet Air Pollution Control Blowdown. Titanium forming plants reported using wet air pollution control devices to control air emissions from forging and surface treatment operations. Ninety percent or greater recycle of the scrubber water is practiced by five of the 14 reported operations and only periodic batch discharges were reported for another operation. Scrubber water is discharged on a once-through basis from five operations. No flow data are available for the remaining three operations. The BPT regulatory flow of 2,140 l/kg (514 gal/ton) is based on the median production normalized water use from the 11 operations for which water use data were available. The median is believed to be a better representation of the current typical water use than the average (arithmetic mean) because of the large range of production normalized water uses from the 11 operations (88.1 l/kg to 554,000 l/kg).

Deleted Waste Streams

Titanium Cold Rolling Spent Lubricants. Following proposal, the Agency received additional data and conducted a review of all available data concerning wastewater discharges in this subcategory. This review led to a reinterpretation of some data reported prior to proposal. As a result, the Cold Rolling Spent Lubricant waste stream included in the proposed regulation for this subcategory has been deleted from the final regulation. All data included under Cold Rolling Spent Lubricants at proposal, have been reclassified under other waste streams in this subcategory for the final regulation.

Regulated Pollutants

The priority pollutants considered for regulation under BPT are listed in Section VI along with an explanation of why they have been considered. The pollutants selected for regulation under BPT are lead, zinc, cyanide, ammonia, fluoride, oil and grease, total suspended solids, and pH. The priority metals chromium, copper, and nickel, and the nonconventional pollutant titanium are not specifically regulated under BPT for the reasons explained in Section X. The basis for regulating oil and grease, total suspended solids and pH under BPT was discussed earlier in this section. The basis for regulating lead, zinc, cyanide, ammonia, and fluoride is discussed below.

Lead is selected for regulation since it was found at treatable concentrations in 18 of 21 raw wastewater samples. Lead was present at treatable concentrations in all raw wastewater streams in which it was analyzed. These streams are rolling contact cooling water, surface treatment spent baths, surface treatment rinse, molten salt rinse, tumbling wastewater, dye penetrant testing wastewater, wet air pollution control blowdown and sawing or grinding spent emulsions and synthetic coolants.

Zinc is selected for regulation since it was found at treatable concentrations in 10 of 21 raw wastewater samples. Zinc was present at treatable concentrations in seven of the eight raw wastewater streams in which it was analyzed.

Cyanide is selected for regulation since it was found at treatable concentrations in rolling contact cooling water, tumbling wastewater, dye penetrant testing wastewater, and sawing or grinding spent emulsions and synthetic coolants. Preliminary cyanide precipitation is needed to remove this pollutant from wastewater. Therefore, regulation of cyanide is appropriate for the titanium forming subcategory.

Ammonia is selected for regulation since it was found at treatable concentrations in surface treatment rinse and tumbling wastewater. Preliminary ammonia steam stripping is needed to remove ammonia from these wastewaters. Therefore, regulation of ammonia is appropriate for the titanium forming subcategory.

Fluoride is selected for regulation since it was found at treatable concentrations in 17 of 22 raw wastewater samples and seven of the eight raw wastewater streams in which it was analyzed.

Treatment Train

The BPT model treatment train for the titanium forming subcategory consists of preliminary treatment when necessary, specifically chemical emulsion breaking and oil skimming, cyanide precipitation, and ammonia steam stripping. The effluent from preliminary treatment is combined with other wastewater for common treatment by oil skimming and lime and settle. Waste streams potentially needing preliminary treatment are listed in

Table IX-6. Figure IX-1 presents a schematic of the general treatment train for the nonferrous metals forming category.

Effluent Limitations

The pollutant mass discharge limitations (milligrams of pollutant per off-kilogram of PNP) were calculated by multiplying the BPT regulatory flows summarized in Table IX-21 (l/kkg) by the concentration achievable by the BPT model treatment system summarized in Table VII-21 (mg/l) for each pollutant parameter considered for regulation at BPT ($l/kkg \times mg/l \times kkg/1,000 \text{ kg} = mg/off\text{-kg}$). The results of this computation for all waste streams and regulated pollutants in the titanium forming subcategory are summarized in Table IX-22. Although no limitations have been established for titanium, Table IX-22 includes titanium mass discharge limitations attainable using the BPT model technology. These limitations are presented as guidance for permit writers. This limitation table lists all the pollutants which were considered for regulation. Those specifically regulated are marked with an asterisk.

Costs and Benefits

In establishing BPT, EPA must consider the cost of treatment and control in relation to the effluent reduction benefits. BPT costs and benefits are tabulated along with BAT costs and benefits in Section X. As shown in Table X-8 (page xxxx), the application of BPT to the total titanium forming subcategory will remove approximately 350,650 kg/yr (771,430 lbs/yr) of pollutants, including 300 kg/yr (660 lbs/yr) of toxic metals. As shown in Table X-1, the corresponding capital and annual costs (1982 dollars) for this removal are \$2.879 million and \$2.571 million per year, respectively. As shown in Table X-18 (page xxxx), the application of BPT to direct dischargers only will remove approximately 105,460 kg/yr (232,010 lbs/yr) of pollutants including 90 kg/yr (200 lbs/yr) of toxic metals. As shown in Table X-2 (page xxxx), the corresponding capital and annual costs (1982 dollars) for this removal are \$2.238 million and \$2.261 million per year, respectively. The Agency concludes that these

pollutant removals justify the costs incurred by plants in this subcategory.

URANIUM FORMING SUBCATEGORY

Production Operations and Discharge Flows

Production operations that generate process wastewater in the uranium forming subcategory include extrusion, forging, heat treatment, surface treatment, sawing, grinding, area cleaning, drum washing, on-site laundries, and degreasing. The wet scrubbers used for air pollution control at some plants are also a source of process wastewater. Water use practices, wastewater streams, and wastewater discharge flows from these operations were discussed in Section V. This information provided the basis for development of the BPT regulatory flow allowances summarized in Table IX-23. The following paragraphs discuss the basis for the BPT flow allowances for each waste stream.

Extrusion

Extrusion is performed at one uranium forming plant. The following information was reported on extrusion operations by this plant:

Number of operations: 1
Number of operations using lubricants: 1
Number of operations using contact cooling water: 1.

Uranium Extrusion Spent Lubricants. No lubricants are discharged from the one uranium extrusion operation where their use was reported. Extrusion lubricants are typically neat oils. Should a uranium forming plant need to dispose of a spent neat oil stream, it would be better to remove the stream directly by contract hauling rather than to commingle the oil with wastewater streams only to remove it later using an oil-water separation process. Therefore, this waste stream should not be discharged.

Uranium Extrusion Tool Contact Cooling Water. One plant reported using contact cooling water to quench extrusion tools. No recycle is practiced for this operation. The BPT discharge allowance is the production normalized water use from the operation, 344 l/kg (82.5 gal/ton).

Forging

The following information was reported on forging operations in this subcategory:

Number of plants: 1
Number of operations: 1
Number of operations using lubricants: 1.

Uranium Forging Spent Lubricants. No lubricants are discharged from the only reported forging operation. The only loss of lubricant from this operation is due to evaporation and drag-out. Forging lubricants are typically neat oils. As previously discussed, should a plant need to dispose of the oil, it would be better to remove the oil directly by contract hauling rather than to commingle it with other wastewaters only to remove it later using an oil-water separation process. Therefore, this waste stream should not be discharged.

Heat Treatment

Two plants reported using contact cooling water in a total of five heat treatment operations.

Uranium Heat Treatment Contact Cooling Water. In three operations, the cooling water is periodically batch discharged. The cooling water is discharged on a once-through basis from two operations. The BPT regulatory flow of 1,900 l/kg (455 gal/ton) is based on the average production normalized water use from these two operations.

Surface Treatment

All three uranium forming plants provided information on surface treatment operations. Three surface treatment baths and two surface treatment rinse operations were reported.

Uranium Surface Treatment Spent Baths. Flow data were available for one of the three surface treatment bath operations. The BPT regulatory flow of 27.2 l/kg (6.52 gal/ton) is based on the production normalized discharge flow from this bath.

Uranium Surface Treatment Rinse. Flow data were available for each of the two reported rinse operations. Although neither countercurrent cascade rinsing nor recycle is practiced in either rinse operation, water use for both operations is low, indicating conservative water use. The BPT regulatory flow of 337 l/kg (80.9 gal/ton) is based on the average production normalized discharge flow from the two operations.

Sawing or Grinding

Uranium Sawing or Grinding Spent Emulsions. Lubricating emulsions are used in three operations. In all three operations, spent emulsions are periodically discharged. Discharge flow data were available for two of the operations. The BPT regulatory flow of 5.68 l/kg (1.36 gal/ton) is based on the average production normalized discharge flow from the two operations.

Uranium Sawing or Grinding Contact Cooling Water. One plant reported using contact cooling water to quench parts following a shear cutting operation. No information on recycle or other flow reduction practices was reported for this operation. The BPT regulatory flow of 1,650 l/kg (395 gal/ton) is based on the

production normalized discharge flow from the quenching operation.

Uranium Sawing or Grinding Rinse. One plant reported using a stagnant rinse after a sawing operation. The stagnant rinse is periodically discharged. The BPT regulatory flow is the production normalized discharge flow from the stagnant rinse, 4.65 l/kg (1.12 gal/ton).

Area Cleaning

Uranium Area Cleaning Wastewater. One plant reported discharging wastewater from cleanup operations in three different areas of the plant. The BPT regulatory flow of 42.9 l/kg (10.3 gal/ton) is based on the average production normalized discharge flow from the three cleanup operations.

Degreasing

Uranium Degreasing Spent Solvents. Only a small number of surveyed plants with solvent degreasing operations have process wastewater streams associated with the operation. Because most plants practice solvent degreasing without wastewater discharge, the Agency believes zero discharge of wastewater is an appropriate discharge limitation.

Wet Air Pollution Control

Uranium Wet Air Pollution Control Blowdown. Two plants reported using wet air pollution control scrubber devices to control air emissions from surface treatment operations. No wastewater is discharged from one scrubber operation. Wastewater is only periodically discharged from the other operation. The BPT regulatory flow of 3.49 l/kg (0.836 gal/ton) is based on the production normalized discharge flow from this operation.

Drum Wash

Uranium Drum Washwater. One plant reported washing solid waste drums before they were contract hauled to off-site disposal. The BPT regulatory flow of 44.3 l/kg (10.6 gal/ton) is based on the production normalized discharge flow from this operation.

Laundry

Uranium Laundry Washwater. Wastewater from the on-site laundering of employee uniforms is generated at one plant. The Agency established the normalizing parameter for this building block as the number of employees, not a unit of production. The BPT regulatory flow of 52.4 l/employee-day (12.6 gal/employee-day) is based on the water use for the one reported operation.

Regulated Pollutants

The priority pollutants considered for regulation under BPT are listed in Section VI along with an explanation of why they have been considered. The pollutants selected for regulation under BPT are cadmium, total chromium, copper, nickel, fluoride, molybdenum, oil and grease, total suspended solids, and pH. The priority pollutants lead and zinc, and the nonconventional pollutants uranium and radium-226 are not specifically regulated for the reasons explained in Section X. The basis for regulating oil and grease, total suspended solids, and pH under BPT was discussed earlier in this section. The basis for regulating cadmium, chromium, copper, nickel, fluoride, and molybdenum is discussed below.

Cadmium is selected for regulation since it was found at treatable concentrations in seven of 14 raw wastewater samples and four of the eight raw wastewater streams in which it was analyzed. Treatable concentrations of cadmium were found in surface treatment spent baths, surface treatment rinse, area cleaning wastewater and sawing, grinding spent emulsions.

Total chromium is selected for regulation since it was present at treatable concentrations in seven of 14 raw wastewater samples and five of the eight raw wastewater streams in which it was analyzed. Treatable concentrations of total chromium were found in heat treatment contact cooling water, surface treatment spent baths, surface treatment rinse, area cleaning wastewater and sawing or grinding spent emulsions. Total chromium includes both the trivalent and hexavalent forms of chromium. Only the trivalent form is effectively removed by lime and settle technology. Hexavalent chromium, which may be present in wastewaters such as surface treatment spent baths and surface treatment rinse, must be reduced to the trivalent form by preliminary chromium reduction treatment in order to meet the limitation on total chromium in this subcategory. Therefore, regulation of total chromium is appropriate for the uranium forming subcategory.

Copper is selected for regulation since it was found at treatable concentrations in 10 of 14 raw wastewater samples and six of the eight raw wastewater streams in which it was analyzed. Copper was found at treatable concentrations in all of the waste streams listed in the previous paragraph for chromium, and it was also present at treatable concentrations in drum washwater.

Lead is selected for regulation since it was found at treatable concentrations in 13 of 14 raw wastewater samples and seven of the eight raw wastewater streams in which it was analyzed. Lead was found at treatable concentrations in all of the waste streams listed in the previous paragraph for chromium, and it was also present at treatable concentrations in drum washwater and surface treatment wet air pollution control blowdown.

Nickel is selected for regulation since it was found at treatable concentrations in eight of 14 raw wastewater samples and four of

the eight raw wastewater streams in which it was analyzed. Treatable concentrations of nickel were present in heat treatment contact cooling water, surface treatment spent baths, surface treatment rinse, and area cleaning wastewater.

Fluoride is selected for regulation since it was present at treatable concentrations in one of 14 raw wastewater samples and one of eight raw wastewater streams in which it was analyzed. Fluoride is specifically regulated under BPT because it will not be adequately removed by the technology (lime and settle) required for the removal of the regulated priority metals pollutants, copper and nickel.

Molybdenum is selected for regulation since it was present at treatable concentrations in three of 14 raw wastewater samples and two of the eight raw wastewater streams in which it was analyzed. Molybdenum is specifically regulated under BPT because it will not be adequately removed by the technology (lime and settle) required for the removal of the regulated priority metal pollutants, copper and nickel. The addition of iron to a lime and settle system (i.e., iron coprecipitation) is necessary for efficient removal of molybdenum. Regulation of priority metals only is not sufficient to ensure the removal of molybdenum from uranium forming wastewater.

Treatment Train

The BPT model treatment train for the uranium forming subcategory consists of preliminary treatment when necessary, specifically chromium reduction, and chemical emulsion breaking and oil skimming. The effluent from preliminary treatment is combined with other wastewater for common treatment by oil skimming, iron coprecipitation, and lime and settle. Waste streams potentially needing preliminary treatment are listed in Table IX-7. Figure IX-1 presents a schematic of the general BPT treatment train for the nonferrous metals forming category.

Effluent Limitations

The pollutant mass discharge limitations (milligrams of pollutant per off-kilogram of PNP) were calculated by multiplying the BPT regulatory flows summarized in Table IX-23 (l/kg) by the concentration achievable by the BPT model treatment system summarized in Table VII-21 (mg/l) for each pollutant parameter considered for regulation at BPT ($l/kg \times mg/l \times kkg/1,000 kg = mg/off-kg$). The results of this computation for all waste streams and regulated pollutants in the uranium forming subcategory are summarized in Table IX-24. Although no limitations have been established for uranium, Table IX-24 includes uranium mass discharge limitations attainable using the BPT model technology. These limitations are presented for the guidance of permit writers. The limitations table lists all the pollutants which were considered for regulation. Those specifically regulated are marked with an asterisk.

Costs and Benefits

In establishing BPT, EPA must consider the cost of treatment and control and the pollutant reduction benefits to evaluate economic achievability. As shown in Table X-9 (page xxxx), the application of BPT to the total uranium forming subcategory will remove approximately 23,100 kg/yr (50,820 lbs/yr) of pollutants including 46 kg/yr (100 lbs/yr) of toxic pollutants. The application of BPT to direct dischargers will remove the same amount of pollutants since all uranium forming plants are direct dischargers. Since there are only two plants in this subcategory, total subcategory and direct discharger capital and annual costs will not be reported in this document in order to protect confidentiality claims. The Agency concludes that the pollutant removals justify the costs incurred by plants in this subcategory.

ZINC FORMING SUBCATEGORY

Production Operations and Discharge Flows

Production operations that generate process wastewater in the zinc forming subcategory include rolling, drawing, direct chill casting, stationary casting, annealing heat treatment, surface treatment, alkaline cleaning, sawing, grinding, degreasing, and electroplating. Water use practices, wastewater streams, and wastewater discharge flows from these operations were discussed in Section V. This information provided the basis for development of the BPT regulatory flow allowances summarized in Table IX-25. The following paragraphs discuss the basis for the BPT flow allowances for each waste stream.

Rolling

Rolling is performed at four zinc forming plants. The following information is available from these plants:

Number of plants and operations using neat oil lubricant:	1
Number of plants and operations using emulsion lubricant:	3
Number of plants and operations using contact cooling water:	1

plant, 2 operations.

Zinc Rolling Spent Neat Oils. The one rolling operation that uses a neat oil lubricant does not discharge any of the lubricant. Drag-out on the product surface accounts for the only loss. Should the plant ever need to dispose the neat oil, it would be better to remove the oil directly by contract hauling and not to discharge the stream. Therefore, this waste stream should not be discharged.

Zinc Rolling Spent Emulsions. The spent emulsion from one of the three operations is applied to land; the spent emulsion from another operation is contract hauled; and the spent emulsion from the third operation is treated on-site and the water fraction is completely reused. As discussed previously for rolling spent emulsions in the lead-tin-bismuth forming subcategory, spent

emulsions are often treated on-site and the water discharged (with the oil fraction contract hauled). Therefore, EPA is providing a discharge allowance. The BPT discharge allowance is 1.39 l/kg (0.334 gal/ton), the only reported production normalized flow.

Zinc Rolling Contact Cooling Water. Flow data were available for two of the three rolling operations where the use of contact cooling water was reported. Contact cooling water is discharged on a once-through basis from both operations. The BPT regulatory flow of 536 l/kg (129 gal/ton) is based on the average production normalized water use from the two operations.

Drawing

Drawing is performed at seven plants in this subcategory. Four plants reported the use of emulsion lubricants in a total of four drawing operations.

Zinc Drawing Spent Emulsions. The spent emulsion from two of the four operations is contract hauled and the spent emulsion from two operations is treated on-site and the water fraction is discharged. Flow data were available for one of the four operations. The BPT regulatory flow of 5.80 l/kg (1.39 gal/ton) is based on the production normalized discharge flow from this operation.

Casting

Casting is performed at six zinc forming plants. The following information is available from these plants:

Number of plants and operations with direct chill casting using contact cooling water: 2
Number of plants and operations with stationary casting using contact cooling water: 1
Number of plants and operations with continuous casting: 2
Number dry: 2.

Zinc Direct Chill Casting Contact Cooling Water. The contact cooling water from one operation is completely recycled with no discharge; the contact cooling water from the other operation is discharged with no recycle. The BPT discharge allowance is 505 l/kg (121 gal/ton), the production normalized water use for the one reported non-zero discharge operation.

Zinc Stationary Casting Contact Cooling Water. The contact cooling water in the one operation is completely evaporated. Therefore, the BPT discharge allowance is zero.

Heat Treatment

The following information was reported on heat treatment operations in this subcategory:

Number of plants: 1
Number of operations: 1
Number of operations using contact cooling water: 1.

Zinc Annealing Heat Treatment Contact Cooling Water. The contact cooling water in the one operation is batch dumped daily. The BPT discharge allowance is 763 l/kg (183 gal/ton), the production normalized discharge flow from the one operation.

Surface Treatment

Two plants provided information on zinc surface treatment operations. Four surface treatment baths and three surface treatment rinse operations were reported.

Zinc Surface Treatment Spent Baths. Discharge flow data were available for three of the four baths. The BPT discharge allowance of 88.7 l/kg (21.3 gal/ton) is based on the average production normalized discharge flow from the three operations.

Zinc Surface Treatment Rinse. Neither countercurrent cascade rinsing or recycle was reported for any of the three surface treatment rinse operations. The BPT regulatory flow of 3,580 l/kg is based on the average production normalized water use for the three operations.

Alkaline Cleaning

Two plants supplied information on alkaline cleaning. At each plant, an alkaline cleaning bath is followed by a rinse.

Zinc Alkaline Cleaning Spent Baths. The BPT regulatory flow of 3.55 l/kg (0.850 gal/ton) is based on the average production normalized discharge flow from the two alkaline cleaning bath operations.

Zinc Alkaline Cleaning Rinse. Two stage countercurrent cascade rinsing is utilized in one operation and spray rinsing is practiced in the other operation. Both of these rinsing methods reduce water use compared to traditional rinsing methods. The BPT discharge flow of 1,690 l/kg (405 gal/ton) is based on the average production normalized discharge flow from the two operations.

Sawing or Grinding

Zinc Sawing or Grinding Spent Emulsions. One plant provided information on grinding zinc. An emulsion is used as a lubricant in the grinding operation. The emulsion is completely recirculated and periodically batch dumped. The BPT discharge allowance is 23.8 l/kg (5.71 gal/ton), the production normalized discharge flow from the operation.

Degreasing

Zinc Degreasing Spent Solvent. Only a small number of surveyed plants with solvent degreasing operations have process wastewater streams associated with the operation. Because most plants practice solvent degreasing without wastewater discharge, the Agency believes zero discharge of wastewater is an appropriate discharge limitation.

Electrocoating

Zinc Electrocoating Rinse. One plant reported discharging wastewater from an electrocoating rinse operation. The BPT discharge allowance of 2,290 l/kg (550 gal/ton) is based on the production normalized water use for the rinse operation.

Regulated Pollutants

The priority pollutants considered for regulation under BPT are listed in Section VI along with an explanation of why they were considered. The pollutants selected for regulation under BPT are total chromium, copper, zinc, cyanide, oil and grease, total suspended solids, and pH. The priority pollutant nickel, listed in Section VI as selected for further consideration, is not specifically regulated under BPT for the reasons explained in Section X. The basis for regulating oil and grease, total suspended solids, and pH was discussed earlier in this section. The basis for regulating total chromium, copper, zinc, and cyanide is discussed below.

Total chromium is selected for regulation since it was found above treatability in a surface treatment rinse sample and the Agency believes it is also present at treatable concentrations in surface treatment spent baths. Surface treatment baths and rinse may contain the hexavalent form of chromium which must be reduced by the trivalent form by preliminary chromium reduction before mium is appropriate for this subcategory.

Copper is selected for regulation since the Agency believes that treatable concentrations of copper may be present in raw wastewater streams such as electrocoating rinse. In one electrocoating operation reported in this subcategory, copper is plated onto zinc. Therefore, the electrocoating rinse from this operation is likely to contain treatable copper concentrations.

Zinc is selected for regulation since it was found at treatable concentrations in both raw wastewater streams in which it was analyzed and it is the metal being formed in this subcategory. In addition, the Agency believes that other raw wastewater streams may contain treatable zinc concentrations.

Cyanide is selected for regulation since it was found above its treatable concentration in an alkaline cleaning rinse sample and is a process chemical used in the electrocoating process. Preliminary cyanide precipitation treatment is needed to remove

cyanide from wastewater. Therefore, regulation of cyanide in the zinc forming subcategory is appropriate.

Treatment Train

The BPT model treatment train for the zinc forming subcategory consists of preliminary treatment when necessary, specifically chromium reduction, chemical emulsion breaking and oil skimming, and cyanide precipitation. The effluent from preliminary treatment is combined with other wastewater for common treatment by oil skimming, and lime and settle. Waste streams potentially needing preliminary treatment are listed in Table IX-8. Figure IX-1 presents a schematic of the general BPT treatment train for the nonferrous metals forming category.

Effluent Limitations

The pollutant mass discharge limitations (milligrams of pollutant per off-kilogram of PNP) were calculated by multiplying the BPT regulatory flows summarized in Table IX-25 (l/kg) by the concentration achievable by the BPT model treatment system summarized in Table VII-21 (mg/l) for each pollutant parameter considered for regulation at BPT ($l/kg \times mg/l \times kkg/l,000 \text{ kg} = mg/off\text{-kg}$). The results of this computation for all waste streams and regulated pollutants in the zinc forming subcategory are summarized in Table IX-26. This limitations table lists all the pollutants which were considered for regulation and those specifically regulated are marked with an asterisk.

Costs and Benefits

In establishing BPT, EPA considered the cost of treatment and control and the pollutant reduction benefits to evaluate economic achievability. As shown in Table X-10 (page xxxx), the application of BPT to the total zinc forming subcategory will remove approximately 308,260 kg/yr (678,170 lbs/yr) of pollutants including 262,210 kg/yr (576,860 lbs/yr) of toxic pollutants. As shown in Table X-20 (page xxxx), the application of BPT to direct dischargers only will remove approximately 307,400 kg/yr (676,280 lbs/yr) of pollutants including 262,150 kg/yr (576,730 lbs/yr) of toxic pollutants. Since there is only one direct discharge plant in this subcategory, total subcategory capital and annual costs and direct discharger capital and annual costs will not be reported in this document in order to protect confidentiality claims. The Agency concludes that the pollutant removals justify the costs incurred by plants in this subcategory.

ZIRCONIUM-HAFNIUM FORMING SUBCATEGORY

Production operations that generate process wastewater in the zirconium-hafnium forming subcategory include rolling, drawing, extrusion, swaging, tube reducing, heat treatment, surface treatment, alkaline cleaning, molten salt treatment, sawing, grinding, product testing, and degreasing. The wet scrubbers used for air pollution control at some plants are also a source

of process wastewater. Water use practices, wastewater streams, and wastewater discharge flows from these operations were discussed in Section V. This information provided the basis for development of the BPT regulatory flow allowances summarized in Table IX-27. The following paragraphs discuss the basis for the BPT flow allowances for each waste stream.

Production Operations and Discharge Flows

Rolling

Rolling is performed at seven plants in the zirconium-hafnium forming subcategory. One plant reported using a lubricant in one rolling operation.

Zirconium-Hafnium Rolling Spent Neat Oils. No neat oils are discharged from the one operation. Should the plant ever find the need to dispose the neat oil, it would be better to remove the oil directly by contract hauling rather than to commingle the oil with wastewater streams and remove it later using oil-water separation treatment. Therefore, this waste stream should not be discharged.

Drawing

Drawing is performed at four plants in this subcategory. These plants reported using lubricant in a total of three drawing operations.

Zirconium-Hafnium Drawing Spent Lubricants. The only loss of lubricant in one operation is through evaporation and drag-out; spent lubricants from another operation are contract hauled; no flow information is available for the other operation. Drawing lubricants are typically neat oils. It is better to remove these lubricants directly by contract hauling rather than to commingle the lubricants with wastewater streams only to remove them later. Therefore, this waste stream should not be discharged.

Extrusion

Extrusion is performed at five zirconium-hafnium forming plants. The following information is available from these plants:

Number of plants and operations using lubricants: 4 plants, 5 operations

Number of plants and operations with hydraulic fluid leakage: 1.

Zirconium-Hafnium Extrusion Spent Lubricants. No lubricants are discharged from any of the five operations. Should a plant need to dispose of these lubricants, it would be better to remove them directly by contract hauling rather than commingle the lubricants with wastewater streams and remove them later. Therefore, this waste stream should not be discharged.

Zirconium-Hafnium Extrusion Press Hydraulic Fluid Leakage. One plant reported the discharge of leakage from extrusion presses. Hydraulic fluid leaks result from the moving connection points in high pressure extrusion presses. The BPT discharge allowance of 237 l/kg (56.9 gal/ton) is based on the production normalized discharge flow of leakage from the one operation.

Swaging

Zirconium-Hafnium Swaging Spent Neat Oils. One plant reported using neat oil lubricants in a swaging operation. The only loss of neat oils from this operation is through dragout. Should the plant ever need to dispose of spent neat oils, it would be better to remove the oil directly by contract hauling rather than to combine the neat oil with wastewater streams and then remove it later using oil-water separation treatment. Therefore, this waste stream should not be discharged.

Tube Reducing

Zirconium-Hafnium Tube Reducing Spent Lubricants. There shall be no discharge allowance for the discharge of pollutants from tube reducing spent lubricants, if once each month for six consecutive months the facility owner or operator demonstrate the absence of N-nitrosodi-n-propylamine, N-nitrosodimethylamine, and N-nitrosodiphenylamine by sampling and analyzing spent tube reducing lubricants. If the facility complies with this requirement for six months then the frequency of sampling may be reduced to once each quarter. A facility shall be considered in compliance with this requirement if the concentrations of the three nitrosamine compounds does not exceed the analytical quantification levels set forth in 40 CFR Part 136 which are 0.020 mg/l for N-nitrosodiphenylamine, 0.020 mg/l for N-nitrosodi-n-propylamine, and 0.050 mg/l for N-nitrosodimethylamine.

Heat Treatment

Zirconium-Hafnium Heat Treatment Contact Cooling Water. Contact cooling water is used in six heat treatment operations. Flow information was available for four of these operations. The BPT regulatory flow of 343 l/kg (82.3 gal/ton) is based on the median production normalized water use for the four operations. The median is believed to be a better representation of the current typical water use for this operation than the average (arithmetic mean) because of the large range of reported production normalized water uses (135 l/kg to 6,000 l/kg).

Surface Treatment

Eight plants supplied information on surface treatment operations in the zirconium-hafnium forming subcategory.

Zirconium-Hafnium Surface Treatment Spent Baths. Flow data were available for nine of the 14 reported surface treatment baths. The BPT regulatory flow of 340 l/kg (81.5 gal/ton) is based on

the median production normalized discharge flow of the nine operations. The median is believed to be a better representation of the current typical discharge from this operation than the average (arithmetic mean) because of the large range of production normalized discharge flows (102 l/kkg to 64,300 l/kkg).

Zirconium-Hafnium Surface Treatment Rinse. Flow data were available for 10 of the 12 reported surface treatment rinse operations. Countercurrent cascade rinsing and recycle are not practiced in any of these operations. The BPT regulatory flow of 8,880 l/kkg (2,130 gal/ton) is based on the median production normalized water use for the 10 operations. The median is believed to be a better representation of the current typical water use for this operation than the average (arithmetic mean) because of the large range of production normalized water uses (297 l/kkg to 971,000 l/kkg).

Alkaline Cleaning

Zirconium-Hafnium Alkaline Cleaning Spent Baths. A total of 13 alkaline cleaning bath operations were reported. Flow data were available for 12 of these operations. The BPT regulatory flow of 1,600 l/kkg (384 gal/ton) is based on the average production normalized discharge flow of the 12 operations.

Zirconium-Hafnium Alkaline Cleaning Rinse. Flow data were available for 10 of 11 reported alkaline cleaning rinse operations. Countercurrent cascade rinsing and recycle are not practiced in any of these operations. The BPT regulatory flow of 31,400 l/kkg (7,530 gal/ton) is based on the average production normalized water use for the 10 operations.

Molten Salt Treatment

Zirconium-Hafnium Molten Salt Rinse. Two plants reported discharging molten salt rinse. Neither plant practices countercurrent cascade rinsing or recycle of the rinse, however the water use for one plant was very low (only 20.86 l/kkg). The BPT regulatory flow of 7,560 l/kkg (1,810 gal/ton) is based on the average production normalized water use for the two operations.

Sawing or Grinding

Zirconium-Hafnium Sawing or Grinding Spent Neat Oils. The use of a neat oil lubricant was reported for only one operation. The only loss of lubricant from this operation is through drag-out. Should spent neat oil from this operation ever need to be disposed, it would be better to contract haul the lubricant directly and not to discharge the stream. Therefore, this waste stream should not be discharged.

Zirconium-Hafnium Sawing or Grinding Spent Emulsions. The use of emulsion lubricants was reported for seven operations. No flow data were available for three operations; the only loss of

emulsion from three other operations is from evaporation and drag-out; flow data were available for one operation in which spent emulsion is periodically discharged to an evaporation pond. Since spent emulsions are often treated on-site and the water fraction discharged (with the oil fraction reused or contract hauled), EPA is allowing a discharge for this waste stream. The BPT regulatory flow of 281 l/kg (67.2 gal/ton) is based on the production normalized discharge flow for the one operation which discharges spent emulsion to an evaporation pond.

Zirconium-Hafnium Sawing or Grinding Contact Cooling Water. Flow data were available for one of the two operations where the use of contact cooling water was reported. The BPT regulatory flow of 321 l/kg (77.0 gal/ton) is based on the production normalized discharge flow from this operation.

Zirconium-Hafnium Sawing or Grinding Rinse. Products are sometimes rinsed following grit blasting and belt polishing operations. Four rinse operations were reported in this subcategory. No recycle is practiced in any of these operations. The BPT regulatory flow of 1,800 l/kg (431 gal/ton) is based on the median production normalized water use for the four operations. The median is believed to be a better representation of the current typical water use for this operation than the average (arithmetic mean) because of the large range of production normalized water uses (123 l/kg to 19,600 l/kg).

Product Testing

Zirconium-Hafnium Inspection and Testing Wastewater. Wastewater is discharged from four product testing operations in this subcategory: a hydrotesting operation, a non-destructive testing operation, a dye penetrant testing operation, and an ultrasonic tube testing operation. Flow data were available for the hydrotesting operation and non-destructive testing operation. The BPT regulatory flow of 15.4 l/kg (3.70 gal/ton) is based on the production normalized discharge flow from the non-destructive testing operation. The hydrotesting operation flow was not included in the regulatory flow calculation because the Agency believes that the water used for hydrotesting can be recycled or reused in other water-demanding operations at the forming plant.

Degreasing

Zirconium-Hafnium Degreasing Spent Solvents. Three degreasing operations were reported in this subcategory. In one operation, the solvent is completely recycled with no discharge; spent solvent from two operations is contract hauled. Therefore, the BPT discharge allowance is zero.

Zirconium-Hafnium Degreasing Rinse. One plant discharges wastewater from a degreasing rinse operation. This is the only plant in the subcategory discharging wastewater from a degreasing operation. Samples of this wastewater were analyzed after proposal and high concentrations of volatile organic solvents

were detected. Some plants degrease formed zirconium without generating any wastewater by using solvents which need not be followed by a water rinse, while other plants degrease formed zirconium without solvents, by using alkaline (detergent) cleaning followed by a water rinse. Because the Agency believes this plant could achieve zero discharge by converting the water rinse into a second solvent cleaning step or could use a detergent cleaning instead of solvents, the BPT allowance for this solvent degreasing rinse stream is based on zero discharge.

Wet Air Pollution Control

Zirconium-Hafnium Wet Air Pollution Control Blowdown. Water is used in wet air pollution control devices on surface treatment, rolling, forging, and extrusion operations. A total of eight operations where wet air pollution control devices are used were identified. However, wastewater is reported to be discharged to surface water from only one of the eight operations. Therefore, since the majority of plants with this wastewater stream are achieving no discharge from this stream, there shall be no allowance for the discharge of wastewater pollutants.

Regulated Pollutants

The priority pollutants considered for regulation under BPT are listed in Section VI along with an explanation of why they were considered. The pollutants selected for regulation under BPT are total chromium, nickel, cyanide, fluoride, oil and grease, total suspended solids, and pH. The priority pollutants copper, lead, and zinc, and the nonconventional pollutants zirconium and hafnium, are not specifically regulated under BPT for the reasons explained in Section X. The basis for regulating oil and grease, total suspended solids, and pH was discussed earlier in this section. The basis for regulating total chromium, nickel, cyanide, ammonia, and fluoride is discussed below.

Total chromium is selected for regulation since it was found at treatable concentrations in 10 of 19 raw wastewater samples and five of nine raw wastewater streams in which it was analyzed. Treatable total chromium concentrations were found in tube reducing spent lubricant, surface treatment spent baths, surface treatment rinse, alkaline cleaning spent baths, and degreasing spent solvents. Waste streams such as surface treatment spent baths and surface treatment rinse may contain the hexavalent form of chromium. As previously discussed, preliminary chromium reduction is needed to reduce hexavalent chromium to the trivalent state since the hexavalent form is not removed by lime and settle technology. Therefore, regulation of total chromium is appropriate for this subcategory.

Nickel is selected for regulation since it was found at treatable concentrations in six of 19 raw wastewater samples and three of the nine raw wastewater streams in which it was analyzed. Nickel was found at treatable concentrations in tube reducing spent

lubricant, surface treatment spent baths, and degreasing spent solvents.

Cyanide is selected for regulation since it was found at treatable concentrations in surface treatment spent baths. Preliminary cyanide precipitation is needed to remove this pollutant from wastewater. Therefore, regulation of cyanide is appropriate for this subcategory.

Ammonia is selected for regulation because it was found at treatable concentrations in surface treatment baths and tube reducing spent lubricants. Preliminary ammonia steam stripping may be needed to remove ammonia from these wastewaters. Therefore, regulation of ammonia is appropriate for the zirconium-hafnium forming subcategory.

Fluoride is selected for regulation since it was found at treatable concentrations in five of 18 raw wastewater samples. Fluoride was found at treatable concentrations in surface treatment baths and rinses.

Treatment Train

The BPT model treatment train for the zirconium-hafnium forming subcategory consists of preliminary treatment when necessary, specifically chromium reduction, chemical emulsion breaking and oil skimming, and cyanide precipitation. The effluent from preliminary treatment is combined with other wastewater for common treatment by oil skimming and lime and settle. Waste streams potentially needing preliminary treatment are listed in Table IX-9. Figure IX-1 presents a schematic of the general BPT treatment train for the nonferrous metals forming category.

Effluent Limitations

The pollutant mass discharge limitations (milligrams of pollutant per off-kilogram of PNP) were calculated by multiplying the BPT regulatory flows summarized in Table IX-27 (l/kg) by the concentration achievable by the BPT model treatment system summarized in Table VII-21 (mg/l) for each pollutant parameter considered for regulation at BPT ($l/kg \times mg/l \times kkg/1,000 kg = mg/off-kg$). The results of this computation for all waste streams and regulated pollutants in the zirconium-hafnium forming subcategory are summarized in Table IX-28. Although no limitations have been established for zirconium and hafnium, Table IX-28 includes zirconium and hafnium mass discharge limitations attainable using the BPT model technology. These limitations are presented for the guidance of permit writers. The limitations table lists all the pollutants which were considered for regulation. Those specifically regulated are marked with an asterisk.

Costs and Benefits

In establishing BPT, EPA must consider the cost of treatment and control in relation to the effluent reduction benefits. BPT

costs and benefits are tabulated along with BAT costs and benefits in Section X. As shown in Table X-11 (page xxxx), the application of BPT to the total zirconium-hafnium forming subcategory will remove approximately 17,340 kg/yr (38,150 lbs/yr) of pollutants including 640 kg/yr (1,410 lbs/yr) of toxic metals. As shown in Table X-1 (page xxxx), the corresponding capital and annual costs (1982 dollars) for this removal are \$0.367 million and \$0.330 million per year, respectively. As shown in Table X-21 (page xxxx), the application of BPT to direct dischargers only will remove approximately 16,315 kg/yr (35,890 lbs/yr) of pollutants including 640 kg/yr (1,410 lbs/yr) of toxic metals. As shown in Table X-2 (page xxxx), the corresponding capital and annual costs (1982 dollars) for this removal are \$0.359 million and \$0.327 million per year, respectively. The Agency concludes that these pollutant removals justify the costs incurred by plants in this subcategory.

METAL POWDERS SUBCATEGORY

Production Operations and Discharge Flows

Production operations that generate process wastewater in the metal powders subcategory include metal powder production, tumbling, burnishing, cleaning, sawing, grinding, sizing, steam treatment, oil-resin impregnation, degreasing, hot pressing, and mixing. Water use practices, wastewater streams and wastewater discharge flows from these operations were discussed in Section V. This information provided the basis for development of the BPT regulatory flow allowances summarized in Table IX-29. The following paragraphs discuss the basis for the BPT flow allowances for each waste stream.

Metal Powder Production

Metal powder production operations were reported by approximately 70 plants in this subcategory. The following information is available from these plants:

Number of plants and operations with wet atomization wastewater:
5 plants, 6 operations

Number of plants and operations with wet air pollution control devices: 2.

Metal Powder Production Wet Atomization Wastewater. No recycle was reported for any of the six operations. From an examination of the available data, it is not apparent that there is any significant difference in water use and discharge among the different metals in this subcategory. Therefore, the BPT discharge allowance is the average production normalized discharge flow from the six operations, 5,040 l/kg (1,210 gal/ton).

Tumbling, Burnishing or Cleaning

Metal Powders Tumbling, Burnishing or Cleaning Wastewater. Twenty-nine plants reported information on 40 tumbling, burnish-

ing, and other physical-chemical cleaning operations associated with powder metallurgy parts production. Water use data were available for 25 operations. The BPT regulatory flow of 4,400 l/kg (1,050 gal/ton) is based on the average production normalized water use for the 25 operations.

Sawing or Grinding

Metal Powders Sawing or Grinding Spent Neat Oils. A neat oil lubricant is used in one operation. Spent neat oils from this operation are contract hauled to treatment and disposal off-site. It is better to handle neat oils in this manner rather than combine them with wastewater streams only to remove them later using oil-water separation treatment. Therefore, the BPT discharge allowance is zero.

Metal Powders Sawing or Grinding Spent Emulsions. Emulsion lubricants are used in seven operations. No emulsions are discharged from one operation; emulsions are periodically discharged from five operations; emulsions are discharged on a once-through basis from one operation. The production normalized discharge flow from the once-through operation is over five times higher than the discharge values from the other operations. This value was not included in the regulatory flow calculation because it does not represent the current typical discharge practice for this subcategory. The BPT regulatory flow of 18.1 l/kg (4.33 gal/ton) is based on the average production normalized discharge flow of the five periodic discharge operations.

Metal Powders Sawing or Grinding Contact Cooling Water. Contact cooling water is used in four operations. Flow data were available for one of these operations. The cooling water is discharged on a once-through basis from this operation. The current water use at the one plant reporting flow data is excessive compared to current water use for this operation in other subcategories. The BPT regulatory flow of 1,620 l/kg (389 gal/ton) is based on 99 percent recycle of the water use for this one operation. This is comparable to the allowance for this operation in other subcategories.

Sizing

Metal Powders Sizing Spent Neat Oils. Neat oil lubricants are used in two sizing operations. The neat oils are completely recycled with no discharge in either operation. Should the neat oil from either operation ever need to be disposed, it would be better to directly remove the oil by contract hauling rather than to commingle the oil with wastewater streams and then remove it later. Therefore, the BPT discharge allowance is zero.

Metal Powders Sizing Spent Emulsions. An emulsion lubricant is used in one sizing operation. Since spent emulsions are often treated on-site and the water fraction discharged by plants in this category and other categories, EPA is allowing a discharge for this waste stream. The BPT discharge allowance of 14.6 l/kg

(3.50 gal/ton) is based on the production normalized water use for this operation.

Steam Treatment

Metal Powders Steam Treatment Wet Air Pollution Control Blowdown. One plant operates a wet scrubber to control air pollution from its steam treatment process. No recycle of the scrubber water is practiced. The BPT discharge allowance of 792 l/kg (190 gal/ton) is based on the production normalized water use for the one operation.

Oil-Resin Impregnation

Metal Powders Oil-Resin Impregnation Spent Neat Oils. Seven plants reported using neat oils in oil-resin impregnation processes. Neat oils are completely recycled with no discharge in two operations; spent neat oils from three operations are contract hauled; no data are available for the other two operations. It is better to remove neat oils directly by contract hauling rather than to commingle them with wastewater streams and then remove them later using oil-water separation treatment. Therefore, this waste stream should not be discharged.

Degreasing

Metal Powders Degreasing Spent Solvents. Only a small number of surveyed plants with solvent degreasing operations have process wastewater streams associated with the operation. Because most plants practice solvent degreasing without wastewater discharge, the Agency believes zero discharge of wastewater is an appropriate discharge limitation.

Hot Pressing

Metal Powders Hot Pressing Contact Cooling Water. One plant reported using contact cooling water in a hot pressing operation. None of the cooling water used in this operation is recycled. The BPT regulatory flow of 8,800 l/kg (2,110 gal/ton) is based on the production normalized water use for the one operation.

Mixing

Metal Powders Mixing Wet Air Pollution Control Blowdown. One plant reported using a wet scrubber to control air pollution from a mixing operation. Ninety percent of the scrubber water is recycled. The BPT regulatory flow of 7,900 l/kg (1,890 gal/ton) is based on the production normalized discharge flow from the scrubber.

Deleted Waste Streams

Metal Powder Production Milling Wastewater. Following proposal, the Agency received additional data and conducted a review of all available data concerning wastewater discharges in this subcate-

gory. This review led to a reinterpretation of some data reported prior to proposal. As a result, the Metal Powder Production Milling wastewater stream included in the proposed regulation for this subcategory has been deleted from the final regulation. This waste stream was improperly classified at proposal. Since the plant believed to have this wastewater at proposal actually mills fabricated parts, not powder, its reported production normalized flow was included in the calculation of the tumbling, burnishing or cleaning wastewater discharge allowance.

Metal Powder Production Wet Air Pollution Control Blowdown. Prior to proposal, two plants reported the use of wet air pollution control devices associated with metal powders production. One plant reported complete recycle of scrubber water; the other reported that 85 percent of the scrubber water is recycled. Following proposal, the Agency received additional data concerning wastewater discharges in this subcategory. These data included the fact that the discharging scrubber is no longer operated. Therefore, the Metal Powder Production Wet Air Pollution Control Blowdown waste stream included in the proposed regulation for this subcategory has been deleted from the final regulation.

Regulated Pollutants

The priority pollutants considered for regulation under BPT are listed in Section VI along with an explanation of why they were considered. The pollutants selected for regulation under BPT are copper, lead, cyanide, oil and grease, total suspended solids and pH. The priority pollutants chromium, nickel, and zinc, and the nonconventional pollutants iron and aluminum are not specifically regulated under BPT for the reasons explained in Section X. The basis for regulating oil and grease, total suspended solids, and pH was discussed earlier in this section. The basis for regulating copper, lead, and cyanide is discussed below.

Copper is regulated since it is one of the metals being processed in this subcategory and it was found at treatable concentrations in 10 of 18 raw wastewater samples and three of the four raw wastewater streams in which it was analyzed. Copper was present at treatable concentrations in metal powder production wet atomization wastewater, tumbling, burnishing or cleaning wastewater, and sawing or grinding spent emulsions.

Lead is selected for regulation since it was found at treatable concentrations in eight of 18 samples and three of the four raw wastewater streams in which it was analyzed. Lead was found at treatable concentrations in the same raw waste streams listed in the previous paragraph for copper.

Cyanide is selected for regulation since it was present in treatable concentrations in eight of 17 raw wastewater samples and three of the four raw wastewater streams in which it was analyzed. Treatable concentrations of cyanide were found in

tumbling, burnishing or cleaning wastewater, sawing or grinding spent emulsions, and steam treatment wet air pollution control blowdown. Preliminary cyanide precipitation is needed to remove cyanide from these wastewater streams. Therefore, regulation of cyanide is appropriate for this subcategory.

Treatment Train

The BPT model treatment train for the metal powders subcategory consists of preliminary treatment when necessary, specifically chemical emulsion breaking and oil skimming and cyanide precipitation. The effluent from preliminary treatment is combined with other wastewater for common treatment by oil skimming and lime and settle. Waste streams potentially needing preliminary treatment are listed in Table IX-10. Figure IX-1 presents a schematic of the general BPT treatment train for the nonferrous metals forming category.

Effluent Limitations

The pollutant mass discharge limitations (milligrams of pollutant per off-kilogram of PNP) were calculated by multiplying the BPT regulatory flows summarized in Table IX-29 (l/kkg) by the concentration achievable by the BPT model treatment system summarized in Table VII-21 (mg/l) for each pollutant parameter considered for regulation at BPT ($l/kkg \times mg/l \times kkg/1,000 \text{ kg} = mg/off\text{-kg}$). The results of this computation for all waste streams and regulated pollutants in the metal powders subcategory are summarized in Table IX-30. Although no limitations have been established for iron and aluminum, Table IX-30 includes mass discharge limitations for these pollutants attainable using the BPT model technology. These limitations are presented for the guidance of permit writers. The limitations table lists all the pollutants which were considered for regulation. Those specifically regulated are marked with an asterisk.

Costs and Benefits

In establishing BPT, EPA considered the cost of treatment and control and the pollutant reduction benefits to evaluate economic achievability. As shown in Table X-12 (page xxxx), the application of BPT to the total metal powders subcategory will remove approximately 57,570 kg/yr (126,650 lbs/yr) of pollutants including 1,085 kg/yr (2,390 lbs/yr) of toxic pollutants. As shown in Table X-22 (page xxxx), the application of BPT to direct dischargers only will remove approximately 4,105 kg/yr (9,030 lbs/yr) of pollutants including 128 kg/yr (282 lbs/yr) of toxic pollutants. Since there are only three direct discharge plants in this subcategory, total subcategory capital and annual costs will not be reported in this document in order to protect confidentiality claims. The Agency concludes that the pollutant removals justify the costs incurred by plants in this subcategory.

APPLICATION OF REGULATION IN PERMITS

The purpose of these limitations (and standards) is to form a uniform basis for regulating wastewater effluent from the nonferrous metals forming category. For direct dischargers, this is accomplished through NPDES permits. Since the nonferrous metals forming category is regulated on an individual waste stream "building-block" approach, three examples of applying these limitations to determine the allowable discharge from nonferrous metals forming facilities are given below.

Example 1

Plant X forms a refractory metal strip by a rolling operation which uses an emulsion as a lubricant. The plant produces 20 kkg (44,000 lbs) of final product strip per day. In the process, a stock billet is heated and put through a reversing rolling mill for five passes, then annealed (dry annealing), brought back to the rolling mill for three more passes, annealed again, rolled for four more passes, and annealed for a final time to produce the product. Table IX-31 illustrates the calculation of the allowable BPT discharge for nickel, one of the pollutants regulated in this subcategory. The allowable discharge for the other regulated pollutants would be calculated in the same way.

This example illustrates the calculation of an allowable pollutant mass discharge using "off-kilograms." The term "off-kilogram" means the mass of metal or metal alloy removed from a forming operation at the end of a process cycle for transfer to a different machine or process. A reversing mill allows the metal to pass between the rollers several times without having to be removed from the mill. Therefore, on a multiple pass roll, the mass of metal rolled is considered to have been processed only once; the off-mass equals the mass. In this example, since the metal is removed from the reversing mill for annealing and then returned, the off-mass of rolling equals the mass of metal times the number of times it is returned to the process. Therefore, for this plant, the off-kilograms to produce 20 kkg of final product is 60 off-kkg. This is the daily production used in the calculations presented in Table IX-31.

Example 2

Plant Y forms lead bullets by an extrusion and swaging process and casts lead shot. The plant operates 250 days per year with a total annual production of 250,000 kg (551,000 lbs) of shot and 1,000,000 kg (2,205,000 lbs) of bullets. Shot is produced by casting. Bullets are produced by casting lead into ingots (stationary casting), extrusion followed by a spray quench at the press, and swaging. Approximately 5 percent of the lead is lost to scrap following extrusion. The bullets are washed and rinsed before being assembled into cartridges. Table IX-32 illustrates the calculation of the allowable BPT discharge of total suspended solids (TSS).

The daily shot casting production is 250,000 kg/yr divided by 250 days/yr or 1,000 kg/day. The number of kg of shot produced is equal to the number of off-kg formed. This production is multiplied by the shot casting limitation (mg/off-kg) to get the daily discharge limit for shot casting at Plant Y. The daily amount of lead cast and extruded is 1,050,000 kg/yr divided by 250 days/yr or 4,200 kg/day. This production is multiplied by the limitations (mg/off-kg) for extrusion press or solution heat treatment contact cooling water and extrusion press hydraulic fluid leakage to get the first part of the daily discharge limits for bullet making. The daily bullet production is 1,000,000 kg/yr divided by 250 days/yr or 4,000 kg/day. This production is multiplied by the limitations (mg/off-kg) for swaging spent emulsions, alkaline cleaning spent baths, and alkaline cleaning rinse to get the second part of the daily discharge limits for bullet making. The sum of the daily limits for the individual operations becomes the plant limit.

Example 3

Plant Z forms nickel and titanium alloys. This plant forges 125 kkg (275,000 lbs) of nickel and 25 kkg (55,000 lbs) of titanium per year (250 days). Eighty percent of the nickel and 10 percent of the titanium are pickled, then rinsed with a spray. The plant also contact cools forgings with water following forging and has a wet air pollution control scrubber to control the fumes from the pickling bath. This example demonstrates the application of the limitations for nickel which is a regulated pollutant in the nickel forming subcategory and for cyanide a regulated pollutant in the titanium forming subcategory to the combined discharge of nickel forming process wastewater and titanium forming process wastewater. Table IX-33 illustrates the calculation of the BPT discharge allowance for nickel. Although nickel was not specifically regulated in the titanium forming subcategory, it is present in treatable concentrations in titanium forming wastewater. The Agency chose not to specifically regulate nickel in this subcategory because it should be adequately controlled by the other regulated pollutants. Since nickel is present in the titanium forming wastewater, Plant Z will need an allowance for nickel from this source to comply with the nickel discharge allowance. Therefore, the mass allowance for nickel from the titanium forming wastewater is added to the mass allowance from nickel-cobalt forming. The mass limitations for nickel can be obtained from Tables IX-16 and IX-22 which provide the limitations for regulated pollutants and other pollutants considered for but not specifically regulated.

The calculation of the mass allowance for the pollutant cyanide is illustrated in Table IX-34. Cyanide is regulated in the titanium forming subcategory, but not in the nickel-cobalt forming subcategory. Cyanide was not found in significant quantities in any nickel-cobalt process wastewater, and was not considered for regulation in the nickel-cobalt subcategory. Since the nickel-forming process wastewater from Plant Z would not be expected to contribute any cyanide to the mass loading in

the effluent, it is not appropriate to add a mass allowance for cyanide from the nickel forming wastewater to the mass allowance for cyanide from the titanium forming wastewater.

Table IX-1
 POTENTIAL PRELIMINARY TREATMENT REQUIREMENTS
 LEAD-TIN-BISMUTH FORMING SUBCATEGORY

Operation	Waste Stream	Possible Required Preliminary Treatments
Rolling	Spent emulsions Spent soap solutions	Chemical emulsion breaking None
Drawing	Spent emulsions Spent soap solutions	Chemical emulsion breaking None
Extrusion	Press or solution heat treatment contact cooling water Press hydraulic fluid leakage	None Chemical emulsion breaking
Swaging	Spent emulsions	Chemical emulsion breaking
Casting		
Continuous Strip Casting	Contact cooling water	None
Semi-Continuous Ingot Casting	Contact cooling water	None
Shot Casting	Contact cooling water	None
Shot Forming	Wet air pollution control blowdown	None
Alkaline Cleaning	Spent baths Rinsewater	None None

1626

Table IX-2

POTENTIAL PRELIMINARY TREATMENT REQUIREMENTS
MAGNESIUM FORMING SUBCATEGORY

Operation	Waste Stream	Possible Required Preliminary Treatments
Rolling	Spent emulsions	Chemical emulsion breaking
Forging	Contact cooling water Equipment cleaning wastewater	None None
Casting		
Direct Chill Casting	Contact cooling water	None
Surface Treatment	Spent baths Rinsewater	Chromium reduction, ammonia steam stripping Chromium reduction, ammonia steam stripping
Sawing or Grinding	Spent emulsions	Chemical emulsion breaking
Wet Air Pollution Control	Blowdown	Chromium reduction

Table IX-3

POTENTIAL PRELIMINARY TREATMENT REQUIREMENTS
NICKEL-COBALT FORMING SUBCATEGORY

Operation	Waste Stream	Possible Required Preliminary Treatments
Rolling	Spent emulsions Contact cooling water	Chemical emulsion breaking None
Drawing	Spent emulsions	Chemical emulsion breaking
Extrusion	Press or solution heat treatment contact cooling water	None
	Press hydraulic fluid leakage	Chemical emulsion breaking
Forging	Contact cooling water	None
	Equipment cleaning wastewater	None
	Press hydraulic fluid leakage	Chemical emulsion breaking
Metal Powder Production	Atomization wastewater	None
Casting		
Stationary	Contact cooling water	None
Surface Treatment	Spent baths	Chromium reduction
	Rinsewater	Chromium reduction

1628

Table IX-3 (Continued)

POTENTIAL PRELIMINARY TREATMENT REQUIREMENTS
NICKEL-COBALT FORMING SUBCATEGORY

Operation	Waste Stream	Possible Required Preliminary Treatments
Ammonia	Rinse	None
Alkaline Cleaning	Spent baths Rinsewater	Chromium reduction None
Molten Salt	Rinsewater	Chromium reduction
Sawing or Grinding	Spent emulsions Rinsewater	Chemical emulsion breaking None
Steam Cleaning	Condensate	None
Dye Penetrant Testing	Wastewater	None
Miscellaneous Wastewater Sources	Various	None
Wet Air Pollution Control	Blowdown	Chromium reduction
Electrocoating	Rinsewater	None

1629

Table IX-4

POTENTIAL PRELIMINARY TREATMENT REQUIREMENTS
 PRECIOUS METALS FORMING SUBCATEGORY

Operation	Waste Stream	Possible Required Preliminary Treatments
Rolling	Spent emulsions	Chemical emulsion breaking
Drawing	Spent emulsions Spent soap solutions	Chemical emulsion breaking None
Metal Powder Production	Atomization wastewater	None
Casting		
Direct Chill Casting	Contact cooling water	None
Shot Casting	Contact cooling water	None
Semi-Continuous and Continuous Casting	Contact cooling water	None
Heat Treatment	Contact cooling water	None
Surface Treatment	Spent baths Rinsewater	None None
Alkaline Cleaning	Spent baths Rinsewater Prebonding wastewater	None None None
Tumbling or Burnishing	Wastewater	Cyanide precipitation
Sawing or Grinding	Spent emulsions	Chemical emulsion breaking
Pressure Bonding	Contact cooling water	None

1630

Table IX-5

POTENTIAL PRELIMINARY TREATMENT REQUIREMENTS
REFRACTORY METALS FORMING SUBCATEGORY

Operation	Waste Stream	Possible Required Preliminary Treatments
Rolling	Spent emulsions	Chemical emulsion breaking
Extrusion	Press hydraulic fluid leakage	Chemical emulsion breaking
Forging	Contact cooling water	None
Metal Powder	Wastewater	None
Surface Treatment	Spent baths Rinsewater	Chromium reduction Chromium reduction
Alkaline Cleaning	Spent baths Rinsewater	None None
Molten Salt	Rinsewater	Chromium reduction
Tumbling or Burnishing	Wastewater	Chromium reduction
Sawing or Grinding	Spent emulsions Contact cooling water Rinsewater	Chemical emulsion breaking None None
Dye Penetrant Testing	Wastewater	-----
Equipment Cleaning	Wastewater	None

1631

Table IX-5 (Continued)

POTENTIAL PRELIMINARY TREATMENT REQUIREMENTS
REFRACTORY METALS FORMING SUBCATEGORY

Operation	Waste Stream	Possible Required Preliminary Treatments
Miscellaneous Wastewater Sources	Various	None
Wet Air Pollution Control	Blowdown	Chromium reduction

1632

Table IX-6

POTENTIAL PRELIMINARY TREATMENT REQUIREMENTS
TITANIUM FORMING SUBCATEGORY

Operation	Waste Stream	Possible Required Preliminary Treatments
Rolling	Contact cooling water	None
Extrusion	Spent emulsions Press hydraulic fluid leakage	Chemical emulsion breaking Chemical emulsion breaking
Forging	Contact cooling water Equipment cleaning wastewater press hydraulic fluid leakage	None None Chemical emulsion breaking
Surface Treatment	Spent baths Rinsewater	Ammonia steam stripping, chromium reduction Ammonia steam stripping, chromium reduction
Alkaline Cleaning	Spent baths Rinsewater	None None
Molten Salt	Rinsewater	Chromium reduction
Tumbling	Washwater	Cyanide precipitation
Sawing or Grinding	Spent emulsions and synthetic coolants Contact cooling water	Chemical emulsion breaking None

1633

Table IX-6 (Continued)

POTENTIAL PRELIMINARY TREATMENT REQUIREMENTS
TITANIUM FORMING SUBCATEGORY

Operation	Waste Stream	Possible Required Preliminary Treatments
Dye Penetrant Testing	Wastewater	-----
Miscellaneous Wastewater Sources	Various	None
Wet Air Pollution Control	Blowdown	Chromium reduction

1634

Table IX-7

POTENTIAL PRELIMINARY TREATMENT REQUIREMENTS
URANIUM FORMING SUBCATEGORY

Operation	Waste Stream	Possible Required Preliminary Treatments
Extrusion	Tool contact cooling water	None
Heat Treatment	Contact cooling water	None
Surface Treatment	Spent baths Rinsewater	None None
Sawing or Grinding	Spent emulsions Contact cooling water Rinsewater	Chemical emulsion breaking None None
Area Cleaning	Washwater	None
Wet Air Pollution Control	Blowdown	Chromium Reduction
Drum Washwater	Wastewater	None
Laundry Washwater	Wastewater	None

1635

Table IX-8

POTENTIAL PRELIMINARY TREATMENT REQUIREMENTS
ZINC FORMING SUBCATEGORY

Operation	Waste Stream	Possible Required Preliminary Treatments
Rolling	Spent emulsions Contact cooling water	Chemical emulsion breaking None
Drawing	Spent emulsions	Chemical emulsion breaking, cyanide precipitation
Casting		
Direct Chill Casting	Contact cooling water	None
Annealing and Solution Heat Treatment	Contact cooling water	None
Surface Treatment	Spent baths Rinsewater	Chromium reduction Chromium reduction
Alkaline Cleaning	Spent baths Rinsewater	Cyanide precipitation Cyanide precipitation
Sawing or Grinding	Spent emulsions	Chemical emulsion breaking
Electrocoating	Rinsewater	None

Table IX-9

POTENTIAL PRELIMINARY TREATMENT REQUIREMENTS
ZIRCONIUM-HAFNIUM FORMING SUBCATEGORY

Operation	Waste Stream	Possible Required Preliminary Treatments
Extrusion	Press hydraulic fluid leakage	Chemical emulsion breaking
Heat Treatment	Contact cooling water	None
Surface Treatment	Spent baths	Ammonia steam stripping, cyanide precipitation
	Rinsewater	Ammonia steam stripping, cyanide precipitation
Alkaline Cleaning	Spent baths	None
	Rinsewater	None
Molten Salt	Rinsewater	Chromium reduction
Sawing or Grinding	Spent emulsions	Chemical emulsion breaking
	Contact cooling water	None
	Rinsewater	None
Inspection and Testing	Wastewater	None

1637

Table IX-10

POTENTIAL PRELIMINARY TREATMENT REQUIREMENTS
METAL POWDERS SUBCATEGORY

Operation	Waste Stream	Possible Required Preliminary Treatments
Metal Powder Production	Atomization wastewater	None
Tumbling, Burnishing, and Cleaning	Wastewater	Cyanide precipitation
Sawing or Grinding	Spent emulsions Contact cooling water	Chemical emulsion breaking None
Sizing	Spent emulsions	Chemical emulsion breaking
Steam Treatment Wet Air Pollution Control	Blowdown	None
Hot Pressing	Contact cooling water	None
Mixing Wet Air Pollution Control	Blowdown	None

1638

Table IX-11

BPT REGULATORY FLOWS FOR
 PRODUCTION OPERATIONS - LEAD-TIN-BISMUTH FORMING SUBCATEGORY

Operation	Waste Stream	Normalized BPT Discharge		Production Normalizing Parameter
		l/kgg	gal/ton	
Rolling	Spent emulsions	23.4	5.60	Mass of lead-tin-bismuth rolled with emulsions
	Spent soap solutions	43.0	10.3	Mass of lead-tin-bismuth rolled with soap solutions
Drawing	Spent neat oils	0	0	
	Spent emulsions	26.3	6.30	Mass of lead-tin-bismuth drawn with emulsions
	Spent soap solutions	7.46	1.79	Mass of lead-tin-bismuth drawn with soap solutions
Extrusion	Press or solution heat treatment contact cooling water	1,440	346	Mass of lead-tin-bismuth heat treated and subsequently cooled with water
	Press hydraulic fluid leakage	55.0	13.2	Mass of lead-tin-bismuth extruded
Swaging	Spent emulsions	1.77	0.424	Mass of lead-tin-bismuth swaged with emulsions
Casting				
Continuous Strip Casting	Contact cooling water	1.00	0.240	Mass of lead-tin-bismuth cast by the continuous strip method
Semi-Continuous Ingot Casting	Contact cooling water	29.4	7.04	Mass of lead-tin-bismuth ingot cast by the semi-continuous method
Shot Casting	Contact cooling water	37.3	8.95	Mass of lead-tin-bismuth shot

Table IX-11 (Continued)
 BPT REGULATORY FLOWS FOR
 PRODUCTION OPERATIONS - LEAD-TIN-BISMUTH FORMING SUBCATEGORY

Operation	Waste Stream	Normalized BPT Discharge		Production Normalizing Parameter
		l/kg	gal/ton	
Shot-forming	Wet air pollution control blowdown	588	141	Mass of lead-tin-bismuth shot formed
Alkaline Cleaning	Spent baths	120	28.7	Mass of lead-tin-bismuth alkaline cleaned
	Rinsewater	2,360	565	Mass of lead-tin-bismuth alkaline cleaned
Degreasing	Spent solvents	0	0	

1640

Table IX-12

LEAD-TIN-BISMUTH FORMING SUBCATEGORY
BPT EFFLUENT LIMITATIONS

BPT
Lead-Tin-Bismuth Forming
Rolling Spent Emulsions

Pollutant or pollutant property	Maximum for any one day	Maximum for monthly average
mg/off-kg (lb/million off-lbs) of lead-tin-bismuth rolled with emulsions		
*Antimony	.067	.030
*Lead	.010	.005
*Oil and Grease	.468	.281
*TSS	.960	.457
*pH	Within the range of 7.5 to 10.0 at all times	

BPT
Lead-Tin-Bismuth Forming
Rolling Spent Soap Solutions

Pollutant or pollutant property	Maximum for any one day	Maximum for monthly average
mg/off-kg (lb/million off-lbs) of lead-tin-bismuth rolled with soap solutions		
*Antimony	.124	.055
*Lead	.018	.009
*Oil and Grease	.860	.516
*TSS	1.770	.839
*pH	Within the range of 7.5 to 10.0 at all times	

BPT
Lead-Tin-Bismuth Forming
Drawing Spent Neat Oils

There shall be no discharge of process wastewater
pollutants.

Table IX-12 (Continued)

LEAD-TIN-BISMUTH FORMING SUBCATEGORY
BPT EFFLUENT LIMITATIONSBPT
Lead-Tin-Bismuth Forming
Drawing Spent Emulsions

Pollutant or pollutant property	Maximum for any one day	Maximum for monthly average
mg/off-kg (lb/million off-lbs) of lead-tin-bismuth drawn with emulsions		
*Antimony	.076	.034
*Lead	.011	.005
*Oil and Grease	.526	.316
*TSS	1.080	.513
*pH	Within the range of 7.5 to 10.0 at all times	

BPT
Lead-Tin-Bismuth Forming
Drawing Spent Soap Solutions

Pollutant or pollutant property	Maximum for any one day	Maximum for monthly average
mg/off-kg (lb/million off-lbs) of lead-tin-bismuth drawn with soap solutions		
*Antimony	.021	.010
*Lead	.003	.001
*Oil and Grease	.149	.090
*TSS	.306	.146
*pH	Within the range of 7.5 to 10.0 at all times	

Table IX-12 (Continued)

LEAD-TIN-BISMUTH FORMING SUBCATEGORY
BPT EFFLUENT LIMITATIONS

BPT
Lead-Tin-Bismuth Forming
Extrusion Press or Solution Heat Treatment CCW

Pollutant or pollutant property	Maximum for any one day	Maximum for monthly average
mg/off-kg (lb/million off-lbs) of lead-tin-bismuth heat treated		
*Antimony	4.130	1.850
*Lead	.605	.288
*Oil and Grease	28.800	17.300
*TSS	59.100	28.100
*pH	Within the range of 7.5 to 10.0 at all times	

BPT
Lead-Tin-Bismuth Forming
Extrusion Press Hydraulic Fluid Leakage

Pollutant or pollutant property	Maximum for any one day	Maximum for monthly average
mg/off-kg (lb/million off-lbs) of lead-tin-bismuth extruded		
*Antimony	.158	.070
*Lead	.023	.011
*Oil and Grease	1.100	.660
*TSS	2.260	1.070
*pH	Within the range of 7.5 to 10.0 at all times	

Table IX-12 (Continued)

LEAD-TIN-BISMUTH FORMING SUBCATEGORY
BPT EFFLUENT LIMITATIONS

BPT
Lead-Tin-Bismuth Forming
Swaging Spent Emulsions

Pollutant or pollutant property	Maximum for any one day	Maximum for monthly average
mg/off-kg (lb/million off-lbs) of lead-tin-bismuth swaged with emulsions		
*Antimony	.0051	.0023
*Lead	.0008	.0004
*Oil and Grease	.0354	.0213
*TSS	.0726	.0345
*pH	Within the range of 7.5 to 10.0 at all times	

BPT
Lead-Tin-Bismuth Forming
Continuous Strip Casting Contact Cooling Water

Pollutant or pollutant property	Maximum for any one day	Maximum for monthly average
mg/off-kg (lb/million off-lbs) of lead-tin-bismuth cast by the continuous strip method		
*Antimony	.0029	.0013
*Lead	.0004	.0002
*Oil and Grease	.0200	.0120
*TSS	.0410	.0195
*pH	Within the range of 7.5 to 10.0 at all times	

Table IX-12 (Continued)

LEAD-TIN-BISMUTH FORMING SUBCATEGORY
BPT EFFLUENT LIMITATIONS

BPT

Lead-Tin-Bismuth Forming

Semi-Continuous Ingot Casting Contact Cooling Water

Pollutant or pollutant property	Maximum for any one day	Maximum for monthly average
mg/off-kg (lb/million off-lbs) of lead-tin-bismuth ingot cast by the semi-continuous method		
*Antimony	.084	.038
*Lead	.012	.006
*Oil and Grease	.588	.353
*TSS	1.210	.574
*pH	Within the range of 7.5 to 10.0 at all times	

BPT

Lead-Tin-Bismuth Forming

Shot Casting Contact Cooling Water

Pollutant or pollutant property	Maximum for any one day	Maximum for monthly average
mg/off-kg (lb/million off-lbs) of lead-tin-bismuth shot cast		
*Antimony	.107	.048
*Lead	.016	.007
*Oil and Grease	.746	.448
*TSS	1.530	.728
*pH	Within the range of 7.5 to 10.0 at all times	

Table IX-12 (Continued)

LEAD-TIN-BISMUTH FORMING SUBCATEGORY
BPT EFFLUENT LIMITATIONS

BPT

Lead-Tin-Bismuth Forming

Shot-Forming Wet Air Pollution Control Blowdown

Pollutant or pollutant property	Maximum for any one day	Maximum for monthly average
mg/off-kg (lb/million off-lbs) of lead-tin-bismuth shot formed		
*Antimony	1.690	.753
*Lead	.247	.118
*Oil and Grease	11.800	7.060
*TSS	24.100	11.500
*pH	Within the range of 7.5 to 10.0 at all times	

BPT

Lead-Tin-Bismuth Forming

Alkaline Cleaning Spent Baths

Pollutant or pollutant property	Maximum for any one day	Maximum for monthly average
mg/off-kg (lb/million off-lbs) of lead-tin-bismuth alkaline cleaned		
*Antimony	.345	.154
*Lead	.050	.024
*Oil and Grease	2.400	1.440
*TSS	4.920	2.340
*pH	Within the range of 7.5 to 10.0 at all times	

Table IX-12 (Continued)

LEAD-TIN-BISMUTH FORMING SUBCATEGORY
BPT EFFLUENT LIMITATIONS

BPT
Lead-Tin-Bismuth Forming
Alkaline Cleaning Rinse

Pollutant or pollutant property	Maximum for any one day	Maximum for monthly average
mg/off-kg (lb/million off-lbs) of lead-tin-bismuth alkaline cleaned		
*Antimony	6.780	3.020
*Lead	.991	.472
*Oil and Grease	47.200	28.300
*TSS	96.800	46.000
*pH	Within the range of 7.5 to 10.0 at all times	

BPT
Lead-Tin-Bismuth Forming
Degreasing Spent Solvents

There shall be no discharge of process wastewater
pollutants.

Table-IX-13
 BPT REGULATORY FLOWS FOR
 PRODUCTION OPERATIONS - MAGNESIUM FORMING SUBCATEGORY

Operation	Waste Stream	Normalized BPT Discharge		Production Normalizing Parameter
		l/kg	gal/ton	
Rolling	Spent emulsions	74.6	17.9	Mass of magnesium rolled with emulsions
Forging	Spent lubricants	0	0	
	Contact cooling water	2,890	693	Mass of forged magnesium cooled with water
	Equipment cleaning wastewater	39.9	9.59	Mass of magnesium forged on equipment requiring cleaning with water
Direct Chill Casting	Contact cooling water	3,950	947	Mass of magnesium cast with direct chill methods
Surface Treatment	Spent baths	466	112	Mass of magnesium surface treated
	Rinsewater	18,900	4,520	Mass of magnesium surface treated
Sawing or Grinding	Spent emulsions	19.5	4.68	Mass of magnesium sawed or ground
Degreasing	Spent solvents	0	0	
Wet Air Pollution Control	Blowdown	619	148	Mass of magnesium sanded and repaired or forged

1648

Table IX-14

MAGNESIUM FORMING SUBCATEGORY
BPT EFFLUENT LIMITATIONS

BPT
Magnesium Forming
Rolling Spent Emulsions

Pollutant or pollutant property	Maximum for any one day	Maximum for monthly average
mg/off-kg (lb/million off-lbs) of magnesium rolled with emulsions		
*Chromium	.033	.013
*Zinc	.109	.046
*Ammonia	9.950	4.370
*Fluoride	4.440	1.970
Magnesium	.007	---
*Oil and Grease	1.490	.895
*TSS	3.060	1.460
*pH	Within the range of 7.5 to 10.0 at all times	

BPT
Magnesium Forming
Forging Spent Lubricants

There could be no discharge of process wastewater
pollutants.

BPT
Magnesium Forming
Forging Contact Cooling Water

Pollutant or pollutant property	Maximum for any one day	Maximum for monthly average
mg/off-kg (lb/million off-lbs) of forged magnesium cooled with water		
*Chromium	1.270	.520
*Zinc	4.220	1.760
*Ammonia	385.000	170.000
*Fluoride	172.000	76.300
Magnesium	.289	---
*Oil and Grease	57.800	34.700
*TSS	119.000	56.400
*pH	Within the range of 7.5 to 10.0 at all times	

Table IX-14 (Continued)

MAGNESIUM FORMING SUBCATEGORY
BPT EFFLUENT LIMITATIONS

BPT
Magnesium Forming
Forging Equipment Cleaning Wastewater

Pollutant or pollutant property	Maximum for any one day	Maximum for monthly average
mg/off-kg (lb/million off-lbs) of magnesium forged		
*Chromium	.0176	.0072
*Zinc	.0583	.0244
*Ammonia	5.3200	2.3400
*Fluoride	2.3800	1.0600
Magnesium	.0040	---
*Oil and Grease	.7980	.4790
*TSS	1.6400	.7780
*pH	Within the range of 7.5 to 10.0 at all times	

BPT
Magnesium Forming
Direct Chill Casting Contact Cooling Water

Pollutant or pollutant property	Maximum for any one day	Maximum for monthly average
mg/off-kg (lb/million off-lbs) of magnesium cast with direct chill methods		
*Chromium	1.740	.711
*Zinc	5.770	2.410
*Ammonia	527.000	232.000
*Fluoride	235.000	104.000
Magnesium	.395	---
*Oil and Grease	79.000	47.400
*TSS	162.000	77.000
*pH	Within the range of 7.5 to 10.0 at all times	

Table IX-14 (Continued)

MAGNESIUM FORMING SUBCATEGORY
BPT EFFLUENT LIMITATIONS

BPT
Magnesium Forming
Surface Treatment Spent Baths

Pollutant or pollutant property	Maximum for any one day	Maximum for monthly average
mg/off-kg (lb/million off-lbs) of magnesium surface treated		
*Chromium	.205	.084
*Zinc	.681	.284
*Ammonia	62.100	27.300
*Fluoride	27.700	12.300
Magnesium	.047	---
*Oil and Grease	9.320	5.590
*TSS	19.100	9.090
*pH	Within the range of 7.5 to 10.0 at all times	

BPT
Magnesium Forming
Surface Treatment Rinse

Pollutant or pollutant property	Maximum for any one day	Maximum for monthly average
mg/off-kg (lb/million off-lbs) of magnesium surface treated		
*Chromium	8.320	3.400
*Zinc	27.600	11.500
*Ammonia	2,520.000	1,110.000
*Fluoride	1,130.000	499.000
Magnesium	1.890	---
*Oil and Grease	378.000	227.000
*TSS	775.000	369.000
*pH	Within the range of 7.5 to 10.0 at all times	

Table IX-14 (Continued)

MAGNESIUM FORMING SUBCATEGORY
BPT EFFLUENT LIMITATIONSBPT
Magnesium Forming
Sawing or Grinding Spent Emulsions

Pollutant or pollutant property	Maximum for any one day	Maximum for monthly average
mg/off-kg (lb/million off-lbs) of magnesium sawed or ground		
*Chromium	.009	.004
*Zinc	.029	.012
*Ammonia	2.600	1.140
*Fluoride	1.160	.515
Magnesium	.002	---
*Oil and Grease	.390	.234
*TSS	.800	.380
*pH	Within the range of 7.5 to 10.0 at all times	

BPT
Magnesium Forming
Degreasing Spent Solvents

There shall be no discharge of process wastewater pollutants.

BPT
Magnesium Forming
Wet Air Pollution Control Blowdown

Pollutant or pollutant property	Maximum for any one day	Maximum for monthly average
mg/off-kg (lb/million off-lbs) of magnesium formed		
*Chromium	.273	.112
*Zinc	.904	.378
*Ammonia	82.500	36.300
*Fluoride	36.900	16.400
Magnesium	.062	---
*Oil and Grease	12.400	7.430
*TSS	25.400	12.100
*pH	Within the range of 7.5 to 10.0 at all times	

Table IX-15
BPT REGULATORY FLOWS FOR
PRODUCTION OPERATIONS - NICKEL-COBALT FORMING SUBCATEGORY

Operation	Waste Stream	Normalized BPT Discharge		Production Normalizing Parameter
		l/kgg	gal/ton	
Rolling	Spent neat oils	0	0	
	Spent emulsions	170	40.9	Mass of nickel-cobalt rolled with emulsions
	Contact cooling water	3,770	905	Mass of nickel-cobalt rolled with water
Tube Reducing	Spent lubricants	0	0	
Drawing	Spent neat oils	0	0	
	Spent emulsions	95.4	22.9	Mass of nickel-cobalt drawn with emulsions
Extrusion	Spent lubricants	0	0	
	Press or solution heat treatment contact cooling water	83.2	20.0	Mass of nickel-cobalt extruded or heat treated and subsequently cooled with water
	Press hydraulic fluid leakage	232	55.6	Mass of nickel-cobalt extruded
Forging	Spent lubricants	0	0	
	Contact cooling water	474	114	Mass of forged nickel-cobalt cooled with water
	Equipment cleaning wastewater	40.0	9.57	Mass of nickel-cobalt forged on equipment requiring cleaning with water
	Press hydraulic fluid leakage	187	44.8	Mass of nickel-cobalt forged
Metal Powder Production	Atomization wastewater	2,620	629	Mass of nickel-cobalt metal powder produced by wet atomization
Stationary Casting	Contact cooling water	12,100	2,900	Mass of nickel-cobalt cast with stationary casting

1653

Table IX-15 (Continued)

BPT REGULATORY FLOWS FOR
PRODUCTION OPERATIONS - NICKEL-COBALT FORMING SUBCATEGORY

Operation	Waste Stream	Normalized BPT Discharge		Production Normalizing Parameter
		l/kgg	gal/ton	
Vacuum Melting	Steam condensate	0	0	
Annealing and Solution Heat Treatment	Contact cooling water	0	0	
Surface Treatment	Spent baths	935	224	Mass of nickel-cobalt surface treated
	Rinsewater	23,600	5,650	Mass of nickel-cobalt surface treated
Ammonia	Rinse	14.8	3.54	Mass of nickel-cobalt treated with ammonia solution
Alkaline Cleaning	Spent baths	33.9	8.13	Mass of nickel-cobalt alkaline cleaned
	Rinsewater	2,330	559	Mass of nickel-cobalt alkaline cleaned
Molten Salt	Rinsewater	8,440	2,020	Mass of nickel-cobalt treated with molten salt
Sawing or Grinding	Spent emulsions	39.4	9.45	Mass of nickel-cobalt sawed or ground with emulsions
	Rinsewater	1,810	435	Mass of sawed or ground nickel-cobalt rinsed
Steam Cleaning	Condensate	30.1	7.22	Mass of nickel-cobalt steam cleaned
Hydrostatic Tube Testing and Ultrasonic Testing	Wastewater	0	0	
Dye Penetrant Testing	Wastewater	213	50.9	Mass of nickel-cobalt tested with dye penetrant methods
Miscellaneous Wastewater Sources	Various	246	58.4	Mass of nickel-cobalt formed

1654

Table IX-15 (Continued)

BPT REGULATORY FLOWS FOR
PRODUCTION OPERATIONS - NICKEL-COBALT FORMING SUBCATEGORY

Operation	Waste Stream	Normalized BPT Discharge		Production Normalizing Parameter
		l/kg	gal/ton	
Degreasing	Spent solvents	0	0	
Wet Air Pollution Control	Blowdown	810	194	Mass of nickel-cobalt formed
Electrocoating	Rinsewater	3,370	807	Mass of nickel-cobalt electro- coated

Table IX-16

NICKEL-COBALT FORMING SUBCATEGORY
BPT EFFLUENT LIMITATIONS

BPT

Nickel-Cobalt Forming
Rolling Spent Neat Oils

There shall be no discharge of process wastewater
pollutants.

BPT

Nickel-Cobalt Forming
Rolling Spent Emulsions

Pollutant or pollutant property	Maximum for any one day	Maximum for monthly average
mg/off-kg (lb/million off-lbs) of nickel-cobalt rolled with emulsions		
Cadmium	.058	.026
*Chromium	.075	.031
Copper	.323	.170
Lead	.071	.034
*Nickel	.327	.216
Zinc	.248	.104
*Fluoride	10.100	4.490
*Oil and Grease	3.400	2.040
*TSS	6.970	3.320
*pH	Within the range of 7.5 to 10.0 at all times	

BPT

Nickel-Cobalt Forming
Rolling Contact Cooling Water

Pollutant or pollutant property	Maximum for any one day	Maximum for monthly average
mg/off-kg (lb/million off-lbs) of nickel-cobalt rolled with water		
Cadmium	1.280	.566
*Chromium	1.660	.679
Copper	7.170	3.770
Lead	1.590	.754
*Nickel	7.240	4.790
Zinc	5.510	2.300
*Fluoride	225.000	99.500
*Oil and Grease	75.400	45.300
*TSS	155.000	73.500
*pH	Within the range of 7.5 to 10.0 at all times	

Table IX-16 (Continued)

NICKEL-COBALT FORMING SUBCATEGORY
BPT EFFLUENT LIMITATIONS

BPT
Nickel-Cobalt Forming
Tube Reducing Spent Lubricants

There shall be no discharge of process wastewater pollutants.

BPT
Nickel-Cobalt Forming
Drawing Spent Neat Oils

There shall be no discharge of process wastewater pollutants.

BPT
Nickel-Cobalt Forming
Drawing Spent Emulsions

Pollutant or pollutant property	Maximum for any one day	Maximum for monthly average
mg/off-kg (lb/million off-lbs) of nickel-cobalt drawn with emulsions		
Cadmium	.033	.014
*Chromium	.042	.017
Copper	.181	.095
Lead	.040	.019
*Nickel	.183	.121
Zinc	.139	.058
*Fluoride	5.680	2.520
*Oil and Grease	1.910	1.150
*TSS	3.910	1.860
*pH	Within the range of 7.5 to 10.0 at all times	

BPT
Nickel-Cobalt Forming
Extrusion Spent Lubricants

There shall be no discharge of process wastewater pollutants.

Table IX-16 (Continued)

NICKEL-COBALT FORMING SUBCATEGORY
BPT EFFLUENT LIMITATIONS

BPT
Nickel-Cobalt Forming
Extrusion Press or Solution Heat Treatment Contact
Cooling Water

Pollutant or pollutant property	Maximum for any one day	Maximum for monthly average
mg/off-kg (lb/million off-lbs) of nickel-cobalt heat treated		
Cadmium	.028	.013
*Chromium	.037	.015
Copper	.158	.083
Lead	.035	.017
*Nickel	.160	.106
Zinc	.122	.051
*Fluoride	4.950	2.200
*Oil and Grease	1.670	.999
*TSS	3.410	1.620
*pH	Within the range of 7.5 to 10.0 at all times	

BPT
Nickel-Cobalt Forming
Extrusion Press Hydraulic Fluid Leakage

Pollutant or pollutant property	Maximum for any one day	Maximum for monthly average
mg/off-kg (lb/million off-lbs) of nickel-cobalt extruded		
Cadmium	.079	.035
*Chromium	.102	.042
Copper	.441	.232
Lead	.098	.046
*Nickel	.446	.295
Zinc	.339	.142
*Fluoride	13.800	6.130
*Oil and Grease	4.640	2.790
*TSS	9.510	4.530
*pH	Within the range of 7.5 to 10.0 at all times	

Table IX-16 (Continued)

NICKEL-COBALT FORMING SUBCATEGORY
BPT EFFLUENT LIMITATIONS

BPT
Nickel-Cobalt Forming
Forging Spent Lubricants

There shall be no discharge of process wastewater
pollutants.

BPT
Nickel-Cobalt Forming
Forging Contact Cooling Water

Pollutant or pollutant property	Maximum for any one day	Maximum for monthly average
mg/off-kg (lb/million off-lbs) of forged nickel-cobalt cooled with water		
Cadmium	.161	.071
*Chromium	.209	.085
Copper	.901	.474
Lead	.199	.095
*Nickel	.910	.602
Zinc	.692	.289
*Fluoride	28.200	12.500
*Oil and Grease	9.480	5.690
*TSS	19.500	9.250
*pH	Within the range of 7.5 to 10.0 at all times	

BPT Nickel-Cobalt Forming
Forging Equipment Cleaning Wastewater

Pollutant or pollutant property	Maximum for any one day	Maximum for monthly average
mg/off-kg (lb/million off-lbs) of nickel-cobalt forged		
Cadmium	.0136	.0060
*Chromium	.0176	.0072
Copper	.0760	.0400
Lead	.0168	.0080
*Nickel	.0768	.0508
Zinc	.0584	.0244
*Fluoride	2.3800	1.0600
*Oil and Grease	.8000	.4800
*TSS	1.6400	.7800
*pH	Within the range of 7.5 to 10.0 at all times	

Table IX-16 (Continued)

NICKEL-COBALT FORMING SUBCATEGORY
BPT EFFLUENT LIMITATIONS

BPT
Nickel-Cobalt Forming
Forging Press Hydraulic Fluid Leakage

Pollutant or pollutant property	Maximum for any one day	Maximum for monthly average
mg/off-kg (lb/million off-lbs) of nickel-cobalt forged		
Cadmium	.064	.028
*Chromium	.082	.034
Copper	.356	.187
Lead	.079	.037
*Nickel	.359	.238
Zinc	.273	.114
*Fluoride	11.100	4.940
*Oil and Grease	3.740	2.250
*TSS	7.670	3.650
*pH	Within the range of 7.5 to 10.0 at all times	

BPT
Nickel-Cobalt Forming
Metal Powder Production Atomization Wastewater

Pollutant or pollutant property	Maximum for any one day	Maximum for monthly average
mg/off-kg (lb/million off-lbs) of nickel-cobalt metal powder atomized		
Cadmium	.891	.393
*Chromium	1.150	.472
Copper	4.980	2.620
Lead	1.100	.524
*Nickel	5.030	3.330
Zinc	3.830	1.600
*Fluoride	156.000	69.200
*Oil and Grease	52.400	31.500
*TSS	108.000	51.100
*pH	Within the range of 7.5 to 10.0 at all times	

Table IX-16 (Continued)

NICKEL-COBALT FORMING SUBCATEGORY
BPT EFFLUENT LIMITATIONS

BPT
Nickel-Cobalt Forming
Stationary Casting Contact Cooling Water

Pollutant or pollutant property	Maximum for any one day	Maximum for monthly average
mg/off-kg (lb/million off-lbs) of nickel-cobalt cast with stationary casting methods		
Cadmium	4.120	1.820
*Chromium	5.330	2.180
Copper	23.000	12.100
Lead	5.080	2.420
*Nickel	23.300	15.400
Zinc	17.700	7.380
*Fluoride	720.000	320.000
*Oil and Grease	242.000	145.000
*TSS	496.000	236.000
*pH	Within the range of 7.5 to 10.0 at all times	

BPT
Nickel-Cobalt Forming
Vacuum Melting Steam Condensate

There shall be no discharge of process wastewater
pollutants.

BPT
Nickel-Cobalt Forming
Annealing and Solution Heat Treatment Contact Cooling Water

There shall be no discharge of process wastewater
pollutants.

Table IX-16 (Continued)

NICKEL-COBALT FORMING SUBCATEGORY
BPT EFFLUENT LIMITATIONS

BPT
Nickel-Cobalt Forming
Surface Treatment Spent Baths

Pollutant or pollutant property	Maximum for any one day	Maximum for monthly average
mg/off-kg (lb/million off-lbs) of nickel-cobalt surface treated		
Cadmium	.318	.140
*Chromium	.412	.169
Copper	1.780	.935
Lead	.393	.187
*Nickel	1.800	1.190
Zinc	1.370	.571
*Fluoride	55.700	24.700
*Oil and Grease	18.700	11.200
*TSS	38.400	18.300
*pH	Within the range of 7.5 to 10.0 at all times	

BPT
Nickel-Cobalt Forming
Surface Treatment Rinse

Pollutant or pollutant property	Maximum for any one day	Maximum for monthly average
mg/off-kg (lb/million off-lbs) of nickel-cobalt surface treated		
Cadmium	8.030	3.540
*Chromium	10.400	4.250
Copper	44.900	23.600
Lead	9.910	4.720
*Nickel	45.300	30.000
Zinc	34.500	14.400
*Fluoride	1,410.000	623.000
*Oil and Grease	472.000	283.000
*TSS	968.000	460.000
*pH	Within the range of 7.5 to 10.0 at all times	

Table IX-16 (Continued)

NICKEL-COBALT FORMING SUBCATEGORY
BPT EFFLUENT LIMITATIONS

BPT
Nickel-Cobalt Forming
Ammonia Rinse

Pollutant or pollutant property	Maximum for any one day	Maximum for monthly average
mg/off-kg (lb/million off-lbs) of nickel-cobalt treated with ammonia solution		
Cadmium	.005	.002
*Chromium	.007	.003
Copper	.028	.015
Lead	.006	.003
*Nickel	.028	.019
Zinc	.022	.009
*Fluoride	.881	.391
*Oil and Grease	.296	.178
*TSS	.607	.289
*pH	Within the range of 7.5 to 10.0 at all times	

BPT
Nickel-Cobalt Forming
Alkaline Cleaning Spent Baths

Pollutant or pollutant property	Maximum for any one day	Maximum for monthly average
mg/off-kg (lb/million off-lbs) of nickel-cobalt alkaline cleaned		
Cadmium	.012	.005
*Chromium	.015	.006
Copper	.064	.034
Lead	.014	.007
*Nickel	.065	.043
Zinc	.050	.021
*Fluoride	2.020	.895
*Oil and Grease	.678	.407
*TSS	1.390	.661
*pH	Within the range of 7.5 to 10.0 at all times	

Table IX-16 (Continued)

NICKEL-COBALT FORMING SUBCATEGORY
BPT EFFLUENT LIMITATIONS

BPT
Nickel-Cobalt Forming
Alkaline Cleaning Rinse

Pollutant or pollutant property	Maximum for any one day	Maximum for monthly average
mg/off-kg (lb/million off-lbs) of nickel-cobalt alkaline cleaned		
Cadmium	.792	.350
*Chromium	1.030	.420
Copper	4.430	2.330
Lead	.979	.466
*Nickel	4.480	2.960
Zinc	3.400	1.420
*Fluoride	139.000	61.500
*Oil and Grease	46.600	28.000
*TSS	95.600	45.500
*pH	Within the range of 7.5 to 10.0 at all times	

BPT
Nickel-Cobalt Forming
Molten Salt Rinse

Pollutant or pollutant property	Maximum for any one day	Maximum for monthly average
mg/off-kg (lb/million off-lbs) of nickel-cobalt treated with molten salt		
Cadmium	2.870	1.270
*Chromium	3.720	1.520
Copper	16.100	8.440
Lead	3.550	1.690
*Nickel	16.200	10.700
Zinc	12.300	5.150
*Fluoride	502.000	223.000
*Oil and Grease	169.000	101.000
*TSS	346.000	165.000
*pH	Within the range of 7.5 to 10.0 at all times	

Table IX-16 (Continued)

NICKEL-COBALT FORMING SUBCATEGORY
BPT EFFLUENT LIMITATIONS

BPT
Nickel-Cobalt Forming
Sawing or Grinding Spent Emulsions

Pollutant or pollutant property	Maximum for any one day	Maximum for monthly average
mg/off-kg (lb/million off-lbs) of nickel-cobalt sawed or ground with emulsions		
Cadmium	.013	.006
*Chromium	.017	.007
Copper	.075	.039
Lead	.017	.008
*Nickel	.076	.050
Zinc	.058	.024
*Fluoride	2.350	1.040
*Oil and Grease	.788	.473
*TSS	1.620	.769
*pH	Within the range of 7.5 to 10.0 at all times	

BPT
Nickel-Cobalt Forming
Sawing or Grinding Rinse

Pollutant or pollutant property	Maximum for any one day	Maximum for monthly average
mg/off-kg (lb/million off-lbs) of sawed or ground nickel-cobalt rinsed		
Cadmium	.616	.272
*Chromium	.797	.326
Copper	3.440	1.810
Lead	.760	.362
*Nickel	3.480	2.300
Zinc	2.640	1.110
*Fluoride	108.000	47.800
*Oil and Grease	36.200	21.700
*TSS	74.200	35.300
*pH	Within the range of 7.5 to 10.0 at all times	

Table IX-16 (Continued)

NICKEL-COBALT FORMING SUBCATEGORY
BPT EFFLUENT LIMITATIONS

BPT
Nickel-Cobalt Forming
Steam Cleaning Condensate

Pollutant or pollutant property	Maximum for any one day	Maximum for monthly average
mg/off-kg (lb/million off-lbs) of nickel-cobalt steam cleaned		
Cadmium	.010	.005
*Chromium	.013	.005
Copper	.057	.030
Lead	.013	.006
*Nickel	.058	.038
Zinc	.044	.018
*Fluoride	1.790	.795
*Oil and Grease	.602	.361
*TSS	1.240	.587
*pH	Within the range of 7.5 to 10.0 at all times	

BPT
Nickel-Cobalt Forming
Hydrostatic Tube Testing and Ultrasonic Testing
Wastewater

There shall be no discharge of process wastewater pollutants.

Table IX-16 (Continued)

NICKEL-COBALT FORMING SUBCATEGORY
BPT EFFLUENT LIMITATIONS

BPT

Nickel-Cobalt Forming
Dye Penetrant Testing Wastewater

Pollutant or pollutant property	Maximum for any one day	Maximum for monthly average
mg/off-kg (lb/million off-lbs) of nickel-cobalt tested with dye penetrant methods		
Cadmium	.072	.032
*Chromium	.094	.038
Copper	.405	.213
Lead	.090	.043
*Nickel	.409	.271
Zinc	.311	.130
*Fluoride	12.700	5.630
*Oil and Grease	4.260	2.560
*TSS	8.740	4.160
*pH	Within the range of 7.5 to 10.0 at all times	

BPT

Nickel-Cobalt Forming
Miscellaneous Wastewater Sources

Pollutant or pollutant property	Maximum for any one day	Maximum for monthly average
mg/off-kg (lb/million off-lbs) of nickel-cobalt formed		
Cadmium	.084	.037
*Chromium	.108	.044
Copper	.468	.246
Lead	.104	.049
*Nickel	.473	.313
Zinc	.359	.150
*Fluoride	14.700	6.500
*Oil and Grease	4.920	2.950
*TSS	10.100	4.800
*pH	Within the range of 7.5 to 10.0 at all times	

Table IX-16 (Continued)

NICKEL-COBALT FORMING SUBCATEGORY
BPT EFFLUENT LIMITATIONS

BPT
Nickel-Cobalt Forming
Degreasing Spent Solvents

There shall be no discharge of process wastewater pollutants.

BPT
Nickel-Cobalt Forming
Wet Air Pollution Control Blowdown

Pollutant or pollutant property	Maximum for any one day	Maximum for monthly average
mg/off-kg (lb/million off-lbs) of nickel-cobalt formed		
Cadmium	.276	.122
*Chromium	.357	.146
Copper	1.540	.810
Lead	.340	.162
*Nickel	1.560	1.030
Zinc	1.180	.494
*Fluoride	48.200	21.400
*Oil and Grease	16.200	9.720
*TSS	33.200	15.800
*pH	Within the range of 7.5 to 10.0 at all times	

Table IX-16 (Continued)

NICKEL-COBALT FORMING SUBCATEGORY
BPT EFFLUENT LIMITATIONS

BPT
Nickel-Cobalt Forming
Electrocoating Rinse

Pollutant or pollutant property	Maximum for any one day	Maximum for monthly average
mg/off-kg (lb/million off-lbs) of nickel-cobalt electrocoated		
Cadmium	1.150	.506
*Chromium	1.480	.607
Copper	6.410	3.370
Lead	1.420	.674
*Nickel	6.470	4.280
Zinc	4.920	2.060
*Fluoride	201.000	89.000
*Oil and Grease	67.400	40.500
*TSS	138.000	65.700
*pH	Within the range of 7.5 to 10.0 at all times	

Table IX-17

BPT REGULATORY FLOWS FOR
PRODUCTION OPERATIONS - PRECIOUS METALS FORMING SUBCATEGORY

Operation	Waste Stream	Normalized BPT Discharge		Production Normalizing Parameter
		l/kg	gal/ton	
Rolling	Spent neat oils	0	0	
	Spent emulsions	77.1	18.5	Mass of precious metals rolled with emulsions
Drawing	Spent neat oils	0	0	
	Spent emulsions	47.5	11.4	Mass of precious metals drawn with emulsions
	Spent soap solutions	3.12	0.748	Mass of precious metals drawn with soap solutions
Metal Powder Production	Wet atomization wastewater	6,680	1,600	Mass of precious metals powder produced by wet atomization
Casting				
Direct Chill Casting	Contact cooling water	10,800	2,590	Mass of precious metals cast by the direct chill method
Shot Casting	Contact cooling water	3,670	880	Mass of precious metals shot cast
Stationary Casting	Contact cooling water	0	0	
Semi-Continuous and Continuous Casting	Contact cooling water	10,300	2,480	Mass of precious metals cast by the semi-continuous or continuous method
Heat Treatment	Contact cooling water	4,170	1,000	Mass of extruded precious metals heat treated
Surface Treatment	Spent baths	96.3	23.1	Mass of precious metals surface treated
	Rinsewater	6,160	1,480	Mass of precious metals surface treated
Alkaline Cleaning	Spent baths	60.0	14.4	Mass of precious metals alkaline cleaned

Table IX-17 (Continued)

BPT REGULATORY FLOWS FOR
PRODUCTION OPERATIONS - PRECIOUS METALS FORMING SUBCATEGORY

Operation	Waste Stream	Normalized BPT Discharge		Production Normalizing Parameter
		l/kg	gal/ton	
Alkaline Cleaning	Rinsewater	11,200	2,690	Mass of precious metals alkaline cleaned
	Prebonding wastewater	11,600	2,770	Mass of precious metal and base metal cleaned prior to bonding
Tumbling or Burnishing	Wastewater	12,100	2,910	Mass of precious metals tumbled or burnished with water-based media
Sawing or Grinding	Spent neat oils	0	0	
	Spent emulsions	93.4	22.4	Mass of precious metals sawed or ground with emulsions
Pressure Bonding	Contact cooling water	83.5	20.0	Mass of precious metal and base metal pressure bonded and sub- sequently cooled with water
Degreasing	Spent solvents	0	0	
Wet Air Pollution Control	Blowdown	0	0	

1671

Table IX-18

PRECIOUS METALS FORMING SUBCATEGORY
BPT EFFLUENT LIMITATIONS

BPT
Precious Metals Forming
Rolling Spent Neat Oils

There shall be no discharge of process wastewater pollutants.

BPT
Precious Metals Forming
Rolling Spent Emulsions

Pollutant or pollutant property	Maximum for any one day	Maximum for monthly average
mg/off-kg (lb/million off-lbs) of precious metals rolled with emulsions		
*Cadmium	.026	.012
Chromium	.034	.014
*Copper	.147	.077
*Cyanide	.022	.009
*Lead	.032	.015
Nickel	.148	.098
*Silver	.032	.013
Zinc	.113	.047
*Oil and Grease	1.540	.925
*TSS	3.160	1.510
*pH	Within the range of 7.5 to 10.0 at all times	

BPT
Precious Metals Forming
Drawing Spent Neat Oils

There shall be no discharge of process wastewater pollutants.

Table IX-18

PRECIOUS METALS FORMING SUBCATEGORY
BPT EFFLUENT LIMITATIONS

BPT
Precious Metals Forming
Drawing Spent Emulsions

Pollutant or pollutant property	Maximum for any one day	Maximum for monthly average
mg/off-kg (lb/million off-lbs) of precious metals drawn with emulsions		
*Cadmium	.016	.007
Chromium	.021	.009
*Copper	.090	.048
*Cyanide	.014	.006
*Lead	.020	.010
Nickel	.091	.060
*Silver	.020	.008
Zinc	.069	.029
*Oil and Grease	.950	.570
*TSS	1.950	.926
*pH	Within the range of 7.5 to 10.0 at all times	

BPT
Precious Metals Forming
Drawing Spent Soap Solutions

Pollutant or pollutant property	Maximum for any one day	Maximum for monthly average
mg/off-kg (lb/million off-lbs) of precious metals drawn with soap solutions		
*Cadmium	.0011	.0005
Chromium	.0014	.0006
*Copper	.0059	.0031
*Cyanide	.0009	.0004
*Lead	.0013	.0006
Nickel	.0060	.0040
*Silver	.0013	.0005
Zinc	.0046	.0019
*Oil and Grease	.0624	.0375
*TSS	.1280	.0609
*pH	Within the range of 7.5 to 10.0 at all times	

Table IX-18 (Continued)

PRECIOUS METALS FORMING SUBCATEGORY
BPT EFFLUENT LIMITATIONS

BPT
Precious Metals Forming
Metal Powder Production Atomization Wastewater

Pollutant or pollutant property	Maximum for any one day	Maximum for monthly average
mg/off-kg (lb/million off-lbs) of precious metals powder wet atomized		
*Cadmium	2.270	1.000
Chromium	2.940	1.200
*Copper	12.700	6.680
*Cyanide	1.940	.802
*Lead	2.810	1.340
Nickel	12.800	8.490
*Silver	2.740	1.140
Zinc	9.750	4.080
*Oil and Grease	134.000	80.200
*TSS	274.000	130.000
*pH	Within the range of 7.5 to 10.0 at all times	

BPT
Precious Metals Forming
Direct Chill Casting Contact Cooling Water

Pollutant or pollutant property	Maximum for any one day	Maximum for monthly average
mg/off-kg (lb/million off-lbs) of precious metals cast by the direct chill method		
*Cadmium	3.670	1.620
Chromium	4.750	1.950
*Copper	20.500	10.800
*Cyanide	3.130	1.300
*Lead	4.540	2.160
Nickel	20.800	13.700
*Silver	4.430	1.840
Zinc	15.800	6.590
*Oil and Grease	216.000	130.000
*TSS	443.000	211.000
*pH	Within the range of 7.5 to 10.0 at all times	

Table IX-18 (Continued)

PRECIOUS METALS FORMING SUBCATEGORY
BPT EFFLUENT LIMITATIONS

BPT
Precious Metals Forming
Shot Casting Contact Cooling Water

Pollutant or pollutant property	Maximum for any one day	Maximum for monthly average
mg/off-kg (lb/million off-lbs) of precious metals shot cast		
*Cadmium	1.250	.551
Chromium	1.620	.661
*Copper	6.980	3.670
*Cyanide	1.070	.441
*Lead	1.540	.734
Nickel	7.050	4.660
*Silver	1.510	.624
Zinc	5.360	2.240
*Oil and Grease	73.400	44.100
*TSS	151.000	71.600
*pH	Within the range of 7.5 to 10.0 at all times	

BPT
Precious Metals Forming
Stationary Casting Contact Cooling Water

There shall be no discharge of process wastewater
pollutants.

Table IX-18 (Continued)

PRECIOUS METALS FORMING SUBCATEGORY
BPT EFFLUENT LIMITATIONS

BPT
Precious Metals Forming
Semi-Continuous and Continuous Casting Contact
Cooling Water

Pollutant or pollutant property	Maximum for any one day	Maximum for monthly average
mg/off-kg (lb/million off-lbs) of precious metals cast by the semi-continuous or continuous method		
*Cadmium	3.500	1.550
Chromium	4.530	1.860
*Copper	19.600	10.300
*Cyanide	2.990	1.240
*Lead	4.330	2.060
Nickel	19.800	13.100
*Silver	4.230	1.750
Zinc	15.100	6.290
*Oil and Grease	206.000	124.000
*TSS	423.000	201.000
*pH	Within the range of 7.5 to 10.0 at all times	

BPT
Precious Metals Forming
Heat Treatment Contact Cooling Water

Pollutant or pollutant property	Maximum for any one day	Maximum for monthly average
mg/off-kg (lb/million off-lbs) of extruded precious metals heat treated		
*Cadmium	1.420	.626
Chromium	1.840	.751
*Copper	7.930	4.170
*Cyanide	1.210	.501
*Lead	1.750	.834
Nickel	8.010	5.300
*Silver	1.710	.709
Zinc	6.090	2.550
*Oil and Grease	83.400	50.100
*TSS	171.000	81.300
*pH	Within the range of 7.5 to 10.0 at all times	

Table IX-18 (Continued)

PRECIOUS METALS FORMING SUBCATEGORY
BPT EFFLUENT LIMITATIONS

BPT
Precious Metals Forming
Surface Treatment Spent Baths

Pollutant or pollutant property	Maximum for any one day	Maximum for monthly average
mg/off-kg (lb/million off-lbs) of extruded precious metals heat treated		
*Cadmium	.033	.015
Chromium	.042	.017
*Copper	.183	.096
*Cyanide	.028	.012
*Lead	.041	.019
Nickel	.185	.123
*Silver	.040	.016
Zinc	.141	.059
*Oil and Grease	1.930	1.160
*TSS	3.950	1.880
*pH	Within the range of 7.5 to 10.0 at all times	

BPT
Precious Metals Forming
Surface Treatment Rinse

Pollutant or pollutant property	Maximum for any one day	Maximum for monthly average
mg/off-kg (lb/million off-lbs) of precious metals surface treated		
*Cadmium	2.100	.924
Chromium	2.710	1.110
*Copper	11.700	6.160
*Cyanide	1.790	.739
*Lead	2.590	1.230
Nickel	11.800	7.830
*Silver	2.530	1.050
Zinc	9.000	3.760
*Oil and Grease	123.000	73.900
*TSS	253.000	120.000
*pH	Within the range of 7.5 to 10.0 at all times	

Table IX-18 (Continued)

PRECIOUS METALS FORMING SUBCATEGORY
BPT EFFLUENT LIMITATIONS

BPT
Precious Metals Forming
Alkaline Cleaning Spent Baths

Pollutant or pollutant property	Maximum for any one day	Maximum for monthly average
mg/off-kg (lb/million off-lbs) of precious metals alkaline cleaned		
*Cadmium	.020	.009
Chromium	.026	.011
*Copper	.114	.060
*Cyanide	.017	.007
*Lead	.025	.012
Nickel	.115	.076
*Silver	.025	.010
Zinc	.088	.037
*Oil and Grease	1.200	.720
*TSS	2.460	1.170
*pH	Within the range of 7.5 to 10.0 at all times	

BPT
Precious Metals Forming
Alkaline Cleaning Rinse

Pollutant or pollutant property	Maximum for any one day	Maximum for monthly average
mg/off-kg (lb/million off-lbs) of precious metals alkaline cleaned		
*Cadmium	3.810	1.680
Chromium	4.930	2.020
*Copper	21.300	11.200
*Cyanide	3.250	1.350
*Lead	4.710	2.240
Nickel	21.500	14.200
*Silver	4.590	1.910
Zinc	16.400	6.830
*Oil and Grease	224.000	135.000
*TSS	459.000	219.000
*pH	Within the range of 7.5 to 10.0 at all times	

Table IX-18 (Continued)

PRECIOUS METALS FORMING SUBCATEGORY
BPT EFFLUENT LIMITATIONS

BPT
Precious Metals Forming
Alkaline Cleaning Prebonding Wastewater

Pollutant or pollutant property	Maximum for any one day	Maximum for monthly average
mg/off-kg (lb/million off-lbs) of precious metals and base metal cleaned prior to bonding		
*Cadmium	3.950	1.740
Chromium	5.110	2.090
*Copper	22.100	11.600
*Cyanide	3.370	1.390
*Lead	4.870	2.320
Nickel	22.300	14.800
*Silver	4.760	1.970
Zinc	17.000	7.080
*Oil and Grease	232.000	139.000
*TSS	476.000	226.000
*pH	Within the range of 7.5 to 10.0 at all times	

BPT
Precious Metals Forming
Tumbling or Burnishing Wastewater

Pollutant or pollutant property	Maximum for any one day	Maximum for monthly average
mg/off-kg (lb/million off-lbs) of precious metals tumbled or burnished		
*Cadmium	4.120	1.820
Chromium	5.330	2.180
*Copper	23.000	12.100
*Cyanide	3.510	1.450
*Lead	5.080	2.420
Nickel	23.300	15.400
*Silver	4.960	2.060
Zinc	17.700	7.380
*Oil and Grease	242.000	145.000
*TSS	496.000	236.000
*pH	Within the range of 7.5 to 10.0 at all times	

Table IX-18 (Continued)

PRECIOUS METALS FORMING SUBCATEGORY
BPT EFFLUENT LIMITATIONS

BPT
Precious Metals Forming
Sawing or Grinding Spent Neat Oils

There shall be no discharge of process wastewater pollutants.

BPT
Precious Metals Forming
Sawing or Grinding Spent Emulsions

Pollutant or pollutant property	Maximum for any one day	Maximum for monthly average
mg/off-kg (lb/million off-lbs) of precious metals sawed or ground with emulsions		
*Cadmium	.032	.014
Chromium	.041	.017
*Copper	.178	.093
*Cyanide	.027	.011
*Lead	.039	.019
Nickel	.180	.119
*Silver	.038	.016
Zinc	.137	.057
*Oil and Grease	1.870	1.120
*TSS	3.830	1.820
*pH	Within the range of 7.5 to 10.0 at all times	

Table IX-18 (Continued)

PRECIOUS METALS FORMING SUBCATEGORY
BPT EFFLUENT LIMITATIONS

BPT
Precious Metals Forming
Pressure Bonding Contact Cooling Water

Pollutant or pollutant property	Maximum for any one day	Maximum for monthly average
mg/off-kg (lb/million off-lbs) of precious metals and base metal pressure bonded		
*Cadmium	.028	.013
Chromium	.037	.015
*Copper	.159	.084
*Cyanide	.024	.010
*Lead	.035	.017
Nickel	.161	.106
*Silver	.034	.014
Zinc	.122	.051
*Oil and Grease	1.670	1.000
*TSS	3.430	1.630
*pH	Within the range of 7.5 to 10.0 at all times	

BPT
Precious Metals Forming
Degreasing Spent Solvents

There shall be no discharge of process wastewater
pollutants.

BPT
Precious Metals Forming
Wet Air Pollution Control Blowdown

There shall be no discharge of process wastewater
pollutants.

Table IX-19

BPT REGULATORY FLOWS FOR
 PRODUCTION OPERATIONS - REFRACTORY METALS FORMING SUBCATEGORY

Operation	Waste Stream	Normalized BPT Discharge		Production Normalizing Parameter
		l/kg	gal/ton	
Rolling	Spent neat oils and graphite-based lubricants	0	0	
	Spent emulsions	429	103	Mass of refractory metals rolled with emulsions
Drawing	Spent lubricants	0	0	
Extrusion	Spent lubricants	0	0	
	Press hydraulic fluid leakage	1,190	285	Mass of refractory metals extruded
Forging	Spent lubricants	0	0	
	Contact cooling water	323	77.5	Mass of forged refractory metals cooled with water
Metal Powder Production	Wastewater	281	67.3	Mass of refractory metals powder produced using water
	Floor wash water	0	0	
Metal Powder Pressing	Spent lubricants	0	0	
Surface Treatment	Spent baths	389	93.3	Mass of refractory metals surface treated
	Rinsewater	121,000	29,100	Mass of refractory metals surface treated
Alkaline Cleaning	Spent baths	334	80.2	Mass of refractory metals alkaline cleaned
	Rinsewater	816,000	196,000	Mass of refractory metals alkaline cleaned
Molten Salt	Rinsewater	6,330	1,520	Mass of refractory metals treated with molten salt
Tumbling or Burnishing	Wastewater	12,500	3,000	Mass of refractory metals tumbled or burnished with

1682

Table IX-19 (Continued)

BPT REGULATORY FLOWS FOR
PRODUCTION OPERATIONS - REFRACTORY METALS FORMING SUBCATEGORY

Operation	Waste Stream	Normalized BPT Discharge		Production Normalizing Parameter
		l/kg	gal/ton	
Sawing or Grinding	Spent neat oils	0	0	
	Spent emulsions	297	71.1	Mass of refractory metals sawed or ground with emulsions
	Contact cooling water	24,300	5,820	Mass of refractory metals sawed or ground with contact cooling water
	Rinsewater	135	32.5	Mass of refractory metals sawed or ground and subse- quently rinsed
Dye Penetrant Testing	Wastewater	77.6	18.6	Mass of refractory metals tested with dye penetrant methods
Equipment Cleaning	Wastewater	1,360	326	Mass of refractory metals formed on equipment requiring cleaning with water
Miscellaneous Wastewater Sources	Various	345	83.0	Mass of refractory metals formed
Degreasing	Spent solvents	0	0	
Wet Air Pollution Control	Blowdown	787	189	Mass of refractory metals sawed, ground, surface coated or surface treated

Table IX-20

REFRACTORY METALS FORMING SUBCATEGORY
BPT EFFLUENT LIMITATIONS

BPT
Refractory Metals Forming
Rolling Spent Neat Oils and Graphite-Based Lubricants

There shall be no discharge of process wastewater
pollutants.

BPT
Refractory Metals Forming
Rolling Spent Emulsions

Pollutant or pollutant property	Maximum for any one day	Maximum for monthly average
mg/off-kg (lb/million off-lbs) of refractory metals rolled with emulsions		
Chromium	.189	.077
*Copper	.815	.429
Lead	.180	.086
*Nickel	.824	.545
Silver	.176	.073
Zinc	.627	.262
Columbium	.052	---
*Fluoride	25.500	11.300
*Molybdenum	2.840	1.470
Tantalum	.193	---
Vanadium	.043	---
Tungsten	2.990	1.190
*Oil and Grease	8.580	5.150
*TSS	17.600	8.370
*pH	Within the range of 7.5 to 10.0 at all times	

BPT
Refractory Metals Forming
Drawing Spent Lubricants

There shall be no discharge of process wastewater
pollutants.

Table IX-20 (Continued)

REFRACTORY METALS FORMING SUBCATEGORY
BPT EFFLUENT LIMITATIONS

BPT
Refractory Metals Forming
Extrusion Spent Lubricants

There shall be no discharge of process wastewater pollutants.

BPT
Refractory Metals Forming
Extrusion Press Hydraulic Fluid Leakage

Pollutant or pollutant property	Maximum for any one day	Maximum for monthly average
mg/off-kg (lb/million off-lbs) of refractory metals extruded		
Chromium	.524	.214
*Copper	2.260	1.190
Lead	.500	.238
*Nickel	2.290	1.510
Silver	.488	.203
Zinc	1.740	.726
Columbium	.143	---
*Fluoride	70.800	31.400
*Molybdenum	7.870	4.070
Tantalum	.536	---
Vanadium	.119	---
Tungsten	8.280	3.310
*Oil and Grease	23.800	14.300
*TSS	48.800	23.200
*pH	Within the range of 7.5 to 10.0 at all times	

BPT
Refractory Metals Forming
Forging Spent Lubricants

There shall be no discharge of process wastewater pollutants.

Table IX-20 (Continued)

REFRACTORY METALS FORMING SUBCATEGORY
BPT EFFLUENT LIMITATIONSBPT
Refractory Metals Forming
Forging Contact Cooling Water

Pollutant or pollutant property	Maximum for any one day	Maximum for monthly average
mg/off-kg (lb/million off-lbs) of forged refractory metals cooled with water		
Chromium	.142	.058
*Copper	.614	.323
Lead	.136	.065
*Nickel	.620	.410
Silver	.133	.055
Zinc	.472	.197
Columbium	.039	---
*Fluoride	19.200	8.530
*Molybdenum	2.140	1.110
Tantalum	.146	---
Vanadium	.032	---
Tungsten	2.250	.898
*Oil and Grease	6.460	3.880
*TSS	13.300	6.300
*pH	Within the range of 7.5 to 10.0 at all times	

Table IX-20 (Continued)

REFRACTORY METALS FORMING SUBCATEGORY
BPT EFFLUENT LIMITATIONS

BPT
Refractory Metals Forming
Metal Powder Production Wastewater

Pollutant or pollutant property	Maximum for any one day	Maximum for monthly average
mg/off-kg (lb/million off-lbs) of refractory metals powder produced		
Chromium	.124	.051
*Copper	.534	.281
Lead	.118	.056
*Nickel	.540	.357
Silver	.115	.048
Zinc	.410	.172
Columbium	.034	---
*Fluoride	16.700	7.420
*Molybdenum	1.860	.961
Tantalum	.127	---
Vanadium	.028	---
Tungsten	1.960	.781
*Oil and Grease	5.620	3.370
*TSS	11.500	5.480
*pH	Within the range of 7.5 to 10.0 at all times	

BPT
Refractory Metals Forming
Metal Powder Production Floor Wash Water

There shall be no discharge of process wastewater
pollutants.

BPT
Refractory Metals Forming
Metal Powder Pressing Spent Lubricants

There shall be no discharge of process wastewater
pollutants.

Table IX-20 (Continued)

REFRACTORY METALS FORMING SUBCATEGORY
BPT EFFLUENT LIMITATIONSBPT
Refractory Metals Forming
Surface Treatment Spent Baths

Pollutant or pollutant property	Maximum for any one day	Maximum for monthly average
mg/off-kg (lb/million off-lbs) of refractory metals surface treated		
Chromium	.171	.070
*Copper	.739	.389
Lead	.164	.078
*Nickel	.747	.494
Silver	.160	.066
Zinc	.568	.237
Columbium	.047	---
*Fluoride	23.200	10.300
*Molybdenum	2.570	1.330
Tantalum	.175	---
Vanadium	.039	---
Tungsten	2.710	1.080
*Oil and Grease	7.780	4.670
*TSS	16.000	7.590
*pH	Within the range of 7.5 to 10.0 at all times	

Table IX-20 (Continued)

REFRACTORY METALS FORMING SUBCATEGORY
BPT EFFLUENT LIMITATIONS

BPT

Refractory Metals Forming
Surface Treatment Rinse

Pollutant or pollutant property	Maximum for any one day	Maximum for monthly average
mg/off-kg (lb/million off-lbs) of refractory metals surface treated		
Chromium	53.300	21.800
*Copper	230.000	121.000
Lead	50.800	24.200
*Nickel	233.000	154.000
Silver	49.600	20.600
Zinc	177.000	73.800
Columbium	14.500	---
*Fluoride	7,200.000	3,200.000
*Molybdenum	800.000	414.000
Tantalum	54.500	---
Vanadium	12.100	---
Tungsten	842.000	337.000
*Oil and Grease	2,420.000	1,450.000
*TSS	4,960.000	2,360.000
*pH	Within the range of 7.5 to 10.0 at all times	

Table IX-20 (Continued)

REFRACTORY METALS FORMING SUBCATEGORY
BPT EFFLUENT LIMITATIONSBPT
Refractory Metals Forming
Alkaline Cleaning Spent Baths

Pollutant or pollutant property	Maximum for any one day	Maximum for monthly average
mg/off-kg (lb/million off-lbs) of refractory metals alkaline cleaned		
Chromium	.147	.060
*Copper	.635	.334
Lead	.140	.067
*Nickel	.641	.424
Silver	.137	.057
Zinc	.488	.204
Columbium	.040	---
*Fluoride	19.900	8.820
*Molybdenum	2.210	1.140
Tantalum	.151	---
Vanadium	.033	---
Tungsten	2.330	.929
*Oil and Grease	6.680	4.010
*TSS	13.700	6.520
*pH	Within the range of 7.5 to 10.0 at all times	

Table IX-20 (Continued)

REFRACTORY METALS FORMING SUBCATEGORY
BPT EFFLUENT LIMITATIONSBPT
Refractory Metals Forming
Alkaline Cleaning Rinse

Pollutant or pollutant property	Maximum for any one day	Maximum for monthly average
mg/off-kg (lb/million off-lbs) of refractory metals alkaline cleaned		
Chromium	359.000	147.000
*Copper	1,550.000	816.000
Lead	343.000	163.000
*Nickel	1,570.000	1,040.000
Silver	335.000	139.000
Zinc	1,190.000	498.000
Columbium	97.900	---
*Fluoride	48,600.000	21,600.000
*Molybdenum	5,400.000	2,790.000
Tantalum	367.000	---
Vanadium	81.600	---
Tungsten	5,680.000	2,270.000
*Oil and Grease	16,300.000	9,790.000
*TSS	33,500.000	15,900.000
*pH	Within the range of 7.5 to 10.0 at all times	

Table IX-20 (Continued)

REFRACTORY METALS FORMING SUBCATEGORY
BPT EFFLUENT LIMITATIONSBPT
Refractory Metals Forming
Molten Salt Rinse

Pollutant or pollutant property	Maximum for any one day	Maximum for monthly average
mg/off-kg (lb/million off-lbs) of refractory metals treated with molten salt		
Chromium	2.790	1.140
*Copper	12.000	6.330
Lead	2.660	1.270
*Nickel	12.200	8.040
Silver	2.600	1.080
Zinc	9.240	3.860
Columbium	.760	---
*Fluoride	377.000	167.000
*Molybdenum	41.900	21.700
Tantalum	2.850	---
Vanadium	.633	---
Tungsten	44.100	17.600
*Oil and Grease	127.000	76.000
*TSS	260.000	124.000
*pH	Within the range of 7.5 to 10.0 at all times	

Table IX-20 (Continued)

REFRACTORY METALS FORMING SUBCATEGORY
BPT EFFLUENT LIMITATIONS

BPT

Refractory Metals Forming
Tumbling or Burnishing Wastewater

Pollutant or pollutant property	Maximum for any one day	Maximum for monthly average
mg/off-kg (lb/million off-lbs) of refractory metals tumbled or burnished		
Chromium	5.500	2.250
*Copper	23.800	12.500
Lead	5.250	2.500
*Nickel	24.000	15.900
Silver	5.130	2.130
Zinc	18.300	7.630
Columbium	1.500	---
*Fluoride	744.000	330.000
*Molybdenum	82.600	42.800
Tantalum	5.630	---
Vanadium	1.250	---
Tungsten	87.000	34.800
*Oil and Grease	250.000	150.000
*TSS	513.000	244.000
*pH	Within the range of 7.5 to 10.0 at all times	

BPT

Refractory Metals Forming
Sawing or Grinding Spent Neat Oils

There shall be no discharge of process wastewater
pollutants.

Table IX-20 (Continued)

REFRACTORY METALS FORMING SUBCATEGORY
BPT EFFLUENT LIMITATIONS

BPT
Refractory Metals Forming
Sawing or Grinding Spent Emulsions

Pollutant or pollutant property	Maximum for any one day	Maximum for monthly average
mg/off-kg (lb/million off-lbs) of refractory metals sawed or ground with emulsions		
Chromium	.131	.054
*Copper	.565	.297
Lead	.125	.059
*Nickel	.570	.377
Silver	.122	.051
Zinc	.434	.181
Columbium	.036	---
*Fluoride	17.700	7.840
*Molybdenum	1.970	1.020
Tantalum	.134	---
Vanadium	.030	---
Tungsten	2.070	.826
*Oil and Grease	5.940	3.570
*TSS	12.200	5.790
*pH	Within the range of 7.5 to 10.0 at all times	

Table IX-20 (Continued)

REFRACTORY METALS FORMING SUBCATEGORY
BPT EFFLUENT LIMITATIONSBPT
Refractory Metals Forming
Sawing or Grinding Contact Cooling Water

Pollutant or pollutant property	Maximum for any one day	Maximum for monthly average
mg/off-kg (lb/million off-lbs) of refractory metals sawed or ground with contact cooling water		
Chromium	10.700	4.380
*Copper	46.200	24.300
Lead	10.200	4.860
*Nickel	46.700	30.900
Silver	9.970	4.130
Zinc	35.500	14.800
Columbium	2.920	---
*Fluoride	1,450.000	642.000
*Molybdenum	161.000	83.100
Tantalum	11.000	---
Vanadium	2.430	---
Tungsten	169.000	67.600
*Oil and Grease	486.000	292.000
*TSS	997.000	474.000
*pH	Within the range of 7.5 to 10.0 at all times	

Table IX-20 (Continued)

REFRACTORY METALS FORMING SUBCATEGORY
BPT EFFLUENT LIMITATIONS

BPT

Refractory Metals Forming
Sawing or Grinding Rinse

Pollutant or pollutant property	Maximum for any one day	Maximum for monthly average
mg/off-kg (lb/million off-lbs) of sawed or ground refractory metals rinsed		
Chromium	.059	.024
*Copper	.257	.135
Lead	.057	.027
*Nickel	.259	.172
Silver	.055	.023
Zinc	.197	.082
Columbium	.016	---
*Fluoride	8.030	3.570
*Molybdenum	.893	.462
Tantalum	.061	---
Vanadium	.014	---
Tungsten	.940	.376
*Oil and Grease	2.700	1.620
*TSS	5.540	2.630
*pH	Within the range of 7.5 to 10.0 at all times	

Table IX-20 (Continued)

REFRACTORY METALS FORMING SUBCATEGORY
BPT EFFLUENT LIMITATIONS

BPT
Refractory Metals Forming
Dye Penetrant Testing Wastewater

Pollutant or pollutant property	Maximum for any one day	Maximum for monthly average
mg/off-kg (lb/million off-lbs) of refractory metals tested with dye penetrant methods		
Chromium	.034	.014
*Copper	.148	.078
Lead	.033	.016
*Nickel	.149	.099
Silver	.032	.013
Zinc	.113	.047
Columbium	.009	---
*Fluoride	4.620	2.050
*Molybdenum	.513	.266
Tantalum	.035	---
Vanadium	.008	---
Tungsten	.540	.216
*Oil and Grease	1.550	.931
*TSS	3.180	1.520
*pH	Within the range of 7.5 to 10.0 at all times	

Table IX-20 (Continued)

REFRACTORY METALS FORMING SUBCATEGORY
BPT EFFLUENT LIMITATIONSBPT
Refractory Metals Forming
Equipment Cleaning Wastewater

Pollutant or pollutant property	Maximum for any one day	Maximum for monthly average
mg/off-kg (lb/million off-lbs) of refractory metals formed		
Chromium	.599	.245
*Copper	2.590	1.360
Lead	.571	.272
*Nickel	2.610	1.730
Silver	.558	.231
Zinc	1.990	.830
Columbium	.163	---
*Fluoride	80.900	35.900
*Molybdenum	8.990	4.650
Tantalum	.612	---
Vanadium	.136	---
Tungsten	9.470	3.780
*Oil and Grease	27.200	16.300
*TSS	55.800	26.500
*pH	Within the range of 7.5 to 10.0 at all times	

Table IX-20 (Continued)

REFRACTORY METALS FORMING SUBCATEGORY
BPT EFFLUENT LIMITATIONS

BPT

Refractory Metals Forming
Miscellaneous Wastewater Sources

Pollutant or pollutant property	Maximum for any one day	Maximum for monthly average
mg/off-kg (lb/million off-lbs) of refractory metals formed		
Chromium	.152	.062
*Copper	.656	.345
Lead	.145	.069
*Nickel	.663	.438
Silver	.142	.059
Zinc	.504	.211
Columbium	.041	---
*Fluoride	20.500	9.110
*Molybdenum	2.280	1.180
Tantalum	.155	---
Vanadium	.035	---
Tungsten	2.400	.959
*Oil and Grease	6.900	4.140
*TSS	14.200	6.730
*pH	Within the range of 7.5 to 10.0 at all times	

Table IX-20 (Continued)

REFRACTORY METALS FORMING SUBCATEGORY
BPT EFFLUENT LIMITATIONS

BPT
Refractory Metals Forming
Degreasing Spent Solvents

There shall be no discharge of process wastewater pollutants.

BPT
Refractory Metals Forming
Wet Air Pollution Control Blowdown

Pollutant or pollutant property	Maximum for any one day	Maximum for monthly average
mg/off-kg (lb/million off-lbs) of refractory metals formed		
Chromium	.346	.142
*Copper	1.500	.787
Lead	.331	.158
*Nickel	1.510	1.000
Silver	.323	.134
Zinc	1.150	.480
Columbium	.095	---
*Fluoride	46.800	20.800
*Molybdenum	5.200	2.690
Tantalum	.354	---
Vanadium	.079	---
Tungsten	5.480	2.190
*Oil and Grease	15.800	9.450
*TSS	32.300	15.400
*pH	Within the range of 7.5 to 10.0 at all times	

Table IX-21

BPT REGULATORY FLOWS FOR
PRODUCTION OPERATIONS - TITANIUM FORMING SUBCATEGORY

Operation	Waste Stream	Normalized BPT Discharge		Production Normalizing Parameter
		l/kg	gal/ton	
Rolling	Spent neat oils	0	0	Mass of titanium rolled with contact cooling water
	Contact cooling water	4,880	1,170	
Drawing	Spent neat oils	0	0	
Extrusion	Spent neat oils	0	0	Mass of titanium extruded with emulsions
	Spent emulsions	71.9	17.2	
Forging	Press hydraulic fluid leakage	178	42.8	Mass of titanium extruded
	Spent lubricants	0	0	
	Contact cooling water	2,000	479	Mass of forged titanium cooled with water
	Equipment cleaning wastewater	40.0	9.60	Mass of titanium forged on equipment requiring cleaning with water
Tube Reducing	Press hydraulic fluid leakage	1,010	242	Mass of titanium forged
	Spent lubricants	0	0	
Heat Treatment	Contact cooling water	0	0	
Surface Treatment	Spent baths	208	49.9	Mass of titanium surface treated
	Rinsewater	29,200	7,000	Mass of titanium surface treated
Alkaline Cleaning	Spent baths	240	57.5	Mass of titanium alkaline cleaned
	Rinsewater	2,760	663	Mass of titanium alkaline cleaned

1701

Table IX-21 (Continued)
 BPT REGULATORY FLOWS FOR
 PRODUCTION OPERATIONS - TITANIUM FORMING SUBCATEGORY

Operation	Waste Stream	Normalized BPT Discharge		Production Normalizing Parameter
		l/kg	gal/ton	
Molten Salt	Rinsewater	955	229	Mass of titanium treated with molten salt
Tumbling	Wastewater	790	189	Mass of titanium tumbled with water-based media
Sawing or Grinding	Spent neat oils	0	0	
	Spent emulsions	183	43.8	Mass of titanium sawed or ground with an emulsion
	Contact cooling water	4,760	1,140	Mass of titanium sawed or ground with contact cooling water
Dye Penetrant Testing	Wastewater	1,120	268	Mass of titanium tested with dye penetrant methods
Miscellaneous Wastewater Sources	Various	32.4	7.77	Mass of titanium formed
Degreasing	Spent solvents	0	0	
Wet Air Pollution Control	Blowdown	2,140	514	Mass of titanium surface treated or forged

1702

Table IX-22

TITANIUM FORMING SUBCATEGORY
BPT EFFLUENT LIMITATIONS

BPT
Titanium Forming
Rolling Spent Neat Oils

There shall be no discharge of process wastewater pollutants.

BPT
Titanium Forming
Rolling Contact Cooling Water

Pollutant or pollutant property	Maximum for any one day	Maximum for monthly average
mg/off-kg (lb/million off-lbs) of titanium rolled with contact cooling water		
Chromium	2.150	.879
Copper	9.270	4.880
*Cyanide	1.420	.586
*Lead	2.050	.976
Nickel	9.370	6.200
*Zinc	7.130	2.980
*Ammonia	651.000	286.000
*Fluoride	291.000	129.000
Titanium	4.590	2.000
*Oil and Grease	97.600	58.600
*TSS	200.000	95.200
*pH	Within the range of 7.5 to 10.0 at all times	

BPT
Titanium Forming
Drawing Spent Neat Oils

There shall be no discharge of process wastewater pollutants.

BPT
Titanium Forming
Extrusion Spent Neat Oils

There shall be no discharge of process wastewater pollutants.

Table IX-22 (Continued)

TITANIUM FORMING SUBCATEGORY
BPT EFFLUENT LIMITATIONS

BPT
Titanium Forming
Extrusion Spent Emulsions

Pollutant or pollutant property	Maximum for any one day	Maximum for monthly average
mg/off-kg (lb/million off-lbs) of titanium extruded with emulsions		
Chromium	.032	.013
Copper	.137	.072
*Cyanide	.021	.009
*Lead	.030	.014
Nickel	.138	.091
*Zinc	.105	.044
*Ammonia	9.590	4.220
*Fluoride	4.280	1.900
Titanium	.068	.030
*Oil and Grease	1.440	.863
*TSS	2.950	1.400
*pH	Within the range of 7.5 to 10.0 at all times	

BPT
Titanium Forming
Extrusion Press Hydraulic Fluid Leakage

Pollutant or pollutant property	Maximum for any one day	Maximum for monthly average
mg/off-kg (lb/million off-lbs) of titanium extruded		
Chromium	.078	.032
Copper	.338	.178
*Cyanide	.052	.021
*Lead	.075	.036
Nickel	.342	.226
*Zinc	.260	.109
*Ammonia	23.700	10.500
*Fluoride	10.600	4.700
Titanium	.168	.073
*Oil and Grease	3.560	2.140
*TSS	7.300	3.470
*pH	Within the range of 7.5 to 10.0 at all times	

Table IX-22 (Continued)

TITANIUM FORMING SUBCATEGORY
BPT EFFLUENT LIMITATIONS

BPT
Titanium Forming
Forging Spent Lubricants

There shall be no discharge of process wastewater pollutants.

BPT
Titanium Forming
Forging Contact Cooling Water

Pollutant or pollutant property	Maximum for any one day	Maximum for monthly average
mg/off-kg (lb/million off-lbs) of forged titanium cooled with water		
Chromium	.880	.360
Copper	3.800	2.000
*Cyanide	.580	.240
*Lead	.840	.400
Nickel	3.840	2.540
*Zinc	2.920	1.220
*Ammonia	267.000	117.000
*Fluoride	119.000	52.800
Titanium	1.880	.820
*Oil and Grease	40.000	24.000
*TSS	82.000	39.000
*pH	Within the range of 7.5 to 10.0 at all times	

Table IX-22 (Continued)

TITANIUM FORMING SUBCATEGORY
BPT EFFLUENT LIMITATIONS

BPT
Titanium Forming
Forging Equipment Cleaning Wastewater

Pollutant or pollutant property	Maximum for any one day	Maximum for monthly average
mg/off-kg (lb/million off-lbs) of titanium forged		
Chromium	.018	.007
Copper	.076	.040
*Cyanide	.012	.005
*Lead	.017	.008
Nickel	.077	.051
*Zinc	.058	.024
*Ammonia	5.330	2.350
*Fluoride	2.380	1.060
Titanium	.038	.016
*Oil and Grease	.800	.480
*TSS	1.640	.780
*pH	Within the range of 7.5 to 10.0 at all times	

BPT
Titanium Forming
Forging Press Hydraulic Fluid Leakage

Pollutant or pollutant property	Maximum for any one day	Maximum for monthly average
mg/off-kg (lb/million off-lbs) of titanium forged		
Chromium	.445	.182
Copper	1.920	1.010
*Cyanide	.293	.121
*Lead	.424	.202
Nickel	1.940	1.280
*Zinc	1.480	.616
*Ammonia	135.000	59.200
*Fluoride	60.100	26.700
Titanium	.950	.414
*Oil and Grease	20.200	12.100
*TSS	41.400	19.700
*pH	Within the range of 7.5 to 10.0 at all times	

Table IX-22 (Continued)

TITANIUM FORMING SUBCATEGORY
BPT EFFLUENT LIMITATIONS

BPT
Titanium Forming
Tube Reducing Spent Lubricants

There shall be no discharge of process wastewater pollutants.

BPT
Titanium Forming
Heat Treatment Contact Cooling Water

There shall be no discharge of process wastewater pollutants.

BPT
Titanium Forming
Surface Treatment Spent Baths

Pollutant or pollutant property	Maximum for any one day	Maximum for monthly average
mg/off-kg (lb/million off-lbs) of titanium surface treated		
Chromium	.092	.038
Copper	.395	.208
*Cyanide	.060	.025
*Lead	.087	.042
Nickel	.400	.264
*Zinc	.304	.127
*Ammonia	27.700	12.200
*Fluoride	12.400	5.490
Titanium	.196	.085
*Oil and Grease	4.160	2.500
*TSS	8.530	4.060
*pH	Within the range of 7.5 to 10.0 at all times	

Table IX-22 (Continued)

TITANIUM FORMING SUBCATEGORY
BPT EFFLUENT LIMITATIONS

BPT
Titanium Forming
Surface Treatment Rinse

Pollutant or pollutant property	Maximum for any one day	Maximum for monthly average
mg/off-kg (lb/million off-lbs) of titanium surface treated		
Chromium	12.900	5.260
Copper	55.500	29.200
*Cyanide	8.470	3.510
*Lead	12.300	5.840
Nickel	56.100	37.100
*Zinc	42.700	17.800
*Ammonia	3,890.000	1,710.000
*Fluoride	1,740.000	771.000
Titanium	27.500	12.000
*Oil and Grease	584.000	351.000
*TSS	1,200.000	570.000
*pH	Within the range of 7.5 to 10.0 at all times	

BPT
Titanium Forming
Alkaline Cleaning Spent Baths

Pollutant or pollutant property	Maximum for any one day	Maximum for monthly average
mg/off-kg (lb/million off-lbs) of titanium alkaline cleaned		
Chromium	.106	.043
Copper	.456	.240
*Cyanide	.070	.029
*Lead	.101	.048
Nickel	.461	.305
*Zinc	.351	.147
*Ammonia	32.000	14.100
*Fluoride	14.300	6.340
Titanium	.226	.098
*Oil and Grease	4.800	2.880
*TSS	9.840	4.680
*pH	Within the range of 7.5 to 10.0 at all times	

Table IX-22 (Continued)

TITANIUM FORMING SUBCATEGORY
BPT EFFLUENT LIMITATIONS

BPT
Titanium Forming
Alkaline Cleaning Rinse

Pollutant or pollutant property	Maximum for any one day	Maximum for monthly average
mg/off-kg (lb/million off-lbs) of titanium alkaline cleaned		
Chromium	1.220	.497
Copper	5.250	2.760
*Cyanide	.801	.331
*Lead	1.160	.552
Nickel	5.300	3.510
*Zinc	4.030	1.690
*Ammonia	368.000	162.000
*Fluoride	164.000	72.900
Titanium	2.600	1.130
*Oil and Grease	55.200	33.100
*TSS	113.000	53.800
*pH	Within the range of 7.5 to 10.0 at all times	

BPT
Titanium Forming
Molten Salt Rinse

Pollutant or pollutant property	Maximum for any one day	Maximum for monthly average
mg/off-kg (lb/million off-lbs) of titanium treated with molten salt		
Chromium	.420	.172
Copper	1.820	.955
*Cyanide	.277	.115
*Lead	.401	.191
Nickel	1.840	1.210
*Zinc	1.400	.583
*Ammonia	128.000	56.000
*Fluoride	56.800	25.200
Titanium	.898	.392
*Oil and Grease	19.100	11.500
*TSS	39.200	18.600
*pH	Within the range of 7.5 to 10.0 at all times	

Table IX-22 (Continued)

TITANIUM FORMING SUBCATEGORY
BPT EFFLUENT LIMITATIONS

BPT
Titanium Forming
Tumbling Wastewater

Pollutant or pollutant property	Maximum for any one day	Maximum for monthly average
mg/off-kg (lb/million off-lbs) of titanium tumbled		
Chromium	.348	.142
Copper	1.500	.790
*Cyanide	.229	.095
*Lead	.332	.158
Nickel	1.520	1.010
*Zinc	1.160	.482
*Ammonia	106.000	46.300
*Fluoride	47.000	20.900
Titanium	.743	.324
*Oil and Grease	15.800	9.480
*TSS	32.400	15.400
*pH	Within the range of 7.5 to 10.0 at all times	

BPT
Titanium Forming
Sawing or Grinding Spent Neat Oils

There shall be no discharge of process wastewater
pollutants.

Table IX-22 (Continued)

TITANIUM FORMING SUBCATEGORY
BPT EFFLUENT LIMITATIONS

BPT
Titanium Forming
Sawing or Grinding Spent Emulsions

Pollutant or pollutant property	Maximum for any one day	Maximum for monthly average
mg/off-kg (lb/million off-lbs) of titanium sawed or ground with emulsions		
Chromium	.081	.033
Copper	.348	.183
*Cyanide	.053	.022
*Lead	.077	.037
Nickel	.352	.233
*Zinc	.267	.112
*Ammonia	24.400	10.700
*Fluoride	10.900	4.830
Titanium	.172	.075
*Oil and Grease	3.660	2.200
*TSS	7.510	3.570
*pH	Within the range of 7.5 to 10.0 at all times	

BPT
Titanium Forming
Sawing or Grinding Contact Cooling Water

Pollutant or pollutant property	Maximum for any one day	Maximum for monthly average
mg/off-kg (lb/million off-lbs) of titanium sawed or ground with contact cooling water		
Chromium	2.100	.857
Copper	9.050	4.760
*Cyanide	1.380	.571
*Lead	2.000	.952
Nickel	9.140	6.050
*Zinc	6.950	2.910
*Ammonia	635.000	279.000
*Fluoride	283.000	126.000
Titanium	4.480	1.950
*Oil and Grease	95.200	57.100
*TSS	195.000	92.800
*pH	Within the range of 7.5 to 10.0 at all times	

Table IX-22 (Continued)

TITANIUM FORMING SUBCATEGORY
BPT EFFLUENT LIMITATIONS

BPT
Titanium Forming
Dye Penetrant Testing Wastewater

Pollutant or pollutant property	Maximum for any one day	Maximum for monthly average
mg/off-kg (lb/million off-lbs) of titanium tested with dye penetrant methods		
Chromium	.493	.202
Copper	2.130	1.120
*Cyanide	.325	.135
*Lead	.471	.224
Nickel	2.150	1.420
*Zinc	1.640	.683
*Ammonia	149.000	65.700
*Fluoride	66.700	29.600
Titanium	1.050	.459
*Oil and Grease	22.400	13.500
*TSS	45.900	21.900
*pH	Within the range of 7.5 to 10.0 at all times	

BPT
Titanium Forming
Hydrotesting Wastewater

There shall be no discharge of process wastewater
pollutants.

Table IX-22 (Continued)

TITANIUM FORMING SUBCATEGORY
BPT EFFLUENT LIMITATIONS

BPT
Titanium Forming
Miscellaneous Wastewater Sources

Pollutant or pollutant property	Maximum for any one day	Maximum for monthly average
mg/off-kg (lb/million off-lbs) of titanium formed		
Chromium	.014	.005
Copper	.062	.032
*Cyanide	.009	.004
*Lead	.014	.006
Nickel	.062	.041
*Zinc	.047	.020
*Ammonia	4.320	1.900
*Fluoride	1.930	.856
Titanium	.031	.013
*Oil and Grease	.648	.389
*TSS	1.330	.632
*pH	Within the range of 7.5 to 10.0 at all times	

BPT
Titanium Forming
Degreasing Spent Solvents

There shall be no discharge of process wastewater
pollutants.

Table IX-22 (Continued)

TITANIUM FORMING SUBCATEGORY
BPT EFFLUENT LIMITATIONS

BPT
Titanium Forming
Wet Air Pollution Control Blowdown

Pollutant or pollutant property	Maximum for any one day	Maximum for monthly average
mg/off-kg (lb/million off-lbs) of titanium formed		
Chromium	.942	.385
Copper	4.070	2.140
*Cyanide	.621	.257
*Lead	.899	.428
Nickel	4.110	2.720
*Zinc	3.130	1.310
*Ammonia	285.000	126.000
*Fluoride	128.000	56.500
Titanium	2.010	.878
*Oil and Grease	42.800	25.700
*TSS	87.800	41.800
*pH	Within the range of 7.5 to 10.0 at all times	

Table IX-23

BPT REGULATORY FLOWS FOR
 PRODUCTION OPERATIONS - URANIUM FORMING SUBCATEGORY

Operation	Waste Stream	Normalized BPT Discharge		Production Normalizing Parameter
		l/kgg	gal/ton	
Extrusion	Spent lubricants	0	0	
	Tool contact cooling water	344	82.5	Mass of uranium extruded with tools requiring contact cooling with water
Forging	Spent lubricants	0	0	
Heat Treatment	Contact cooling water	1,900	455	Mass of extruded or forged uranium heat treated and subsequently cooled with water
Surface Treatment	Spent baths	27.2	6.52	Mass of uranium surface treated
	Rinsewater	337	80.9	Mass of uranium surface treated
Sawing or Grinding	Spent emulsions	5.68	1.36	Mass of uranium sawed or ground with emulsion
	Contact cooling water	1,650	395	Mass of uranium sawed or ground with contact cooling water
	Rinsewater	4.65	1.12	Mass of uranium sawed or ground and subsequently rinsed
Area Cleaning	Washwater	42.9	10.3	Mass of uranium formed
Degreasing	Spent solvents	0	0	

1715

Table IX-23 (Continued)
 BPT REGULATORY FLOWS FOR
 PRODUCTION OPERATIONS - URANIUM FORMING SUBCATEGORY

Operation	Waste Stream	Normalized BPT Discharge		Production Normalizing Parameter
		l/kg	gal/ton	
Wet Air Pollution Control	Blowdown	3.49	0.836	Mass of uranium surface treated
Drum Washwater	Wastewater	44.3	10.6	Mass of uranium formed
Laundry Washwater	Wastewater	52.4**	12.6**	Employee-day

*Liters/employee-day.

**Gallons/employee-day.

Table IX-24

URANIUM FORMING SUBCATEGORY
BPT EFFLUENT LIMITATIONS

BPT
Uranium Forming
Extrusion Spent Lubricants

There shall be no discharge of process wastewater
pollutants.

BPT
Uranium Forming
Extrusion Tool Contact Cooling Water

Pollutant or pollutant property	Maximum for any one day	Maximum for monthly average
mg/off-kg (lb/million off-lbs) of uranium extruded		
*Cadmium	.117	.052
*Chromium	.152	.062
*Copper	.654	.344
*Lead	.145	.069
*Nickel	.661	.437
Zinc	.502	.210
*Fluoride	20.500	9.080
*Molybdenum	2.280	1.180
Uranium	2.240	1.630
*Oil and Grease	6.880	4.130
*TSS	14.100	6.710
*pH	Within the range of 7.5 to 10.0 at all times	

BPT
Uranium Forming
Forging Spent Lubricants

There shall be no discharge of process wastewater
pollutants.

Table IX-24 (Continued)

URANIUM FORMING SUBCATEGORY
BPT EFFLUENT LIMITATIONS

BPT

Uranium Forming

Heat Treatment Contact Cooling Water

Pollutant or pollutant property	Maximum for any one day	Maximum for monthly average
mg/off-kg (lb/million off-lbs) of extruded or forged uranium heat treated		
*Cadmium	.646	.285
*Chromium	.836	.342
*Copper	3.610	1.900
*Lead	.798	.380
*Nickel	3.650	2.420
Zinc	2.780	1.160
*Fluoride	113.000	50.200
*Molybdenum	12.600	6.500
Uranium	12.400	8.990
*Oil and Grease	38.000	22.800
*TSS	77.900	37.100
*pH	Within the range of 7.5 to 10.0 at all times	

BPT

Uranium Forming

Surface Treatment Spent Baths

Pollutant or pollutant property	Maximum for any one day	Maximum for monthly average
mg/off-kg (lb/million off-lbs) of uranium surface treated		
*Cadmium	.009	.004
*Chromium	.012	.005
*Copper	.052	.027
*Lead	.011	.005
*Nickel	.052	.035
Zinc	.040	.017
*Fluoride	1.620	.718
*Molybdenum	.180	.093
Uranium	.177	.129
*Oil and Grease	.544	.327
*TSS	1.120	.531
*pH	Within the range of 7.5 to 10.0 at all times	

Table IX-24 (Continued)

URANIUM FORMING SUBCATEGORY
BPT EFFLUENT LIMITATIONS

BPT

Uranium Forming

Surface Treatment Rinse

Pollutant or pollutant property	Maximum for any one day	Maximum for monthly average
mg/off-kg (lb/million off-lbs) of uranium surface treated		
*Cadmium	.115	.051
*Chromium	.148	.061
*Copper	.641	.337
*Lead	.142	.067
*Nickel	.647	.428
Zinc	.492	.206
*Fluoride	20.100	8.900
*Molybdenum	2.230	1.150
Uranium	2.190	1.600
*Oil and Grease	6.740	4.050
*TSS	13.800	6.570
*pH	Within the range of 7.5 to 10.0 at all times	

BPT

Uranium Forming

Sawing or Grinding Spent Emulsions

Pollutant or pollutant property	Maximum for any one day	Maximum for monthly average
mg/off-kg (lb/million off-lbs) of uranium sawed or ground with emulsions		
*Cadmium	.0019	.0009
*Chromium	.0025	.0010
*Copper	.0108	.0057
*Lead	.0024	.0011
*Nickel	.0109	.0072
Zinc	.0083	.0035
*Fluoride	.3380	.1500
*Molybdenum	.0376	.0194
Uranium	.0369	.0269
*Oil and Grease	.1140	.0682
*TSS	.2330	.1110
*pH	Within the range of 7.5 to 10.0 at all times	

Table IX-24 (Continued)

URANIUM FORMING SUBCATEGORY
BPT EFFLUENT LIMITATIONS

BPT
Uranium Forming
Sawing or Grinding Contact Cooling Water

Pollutant or pollutant property	Maximum for any one day	Maximum for monthly average
mg/off-kg (lb/million off-lbs) of uranium sawed or ground with contact cooling water		
*Cadmium	.561	.248
*Chromium	.726	.297
*Copper	3.140	1.650
*Lead	.693	.330
*Nickel	3.170	2.100
Zinc	2.410	1.010
*Fluoride	98.200	43.600
*Molybdenum	10.900	5.650
Uranium	10.700	7.810
*Oil and Grease	33.000	19.800
*TSS	67.700	32.200
*pH	Within the range of 7.5 to 10.0 at all times	

BPT
Uranium Forming
Sawing or Grinding Rinse

Pollutant or pollutant property	Maximum for any one day	Maximum for monthly average
mg/off-kg (lb/million off-lbs) of sawed or ground uranium rinsed		
*Cadmium	.0016	.0007
*Chromium	.0021	.0008
*Copper	.0088	.0047
*Lead	.0020	.0009
*Nickel	.0089	.0059
Zinc	.0068	.0028
*Fluoride	.2770	.1230
*Molybdenum	.0308	.0159
Uranium	.0302	.0220
*Oil and Grease	.0930	.0558
*TSS	.1910	.0907
*pH	Within the range of 7.5 to 10.0 at all times	

Table IX-24 (Continued)

URANIUM FORMING SUBCATEGORY
BPT EFFLUENT LIMITATIONS

BPT
Uranium Forming
Area Cleaning Washwater

Pollutant or pollutant property	Maximum for any one day	Maximum for monthly average
mg/off-kg (lb/million off-lbs) of uranium formed		
*Cadmium	.015	.006
*Chromium	.019	.008
*Copper	.082	.043
*Lead	.018	.009
*Nickel	.082	.055
Zinc	.063	.026
*Fluoride	2.550	1.130
*Molybdenum	.284	.147
Uranium	.279	.203
*Oil and Grease	.858	.515
*TSS	1.760	.837
*pH	Within the range of 7.5 to 10.0 at all times	

BPT
Uranium Forming
Degreasing Spent Solvents

There shall be no discharge of process wastewater
pollutants.

Table IX-24 (Continued)

URANIUM FORMING SUBCATEGORY
BPT EFFLUENT LIMITATIONS

BPT
Uranium Forming
Wet Air Pollution Control Blowdown

Pollutant or pollutant property	Maximum for any one day	Maximum for monthly average
mg/off-kg (lb/million off-lbs) of uranium surface treated		
*Cadmium	.0012	.0005
*Chromium	.0015	.0006
*Copper	.0066	.0035
*Lead	.0015	.0007
*Nickel	.0067	.0044
Zinc	.0051	.0021
*Fluoride	.2080	.0922
*Molybdenum	.0231	.0120
Uranium	.0227	.0165
*Oil and Grease	.0698	.0419
*TSS	.1430	.0681
*pH	Within the range of 7.5 to 10.0 at all times	

BPT
Uranium Forming
Drum Washwater

Pollutant or pollutant property	Maximum for any one day	Maximum for monthly average
mg/off-kg (lb/million off-lbs) of uranium formed		
*Cadmium	.015	.007
*Chromium	.020	.008
*Copper	.084	.044
*Lead	.019	.009
*Nickel	.085	.056
Zinc	.065	.027
*Fluoride	2.640	1.170
*Molybdenum	.293	.152
Uranium	.288	.210
*Oil and Grease	.886	.532
*TSS	1.820	.864
*pH	Within the range of 7.5 to 10.0 at all times	

Table IX-24 (Continued)

URANIUM FORMING SUBCATEGORY
BPT EFFLUENT LIMITATIONS

BPT
Uranium Forming
Laundry Washwater

Pollutant or pollutant property	Maximum for any one day	Maximum for monthly average
<hr/> mg/employee-day uranium formed		
Cadmium	17.800	7.860
Chromium	23.100	9.430
Copper	99.600	52.400
Lead	22.000	10.500
Nickel	101.000	66.600
Zinc	76.500	32.000
Fluoride	3,120.000	1,390.000
Molybdenum	347.000	179.000
Uranium	341.000	248.000
Oil and Grease	1,050.000	629.000
TSS	2,150.000	1,020.000
pH	Within the range of 7.5 to 10.0 at all times	

Table IX-25
BPT REGULATORY FLOWS FOR
PRODUCTION OPERATIONS - ZINC FORMING SUBCATEGORY

Operation	Waste Stream	Normalized BPT Discharge		Production Normalizing Parameter
		l/kg	gal/ton	
Rolling	Spent neat oils	0	0	
	Spent emulsions	1.39	0.334	Mass of zinc rolled with emulsions
	Contact cooling water	536	129	Mass of zinc rolled with contact cooling water
Drawing	Spent emulsions	5.80	1.39	Mass of zinc drawn with emulsions
Casting				
Direct Chill Casting	Contact cooling water	505	121	Mass of zinc cast by the direct chill method
Stationary Casting	Contact cooling water	0	0	
Heat Treatment	Contact cooling water	763	183	Mass of zinc heat treated and subsequently cooled with water
Surface Treatment	Spent baths	88.7	21.3	Mass of zinc surface treated
	Rinsewater	3,580	859	Mass of zinc surface treated
Alkaline Cleaning	Spent baths	3.55	0.850	Mass of zinc alkaline cleaned
	Rinsewater	1,690	405	Mass of zinc alkaline cleaned
Sawing or Grinding	Spent emulsions	23.8	5.71	Mass of zinc sawed or ground with emulsions
Degreasing	Spent solvents	0	0	
Electrocoating	Rinsewater	2,290	550	Mass of zinc electrocoated

Table IX-26

ZINC FORMING SUBCATEGORY
BPT EFFLUENT LIMITATIONS

BPT
Zinc Forming
Rolling Spent Neat Oils

There shall be no discharge of process wastewater pollutants.

BPT
Zinc Forming
Rolling Spent Emulsions

Pollutant or pollutant property	Maximum for any one day	Maximum for monthly average
mg/off-kg (lb/million off-lbs) of zinc rolled with emulsions		
*Chromium	.0006	.0003
*Copper	.0026	.0014
*Cyanide	.0004	.0002
Nickel	.0027	.0018
*Zinc	.0020	.0009
*Oil and Grease	.0278	.0167
*TSS	.0570	.0271
*pH	Within the range of 7.5 to 10.0 at all times	

BPT
Zinc Forming
Rolling Contact Cooling Water

Pollutant or pollutant property	Maximum for any one day	Maximum for monthly average
mg/off-kg (lb/million off-lbs) of zinc rolled with contact cooling water		
*Chromium	.236	.097
*Copper	1.020	.536
*Cyanide	.156	.064
Nickel	1.030	.681
*Zinc	.783	.327
*Oil and Grease	10.700	6.430
*TSS	22.000	10.500
*pH	Within the range of 7.5 to 10.0 at all times	

Table IX-26 (Continued)

ZINC FORMING SUBCATEGORY
BPT EFFLUENT LIMITATIONSBPT
Zinc Forming
Drawing Spent Emulsions

Pollutant or pollutant property	Maximum for any one day	Maximum for monthly average
mg/off-kg (lb/million off-lbs) of zinc drawn with emulsions		
*Chromium	.0026	.0011
*Copper	.0110	.0058
*Cyanide	.0017	.0007
Nickel	.0112	.0074
*Zinc	.0085	.0035
*Oil and Grease	.1160	.0696
*TSS	.2380	.1130
*pH	Within the range of 7.5 to 10.0 at all times	

BPT
Zinc Forming
Direct Chill Casting Contact Cooling Water

Pollutant or pollutant property	Maximum for any one day	Maximum for monthly average
mg/off-kg (lb/million off-lbs) of zinc cast by the direct chill method		
*Chromium	.222	.091
*Copper	.960	.505
*Cyanide	.147	.061
Nickel	.970	.642
*Zinc	.738	.308
*Oil and Grease	10.100	6.060
*TSS	20.700	9.850
*pH	Within the range of 7.5 to 10.0 at all times	

Table IX-26 (Continued)

ZINC FORMING SUBCATEGORY
BPT EFFLUENT LIMITATIONS

BPT
Zinc Forming
Stationary Casting Contact Cooling Water

There shall be no discharge of process wastewater pollutants.

BPT
Zinc Forming
Heat Treatment Contact Cooling Water

Pollutant or pollutant property	Maximum for any one day	Maximum for monthly average
mg/off-kg (lb/million off-lbs) of zinc heat treated		
*Chromium	.336	.138
*Copper	1.450	.763
*Cyanide	.221	.092
Nickel	1.470	.969
*Zinc	1.120	.466
*Oil and Grease	15.300	9.160
*TSS	31.300	14.900
*pH	Within the range of 7.5 to 10.0 at all times	

BPT
Zinc Forming
Surface Treatment Spent Baths

Pollutant or pollutant property	Maximum for any one day	Maximum for monthly average
mg/off-kg (lb/million off-lbs) of zinc surface treated		
*Chromium	.039	.016
*Copper	.169	.089
*Cyanide	.026	.011
Nickel	.171	.113
*Zinc	.130	.054
*Oil and Grease	1.780	1.070
*TSS	3.640	1.730
*pH	Within the range of 7.5 to 10.0 at all times	

Table IX-26 (Continued)

ZINC FORMING SUBCATEGORY
BPT EFFLUENT LIMITATIONSBPT
Zinc Forming
Surface Treatment Rinse

Pollutant or pollutant property	Maximum for any one day	Maximum for monthly average
mg/off-kg (lb/million off-lbs) of zinc surface treated		
*Chromium	1.580	.645
*Copper	6.800	3.580
*Cyanide	1.040	.430
Nickel	6.880	4.550
*Zinc	5.230	2.190
*Oil and Grease	71.600	43.000
*TSS	147.000	69.800
*pH	Within the range of 7.5 to 10.0 at all times	

BPT
Zinc Forming
Alkaline Cleaning Spent Baths

Pollutant or pollutant property	Maximum for any one day	Maximum for monthly average
mg/off-kg (lb/million off-lbs) of zinc alkaline cleaned		
*Chromium	.0016	.0006
*Copper	.0068	.0036
*Cyanide	.0010	.0004
Nickel	.0068	.0045
*Zinc	.0052	.0022
*Oil and Grease	.0710	.0426
*TSS	.1460	.0692
*pH	Within the range of 7.5 to 10.0 at all times	

Table IX-26 (Continued)

ZINC FORMING SUBCATEGORY
BPT EFFLUENT LIMITATIONS

BPT
Zinc Forming
Alkaline Cleaning Rinse

Pollutant or pollutant property	Maximum for any one day	Maximum for monthly average
mg/off-kg (lb/million off-lbs) of zinc alkaline cleaned		
*Chromium	.744	.304
*Copper	3.210	1.690
*Cyanide	.490	.203
Nickel	3.250	2.150
*Zinc	2.470	1.030
*Oil and Grease	33.800	20.300
*TSS	69.300	33.000
*pH	Within the range of 7.5 to 10.0 at all times	

BPT
Zinc Forming
Sawing or Grinding Spent Emulsions

Pollutant or pollutant property	Maximum for any one day	Maximum for monthly average
mg/off-kg (lb/million off-lbs) of zinc sawed or ground with emulsions		
*Chromium	.011	.004
*Copper	.045	.024
*Cyanide	.007	.003
Nickel	.046	.030
*Zinc	.035	.015
*Oil and Grease	.476	.286
*TSS	.976	.464
*pH	Within the range of 7.5 to 10.0 at all times	

Table IX-26 (Continued)

ZINC FORMING SUBCATEGORY
BPT EFFLUENT LIMITATIONS

BPT
Zinc Forming
Degreasing Spent Solvents

There shall be no discharge of process wastewater pollutants.

BPT
Zinc Forming
Electrocoating Rinse

Pollutant or pollutant property	Maximum for any one day	Maximum for monthly average
mg/off-kg (lb/million off-lbs) of zinc electrocoated		
*Chromium	1.010	.412
*Copper	4.350	2.290
*Cyanide	.664	.275
Nickel	4.400	2.910
*Zinc	3.350	1.400
*Oil and Grease	45.800	27.500
*TSS	93.900	44.700
*pH	Within the range of 7.5 to 10.0 at all times	

Table-IX-27

BPT REGULATORY FLOWS FOR
 PRODUCTION OPERATIONS - ZIRCONIUM-HAFNIUM FORMING SUBCATEGORY

Operation	Waste Stream	Normalized BPT Discharge		Production Normalizing Parameter
		l/kg	gal/ton	
Rolling	Spent neat oils	0	0	
Drawing	Spent lubricants	0	0	
Extrusion	Spent lubricants	0	0	
	Press hydraulic fluid leakage	237	56.9	Mass of zirconium-hafnium extruded
Swaging	Spent neat oils	0	0	
Tube Reducing	Spent lubricants	0	0	
Heat Treatment	Contact cooling water	343	82.3	Mass of zirconium-hafnium heat treated and subsequently cooled with water
Surface Treatment	Spent baths	340	81.5	Mass of zirconium-hafnium surface treated
	Rinsewater	8,880	2,130	Mass of zirconium-hafnium surface treated
Alkaline Cleaning	Spent baths	1,600	384	Mass of zirconium-hafnium alkaline cleaned
	Rinsewater	31,400	7,530	Mass of zirconium-hafnium alkaline cleaned
Molten Salt	Rinsewater	7,560	1,810	Mass of zirconium-hafnium treated with molten salt

1731

Table IX-27 (Continued)
 BPT REGULATORY FLOWS FOR
 PRODUCTION OPERATIONS - ZIRCONIUM-HAFNIUM FORMING SUBCATEGORY

Operation	Waste Stream	Normalized BPT Discharge		Production Normalizing Parameter
		l/kgg	gal/ton	
Sawing or Grinding	Spent neat oils	0	0	
	Spent emulsions	281	67.4	Mass of zirconium-hafnium sawed or ground with emulsions
	Contact cooling water	321	77.0	Mass of zirconium-hafnium sawed or ground with contact, cooling water
	Rinsewater	1,800	431	Mass of zirconium-hafnium sawed or ground and subse- quently rinsed
Inspection and Testing	Wastewater	15.4	3.70	Mass of zirconium-hafnium tested
Degreasing	Spent solvents	0	0	
Wet Air Pollution Control	Blowdown	0	0	
Degreasing	Rinsewater	0	0	

1732

Table IX-28

ZIRCONIUM-HAFNIUM FORMING SUBCATEGORY
BPT EFFLUENT LIMITATIONS

BPT

Zirconium-Hafnium Forming
Rolling Spent Neat Oils

There shall be no discharge of process wastewater pollutants.

BPT

Zirconium-Hafnium Forming
Drawing Spent Lubricants

There shall be no discharge of process wastewater pollutants.

BPT

Zirconium-Hafnium Forming
Extrusion Spent Lubricants

There shall be no discharge of process wastewater pollutants.

BPT

Zirconium-Hafnium Forming
Extrusion Press Hydraulic Fluid Leakage

Pollutant or pollutant property	Maximum for any one day	Maximum for monthly average
mg/off-kg (lb/million off-lbs) of zirconium-hafnium extruded		
*Chromium	.104	.043
Copper	.451	.237
*Cyanide	.069	.029
Lead	.100	.047
*Nickel	.455	.301
Zinc	.346	.145
*Ammonia	31.600	13.900
*Fluoride	14.100	6.260
Zirconium	6.830	3.300
*Oil and Grease	4.740	2.850
*TSS	9.720	4.620
*pH	Within the range of 7.5 to 10.0 at all times	

Table IX-28 (Continued)

ZIRCONIUM-HAFNIUM FORMING SUBCATEGORY
BPT EFFLUENT LIMITATIONS

BPT
Zirconium-Hafnium Forming
Swaging Spent Neat Oils

There shall be no discharge of process wastewater pollutants.

BPT
Zirconium-Hafnium Forming
Tube Reducing Spent Lubricants

There shall be no discharge of process wastewater pollutants.

BPT
Zirconium-Hafnium Forming
Heat Treatment Contact Cooling Water

Pollutant or pollutant property	Maximum for any one day	Maximum for monthly average
mg/off-kg (lb/million off-lbs) of zirconium-hafnium heat treated		
*Chromium	.151	.062
Copper	.652	.343
*Cyanide	.100	.041
Lead	.144	.069
*Nickel	.659	.436
Zinc	.501	.209
*Ammonia	45.700	20.100
*Fluoride	20.400	9.060
Zirconium	9.880	4.770
*Oil and Grease	6.860	4.120
*TSS	14.100	6.690
*pH	Within the range of 7.5 to 10.0 at all times	

Table IX-28 (Continued)

ZIRCONIUM-HAFNIUM FORMING SUBCATEGORY
BPT EFFLUENT LIMITATIONS

BPT
Zirconium-Hafnium Forming
Surface Treatment Spent Baths

Pollutant or pollutant property	Maximum for any one day	Maximum for monthly average
mg/off-kg (lb/million off-lbs) of zirconium-hafnium surface treated		
*Chromium	.150	.061
Copper	.646	.340
*Cyanide	.099	.041
Lead	.143	.068
*Nickel	.653	.432
Zinc	.497	.208
*Ammonia	45.300	19.900
*Fluoride	20.300	8.980
Zirconium	9.790	4.730
*Oil and Grease	6.800	4.080
*TSS	14.000	6.630
*pH	Within the range of 7.5 to 10.0 at all times	

BPT
Zirconium-Hafnium Forming
Surface Treatment Rinse

Pollutant or pollutant property	Maximum for any one day	Maximum for monthly average
mg/off-kg (lb/million off-lbs) of zirconium-hafnium surface treated		
*Chromium	3.910	1.600
Copper	16.900	8.880
*Cyanide	2.580	1.070
Lead	3.730	1.780
*Nickel	17.100	11.300
Zinc	13.000	5.420
*Ammonia	1,190.000	521.000
*Fluoride	529.000	235.000
Zirconium	256.000	124.000
*Oil and Grease	178.000	107.000
*TSS	364.000	173.000
*pH	Within the range of 7.5 to 10.0 at all times	

Table IX-28 (Continued)

ZIRCONIUM-HAFNIUM FORMING SUBCATEGORY
BPT EFFLUENT LIMITATIONS

BPT
Zirconium-Hafnium Forming
Alkaline Cleaning Spent Baths

Pollutant or pollutant property	Maximum for any one day	Maximum for monthly average
mg/off-kg (lb/million off-lbs) of zirconium-hafnium alkaline cleaned		
*Chromium	.704	.288
Copper	3.040	1.600
*Cyanide	.464	.192
Lead	.672	.320
*Nickel	3.070	2.030
Zinc	2.340	.976
*Ammonia	213.000	93.800
*Fluoride	95.200	42.300
Zirconium	46.100	22.300
*Oil and Grease	32.000	19.200
*TSS	65.600	31.200
*pH	Within the range of 7.5 to 10.0 at all times	

BPT
Zirconium-Hafnium Forming
Alkaline Cleaning Rinse

Pollutant or pollutant property	Maximum for any one day	Maximum for monthly average
mg/off-kg (lb/million off-lbs) of zirconium-hafnium alkaline cleaned		
*Chromium	13.800	5.650
Copper	59.700	31.400
*Cyanide	9.110	3.770
Lead	13.200	6.280
*Nickel	60.300	39.900
Zinc	45.900	19.200
*Ammonia	4,190.000	1,840.000
*Fluoride	1,870.000	829.000
Zirconium	905.000	437.000
*Oil and Grease	628.000	377.000
*TSS	1,290.000	613.000
*pH	Within the range of 7.5 to 10.0 at all times	

Table IX-28 (Continued)

ZIRCONIUM-HAFNIUM FORMING SUBCATEGORY
BPT EFFLUENT LIMITATIONS

BPT
Zirconium-Hafnium Forming
Molten Salt Rinse

Pollutant or pollutant property	Maximum for any one day	Maximum for monthly average
mg/off-kg (lb/million off-lbs) of zirconium-hafnium treated with molten salt		
*Chromium	3.330	1.360
Copper	14.400	7.560
*Cyanide	2.190	.907
Lead	3.180	1.510
*Nickel	14.500	9.600
Zinc	11.100	4.610
*Ammonia	1,010.000	443.000
*Fluoride	450.000	200.000
Zirconium	218.000	105.000
*Oil and Grease	151.000	90.700
*TSS	310.000	148.000
*pH	Within the range of 7.5 to 10.0 at all times	

BPT
Zirconium-Hafnium Forming
Sawing or Grinding Spent Neat Oils

There shall be no discharge of process wastewater
pollutants.

Table IX-28 (Continued)

ZIRCONIUM-HAFNIUM FORMING SUBCATEGORY
BPT EFFLUENT LIMITATIONS

BPT
Zirconium-Hafnium Forming
Sawing or Grinding Spent Emulsions

Pollutant or pollutant property	Maximum for any one day	Maximum for monthly average
mg/off-kg (lb/million off-lbs) of zirconium-hafnium sawed or ground with emulsions		
*Chromium	.124	.051
Copper	.534	.281
*Cyanide	.082	.034
Lead	.118	.056
*Nickel	.540	.357
Zinc	.410	.172
*Ammonia	37.500	16.500
*Fluoride	16.700	7.420
Zirconium	8.090	3.910
*Oil and Grease	5.620	3.370
*TSS	11.500	5.480
*pH	Within the range of 7.5 to 10.0 at all times	

BPT
Zirconium-Hafnium Forming
Sawing or Grinding Contact Cooling Water

Pollutant or pollutant property	Maximum for any one day	Maximum for monthly average
mg/off-kg (lb/million off-lbs) of zirconium-hafnium sawed or ground with contact cooling water		
*Chromium	.141	.058
Copper	.610	.321
*Cyanide	.093	.039
Lead	.135	.064
*Nickel	.617	.408
Zinc	.469	.196
*Ammonia	42.800	18.800
*Fluoride	19.100	8.480
Zirconium	9.250	4.460
*Oil and Grease	6.420	3.850
*TSS	13.200	6.260
*pH	Within the range of 7.5 to 10.0 at all times	

Table IX-28 (Continued)

ZIRCONIUM-HAFNIUM FORMING SUBCATEGORY
BPT EFFLUENT LIMITATIONS

BPT

Zirconium-Hafnium Forming
Sawing or Grinding Rinse

Pollutant or pollutant property	Maximum for any one day	Maximum for monthly average
mg/off-kg (lb/million off-lbs) of sawed or ground zirconium-hafnium rinsed		
*Chromium	.792	.324
Copper	3.420	1.800
*Cyanide	.522	.216
Lead	.756	.360
*Nickel	3.460	2.290
Zinc	2.630	1.100
*Ammonia	240.000	106.000
*Fluoride	107.000	47.500
Zirconium	51.900	25.000
*Oil and Grease	36.000	21.600
*TSS	73.800	35.100
*pH	Within the range of 7.5 to 10.0 at all times	

BPT

Zirconium-Hafnium Forming
Inspection and Testing Wastewater

Pollutant or pollutant property	Maximum for any one day	Maximum for monthly average
mg/off-kg (lb/million off-lbs) of zirconium-hafnium tested		
*Chromium	.007	.003
Copper	.029	.015
*Cyanide	.004	.002
Lead	.006	.003
*Nickel	.030	.020
Zinc	.023	.009
*Ammonia	2.050	.903
*Fluoride	.917	.407
Zirconium	.444	.214
*Oil and Grease	.308	.185
*TSS	.632	.301
*pH	Within the range of 7.5 to 10.0 at all times	

Table IX-28 (Continued)

ZIRCONIUM-HAFNIUM FORMING SUBCATEGORY
BPT EFFLUENT LIMITATIONS

BPT
Zirconium-Hafnium Forming
Degreasing Spent Solvents

There shall be no discharge of process wastewater pollutants.

BPT
Zirconium-Hafnium Forming
Wet Air Pollution Control Blowdown

There shall be no allowance for the discharge of process wastewater pollutants.

BPT
Zirconium-Hafnium Forming
Degreasing Rinse

There shall be no discharge of process wastewater pollutants.

Table IX-29
BPT REGULATORY FLOWS FOR
PRODUCTION OPERATIONS - METAL POWDERS SUBCATEGORY

Operation	Waste Stream	Normalized BPT Discharge		Production Normalizing Parameter
		l/kg	gal/ton	
Metal Powder Production	Atomization wastewater	5,040	1,210	Mass of powder produced by wet atomization
Tumbling, Burnishing or Cleaning	Wastewater	4,400	1,050	Mass of powder metallurgy parts tumbled, burnished or cleaned with water-based media
Sawing or Grinding	Spent neat oils	0	0	
	Spent emulsions	18.1	4.33	Mass of powder metallurgy parts sawed or ground with emulsions
	Contact cooling water	1,620	389	Mass of powder metallurgy parts sawed or ground with contact cooling water
Sizing	Spent neat oils	0	0	
	Spent emulsions	14.6	3.50	Mass of powder sized using emulsions
Steam Treatment Wet Air Pollution Control	Blowdown	792	190	Mass of metallurgy parts steam treated
Oil-Resin Impregnation	Spent neat oils	0	0	
Degreasing	Spent solvents	0	0	
Hot Pressing	Contact cooling water	8,800	2,110	Mass of powder cooled with water after pressing
Mixing Wet Air Pollution Control	Blowdown	7,900	1,890	Mass of powder mixed

1741

Table IX-30

METAL POWDERS SUBCATEGORY
BPT EFFLUENT LIMITATIONS

BPT
Metal Powders
Metal Powder Production Atomization Wastewater

Pollutant or pollutant property	Maximum for any one day	Maximum for monthly average
mg/off-kg (lb/million off-lbs) of powder wet atomized		
Chromium	2.220	.907
*Copper	9.580	5.040
*Cyanide	1.460	.605
*Lead	2.120	1.010
Nickel	9.680	6.400
Zinc	7.360	3.080
Aluminum	32.400	16.100
Iron	6.050	3.080
*Oil and Grease	101.000	60.500
*TSS	207.000	98.300
*pH	Within the range of 7.5 to 10.0 at all times	

BPT
Metal Powders
Tumbling, Burnishing, or Cleaning Wastewater

Pollutant or pollutant property	Maximum for any one day	Maximum for monthly average
mg/off-kg (lb/million off-lbs) of powder metallurgy parts tumbled, burnished, or cleaned		
Chromium	1.940	.792
*Copper	8.360	4.400
*Cyanide	1.280	.528
*Lead	1.850	.880
Nickel	8.450	5.590
Zinc	6.430	2.690
Aluminum	28.300	14.100
Iron	5.280	2.690
*Oil and Grease	88.000	52.800
*TSS	181.000	85.800
*pH	Within the range of 7.5 to 10.0 at all times	

Table IX-30 (Continued)

METAL POWDERS SUBCATEGORY
BPT EFFLUENT LIMITATIONS

BPT
Metal Powders
Sawing or Grinding Spent Neat Oils

There shall be no discharge of process wastewater pollutants.

BPT
Metal Powders
Sawing or Grinding Spent Emulsions

Pollutant or pollutant property	Maximum for any one day	Maximum for monthly average
mg/off-kg (lb/million off-lbs) of powder metallurgy parts sawed or ground with emulsions		
Chromium	.008	.003
*Copper	.034	.018
*Cyanide	.005	.002
*Lead	.008	.004
Nickel	.035	.023
Zinc	.026	.011
Aluminum	.117	.058
Iron	.022	.011
*Oil and Grease	.362	.217
*TSS	.742	.353
*pH	Within the range of 7.5 to 10.0 at all times	

Table IX-30 (Continued)

METAL POWDERS SUBCATEGORY
BPT EFFLUENT LIMITATIONS

BPT
Metal Powders
Sawing or Grinding Contact Cooling Water

Pollutant or pollutant property	Maximum for any one day	Maximum for monthly average
mg/off-kg (lb/million off-lbs) of powder metallurgy parts sawed or ground with contact cooling water		
Chromium	.713	.292
*Copper	3.080	1.620
*Cyanide	.470	.195
*Lead	.681	.324
Nickel	3.110	2.060
Zinc	2.370	.988
Aluminum	10.400	5.190
Iron	1.950	.988
*Oil and Grease	32.400	19.500
*TSS	66.400	31.600
*pH	Within the range of 7.5 to 10.0 at all times	

BPT
Metal Powders
Sizing Spent Neat Oils

There shall be no discharge of process wastewater
pollutants.

Table IX-30 (Continued)

METAL POWDERS SUBCATEGORY
BPT EFFLUENT LIMITATIONSBPT
Metal Powders
Sizing Spent Emulsions

Pollutant or pollutant property	Maximum for any one day	Maximum for monthly average
mg/off-kg (lb/million off-lbs) of powder sized		
Chromium	.006	.003
*Copper	.028	.015
*Cyanide	.004	.002
*Lead	.006	.003
Nickel	.028	.019
Zinc	.021	.009
Aluminum	.094	.047
Iron	.018	.009
*Oil and Grease	.292	.175
*TSS	.599	.285
*pH	Within the range of 7.5 to 10.0 at all times	

BPT
Metal Powders
Steam Treatment Wet Air Pollution Control Blowdown

Pollutant or pollutant property	Maximum for any one day	Maximum for monthly average
mg/off-kg (lb/million off-lbs) of powder metallurgy parts steam treated		
Chromium	.349	.143
*Copper	1.510	.792
*Cyanide	.230	.095
*Lead	.333	.159
Nickel	1.520	1.010
Zinc	1.160	.483
Aluminum	5.090	2.540
Iron	.951	.483
*Oil and Grease	15.900	9.510
*TSS	32.500	15.500
*pH	Within the range of 7.5 to 10.0 at all times	

Table IX-30 (Continued)

METAL POWDERS SUBCATEGORY
BPT EFFLUENT LIMITATIONS

BPT
Metal Powders
Oil-Resin Impregnation Spent Neat Oils

There shall be no discharge of process wastewater pollutants.

BPT
Metal Powders
Degreasing Spent Solvents

There shall be no discharge of process wastewater pollutants.

BPT
Metal Powders
Hot Pressing Contact Cooling Water

Pollutant or pollutant property	Maximum for any one day	Maximum for monthly average
mg/off-kg (lb/million off-lbs) of powder cooled after pressing		
Chromium	3.870	1.590
*Copper	16.700	8.800
*Cyanide	2.550	1.060
*Lead	3.700	1.760
Nickel	16.900	11.200
Zinc	12.900	5.370
Aluminum	56.600	28.200
Iron	10.600	5.370
*Oil and Grease	176.000	106.000
*TSS	361.000	172.000
*pH	Within the range of 7.5 to 10.0 at all times	

Table IX-30 (Continued)

METAL POWDERS SUBCATEGORY
BPT EFFLUENT LIMITATIONS

BPT
Metal Powders
Mixing Wet Air Pollution Control Blowdown

Pollutant or pollutant property	Maximum for any one day	Maximum for monthly average
mg/off-kg (lb/million off-lbs) of powder mixed		
Chromium	3.480	1.420
*Copper	15.000	7.900
*Cyanide	2.290	.948
*Lead	3.320	1.580
Nickel	15.200	10.100
Zinc	11.600	4.820
Aluminum	50.800	25.300
Iron	9.480	4.820
*Oil and Grease	158.000	94.800
*TSS	324.000	154.000
*pH	Within the range of 7.5 to 10.0 at all times	

Table IX-31

ALLOWABLE DISCHARGE CALCULATIONS FOR REFRACTORY METALS
FORMING PLANT X IN EXAMPLE 1 (NICKEL)

Waste Stream	Average Daily Production (off-kg/day)	BPT Regulatory One-Day Maximum Ni Discharge (mg/off-kg)*	BPT Regulatory Monthly Average Ni Discharge (mg/off-kg)*	BPT Allowable One-Day Maximum Ni Discharge for Plant X (mg/day)	BPT Allowable Monthly Average Ni Discharge for Plant X (mg/day)
Refractory Metals Rolling Spent Emulsion	60	0.824	0.545	49.4	32.7

*These values are taken from Table IX-25 (Refractory Metals Forming Subcategory).

**Allowable discharge concentrations (mg/l) can be calculated by dividing these values by the plant's daily process water discharge (liters/day).

Table IX-32

ALLOWABLE DISCHARGE CALCULATIONS FOR LEAD-TIN-BISMUTH
FORMING PLANT Y IN EXAMPLE 2 (TOTAL SUSPENDED SOLIDS)

Waste Stream	Average Daily Production (off-kg/day)	BPT Regulatory One-Day Maximum TSS Discharge (mg/off-kg)*	BPT Regulatory Monthly Average TSS Discharge (mg/off-kg)*	BPT Allowable One-Day Maximum TSS Discharge for Plant Y (mg/day)	BPT Allowable Monthly Average TSS Discharge for Plant Y (mg/day)
Lead Shot Casting Contact Cooling Water	1,000	1.53	0.728	1,530	728
Lead Extrusion Press or Solution Heat Treatment Contact Cooling Water	4,200	59.1	28.1	248,220	118,020
Lead Extrusion Press Hydraulic Fluid Leakage	4,200	2.26	1.07	9,492	4,494
Lead Swaging Spent Emulsion	4,000	0.0726	0.0345	290	138
Lead Alkaline Cleaning Spent Bath	4,000	4.92	2.34	19,680	9,360

Table IX-32 (Continued)

ALLOWABLE DISCHARGE CALCULATIONS FOR LEAD-TIN-BISMUTH FORMING PLANT Y IN EXAMPLE 2 (TOTAL SUSPENDED SOLIDS)

Waste Stream	Average Daily Production (off-kg/day)	BPT Regulatory One-Day Maximum TSS Discharge (mg/off-kg)*	BPT Regulatory Monthly Average TSS Discharge (mg/off-kg)*	BPT Allowable One-Day Maximum TSS Discharge for Plant Y (mg/day)	BPT Allowable Monthly Average TSS Discharge for Plant Y (mg/day)
Lead Alkaline Cleaning Rinsewater	4,000	96.8	46.0	387,200	184,000
				<hr/> 666,412	<hr/> 316,740
				or 0.666 kg/day (1.47 lb/day)	or 0.317 kg/day (0.098 lb/day)

*These values are taken from Table IX-13 (Lead-Tin-Bismuth Forming Subcategory).

**Allowable discharge concentrations (mg/l) can be calculated by dividing these values by the plant's daily process water discharge (liters/day).

Table IX-33

ALLOWABLE DISCHARGE CALCULATIONS FOR NICKEL-COBALT AND TITANIUM
FORMING PLANT Z IN EXAMPLE 3 (NICKEL)

Waste Stream	Average Daily Production (off-kg/day)	BPT Regulatory One-Day Maximum Ni Discharge (mg/off-kg)*	BPT Regulatory Monthly Average Ni Discharge (mg/off-kg)*	BPT Allowable One-Day Maximum Ni Discharge for Plant Z (mg/day)	BPT Allowable Monthly Average Ni Discharge for Plant Z (mg/day)
Nickel Forging Contact Cooling Water	500	471	311	235,500	155,500
Nickel Surface Treatment Spent Bath	400	1.80	1.19	720	476
Nickel Surface Treatment Rinsewater	400	45.3	30.0	18,120	12,000
Nickel Wet Air Pollution Control Blowdown	400	1.56	1.03	624	412
Nickel Miscellaneous Wastewater Sources	500	0.473	0.313	236	156
Titanium Forging Contact Cooling Water	100	3.84	2.54	384	254
Titanium Surface Treatment Spent Bath	10	0.400	0.264	4	3
Titanium Surface Treatment Rinsewater	10	56.1	37.1	561	371

1751

Table IX-33 (Continued)

ALLOWABLE DISCHARGE CALCULATIONS FOR NICKEL-COBALT AND TITANIUM FORMING PLANT Z IN EXAMPLE 3 (NICKEL)

Waste Stream	Average Daily Production (off-kg/day)	BPT Regulatory One-Day Maximum Ni Discharge (mg/off-kg)*	BPT Regulatory Monthly Average Ni Discharge (mg/off-kg)*	BPT Allowable One-Day Maximum Ni Discharge for Plant Z (mg/day)	BPT Allowable Monthly Average Ni Discharge for Plant Z (mg/day)
Titanium Wet Air Pollution Control Scrubber Blowdown	10	4.11	2.72	41	27
Titanium Miscellaneous Wastewater Sources	0.11	0.062	0.041	6	4
				256,196	169,203
				or 0.256 kg/day (0.565 lb/day)	or 0.169 kg/day (0.373 lb/day)

*These values are taken from Tables IX-19 and IX-28 (Nickel-Cobalt Forming and Titanium Forming Subcategories, respectively).

**Allowable discharge concentrations (mg/l) can be calculated by dividing these values by the plant's daily process water discharge (liters/day).

Table IX-34

ALLOWABLE DISCHARGE CALCULATIONS FOR NICKEL-COBALT AND TITANIUM
FORMING PLANT Z IN EXAMPLE 3 (CYANIDE)

Waste Stream	Average Daily Production (off-kg/day)	BPT Regulatory One-Day Maximum CN Discharge (mg/off-kg)*	BPT Regulatory Monthly Average CN Discharge (mg/off-kg)*	BPT Allowable One-Day Maximum CN Discharge for Plant Z (mg/day)	BPT Allowable Monthly Average CN Discharge for Plant Z (mg/day)
Nickel Forging Contact Cooling Water	500	0	0	0	0
Nickel Surface Treatment Spent Bath	400	0	0	0	0
Nickel Surface Treatment Rinse-water	400	0	0	0	0
Nickel Surface Treatment Wet Air Pollution Control Blowdown	400	0	0	0	0
Nickel Miscellaneous Wastewater Sources	500	0	0	0	0
Titanium Forging Contact Cooling Water	100	0.580	0.240	58	24
Titanium Surface Treatment Spent Bath	10	0.061	0.025	0.61	0.25
Titanium Surface Treatment Rinsewater	10	8.47	3.51	84.7	35.1

1753

Table IX-34 (Continued)

ALLOWABLE DISCHARGE CALCULATIONS FOR NICKEL-COBALT AND TITANIUM FORMING PLANT Z IN EXAMPLE 3 (CYANIDE)

Waste Stream	Average Daily Production (off-kg/day)	BPT Regulatory One-Day Maximum CN Discharge (mg/off-kg)*	BPT Regulatory Monthly Average CN Discharge (mg/off-kg)*	BPT Allowable One-Day Maximum CN Discharge for Plant Z (mg/day)	BPT Allowable Monthly Average CN Discharge for Plant Z (mg/day)
Titanium Wet Air Pollution Control Scrubber Blowdown	10	0.621	0.257	6.21	2.57
Titanium Miscellaneous Wastewater Sources	0.1	0.010	0.004	1.0	0.4
				150.5	62.3
				or 1.5×10^{-4} kg/day (3.31×10^{-4} lb/day)	or 6.23×10^{-5} kg/day (13.74×10^{-4} lb/day)

*These values are taken from Tables IX-19 and IX-28 (Nickel-Cobalt Forming and Titanium Forming Subcategories, respectively).

**Allowable discharge concentrations (mg/l) can be calculated by dividing these values by the plant's daily process water discharge (liters/day).

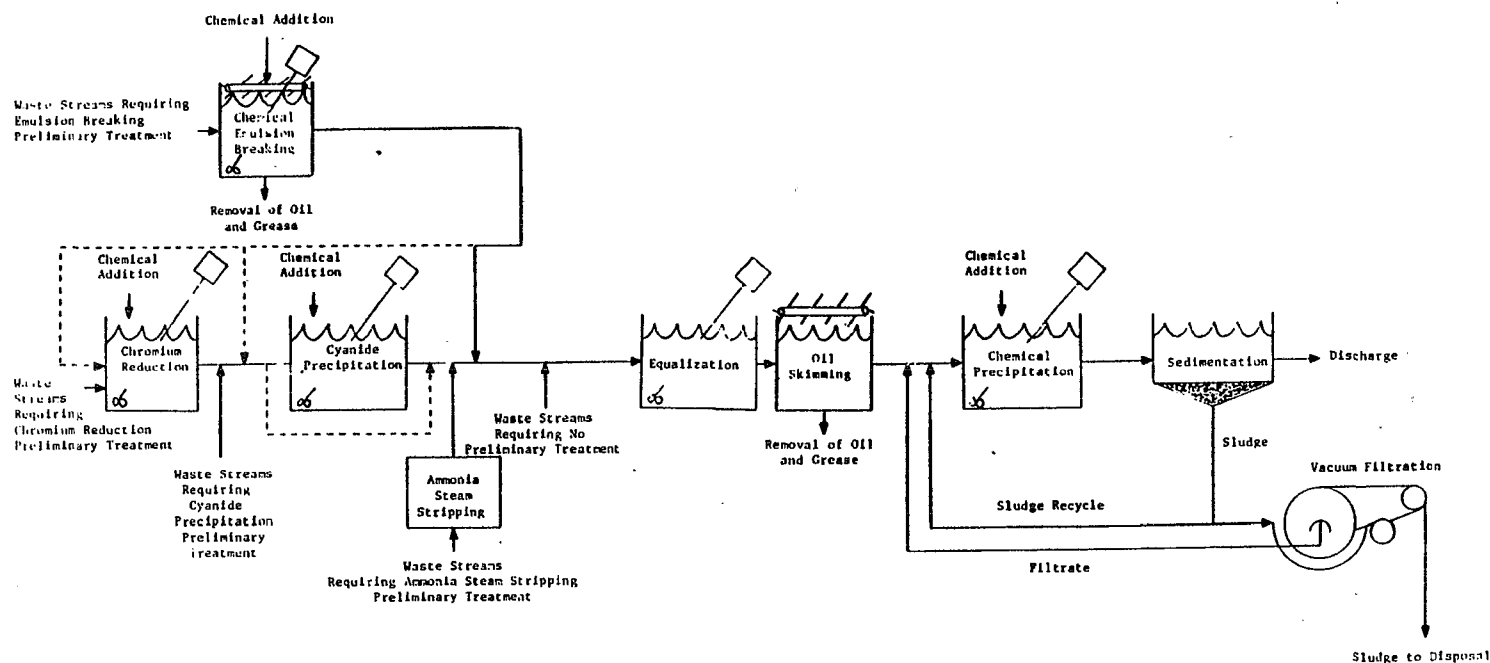

- NOTE: 1) Waste streams which may require specific preliminary treatment are listed in Table IX-1.
- 2) Chemical precipitation includes iron coprecipitation when necessary to remove molybdenum.

Figure IX-1

BPT TREATMENT TRAIN FOR THE NONFERROUS METALS FORMING CATEGORY

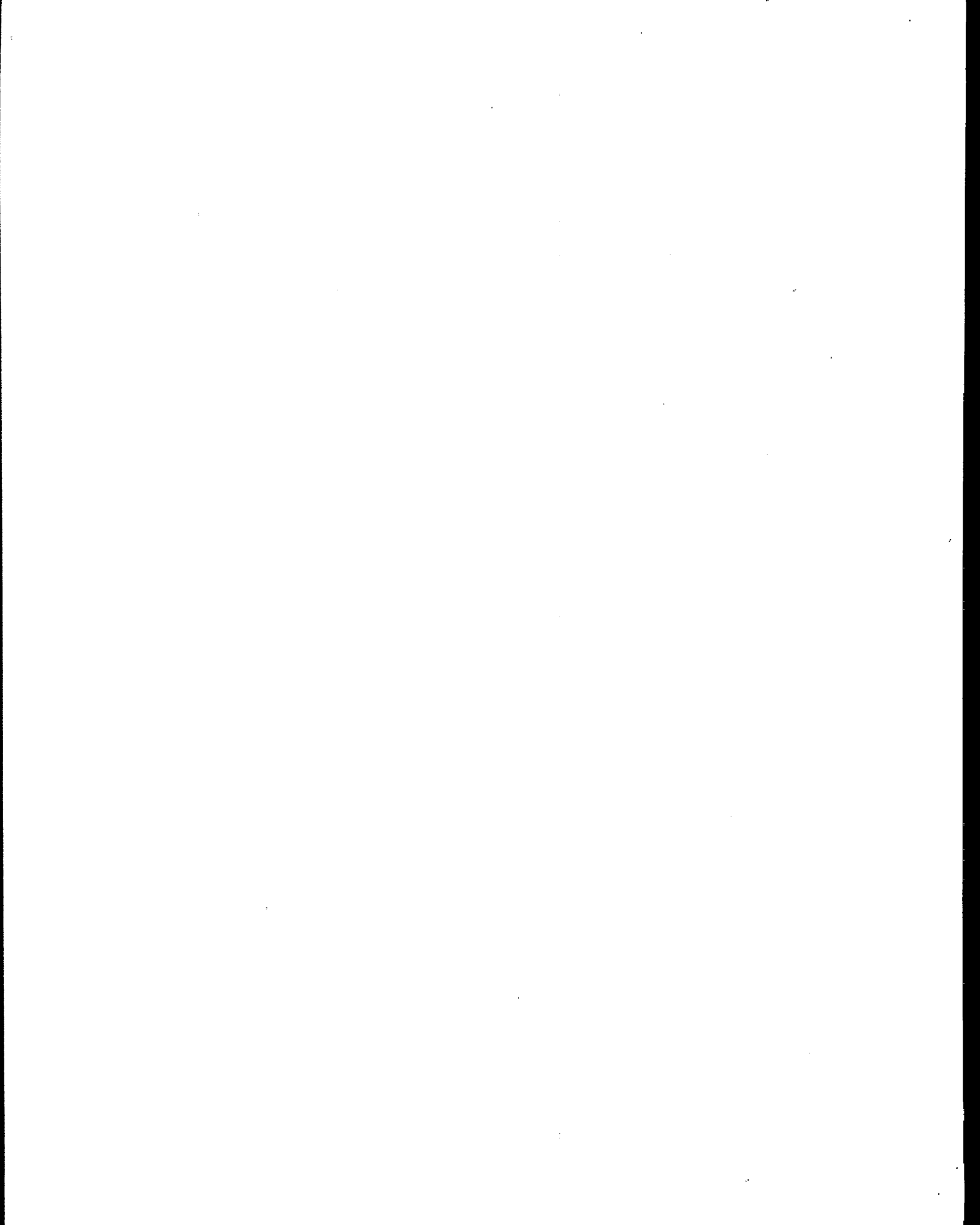

SECTION X

BEST AVAILABLE TECHNOLOGY ECONOMICALLY ACHIEVABLE

The effluent limitations in this section apply to existing direct dischargers. A direct discharger is a facility which discharges or may discharge pollutants into waters of the United States. These effluent limitations, which were to be achieved by July 1, 1984, are based on the best control and treatment technology employed by a specific point source within the industrial category or subcategory, or by another industry where it is readily transferable. Emphasis is placed on additional treatment techniques applied at the end of the treatment systems currently employed for BPT, as well as improvements in reagent control, process control, and treatment technology optimization.

The factors considered in assessing best available technology economically achievable (BAT) include the age of equipment and facilities involved, the process employed, process changes, nonwater quality environmental impacts (including energy requirements), and the costs of application of such technology. BAT technology represents the best existing economically achievable performance of plants of various ages, sizes, processes, or other characteristics. Those categories whose existing performance is uniformly inadequate may require a transfer of BAT from a different subcategory or category. BAT may include process changes or internal controls, even when these are not common industry practice. This level of technology also considers those plant processes and control and treatment technologies which at pilot plants and other levels have demonstrated both technological performance and economic viability at a level sufficient to justify investigation.

TECHNICAL APPROACH TO BAT

The Agency reviewed and evaluated a wide range of technology options to ensure that the most effective technologies were used as the basis of BAT. To accomplish this, the Agency examined three technology alternatives which could be applied to nonferrous metals forming as BAT options and which would represent substantial progress toward prevention of pollution of the environment above and beyond progress achievable by BPT. The statutory assessment of BAT considers costs, but does not require a balancing of costs against effluent reduction benefits [see *Weyerhaeuser v. Costle*, 11 ERC 2149 (D.C. Cir. 1978)]; however, in assessing the proposed BAT, the Agency has given substantial weight to the reasonableness of costs.

EPA evaluated three levels of BAT for the category at proposal. Option 1 is BPT treatment. Option 2 is BPT treatment plus flow reduction and in-plant controls. Option 3 provides additional levels of treatment, including filtration. Options 1, 2, and 3 technologies are, in general, equally applicable to all the subcategories of the nonferrous metals forming category. Each treatment produces similar concentrations of pollutants in the effluent from all subcategories. Mass limitations derived from these options will vary, however, because of the impact of different production normalized wastewater discharge flow allowances.

In summary form, the treatment technologies which were considered as BAT for the nonferrous metals forming category are:

Option 1 (Figure X-1):

- Oil skimming,
- Lime and settle (chemical precipitation of metals followed by sedimentation), and
- pH adjustment; and, where required,
- Iron coprecipitation,
- Chemical emulsion breaking,
- Ammonia steam stripping,
- Cyanide removal, and
- Hexavalent chromium reduction.

(This option is the technology on which BPT is based.)

Option 2 (Figure X-1):

Option 1, plus process wastewater flow reduction by the following methods:

- Contact cooling water recycle through cooling towers or holding tanks.
- Air pollution control scrubber liquor recycle. Countercurrent cascade rinsing or other water efficient methods applied to surface treatment rinses and alkaline cleaning rinses.
- Use of periodic batch discharges or decreased flow rate for molten salt rinse.
- Recycle of equipment cleaning wastewater, tumbling and burnishing wastewater, and other wastewater streams through holding tanks with provision for suspended solids removal, if necessary.

Option 3 (Figure X-2):

- Option 2, plus multimedia filtration at the end of the Option 2 treatment train. In addition to filtration, ion exchange was added to the end-of-pipe treatment train for the removal of gold, where necessary.

Option 1

Option 1 is the BPT end-of-pipe treatment technology. This treatment train depicted in Figure X-1 consists of preliminary treatment, when necessary, consisting of chemical emulsion breaking and oil skimming, ammonia steam stripping, cyanide removal, and hexavalent chromium reduction. The effluent from preliminary treatment is combined with other wastewaters for combined treatment by oil skimming and lime and settle Iron coprecipitation is added to the end-of-pipe treatment train when necessary to remove molybdenum.

Option 2

Option 2, depicted in Figure X-2, builds upon the BPT end-of-pipe treatment technologies by incorporating in-process flow reduction measures. The flow reduction measures eliminate some wastewater streams and concentrate the pollutants in others. Treatment of more concentrated streams allows a greater net removal of pollutants. Additionally, treating a reduced flow reduces costs. Methods for reducing process wastewater generation or discharge include:

Contact Cooling Water Recycle Through Cooling Towers or Holding Tanks. The cooling and recycle of contact cooling water from heat treatment and casting operations was reported for 50 operations in this category. Contact cooling water recycle is also demonstrated by nonferrous metals manufacturing plants, aluminum forming plants, copper forming plants, and metal molding and casting (foundry) plants. The function of contact cooling water is to remove heat quickly from the nonferrous metals. Therefore, the principal requirements of the water are that it be cool and not contain dissolved solids at a level that would cause water marks or other surface imperfections. There is sufficient industry experience to assure the success of recycle using cooling towers or heat exchangers. For operations with low cooling water flow rates, holding tanks should be sufficient to recycle the cooling water. Although no cooling water was reported to be discharged from 26 operations by reason of continued recycle, some blowdown or periodic cleaning is likely to be needed to prevent a build-up of dissolved and suspended solids.

Scrubber Liquor Recycle. The recycle of scrubber liquor from wet air pollution control devices was reported for 32 operations in this category. The scrubber water picks up particulates and fumes from the air. Scrubbers and other wet air pollution control devices have relatively low water quality requirements for efficient operation, accordingly, recycle of scrubber liquor is appropriate for nonferrous metals forming operations. For eight operations, complete recycle of scrubber water with no discharge is practiced. However, a blowdown or periodic cleaning may be necessary in some cases to prevent the build-up of dissolved and suspended solids.

Countercurrent Cascade Rinsing Applied to Surface Treatment Rinses and Alkaline Cleaning Rinses. Countercurrent cascade rinsing is a mechanism commonly encountered in nonferrous metals processing operations (see Section VII). The cleanest water is used for final rinsing of an item, preceded by rinse stages using water with progressively more contaminants to partially rinse the item. Fresh make-up water is added to the final rinse stage, and contaminated rinse water is discharged from the initial rinse stage. The make-up water for all but the final rinse stage is from the following stage.

The countercurrent cascade rinsing process substantially improves efficiencies of water use for rinsing. For example, the use of a two-stage countercurrent cascade rinse can reduce water usage to less than one-tenth of that needed for a single-stage rinse to achieve the same level of product cleanliness. Similarly, a three-stage countercurrent cascade rinse would reduce water usage to approximately one-hundredth. Through information supplied by plants in dcps or obtained during sampling visits by the Agency, countercurrent cascade rinsing is known to be practiced at six nonferrous metals forming plants. Most plants did not provide sufficient information in the dcp to classify the type of rinsing performed in their operations. Nonetheless, there is sufficient industry experience in countercurrent cascade rinsing to assume that a large number of plants use such rinsing operations. The installation of countercurrent cascade rinsing is applicable to existing nonferrous metals forming plants because surface treatment and alkaline cleaning operations are usually discrete operations and space is generally available for additional rinse tanks following these operations.

Periodic Batch Discharge or Decreased Flow Rate Applied to Molten Salt Rinse. Discharge flows from molten salt rinse operations can be significantly reduced by discharging the rinse on a periodic basis instead of continuously or by decreasing the rinse application rate. These flow reduction techniques are demonstrated at three plants in the nickel-cobalt forming subcategory, one plant in the refractory metals forming subcategory, and one plant in the zirconium-hafnium forming subcategory.

Recycle of Wastewater Through Holding Tanks With Suspended Solids Removal if Necessary. Discharge flows from a number of nonferrous metals forming operations can be significantly reduced by recycle through holding tanks. For streams with high concentrations of suspended solids, it may be necessary to add a suspended solids removal step such as filtration, centrifugation, or gravity settling to the recycle circuit. The recycle of wastewater after suspended solids removal is demonstrated at plants in the nonferrous metals forming category and in other point source categories such as battery manufacturing. For instance, at one nonferrous metals forming plant, over 90 percent of the wastewater from a tumbling operation is recycled through a centrifuge and holding tank. A few plants reported total recycle of some waste streams,

e.g., wastewater from one tumbling operation is completely recycled with no discharge. Although total recycle was reported by some plants, the Agency believes a blowdown or periodic cleaning may be necessary to prevent the build-up of dissolved solids and suspended solids in the recycle circuit.

Option 3

Option 3, depicted in Figure X-2, builds upon the technical requirements of Option 2 by adding conventional mixed-media filtration after the Option 2 technology treatment train. Ion exchange is added to the end-of-pipe treatment train for the precious metals forming subcategory for removal of gold and other precious metals.

The Agency briefly considered a fourth option, filtration without flow reduction. This option would have been equivalent to Option 1 with the addition of conventional mixed-media filtration after the Option 1 technology treatment train. However, flow reduction greatly reduces the size of the wastewater treatment system required, and hence its costs. Simultaneously, the efficiency of the treatment system is increased. For these reasons, the Agency concluded that filtration without flow reduction was not a practicable operation. Also, greater pollutant removals could be achieved by implementing in-process flow reduction prior to end-of-pipe treatments, including multimedia filtration. For waste streams which cannot be flow-reduced, this option is equivalent to Option 3.

Industry Cost and Environmental Benefits of the Various Treatment Options

The Agency estimated the costs and benefits of the implementation of each of the options described above in order to evaluate their economic achievability. The capital and annual costs of each option were estimated for each subcategory. Additional plant-specific information collected after proposal permitted the Agency to expand the scope of cost estimation from model plants representative of a costing group (the proposal cost methodology) to a plant-by-plant approach where compliance cost estimates are prepared for each plant. Plant-by-plant cost estimates were prepared for 149 discharging plants in the nonferrous metals forming category, including the 37 direct discharge plants. Total subcategory cost estimates are presented in Table X-1 for each option. The cost estimates for direct dischargers are presented in Table X-2. All costs are based on March 1982 dollars.

The cost methodology has been described in detail in Section VIII. As discussed in Section VIII, the plant-by-plant costs were estimated in one of three ways: (1) through use of a computer cost estimation model, (2) through use of cost curves, or (3) through scaling of costs from other similar facilities. Selecting the appropriate method for each plant was based primarily on the quality and timeliness of the information available

for that plant. Capital and annual costs are based on treatment of the total flow of process wastewater from each plant, regardless of its source. The cost of compliance with the nonferrous metals forming effluent limitations and standards was then determined as a portion of the total plant cost. Costs were also apportioned between subcategories when a plant had operations associated with more than one nonferrous metals forming subcategory. This costing methodology accounts for the fact that many nonferrous metals forming plants also generate wastewater from other industrial categories or generate wastewater from operations associated with more than one nonferrous metals forming subcategory. The costs for the 149 nonferrous metals forming plants were extrapolated to estimate the compliance cost for the additional nine plants for which detailed information was not available.

Capital and annual cost data for the selected treatment processes were obtained from three sources (1) equipment manufacturers, (2) literature data, and (3) cost data from existing plants. The major source of equipment costs was contacts with equipment vendors, while the majority of annual cost information was obtained from the literature. Additional cost and design data were obtained from data collection portfolios, when possible. Pollution reduction benefit estimates were calculated for each option for each subcategory. Total subcategory benefit estimates are presented in Tables X-3 through X-11. Benefits for direct dischargers are presented in Tables X-11 through X-20. Benefits for indirect dischargers are presented in Section XII.

The first step in the calculation of pollutant reduction benefit estimates was the calculation of production normalized raw waste values. The sampling data collected during the field sampling program and summarized in Section V were used to characterize the waste streams in each nonferrous metals forming subcategory. At each sampled facility, the sampling data were converted into production normalized values (i.e., mass of pollutants generated per mass of product manufactured) for each waste stream. The production normalized values, referred to as raw waste values in this document, were used to estimate the mass of pollutants generated in the subcategory.

The raw waste values for each pollutant were calculated by multiplying the pollutant concentration (mg/l) by the corresponding waste stream flow (l/unit time) and dividing this result by the corresponding production (kg/unit time) associated with generation of the waste stream. This calculation was performed for each raw wastewater sample. All raw waste values for a given waste stream were then averaged to determine the average raw waste value for the pollutant in that waste stream. The average raw waste value was used as the basis for estimating the mass of pollutant generated in the waste stream (kg/yr), also referred to as the raw waste generation. Average raw waste values were calculated for all waste streams for which sampling data were available at the time the benefit calculations were performed. When sampling data were not available for a given waste stream,

the raw waste values for a stream with similar water quality characteristics were used (see Section V of this document). The raw waste values used in the pollutant reduction benefit calculations are included in the public record supporting this regulation.

Pollutant reduction benefits were calculated for direct and indirect dischargers. The benefits for direct and indirect dischargers were then added to determine total subcategory benefits. The calculation of pollutant reduction benefits involves three basic steps: (1) calculation of raw waste generation, (2) calculation of pollutant discharges, and (3) calculation of pollutant removals. The raw waste generation (kg/yr) associated with both direct and indirect dischargers was calculated for each pollutant for each subcategory. To determine the total raw waste generation associated with direct or indirect dischargers for a given pollutant, the raw waste generation of that pollutant is determined for each waste stream in the subcategory and the results for the individual waste streams are added. The raw waste generation for individual waste streams is calculated by multiplying the total waste stream production for direct or indirect discharge plants (kkg/yr) by the average raw waste value for the pollutant in the waste stream ($\text{kkg/yr} \times \text{mg/kkg} - 1 \times 10^6 = \text{kg/yr}$).

The mass discharged (kg/yr) for each pollutant for each option was calculated for both direct and indirect dischargers in each subcategory. The pollutant discharge mass was calculated by multiplying the total flow (l/yr) for those waste streams which enter the treatment system, by the treatment effectiveness concentration (mg/l) (Table VII-21, p. xxxx) for each pollutant for the appropriate option. The total flow was determined by adding the flows for each individual stream discharged to treatment for the option under consideration. The flows for individual waste streams were calculated by multiplying the total direct or indirect discharger production for the waste stream (kkg/yr) by the production normalized regulatory flow (l/kkg) for the stream ($\text{kkg/yr} \times \text{l/kkg} = \text{l/yr}$).

The total mass of pollutant removed was calculated by subtracting the pollutant discharge mass (kg/yr) from the raw waste generation (kg/yr).

BAT OPTION SELECTION

The Agency evaluated the compliance costs and benefits for each of the options considered under BAT on a subcategory-by-subcategory basis. Compliance costs and benefits for the nonferrous metals forming category are presented in Tables X-1 through X-20. Both Options 2 and 3 provided additional pollutant reduction beyond that provided by Option 1, the option selected for BPT.

EPA has selected Option 3 as the basis for BAT effluent limitations in four subcategories and Option 2 as the basis for five subcategories. Option 1 was selected as the basis for the BAT limitations in one subcategory. Table X-23 presents a summary of the selected BAT option for each subcategory.

Option 3 has been selected as the basis for the BAT limitations for four subcategories because it increases pollutant removals over BPT and Option 2, and the incremental removals are high in relationship to the incremental costs. BAT limitations for the following subcategories are based on Option 3: nickel-cobalt forming, refractory metals forming, uranium forming, and zinc forming. Option 3 builds upon the technologies established for BPT. Flow reduction measures and multimedia filtration are the principal mechanisms for reducing pollutant discharges at this option. Flow reduction measures concentrate the pollutants in wastewater streams. Treatment of a more concentrated stream allows a greater net removal of pollutants. In addition, flow reduction lowers the cost of treatment by reducing the flow and hence pumping and chemical costs and the size of treatment equipment. In many cases, the costs for reducing a wastewater flow and treating the reduced flow with lime, settle, and multimedia filtration are less than the costs of treating a non-reduced wastewater flow by lime and settle alone. All of the flow reduction measures included in BAT are demonstrated in the nonferrous metals forming category as well as other point source categories.

Filtration is demonstrated at one plant in the nonferrous metals forming category and numerous plants in other point source categories as well.

Option 2 has been selected as the basis for BAT limitations for the following subcategories: lead-tin-bismuth forming, magnesium forming, precious metals forming, titanium forming, and zirconium-hafnium forming. Lime and settle treatment is particularly effective for these subcategories. When it is applied after flow reduction, the amount of toxic metal pollutants remaining in the wastewater is not significant. The application of filters after lime and settle treatment at lead-tin-bismuth forming, magnesium forming, precious metals forming, and zirconium-hafnium forming direct dischargers would remove less than 2 kg/yr of additional toxic metal pollutants, at an incremental cost of \$233,790. The addition of filters to the end-of-pipe treatment train for titanium forming direct dischargers would result in the removal of an additional 18.5 kg/yr of toxic metals, at an incremental cost of \$122,000. EPA believes that these costs are not justified by the amount or toxicity of the additional pollutants removed.

Option 1 has been selected as the basis for BAT limitations for the metal powders subcategory. None of the direct dischargers in this subcategory have any of the processes for which additional flow reduction measures above those included in the Option 1

model technology were added at Option 2. Since the Agency cannot show any incremental pollutant removal with the application of additional flow reduction technologies to direct dischargers, the BAT limitations are based on Option 1. Thus, BPT and BAT limitations for the metal powders subcategory are equal.

REGULATED POLLUTANT PARAMETERS

In each nonferrous metals forming subcategory, the raw wastewater concentrations from individual operations and the subcategory as a whole were examined to select those pollutant parameters found at frequencies and concentrations warranting regulation. In general, in each subcategory EPA has selected for regulation the two or three priority metals present at the highest concentrations in the raw waste, because in removing these two or three priority metals, the lime and settle treatment system also provides adequate removal of the priority and nonconventional metal pollutants present at lower concentrations. By establishing limitations for only two or three priority metal pollutants instead of all priority metals present at treatable concentrations, dischargers should attain the same degree of control as they would have been required to achieve had all priority metal pollutants been directly limited, with fewer monitoring and recordkeeping requirements.

In each subcategory, the metal pollutant present in the highest concentration is the metal being subjected to the forming operations. In several subcategories the metal pollutant present in the greatest amount is a priority pollutant (nickel in the nickel-cobalt forming subcategory, for example). In other subcategories, the metal pollutant present in greatest amount is a nonconventional pollutant (titanium in the titanium forming subcategory, for example). In general, EPA is not regulating nonconventional metal pollutants, even when they are the metal being formed. The Agency has concluded that regulation of just the priority metal pollutants will in most cases ensure the nonconventional metal pollutants are removed. Further, establishing regulations for only the priority metal pollutants allows plants greater flexibility in combining wastewater streams for treatment which are covered by more than one category or subcategory, because the pollutants controlled are more likely to be the same. However, EPA is regulating one nonconventional metal pollutant, molybdenum, in the refractory metals forming and uranium forming subcategories. A lime and settle system alone will not remove molybdenum adequately; it is necessary to add iron to coprecipitate molybdenum. Molybdenum is present in significant concentrations at refractory metals plants because it is one of the refractory metals being formed. It is also present in significant concentrations at uranium forming plants because it is used as a major alloying agent in depleted uranium alloys.

As discussed in Section VII, maintaining the correct pH in the treatment system is important to assure adequate removal of priority metal pollutants. The Agency believes that by maintaining the correct pH range for removal of the regulated

pollutants, removal of the other priority and nonconventional metal pollutants not specifically regulated should be assured. The Agency believes that the mechanism and the chemistry of priority metals removal in a lime and settle system are the same for all of the priority metals. This theoretical analysis is supported empirically by performance data of lime and settle systems collected by the Agency. The theoretical background metal priority pollutants removal as well as the performance have been presented in Section VII.

The Agency is also regulating certain priority and nonconventional pollutants which must be removed by preliminary treatment prior to combined wastewater treatment by lime and settle.

Hexavalent chromium is present in the surface treatment baths and rinses from some subcategories. Hexavalent chromium must be reduced to the trivalent form prior to combined end-of-pipe treatment, since only the trivalent form of chromium is removed by lime and settle treatment. Therefore, chromium is specifically regulated in some subcategories because preliminary chromium reduction is needed to ensure the removal of this pollutant when it is present in the hexavalent form. Total cyanide is regulated in subcategories where it is present at treatable concentrations, preliminary cyanide precipitation is needed to remove this pollutant from raw wastewater. Ammonia is regulated in subcategories where it was found at treatable concentrations; preliminary ammonia steam stripping is needed to remove the nonconventional pollutant ammonia.

Priority organic pollutants were found in two nonferrous metals forming waste streams. N-nitrosodiphenylamine was found in a significant amount in a sample of tube reducing lubricant. In addition, methylene chloride and toluene were found in the rinse which followed a solvent cleaning bath which contains these compounds. The Agency is requiring zero discharge from these wastewater streams. This requirement affects three subcategories: nickel-cobalt, titanium, and zirconium-hafnium. Tube reducing lubricants are currently hauled, rather than discharged by the majority of plants that generate this waste. Since they tend to be small in volume and highly concentrated, the Agency has concluded this is the most practical disposal alternative. These waste streams can be most economically handled by intercepting each such waste stream before mixing it with other process wastewaters and disposing of it as a solid waste. Treatment of the wastes with activated carbon after mixing it with other process wastewaters would be much more expensive. However, the Agency has provided an alternative to contract hauling for plants regulated by the nickel-cobalt forming or zirconium-hafnium forming subcategories. The Agency has provided no allowance for the discharge of process wastewater pollutants if the following conditions are met. Once each year the facility owner or operator, (1) demonstrates the absence of N-nitrosodiphenylamine, N-nitrosodimethylamine and N-nitrosodiphenylamine by sampling and analyzing spent tube reducing lubricant; and (2)

certifies that the tube reducing lubricants do not contain amine compounds, nitrates or nitrite.

Solvents are commonly used by nonferrous metals forming companies to clean oils from the surface of the metal; these processes are almost always dry. However, at one plant sampled after proposal, the Agency observed and sampled an organic solvent cleaning process that involves the generation of contaminated rinse. EPA is establishing a zero discharge allowance for this waste stream. Other plants perform the same process without generating any wastewater, by using solvents which need not be followed by a water rinse or by using cleaning agents other than solvents (e.g., detergents). EPA has based the zero discharge requirement on a process change which should achieve the same product quality as a water rinse at very little expense. Instead of operating a solvent bath followed by a water rinse, this plant can convert the water rinse into a second solvent cleaning step, or eliminate the use of solvents entirely. Treatment of this wastewater with activated carbon would be prohibitively expensive.

The Agency found 1,1,1-trichloroethane in small amounts in the nickel-cobalt, refractory metals, zirconium-hafnium and metal powders subcategories. The Agency also found chlorodibromomethane, bis(2-ethylhexyl) phthalate, and di-n-butyl phthalate in small amounts in zinc forming process wastewater. From the available data, the Agency believes these pollutants are unique to those sources and are not present as an integral part of the nonferrous forming process. Therefore, EPA is not regulating these pollutants. However, the permit writer should consider the possible presence of priority organic pollutants in nonferrous metals forming wastewater and, if found, should control them under this regulation on the basis of best professional judgment.

Regulation of priority metal pollutants does not ensure that fluoride will be adequately removed from raw wastewater since this pollutant precipitates from the lime and settle treatment system as calcium fluoride. Control of the metal pollutants requires the addition of an alkali to raise the pH and cause the metals to precipitate as hydroxides. As stated in Section VII, page xxxx, this alkali can be one of several agents. However, to remove fluoride and metals in the same treatment system, the alkali most commonly used is lime because it also contributes calcium that causes precipitation of fluoride. When fluoride is present at higher concentrations than metal pollutants, the addition of excess calcium may be necessary to remove fluoride to the treatment effectiveness concentration shown in Table VII-21 (page). Therefore, fluoride is specifically regulated in the six subcategories in which it was found at treatable concentrations.

The conventional pollutant parameters oil and grease, total suspended solids, and pH are not regulated under BAT. These pollutants parameters are regulated under the best conventional technology (BCT) effluent limitations. As discussed in Section XIII, the BCT effluent limitations guidelines will be developed after EPA promulgates a final BCT methodology.

LEAD-TIN-BISMUTH FORMING SUBCATEGORY

Discharge Flows

Table X-24 lists the BAT regulatory flows for waste streams in the lead-tin-bismuth forming subcategory. All waste streams which received a BPT flow allowance also receive an allowance under BAT. The regulatory flows for four waste streams have been decreased at BAT based on the application of in-process flow reduction control measures. The four flow reduced waste streams are: extrusion press and solution heat treatment contact cooling water, semi-continuous ingot casting contact cooling water, shot forming wet air pollution control blowdown, and alkaline cleaning rinse. Calculation of the BAT regulatory flows for these four flow reduced streams is discussed below. The BAT regulatory flows for all other waste streams in the subcategory are equal to the BPT regulatory flow discussed in Section IX.

Lead-Tin-Bismuth Extrusion Press and Solution Heat Treatment Contact Cooling Water. The BAT regulatory flow for this stream is 144 l/kg (34.6 gal/ton). The BAT regulatory flow is 90 percent reduction of the BPT flow, based on recycle through a cooling tower or holding tank. Holding tanks are used in place of cooling towers for streams with low flow rates. Extrusion press and solution heat treatment contact cooling water from three operations in this subcategory is completely recycled with no discharge while cooling water from a fourth operation is recycled and periodically contract hauled. The recycle of heat treatment contact cooling water is demonstrated in other nonferrous metals forming subcategories and other point source categories as well. Although the cooling water from three operations in this subcategory was reported to be completely recycled with no discharge or blowdown, the Agency believes a periodic discharge or bleed stream may be needed to prevent the build-up of dissolved solids in the recycle circuit. Therefore, EPA has provided a discharge allowance equal to 10 percent of the BPT flow for this waste stream.

Lead-Tin-Bismuth Semi-Continuous Ingot Casting Contact Cooling Water. The BAT regulatory flow for this stream is 2.94 l/kg (0.70 gal/ton). The BAT regulatory flow is a 90 percent reduction of the BPT flow, based on recycle through a cooling tower or holding tank. The recycle of casting contact cooling water is demonstrated in the nonferrous metals forming category as well as other point source categories.

Lead-Tin-Bismuth Shot Forming Wet Air Pollution Control Blowdown. The BAT regulatory flow for this stream is 58.8 l/kg (14.07

gal/ton). The BAT regulatory flow is a 90 percent reduction of the BPT flow, based on recycle through a holding tank. The recycle of wet air pollution control wastewater is demonstrated in the nonferrous metals forming category as well as other point source categories.

Lead-Tin-Bismuth Alkaline Cleaning Rinse. The BAT regulatory flow for this stream is 236 l/kg (56.5 gal/ton). The BAT regulatory flow is a 90 percent reduction of the BPT flow, based on the application of countercurrent cascade rinsing with sprays. Although countercurrent cascade rinsing is not used in any of the four alkaline cleaning rinse operations reported for this subcategory this technology is demonstrated at other nonferrous metals forming plants and in other point source categories as well.

Regulated Pollutants

The pollutants considered for regulation under BAT are listed in Section VI, along with an explanation of why they were considered. The pollutants selected for regulation under BAT are antimony and lead. These two pollutants were the only priority pollutants considered for regulation in this subcategory.

Treatment Train

The BAT model end-of-pipe treatment technology for the lead-tin-bismuth forming subcategory is lime and settle. This is the same end-of-pipe technology as BPT, with the addition of measures to reduce the flows from selected waste streams. The end-of-pipe treatment configuration is shown in Figure X-2. The combination of in-process control and end-of-pipe technology increases the removals of pollutants over that achieved by BPT and is demonstrated and technically achievable.

Effluent Limitations

Table VII-21 (page xxxx) presents the treatment effectiveness corresponding to the BAT model treatment train for pollutant parameters considered for regulation in the lead-tin-bismuth forming subcategory. Effluent concentrations (one-day maximum and ten-day average values) are multiplied by the BAT regulatory flows summarized in Table X-24 to calculate the mass of pollutant allowed to be discharged per mass of product. The results of these calculations are shown in Table X-25.

Benefits

In establishing BAT, EPA considered the cost of treatment and control and the pollutant reduction benefits to evaluate economic achievability. As shown in Table X-3, the application of BAT level treatment to the total lead-tin-bismuth forming subcategory will remove approximately 6,520 kg/yr (14,345 lbs/yr) of pollutants including 249 kg/yr (548 lbs/yr) of priority

pollutants. As shown in Table X-13, the application of BAT to direct dischargers only will remove approximately 1,710 kg/yr (3,762 lbs/yr) of pollutants including 49 kg/yr (108 lbs/yr) of priority pollutants. Since there are only three direct discharge plants in this subcategory, total subcategory capital and annual costs and direct discharger capital and annual costs will not be reported in this document in order to protect confidentiality claims. The Agency has determined that the BAT limitations are economically achievable.

MAGNESIUM FORMING SUBCATEGORY

Discharge Flows

Table X-26 lists the BAT regulatory flows for waste streams in the magnesium forming subcategory. All waste streams which received a BPT flow allowance also receive an allowance under BAT. The regulatory flows for three waste streams have been decreased at BAT based on the application of in-process flow reduction control measures. The three flow reduced waste streams are: forging contact cooling water, forging equipment cleaning wastewater, and surface treatment rinse. Calculation of the BAT regulatory flows for these three flow reduced streams is discussed below. The BAT regulatory flows for all other waste streams in the subcategory are equal to the BPT regulatory flows discussed in Section IX.

Magnesium Forging Contact Cooling Water. The BAT regulatory flow for this stream is 289 l/kg (69.3 gal/ton). The BAT regulatory flow is a 90 percent reduction of the BPT flow, based on recycle through a holding tank or cooling tower. Holding tanks are used in place of cooling towers for streams with low flow rates. The recycle of forging contact cooling water is demonstrated in one operation in this subcategory where total recycle of the cooling water with no discharge was reported. Contact cooling water recycle is also demonstrated in other nonferrous forming subcategories as well as other point source categories. Although total recycle with no discharge was reported for one forging operation in this subcategory, the Agency believes that a periodic blowdown or bleed stream of cooling water may be necessary to prevent the build-up of dissolved solids in the recycle circuit. Therefore, EPA has provided a discharge allowance equal to 10 percent of the BPT flow for this waste stream.

Magnesium Forging Equipment Cleaning Wastewater. The BAT regulatory flow for this stream is 3.99 l/kg (0.959 gal/ton). The BAT regulatory flow is a 90 percent reduction of the BPT flow, based on recycle through a holding tank with provision for removal of suspended solids, if necessary, by filtration, gravity settling, or another suspended solids removal step. The recycle of waste-water through holding tanks with suspended solids removal if necessary is demonstrated in the

nonferrous metals forming category as well as other point source categories.

Magnesium Surface Treatment Rinse. The BAT regulatory flow for this stream is 1,890 l/kg (452 gal/ton). The BAT regulatory flow is a 90 percent reduction of the BPT flow, based on the application of countercurrent cascade rinsing. This technology is demonstrated in the nonferrous metals forming category and other point source categories.

Regulated Pollutants

The pollutants considered for regulation under BAT are listed in Section VI, along with an explanation of why they were considered. The only priority pollutants considered for regulate were total chromium and zinc. Total chromium and zinc selected for regulation under BAT along with the nonconventionals pollutants ammonia and fluoride. Although effluent limitations guidelines and standards for magnesium were proposed, no limitations for magnesium were established in the final regulation. This is because regulation of the priority metal pollutants chromium and zinc should ensure that magnesium is removed. The technology required for removal of chromium and zinc (lime and settle) will also remove magnesium.

Treatment Train

The BAT model end-of-pipe treatment technology for the magnesium forming subcategory is lime and settle. This is the same end-of-pipe technology as BPT, with the addition of measures to reduce the flows from selected waste streams. The end-of-pipe treatment configuration is shown in Figure X-2. The combination of in-process control and end-of-pipe technology increases the removals of pollutants over that achieved by BPT and is demonstrated and technically feasible.

Effluent Limitations

Table VII-21 (page xxxx) presents the treatment effectiveness corresponding to the BAT model treatment train for pollutant parameters considered for regulation in the magnesium forming subcategory. Effluent concentrations (one-day maximum and ten-day average values) are multiplied by the BAT regulatory flows summarized in Table X-26 to calculate the mass of pollutant allowed to be discharged per mass of product. The results of these calculations are shown in Table X-27. Although no limitations have been established for magnesium, Table X-27 includes magnesium mass discharge limitations attainable using the BAT model technology. These limitations are presented for the guidance of permit writers. Only daily maximum limitations are presented, based on the detection limit for magnesium (0.10 mg/l), because lime and settle treatment was determined to remove magnesium to below the level of analytical quantification. The attainable monthly average discharge is

expected to be lower than the one-day maximum limitation, but since it would be impossible to monitor for compliance with a lower level, no monthly average has been presented. The limitation table lists all the pollutants which were considered for regulation. Those specifically regulated are marked with an asterisk.

Benefits

In establishing BAT, EPA considered the cost of treatment and control and the pollutant reduction benefits to evaluate economic achievability. As shown in Table X-4, the application of BAT level treatment to the total magnesium forming subcategory will remove approximately 34,100 kg/yr (75,020 lbs/yr) of pollutants including 16,900 kg/yr (37,180 lbs/yr) of priority pollutants. As shown in Table X-1, the corresponding capital and annual costs (1982 dollars) for this removal are \$158,500 and \$99,000 per year, respectively. As shown in Table X-14, the application of BAT to direct dischargers only will remove approximately 29,035 kg/yr (63,880 lbs/yr) of pollutants including 14,800 kg/yr (32,560 lbs/yr) of priority pollutants. As shown in Table X-2, the corresponding capital and annual costs (1982 dollars) for this removal are \$79,400 and \$45,500, respectively. The Agency has determined that the BAT limitations are economically achievable.

NICKEL-COBALT FORMING SUBCATEGORY

Discharge Flows

Table X-28 lists the BAT regulatory flows for waste streams in the nickel-cobalt forming subcategory. All waste streams which received a BPT flow allowance also receive an allowance under BAT. The regulatory flows for eight waste streams have been decreased at BAT based on the application of in-process flow reduction control measures. The eight flow reduced waste streams are: rolling contact cooling water, forging contact cooling water, forging equipment cleaning wastewater, stationary casting contact cooling water, surface treatment rinse, alkaline cleaning rinse, molten salt rinse, and sawing or grinding rinse. Calculation of the BAT regulatory flows for these eight streams is discussed below. The BAT regulatory flows for all other waste streams in the subcategory are equal to the BPT regulatory flows discussed in Section IX.

Nickel-Cobalt Rolling Contact Cooling Water. The BAT regulatory flow for this stream is 75.4 l/kg (18.0 gal/ton). The BAT regulatory flow is a 98 percent reduction of the BPT regulatory flow, based on recycle through a cooling tower or holding tank. Holding tanks are used in place of cooling towers for streams with low flow rates. Ninety-eight percent recycle of rolling contact cooling water is demonstrated in one rolling operation from this subcategory. Total recycle of the contact cooling water with no discharge was reported for two other operations. Although zero discharge was reported for two operations, the

Agency believes a periodic discharge or bleed stream may be needed in order to prevent the build-up of dissolved solids in the recycle circuit. Therefore, EPA has provided a discharge allowance equal to 2 percent of the BPT allowance for this waste stream.

Nickel-Cobalt Forging Contact Cooling Water. The BAT regulatory flow for forging contact cooling water is 24.5 l/kg (5.89 gal/ton). The BAT regulatory flow is a 90 percent reduction of the BPT flow, based on recycle through a cooling tower or holding tank. Recycle of forging contact cooling water is demonstrated by one plant in this subcategory where over 95 percent recycle is achieved (although this plant reported discharging 53.5 l/kg (12.8 gal/ton)). Contact cooling water recycle is also demonstrated at other nonferrous forming plants as well as in other point source categories.

Nickel-Cobalt Forging Equipment Cleaning Wastewater. The BAT regulatory flow for this stream is 4.00 l/kg (0.957 gal/ton). The BAT regulatory flow is a 90 percent reduction of the BPT flow, based on recycle through a holding tank with provision for suspended solids removal, if necessary, by gravity settling, filtration, or another suspended solids removal step. Recycle through holding tanks with suspended solids removal when necessary is demonstrated in the nonferrous metals forming category and other point source categories.

Nickel-Cobalt Stationary Casting Contact Cooling Water. The BAT regulatory flow for this waste stream is 1,210 l/kg (290 gal/ton). The BAT regulatory flow is a 90 percent reduction of the BPT flow, based on recycle through a cooling tower or holding tank. Recycle of stationary casting contact cooling water is demonstrated by one plant in this subcategory where total recycle of the cooling water with no discharge was reported. Casting contact cooling water recycle is also demonstrated at other nonferrous metals forming plants and plants in other categories. Although one plant in this subcategory reported total recycle with no discharge, the Agency believes a periodic discharge or bleed stream may be needed to prevent the build-up of dissolved solids in the recycle loop. Therefore, EPA has provided a discharge allowance equal to 10 percent of the BPT flow for this waste stream.

Nickel-Cobalt Surface Treatment Rinse. The BAT regulatory flow for surface treatment rinse is 2,360 l/kg (565 gal/ton). The BAT regulatory flow is a 90 percent reduction of the BPT flow, based on the application of countercurrent cascade rinsing. Countercurrent cascade rinsing is demonstrated by one plant in this subcategory and plants in other subcategories of this category, as well as plants in other point source categories. Another method for reducing or eliminating the discharge from surface treatment rinses is to recycle the effluent from wastewater treatment to the surface treatment rinse operation. This practice was reported by one plant in the nickel-cobalt forming subcategory. Reuse of surface

treatment rinse for molten salt rinsing was also reported by one plant in this subcategory.

Nickel-Cobalt Alkaline Cleaning Rinse. The BAT regulatory flow for alkaline cleaning rinse is 233 l/kg (55.8 gal/ton). The BAT regulatory flow is a 90 percent reduction of the BPT flow, based on the application of countercurrent cascade rinsing. Another method for reducing or eliminating the discharge of alkaline cleaning rinse is to recycle wastewater treatment effluent to the alkaline cleaning rinse operation. This practice is demonstrated by one plant in the nickel-forming subcategory.

Nickel-Cobalt Molten Salt Rinse. The BAT regulatory flow for molten salt rinse is 844 l/kg (202 gal/ton). The BAT regulatory flow is a 90 percent reduction of the BPT flow, based on the use of periodic batch discharge or decreased flow rate, as demonstrated by three plants currently discharging at less than the BAT regulatory flow.

Nickel-Cobalt Sawing or Grinding Rinse. The BAT regulatory flow for this waste stream is 181 l/kg (43.5 gal/ton). The BAT regulatory flow is a 90 percent reduction of the BPT flow, based on recycle through a holding tank with provision for removal of fines, if necessary, by gravity settling, filtration or another suspended solids removal step. Recycle through holding tanks with provision for suspended solids removal when necessary is demonstrated in this category as well as other point source categories.

Regulated Pollutants

The pollutants considered for regulation under BAT are listed in Section VI, along with an explanation of why they were considered. The pollutants selected for regulation under BAT are total chromium, nickel, and fluoride. The priority metal pollutants cadmium, copper, lead, and zinc, listed in Section VI, are not regulated under BAT. These pollutants are expected to be adequately removed by achievement of the limitations for chromium, nickel, and fluoride.

Treatment Train

The BAT model end-of-pipe treatment technology for the nickel-cobalt forming subcategory is lime settle and filter. This adds filtration to the BPT end-of-pipe technology, and in-process controls to reduce the flows from selected waste streams. The end-of-pipe treatment configuration is shown in Figure X-3. This combination of in-process control and end-of-pipe technology increases the removals of pollutants over that achieved by BPT and is demonstrated and technically feasible.

Effluent Limitations

Table VII-21 (page xxxx) presents the treatment effectiveness corresponding to the BAT model treatment train for pollutant parameters considered for regulation in the nickel-cobalt forming subcategory. Effluent concentrations (one-day maximum and ten-day average values) are multiplied by the BAT regulatory flows summarized in Table X-28 to calculate the mass of pollutant allowed to be discharged per mass of product. The results of these calculations are shown in Table X-29. Although no limitations have been established for cadmium, copper, lead or zinc, Table X-29 includes mass discharge limitations for these pollutants which are attainable using the BAT model technology. The limitation table lists all of the pollutants which were considered for regulation. Those specifically regulated are marked with an asterisk.

Benefits

In establishing BAT, EPA considered the cost of treatment and control and the pollutant reduction benefits to evaluate economic achievability. As shown in Table X-5, the application of BAT level treatment to the total nickel-cobalt forming subcategory will remove approximately 817,000 kg/yr (1,800,000 lbs/yr) of pollutants including 103,500 kg/yr (28,000 lbs/yr) of priority pollutants. As shown in Table X-1, the corresponding capital and annual costs (1982 dollars) for this removal are \$4.115 million and \$2.401 million per year, respectively. As shown in Table X-15, the application of BAT to direct dischargers only will remove approximately 34,800 kg/yr (76,600 lbs/yr) of pollutants including 10,950 kg/yr (24,100 lbs/yr) of priority pollutants. As shown in Table X-2, the corresponding capital and annual costs (1982 dollars) for this removal are \$0.493 million and \$0.242 million per year, respectively. The Agency has determined that the BAT limitations are economically achievable.

PRECIOUS METALS FORMING SUBCATEGORY

Discharge Flows

Table X-30 lists the BAT regulatory flows for waste streams in the precious metals forming subcategory. All waste streams which received a BPT flow allowance also receive an allowance under BAT. The regulatory flows for eight waste streams have been decreased at BAT based on the application of in-process flow reduction control measures. The eight flow reduced waste streams are: direct chill casting contact cooling water, shot casting contact cooling water, semi-continuous and continuous casting contact cooling water, heat treatment contact cooling water, surface treatment rinse, alkaline cleaning rinse, alkaline cleaning prebonding wastewater, and tumbling or burnishing wastewater. Calculation of BAT regulatory flows for these eight flow reduced streams is discussed below. The BAT regulatory flows for all other waste streams in the subcategory are equal to the BPT regulatory flows discussed in Section IX.

Precious Metals Direct Chill Casting Contact Cooling Water. The BAT regulatory flow for this waste stream is 1,080 l/kg (259 gal/ton). The BAT regulatory flow is a 90 percent reduction of the BPT flow, based on recycle through a cooling tower or holding tank. Holding tanks are used in place of cooling towers for streams with low flow rates. Recycle of direct chill casting contact cooling water is demonstrated at one precious metals forming plant where total recycle of the cooling water with no discharge was reported. Casting contact cooling water recycle is demonstrated at other nonferrous metals forming plants as well as at plants in other point source categories. Although total recycle with no discharge was reported by one precious metals forming plant, the Agency believes a periodic discharge or bleed stream may be needed to prevent the build-up of dissolved solids in the recycle circuit. Therefore, EPA has provided a discharge allowance equal to 10 percent of the BPT allowance for this waste stream.

Precious Metals Shot Casting Contact Cooling Water. The BAT regulatory flow for shot casting contact cooling water is 367 l/kg (88.0 gal/ton). The BAT regulatory flow is a 90 percent reduction of the BPT flow, based on recycle through a cooling tower or holding tank. The recycle of casting contact cooling water is thoroughly demonstrated in this category and other point source categories.

Precious Metals Semi-Continuous and Continuous Casting Contact Cooling Water. The BAT regulatory flow for this waste stream is 1,030 l/kg (248 gal/ton). The BAT regulatory flow is a 90 percent reduction of the BPT flow, based on recycle through a cooling tower or holding tank. Recycle of semi-continuous and continuous casting contact cooling water is demonstrated at two plants in the precious metals forming subcategory where total recycle with no discharge of cooling water was reported. Casting contact cooling water recycle is also demonstrated at other nonferrous forming plants and in other point source categories. Although two plants in this subcategory reported total recycle with no discharge of cooling water, EPA believes a periodic blowdown or bleed stream may be needed to prevent the build-up of dissolved solids in the recycle circuit. Therefore, EPA has provided a discharge allowance equal to 10 percent of the BPT flow allowance for this waste stream.

Precious Metals Heat Treatment Contact Cooling Water. The BAT regulatory flow for heat treatment contact cooling water is 417 l/kg (100 gal/ton). The BAT regulatory flow is a 90 percent reduction of the BPT flow, based on recycle through a cooling tower or holding tank. The recycle of contact cooling water is demonstrated in several precious metals forming heat treatment operations. In three operations, total recycle of the cooling water with no discharge of cooling water was reported. Only periodic discharges of contact cooling water were reported for three other operations. Although total recycle of the cooling water was reported for three heat treatment operations, the

Agency believes a periodic blowdown or bleed stream from the recycle circuit may be necessary to prevent the build-up of dissolved solids. Therefore, EPA has provided a discharge allowance equal to 10 percent of the BPT flow allowance for this waste stream.

Precious Metals Surface Treatment Rinse. The BAT regulatory flow for surface treatment rinse is 616 l/kg (148 gal/ton). The BAT regulatory flow is a 90 percent reduction of the BPT flow, based on two-stage countercurrent cascade rinsing. Countercurrent cascade rinsing was reported for two surface treatment rinse operations in this subcategory; a three-stage countercurrent cascade rinse was utilized in one operation while the other operation used a two-stage countercurrent cascade rinse. Although neither countercurrent cascade rinse operation was achieving the BAT regulatory flow, the Agency believes that these operations could achieve the BAT flow if better water use practices such as a lower rinse application rate were used. Three plants in the subcategory currently meet the BAT regulatory flow for surface treatment rinse.

Precious Metals Alkaline Cleaning Rinse. The BAT regulatory flow for alkaline cleaning rinse is 1,120 l/kg (268 gal/ton). The BAT regulatory flow is a 90 percent reduction of the BPT flow, based on the application of two-stage countercurrent cascade rinsing. Countercurrent cascade rinsing is demonstrated in this category and other point source categories.

Precious Metals Alkaline Cleaning Prebonding Wastewater. The BAT regulatory flow for this waste stream is 1,160 l/kg (277 gal/ton). The BAT regulatory flow is a 90 percent reduction of the BPT flow, based on counter flow between stages or recycle of one rinse stage in power scrublines. For small scale, "by-hand" type operations, flow reduction is based on operation of spray or free flowing rinses only during the actual rinsing operation. The BAT regulatory flow is currently achieved by four of the eight reported alkaline cleaning prebonding operations.

Precious Metals Tumbling or Burnishing Wastewater. The BAT regulatory flow for this waste stream is 1,210 l/kg (290 gal/ton). The BAT regulatory flow is a 90 percent reduction of the BPT flow, based on recycle through a holding tank with provision for suspended solids removal, if needed, by gravity settling, filtration or another suspended solids removal step. Recycle of wastewater through holding tanks with provision for suspended solids removal when necessary is demonstrated in this category and other point source categories.

Regulated Pollutants

The pollutants considered for regulation under BAT are listed in Section VI, along with an explanation of why they were considered. The pollutants selected for regulation under BAT are cadmium, copper, lead, silver, and total cyanide. The priority metal pollutants total chromium, nickel, and zinc,

listed in Section VI, are not specifically regulated under BAT. These pollutants are expected to be adequately removed by achievement of the limitations for the regulated pollutants.

Treatment Train

The BAT model end-of-pipe treatment technology for the precious metals forming subcategory is lime and settle. This is the same end-of-pipe technology as BPT, with the addition of measures to reduce the flows from selected waste streams. The end-of-pipe treatment configuration is shown in Figure X-2. This combination of in-process control and end-of-pipe technology increases the removals of pollutants over that achieved by BPT and is demonstrated and technically achievable.

Effluent Limitations

Table VII-21 (page xxxx) presents the treatment effectiveness corresponding to the BAT model treatment train for pollutant parameters considered for regulation in the precious metals forming subcategory. Effluent concentrations (one-day maximum and ten-day average values) are multiplied by the BAT regulatory flows summarized in Table X-30 to calculate the mass of pollutant allowed to be discharged per mass of product. The results of these calculations are shown in Table X-31. Although no limitations have been established for chromium, nickel, or zinc, Table X-31 includes mass discharge limitations for these pollutants which are attainable using the BAT model technology. These limitations are presented for the guidance of permit writers. The limitation table lists all of the pollutants which were considered for regulation. Those specifically regulated are marked with an asterisk.

Benefits

In establishing BAT, EPA considered the cost of treatment and control and the pollutant reduction benefits to evaluate economic achievability. As shown in Table X-6, the application of BAT level treatment to the total precious metals forming subcategory will remove approximately 15,300 kg/yr (33,700 lbs/yr) of pollutants including 213 kg/yr (470 lbs/yr) of priority pollutants. As shown in Table X-1, the corresponding capital and annual costs (1982 dollars) for this removal are \$1.064 million and \$0.452 million per year, respectively. As shown in Table X-16, the application of BAT to direct dischargers only will remove approximately 3,570 kg/yr (7,860 lbs/yr) of pollutants including 42 kg/yr (93 lbs/yr) of priority pollutants. As shown in Table X-2, the corresponding capital and annual costs (1982 dollars) for this removal are \$0.315 million and \$0.128 million per year, respectively. The Agency has determined that the BAT limitations are economically achievable.

REFRACTORY METALS FORMING SUBCATEGORY

Discharge Flows

Table X-32 lists the BAT regulatory flows for waste streams in the refractory metals forming subcategory. All waste streams receiving a BPT flow allowance also receive an allowance under BAT. The regulatory flows for eight waste streams have been decreased at BAT based on the application of in-process flow reduction control measures. These eight waste streams are: forging contact cooling water; surface treatment rinse; alkaline cleaning rinse; molten salt rinse; tumbling, burnishing wastewater; sawing or grinding contact cooling water; sawing or grinding rinse; and equipment cleaning wastewater. Calculation of the BAT regulatory flows for these eight flow reduced streams is discussed below. The BAT regulatory flows for all other waste streams in the subcategory are equal to the BPT regulatory flows discussed in Section IX.

Refractory Metals Forging Contact Cooling Water. The BAT regulatory flow for forging contact cooling water is 32.3 l/kg (7.75 gal/ton). The BAT regulatory flow is a 90 percent reduction of the BPT flow, based on recycle through cooling towers or holding tanks. Holding tanks are used in place of cooling towers for streams with low flow rates. The recycle of contact cooling water is demonstrated in the nonferrous metals forming category and other point source categories.

Refractory Metals Surface Treatment Rinse. The BAT regulatory flow for surface treatment rinse is 12,100 l/kg (2,900 gal/ton). The BAT regulatory flow is a 90 percent reduction of the BPT flow, based on the application of two-stage countercurrent cascade rinsing. Countercurrent cascade rinsing is performed in two surface treatment rinse operations in this subcategory. It is also demonstrated at other nonferrous forming plants and plants in other categories.

Refractory Metals Alkaline Cleaning Rinse. The BAT regulatory flow for this stream is 8,160 l/kg (1,960 gal/ton). The BAT regulatory flow is a 99 percent reduction of the BPT flow, based on the application of three-stage countercurrent cascade rinsing. Three-stage countercurrent rinsing to achieve a 99 percent flow reduction is appropriate for this waste stream because the magnitude of the existing flows for this waste stream reported by plants in this subcategory were more than an order or magnitude larger than flows for similar processes in other subcategories and even for other rinse streams within this subcategory. The BAT regulatory flow based on 99 percent reduction of the BPT flow is within the range of flows established for this process waste stream in other subcategories. Countercurrent cascade rinsing is demonstrated in this subcategory and other nonferrous metals forming subcategories as well as other point source categories.

Refractory Metals Molten Salt Rinse. The BAT regulatory flow for molten salt rinse is 633 l/kkg (152 gal/ton). The BAT regulatory flow is a 90 percent reduction of the BPT flow based on the use of periodic batch discharge or decreased flow rate, as demonstrated by three plants in the nickel-cobalt forming subcategory and one plant in this subcategory.

Refractory Metals Tumbling or Burnishing Wastewater. The BAT regulatory flow for this waste stream is 1,250 l/kkg (300 gal/ton). The BAT regulatory flow is a 90 percent reduction of the BPT flow based on recycle through a holding tank with provision for removal of fines, if needed, by gravity settling, filtration, or another suspended solids removal step. Recycle with suspended solids removal when necessary is demonstrated in the nonferrous metals forming category and other categories.

Refractory Metals Sawing or Grinding Contact Cooling Water. The BAT regulatory flow for this waste stream is 2,430 l/kkg (582 gal/ton). The BAT regulatory flow is a 90 percent reduction of the BPT flow based on recycle through a holding tank with provision for suspended solids removal, if needed, by gravity settling, filtration, or another suspended solids removal step. Sawing or grinding contact cooling water recycle is practiced in four operations from this subcategory. Total recycle of the cooling water with no discharge was reported for three operations, while 80 percent recycle was reported for the fourth operation. Although the production normalized discharge flow from another operation where the cooling water is only periodically discharged was over 10 times lower than the BAT regulatory flow, the Agency believes a periodic discharge or bleed stream is needed to prevent the build-up of dissolved solids in the recycle circuit. Therefore, EPA has provided a discharge allowance equal to 10 percent of the BPT flow for this waste stream.

Refractory Metals Sawing or Grinding Rinse. The BAT regulatory flow for this waste stream is 13.5 l/kkg (3.25 gal/ton). The BAT regulatory flow is a 90 percent reduction of the BPT flow based on recycle through a holding tank with provision for suspended solids removal, if needed by gravity settling, filtration, or another suspended solids removal step. As previously discussed, this technology is demonstrated in this category and other point source categories.

Equipment Cleaning Wastewater. The BAT regulatory flow for equipment cleaning wastewater is 136 l/kkg (32.6 gal/ton). The BAT regulatory flow is a 90 percent reduction of the BPT flow based on recycle through a holding tank with provision for suspended solids removal, if needed by gravity settling, filtration, or another suspended solids removal step. This technology is demonstrated in this category and other categories.

Regulated Pollutants

The pollutants considered for regulation under BAT are listed in Section VI, along with an explanation of why they were considered. The pollutants selected for regulation under BAT are copper, nickel, fluoride, and molybdenum. Although effluent limitations guidelines and standards for columbium, tantalum, tungsten, and vanadium were proposed, no limitations for these pollutants were established in the final regulation. This is because regulation of the priority metal pollutants copper and nickel should ensure that columbium, tantalum, tungsten, and vanadium are removed. The technology required for removal of copper and nickel (lime and settle) will also remove columbium, tantalum, tungsten, and vanadium. The priority metal pollutants total chromium, lead, silver, and zinc, listed in Section VI, are not specifically regulated under BAT. These pollutants are expected to be adequately removed by achievement of the limitations for the regulated pollutants. Molybdenum is specifically regulated under BAT because it will not be adequately removed by the technology (lime and settle) required for the removal of the regulated priority metal pollutants, copper and nickel. The addition of iron to a lime and settle system (iron coprecipitation) is necessary for efficient removal of molybdenum.

Treatment Train

The BAT model end-of-pipe treatment technology for the refractory metals forming subcategory is lime, settle and filter. This adds filtration to the BPT end-of-pipe technology, and in-process controls measures to reduce the flows from selected waste streams. The end-of-pipe treatment configuration is shown in Figure X-3 and includes iron coprecipitation for molybdenum removal. This combination of in-process control and end-of-pipe technology increases the removals of pollutants over that achieved by BPT and is demonstrated and technically feasible.

Effluent Limitations

Table VII-21 (page xxxx) presents the treatment effectiveness corresponding to the BAT model treatment train for pollutant parameters considered for regulation in the refractory metals forming subcategory. Effluent concentrations (one-day maximum and ten-day average values) are multiplied by the BAT regulatory flows summarized in Table X-32 to calculate the mass of pollutant allowed to be discharged per mass of product. The results of these calculations are shown in Table X-33. Although no limitations have been established for columbium, tantalum, tungsten, and vanadium, Table X-33 includes mass discharge limitations for these pollutants which are attainable using the BAT model technology. These limitations are presented for the guidance of permit writers. Only daily maximum limitations are presented for columbium, tantalum, and vanadium, based on the detection limits of 0.12, 0.46, and 0.10 mg/l, respectively. Lime and settle treatment was determined to

remove these pollutants below their level of analytical quantification. The attainable monthly average discharge is expected to be lower than the one-day maximum limitation, but since it would be impossible to monitor for compliance with a lower level, no monthly average has been presented. The limitation table lists all the pollutants which were considered for regulation. Those specifically regulated are marked with an asterisk.

Benefits

In establishing BAT, EPA considered the cost of treatment and control and the pollutant reduction benefits to evaluate economic achievability. As shown in Table X-7, the application of BAT and PSES to the total refractory metals forming subcategory will remove approximately 198,100 kg/yr (435,800 lbs/yr) of pollutants including 326 kg/yr (717 lbs/yr) of priority pollutants. (As discussed in Section XII, EPA has selected Option 2 as the basis for PSES in this subcategory.) As shown in Table X-1, the corresponding capital and annual costs (1982 dollars) for this removal are \$1.572 million and \$0.657 million per year, respectively. As shown in Table X-17, the application of BAT to direct dischargers only will remove approximately 29,350 kg/yr (64,570 lbs/yr) of pollutants including 78 kg/yr (172 lbs/yr) of priority pollutants. As shown in Table X-2, the corresponding capital and annual costs (1982 dollars) for this removal are \$0.135 million and \$0.068 million per year, respectively. The Agency has determined that the BAT limitations are economically achievable.

TITANIUM FORMING SUBCATEGORY

Discharge Flows

Table X-34 lists the BAT regulatory flows for waste streams in the titanium forming subcategory. All waste streams which received an allowance under BPT also receive a BAT flow allowance. The regulatory flows for seven waste streams have been decreased at BAT based on the application of in-process flow reduction control measures. The seven flow reduced waste streams are: rolling contact cooling water; forging contact cooling water; surface treatment rinse; alkaline cleaning rinse-water; tumbling wastewater; sawing or grinding contact cooling water; and wet air pollution control blowdown. Calculation of the BAT regulatory flows for these seven flow reduced streams is discussed below. The BAT regulatory flows for all other waste streams in the subcategory are equal to the BPT regulatory flows discussed in Section IX.

Titanium Rolling Contact Cooling Water. The BAT regulatory flow for rolling contact cooling water is 488 l/kg (117 gal/ton). The BAT regulatory flow is a 90 percent reduction of the BPT flow based on recycle through a holding tank. This technology is demonstrated at nonferrous metals forming plants and plants in other point source categories.

Titanium Forging Contact Cooling Water. The BAT regulatory flow for forging contact cooling water is 99.9 l/kg (24.0 gal/ton). The BAT regulatory flow is a 95 percent reduction of the BPT flow based on recycle through a holding tank with provision for suspended solids removal, if necessary, by gravity settling, filtration, or another suspended solids removal step. Ninety-five percent recycle of forging contact cooling water is demonstrated at one of the four plants in this subcategory which discharge forging contact cooling water.

Titanium Surface Treatment Rinse. The BAT regulatory flow for surface treatment rinse is 2,920 l/kg (700 gal/ton). The BAT regulatory flow is a 90 percent reduction of the BPT flow based on the application of two-stage countercurrent cascade rinsing. Countercurrent cascade rinsing is practiced at nonferrous metals forming plants as well as plants in other point source categories.

Titanium Alkaline Cleaning Rinse. The BAT regulatory flow for alkaline cleaning rinse is 276 l/kg (66.3 gal/ton). The BAT regulatory flow is a 90 percent reduction of the BPT flow based on the application of two-stage countercurrent cascade rinsing. As previously discussed, countercurrent cascade rinsing is a demonstrated technology.

Titanium Tumbling Wastewater. The BAT regulatory flow for tumbling wastewater is 79 l/kg (18.9 gal/ton). The BAT regulatory flow is a 90 percent reduction of the BPT flow based on recycle through a holding tank with provision for removal of suspended solids, if needed, by gravity settling, filtration, or another suspended solids removal step. This technology is demonstrated in the nonferrous metals forming category and other point source categories.

Titanium Sawing or Grinding Contact Cooling Water. The BAT regulatory flow for this stream is 476 l/kg (114 gal/ton). The BAT regulatory flow is a 90 percent reduction of the BPT flow based on recycle through a holding tank with provision for suspended solids removal, if necessary. As previously discussed, the recycle of wastewater through holding tanks with suspended solids removal if necessary is a demonstrated technology.

Titanium Wet Air Pollution Control Blowdown. The BAT regulatory flow for wet air pollution control blowdown is 214 l/kg (51.4 gal/ton). The BAT regulatory flow is a 90 percent reduction of the BPT flow based on recycle through a holding tank. The recycle of wet air pollution control water is demonstrated at five plants in this subcategory which reported 90 percent recycle or greater of the scrubber water.

Regulated Pollutants

The pollutants considered for regulation under BAT are listed in Section VI, along with an explanation of why they were

considered. The pollutants selected for regulation under BAT are lead, zinc, total cyanide, ammonia, and fluoride. The priority metals total chromium, copper, and nickel, listed in Section VI, are not specifically regulated under BAT. Although effluent limitations guidelines and standards for titanium were proposed, no limitations for titanium were established in the final regulation. This is because regulation of the priority metal pollutants lead and zinc should ensure that titanium is removed. The technology required for removal of lead and zinc (lime and settle) will also remove titanium. These pollutants are expected to be adequately removed by achievement of the limitations for the regulated pollutants.

Treatment Train

The BAT model end-of-pipe treatment technology for the titanium forming subcategory is lime and settle. This option uses the same end-of-pipe technology as BPT, with the addition of measures to reduce the flows from selected waste streams. The end-of-pipe treatment configuration is shown in Figure X-2. The combination of in-process control and end-of-pipe technology increases the removals of pollutants over that achieved by BPT and is demonstrated and technically feasible.

Effluent Limitations

Table VII-21 (page xxxx) presents the treatment effectiveness corresponding to the BAT model treatment train for pollutant parameters considered for regulation in the titanium forming subcategory. Effluent concentrations (one-day maximum and ten-day average values) are multiplied by the BAT regulatory flows summarized in Table X-34 to calculate the mass of pollutant allowed to be discharged per mass of product. The results of these calculations are shown in Table X-35. Although no limitations have been established for chromium, copper, nickel, and titanium, Table X-35 includes chromium, copper, nickel, and titanium mass discharge limitations attainable using the BAT model technology. These limitations are presented for the guidance of permit writers. The limitation table lists all the pollutants which were considered for regulation. Those specifically regulated are marked with an asterisk.

Benefits

In establishing BAT, EPA considered the cost of treatment and control and the pollutant reduction benefits to evaluate economic achievability. As shown in Table X-8, the application of BAT level treatment to the total titanium forming subcategory will remove approximately 393,000 kg/yr (864,600 lbs/yr) of pollutants including 644 kg/yr (1,417 lbs/yr) of priority pollutants. As shown in Table X-1, the corresponding capital and annual costs (1982 dollars) for this removal are \$2.881 million and \$2.540 million per year, respectively. As shown in Table X-18, the application of BAT to direct dischargers only will remove

approximately 136,500 kg/yr (300,300 lbs/yr) of pollutants including 259 kg/yr (570 lbs/yr) of priority pollutants. As shown in Table X-2, the corresponding capital and annual costs (1982 dollars) for this removal are \$2.124 million and \$2.192 million per year, respectively. The Agency has determined that the BAT limitations are economically achievable.

URANIUM FORMING SUBCATEGORY

Discharge Flows

Table X-36 lists the BAT regulatory flows for waste streams in the uranium forming subcategory. All waste streams which received a BPT flow allowance also receive an allowance under BAT. The regulatory flows for four waste streams have been decreased at BAT based on the application of in-process flow reduction control measures. The four flow reduced streams are: extrusion tool contact cooling water; heat treatment contact cooling water; sawing or grinding contact cooling water; and laundry washwater. Calculation of the BAT regulatory flows for these four flow reduced streams is discussed below. The BAT regulatory flows for all other waste streams in the subcategory are equal to the BPT regulatory flows discussed in Section IX.

Uranium Extrusion Tool Contact Cooling Water. The BAT regulatory flow for extrusion tool contact cooling water is 34.4 l/kg (8.25 gal/ton). The BAT regulatory flow is a 90 percent reduction of the BPT flow based on recycle through a cooling tower or holding tank. Holding tanks are used in place of cooling towers for streams with low flow rates. The recycle of contact cooling water streams is demonstrated in the nonferrous metals forming category as well as other point source categories.

Uranium Heat Treatment Contact Cooling Water. The BAT regulatory flow for heat treatment contact cooling water is 31.3 l/kg (7.52 gal/ton). The BAT allowance is based on the average production normalized discharge flow from three operations in which the cooling water is only periodically discharged. This incorporates flow reduction by basing the BAT regulatory flow on only those plants that are currently recycling this process waste stream.

Uranium Sawing or Grinding Contact Cooling Water. The BAT regulatory flow for this stream is 165 l/kg (39.5 gal/ton). The BAT regulatory flow is a 90 percent reduction of the BPT flow based on recycle through a cooling tower or holding tank. As previously discussed, the recycle of contact cooling water is a demonstrated technology.

Uranium Laundry Washwater. The BAT regulatory flow for laundry washwater is 26.2 l/employee-day. The BAT regulatory flow is a 50 percent reduction of the BPT flow based on recycle through a holding tank.

Regulated Pollutants

The pollutants considered for regulation under BAT are listed in Section VI, along with an explanation of why they were considered. Although effluent limitations guidelines and standards for uranium and radium were proposed, no limitations for uranium or radium were established in the final regulation. This is because regulation of the priority metal pollutants cadmium, chromium, copper, lead and nickel will ensure that uranium is removed and radium was not present in significant concentrations. The technology required for removal of cadmium, chromium, copper, lead and nickel (lime and settle) will also remove uranium. The pollutants selected for regulation under BAT are cadmium, total chromium, copper, lead, nickel, molybdenum, and fluoride. The priority metal zinc, listed in Section VI, is not regulated under BAT. This pollutant is expected to be adequately removed by achievement of the limitations for the regulated pollutants.

Treatment Train

The BAT model end-of-pipe treatment technology for the uranium forming subcategory is lime settle and filter. This option adds filtration to the BPT end-of-pipe technology, and measures to reduce the flows from selected waste streams. The end-of-pipe treatment configuration is shown in Figure X-3. This combination of in-process control and end-of-pipe technology increases the removals of pollutants over that achieved by BPT and is demonstrated and technically achievable.

Effluent Limitations

Table VII-21 (page xxxx) presents the treatment effectiveness corresponding to the BAT model treatment train for pollutant parameters considered for regulation in the uranium forming subcategory. Effluent concentrations (one-day maximum and ten-day average values) are multiplied by the BAT regulatory flows summarized in Table X-36 to calculate the mass of pollutant allowed to be discharged per mass of product. The results of these calculations are shown in Table X-37. Although no limitations have been established for uranium and zinc, Table X-37 includes uranium and zinc mass discharge limitations attainable using the BAT model technology. These limitations are presented for the guidance of permit writers. The limitation table lists all the pollutants which were considered for regulation. Those specifically regulated are marked with an asterisk.

Benefits

In establishing BAT, EPA considered the cost of treatment and control and the pollutant reduction benefits to evaluate economic achievability. As shown in Table X-9, the application of BAT to the uranium forming subcategory (which consists entirely of direct dischargers) will remove approximately 23,650 kg/yr

(52,140 lbs/yr) of pollutants including 59.45 kg/yr (131.1 lbs/yr) of priority pollutants. Specific costs for the uranium forming subcategory are not included in this document in order to protect confidentiality claims. The Agency has determined that the BAT limitations for the uranium forming subcategory are economically achievable.

ZINC FORMING SUBCATEGORY

Discharge Flows

Table X-38 lists the BAT regulatory flows for waste streams in the zinc forming subcategory. All waste streams receiving a BPT flow allowance also receive an allowance under BAT. The regulatory flows for five waste streams have been decreased at BAT based on the application of in-process flow reduction control measures. The five flow reduced waste streams are: rolling contact cooling water, direct chill casting contact cooling water, annealing heat treatment contact cooling water, surface treatment rinse, and electrocoating rinse. Calculation of the BAT regulatory flows for these five flow reduced waste streams is discussed below. The BAT regulatory flows for all other waste streams in the subcategory are equal to the BPT regulatory flows discussed in Section X.

Zinc Rolling Contact Cooling Water. The BAT regulatory flow for rolling contact cooling water is 53.6 l/kg (12.9 gal/ton). The BAT regulatory flow is a 90 percent reduction of the BPT flow based on recycle through a cooling tower or holding tank. Holding tanks are used in place of cooling towers for streams with low flow rates. The recycle of contact cooling water is demonstrated in this category as well as other point source categories.

Zinc Direct Chill Casting Contact Cooling Water. The BAT regulatory flow for direct chill casting contact cooling water is 50.5 l/kg (12.1 gal/ton). The BAT regulatory flow is a 90 percent reduction of the BPT flow based on recycle through a cooling tower or holding tank. The recycle of direct chill casting contact cooling water is demonstrated by one plant in this subcategory where total recycle of the cooling water with no discharge was reported. Although zero discharge was reported by one plant, the Agency believes a periodic blowdown or bleed stream of cooling water may be needed to prevent the build-up of dissolved solids in the recycle circuit. Therefore, EPA has provided a discharge allowance equal to 10 percent of the BPT allowance for this waste stream.

Zinc Annealing Heat Treatment Contact Cooling Water. The BAT regulatory flow for this waste stream is 76.3 l/kg (18.3 gal/ton). The BAT regulatory flow is a 90 percent reduction of the BPT flow based on recycle through a cooling tower or holding tank. As previously discussed, the recycle of contact cooling water is a demonstrated technology.

Zinc Surface Treatment Rinse. The BAT regulatory flow for surface treatment rinse is 358 l/kg (85.8 gal/ton). The BAT regulatory flow is a 90 percent reduction of the BPT flow based on the application of two-stage countercurrent cascade rinsing. Countercurrent cascade rinsing is demonstrated at one plant in this subcategory, at other plants in this category, and other point source categories.

Zinc Electrocoating Rinse. The BAT regulatory flow for electrocoating rinse is 229 l/kg (55 gal/ton). The BAT regulatory flow is a 90 percent reduction of the BPT flow based on the application of two-stage countercurrent cascade rinsing. Countercurrent cascade rinsing is demonstrated at one plant in this subcategory.

Regulated Pollutants

The pollutants considered for regulation under BAT are listed in Section VI, along with an explanation of why they were considered. The pollutants selected for regulation under BAT are total chromium, copper, zinc, and total cyanide. The priority metal nickel, which was selected for consideration for regulation in Section VI, is not specifically regulated under BAT, because it is expected to be adequately removed by achievement of the limitations for the regulated pollutants. The conventional pollutant parameters oil and grease, total suspended solids, and pH are not regulated under BAT, but will be considered under BCT.

Treatment Train

The BAT model end-of-pipe treatment technology for the zinc forming subcategory is lime, settle and filter. This adds filtration to the BPT end-of-pipe technology, and in-process controls to reduce the flows from selected waste streams. The end-of-pipe treatment configuration is shown in Figure X-3. This combination of in-process control and end-of-pipe technology increases the removals of pollutants over that achieved by BPT and is demonstrated and technically feasible.

Effluent Limitations

Table VII-21 (page xxxx) presents the treatment effectiveness corresponding to the BAT model treatment train for pollutant parameters considered for regulation in the zinc forming subcategory. Effluent concentrations (one-day maximum and ten-day average values) are multiplied by the BAT regulatory flows summarized in Table X-38 to calculate the mass of pollutant allowed to be discharged per mass of product. The results of these calculations are shown in Table X-39. Although no limitations have been established for nickel, Table X-39 includes mass discharge limitations for this pollutant attainable using the BAT model technology. These limitations are presented for the guidance of permit writers. The

limitation table lists all of the pollutants which were considered for regulation, with those specifically regulated marked with an asterisk.

Benefits

In establishing BAT, EPA considered the cost of treatment and control and the pollutant reduction benefits to evaluate economic achievability. As shown in Table X-10, the application of BAT to the total zinc forming subcategory will remove approximately 309,800 kg/yr (681,560 lbs/yr) of pollutants including 262,300 kg/yr (577,060 lbs/yr) of priority pollutants. As shown in Table X-20, the application of BAT to direct dischargers only will remove approximately 308,800 kg/yr (679,360 lbs/yr) of pollutants including 262,230 kg/yr (576,900 lbs/yr) of priority pollutants. Since there is only one direct discharge plant in the zinc forming subcategory, total subcategory capital and annual costs and direct discharger capital and annual costs will not be reported in this document in order to protect confidentiality claims. The Agency has determined that the BAT limitations are economically achievable.

ZIRCONIUM-HAFNIUM FORMING SUBCATEGORY

Discharge Flows

Table X-40 lists the BAT regulatory flows for waste streams in the zirconium-hafnium forming subcategory. All waste streams receiving a flow allowance for BPT also receive an allowance under BAT. The regulatory flows for five waste streams have decreased at BAT based on the application of in-process flow reduction control measures. The five flow reduced waste streams are: heat treatment contact cooling water; surface treatment rinse; alkaline cleaning rinse; molten salt rinse; and sawing or grinding rinse. Calculation of the BAT regulatory flows for these five flow reduced streams is discussed below. The BAT regulatory flows for all other waste streams in the subcategory are equal to the BPT regulatory flows discussed in Section IX.

Zirconium-Hafnium Heat Treatment Contact Cooling Water. The BAT regulatory flow for heat treatment contact cooling water is 34.3 l/kg (8.22 gal/ton). The BAT regulatory flow is a 90 percent reduction of the BPT flow based on recycle through a cooling tower or holding tank. Contact cooling water recycle is a demonstrated technology and is demonstrated in the nonferrous metals forming category as well as other point source categories.

Zirconium-Hafnium Surface Treatment Rinse. The BAT regulatory flow for surface treatment rinse is 888 l/kg (213 gal/ton). The BAT regulatory flow is a 90 percent reduction of the BPT flow based on two-stage countercurrent cascade rinsing. Countercurrent cascade rinsing is demonstrated in the nonferrous metals forming category as well as other point source categories.

Zirconium-Hafnium Alkaline Cleaning Rinse. The BAT regulatory flow for alkaline cleaning rinse is 3,140 l/kg (753 gal/ton). The BAT regulatory flow is a 90 percent reduction of the BPT flow based on the application of two-stage countercurrent cascade rinsing. Countercurrent cascade rinsing is a demonstrated technology, as described above.

Zirconium-Hafnium Molten Salt Rinse. The BAT regulatory flow for molten salt rinse is 756 l/kg (181 gal/ton). The BAT regulatory flow is a 90 percent reduction of the BPT flow based on use of periodic batch discharge or decreased flow rate, as demonstrated by one plant in this subcategory, three plants in the nickel-cobalt forming subcategory and one plant in the refractory metals forming subcategory.

Zirconium-Hafnium Sawing or Grinding Rinse. The BAT regulatory flow for this waste stream is 180 l/kg (43.1 gal/ton). The BAT regulatory flow is a 90 percent reduction of the BPT flow based on recycle through a holding tank with provision for suspended solids removal, if needed, by gravity settling, filtration, or another solids removal process. Recycle of waste streams through holding tanks with suspended solids removal when necessary is a demonstrated technology.

Regulated Pollutants

The pollutants considered for regulation under BAT are listed in Section VI, along with an explanation of why they were considered. The pollutants selected for regulation under BAT are total chromium, nickel, total cyanide, and fluoride. Although effluent limitations guidelines and standards for zirconium and hafnium were proposed, no limitations for these pollutants were established in the final regulation. This is because regulation of the priority metal pollutants chromium and nickel should ensure that zirconium and hafnium are removed. The technology required for removal of chromium and nickel (lime and settle) will also remove zirconium and hafnium. The priority metals copper, lead, and zinc, listed in Section VI, are not regulated under BAT. These pollutants are expected to be adequately removed by achievement of the limitations for the regulated pollutants.

Treatment Train

The BAT model end-of-pipe treatment technology for the zirconium-hafnium subcategory is lime and settle. This uses the same end-of-pipe technology as BPT, with the addition of measures to reduce the flows from selected waste streams. The end-of-pipe treatment configuration is shown in Figure X-2. The combination of in-process control and end-of-pipe technology increases the removals of pollutants over that achieved by BPT and is demonstrated and technically feasible.

Effluent Limitations

Table VII-21 (page xxxx) presents the treatment effectiveness corresponding to the BAT model treatment train for pollutant parameters considered for regulation in the zirconium-hafnium forming subcategory. Effluent concentrations (one-day maximum and ten-day average values) are multiplied by the BAT regulatory flows summarized in Table X-40 to calculate the mass of pollutant allowed to be discharged per mass of product. The results of these calculations are shown in Table X-41. Although no limitations have been established for copper, lead, zinc, zirconium, and hafnium, Table X-41 includes zirconium and hafnium mass discharge limitations attainable using the BAT model technology. These limitations are presented for the guidance of permit writers. The limitation table lists all the pollutants which were considered for regulation. Those specifically regulated are marked with an asterisk.

Benefits

In establishing BAT, EPA considered the cost of treatment and control and the pollutant reduction benefits to evaluate economic achievability. As shown in Table X-11, the application of BAT to the total zirconium-hafnium forming subcategory will remove approximately 20,200 kg/yr (44,440 lbs/yr) of pollutants including 646 kg/yr (1,421 lbs/yr) of priority pollutants. As shown in Table X-1, the corresponding capital and annual costs (1982 dollars) for this removal are \$0.579 million and \$0.404 million per year, respectively. As shown in Table X-21, the application of BAT to direct dischargers only will remove approximately 19,100 kg/yr (42,020 lbs/yr) of pollutants including 645 kg/yr (1,419 lbs/yr) of priority pollutants. As shown in Table X-2, the corresponding capital and annual costs (1982 dollars) for this removal are \$0.568 million and \$0.400 million per year, respectively. The Agency has determined that the BAT limitations are economically achievable.

METAL POWDERS SUBCATEGORY

Discharge Flows

Table X-42 lists the BAT regulatory flows for waste streams in the metal powders subcategory. The BAT regulatory flows for all waste streams are equal to the regulatory flows established at BPT because the technology option selected as the basis for BAT does not include flow reduction above that which was included at BPT as described in Section IX. Calculation of these flows is discussed in Section IX. None of the direct discharge plants in this subcategory have any of the waste streams for which further flow reduction is applicable.

Regulated Pollutants

The pollutants considered for regulation under BAT are listed in Section VI, along with an explanation of why they have been considered. The pollutants selected for regulation under BAT are copper, lead, and total cyanide. Although effluent limitations guidelines and standards for iron and aluminum were proposed, no limitations for these pollutants were established in the final regulation. Regulation of the priority metal pollutants copper and lead will ensure that iron and aluminum are removed. The technology required for removal of copper and lead (lime and settle) will also remove iron and aluminum. The priority metals total chromium, nickel, and zinc, listed in Section VI, are not regulated under BAT. These pollutants are expected to be adequately removed by achievement of the limitations for the regulated pollutants. The conventional pollutant parameters oil and grease, total suspended solids, and pH are not regulated under BAT, but will be considered under BCT.

Treatment Train

The BAT model end-of-pipe treatment technology for the metal powder subcategory is lime and settle. This consists of preliminary treatment, where necessary, followed by combined wastewater treatment consisting of oil skimming and lime and settle. Since this is also the basis for the BPT limitations, the BPT and BAT limitations for the metal powders subcategory are identical.

Effluent Limitations

Table VII-21 (page xxxx) presents the treatment effectiveness corresponding to the BAT model treatment train for pollutant parameters considered for regulation in the metal powders subcategory. Effluent concentrations (one-day maximum and ten-day average values) are multiplied by the BAT regulatory flows summarized in Table X-42 to calculate the mass of pollutant allowed to be discharged per mass of product. The results of these calculations are shown in Table X-43. Although no limitations have been established for chromium, nickel, zinc, iron and aluminum, Table X-43 includes mass discharge limitations for these pollutants attainable using the BAT model technology. These limitations are presented for the guidance of permit writers. The limitation table lists all the pollutants which were considered for regulation. Those specifically regulated are marked with an asterisk.

Benefits

In establishing BAT, EPA considered the cost of treatment and control and the pollutant reduction benefits to evaluate economic achievability. As shown in Table X-12, the application of BAT to the total metal powder subcategory will remove approximately 57,570 kg/yr (126,655 lbs/yr) of pollutants including 1,085 kg/yr

(2,390 lbs/yr) of priority pollutants. As shown in Table X-22, the application of BAT to direct dischargers only will remove approximately 4,105 kg/yr (9,030 lbs/yr) of pollutants including 128 kg/yr (282 lbs/yr) of priority pollutants. Since there are only three direct discharge plants in the metal powders subcategory, total subcategory capital and annual costs and direct discharger capital and annual costs will not be reported in this document in order to protect confidentiality claims. The Agency has determined that the BAT limitations are economically achievable.

Table X-1

CAPITAL AND ANNUAL COST ESTIMATES FOR BAT (PSES) OPTIONS
TOTAL SUBCATEGORY (\$ 1982)

Subcategory	Option 1	Option 2*	Option 3**
Lead-Tin-Bismuth			
Capital	C	C	C
Annual	C	C	C
Magnesium Forming			
Capital	C	C	C
Annual	C	C	C
Nickel-Cobalt Forming			
Capital	3,341,800	3,792,800	4,115,300
Annual	2,077,000	2,228,900	2,401,000
Precious Metals Forming			
Capital	1,012,700	1,063,600	1,175,300
Annual	413,900	451,600	523,700
Refractory Metals Forming			
Capital	1,117,100	1,560,400	1,670,400
Annual	581,700	649,900	764,900
Titanium Forming			
Capital	2,878,600	2,881,400	3,146,500
Annual	2,570,700	2,540,200	2,694,500
Uranium Forming			
Capital	C	C	C
Annual	C	C	C
Zinc Forming			
Capital	C	C	C
Annual	C	C	C
Zirconium-Hafnium Forming			
Capital	366,500	579,000	697,000
Annual	330,100	404,400	464,800
Metal Powders			
Capital	C	C	C
Annual	C	C	C

*Total cost to install Option 2 technology.

**Total cost to install Option 3 technology.

C - Confidential.

Table X-2

CAPITAL AND ANNUAL COST ESTIMATES FOR BAT OPTIONS
DIRECT DISCHARGERS (\$ 1982)

Subcategory	Option 1	Option 2*	Option 3**
Lead-Tin-Bismuth			
Capital	C	C	C
Annual	C	C	C
Magnesium Forming			
Capital	148,200	79,400	84,800
Annual	95,700	45,500	48,200
Nickel-Cobalt Forming			
Capital	392,200	465,600	493,400
Annual	185,700	225,200	242,300
Precious Metals Forming			
Capital	226,100	314,600	351,600
Annual	98,000	127,900	150,800
Refractory Metals Forming			
Capital	87,000	123,500	135,000
Annual	44,300	60,800	67,700
Titanium Forming			
Capital	2,237,900	2,124,500	2,335,100
Annual	2,261,300	2,191,800	2,312,700
Uranium Forming			
Capital	C	C	C
Annual	C	C	C
Zinc Forming			
Capital	C	C	C
Annual	C	C	C
Zirconium-Hafnium Forming			
Capital	359,400	567,700	685,000
Annual	327,300	400,400	460,400
Metal Powders			
Capital	C	C	C
Annual	C	C	C

*Total cost to install Option 2 technology.

**Total cost to install Option 3 technology.

C - Confidential.

Table X-3

NONFERROUS METALS FORMING POLLUTANT REDUCTION BENEFIT ESTIMATES (kg/yr)
 LEAD-TIN-BISMUTH FORMING SUBCATEGORY
 TOTAL SUBCATEGORY

Pollutant	Total Raw Waste	Option 1 Discharged	Option 1 Removed	Option 2 Discharged	Option 2 Removed	Option 3 Discharged	Option 3 Removed
Antimony	10.38	10.38	0.00	5.06	5.32	3.40	6.98
Arsenic	0.19	0.19	0.00	0.19	0.00	0.19	0.00
Beryllium	0.01	0.01	0.00	0.01	0.00	0.01	0.00
Cadmium	0.04	0.04	0.00	0.04	0.00	0.04	0.00
Chromium	32.19	4.03	28.16	0.61	31.59	0.51	31.69
Copper	2.47	2.47	0.00	2.47	0.00	1.95	0.53
Lead	212.91	5.76	207.16	0.87	212.05	0.58	212.33
Nickel	2.24	2.24	0.00	2.24	0.00	1.10	1.14
Zinc	1.29	1.29	0.00	1.29	0.00	1.15	0.13
TOTAL TOXIC METALS	261.72	26.40	235.32	12.77	248.95	8.92	252.80
Cyanide	0.56	0.56	0.00	0.56	0.00	0.56	0.00
TOTAL TOXICS	262.27	26.95	235.32	13.32	248.95	9.47	252.80
Aluminum	1.53	1.53	0.00	1.53	0.00	1.53	0.00
Ammonia	3.27	3.27	0.00	3.27	0.00	3.27	0.00
Cobalt	115.20	2.40	112.81	0.36	114.84	0.25	114.96
Fluoride	11.85	11.85	0.00	11.85	0.00	11.85	0.00
Iron	16.11	13.08	3.03	2.96	13.15	2.02	14.09
Magnesium	311.35	4.80	306.55	0.72	310.62	0.48	310.86
Manganese	1.59	1.59	0.00	1.16	0.44	1.01	0.58
Molybdenum	0.27	0.27	0.00	0.27	0.00	0.27	0.00
Tin	4.73	4.73	0.00	3.32	1.42	2.44	2.30
Titanium	0.67	0.67	0.00	0.67	0.00	0.67	0.00
Vanadium	0.65	0.65	0.00	0.65	0.00	0.65	0.00
TOTAL NONCONVENTIONALS	467.22	44.84	422.39	26.76	440.47	24.44	442.78
TSS	4,113.63	575.51	3,538.12	86.68	4,026.95	18.78	4,094.85
Oil and Grease	1,875.92	344.36	1,531.53	72.24	1,803.68	72.74	1,803.68
TOTAL CONVENTIONALS	5,989.54	919.89	5,069.65	158.92	5,830.63	91.02	5,898.53
TOTAL POLLUTANTS	6,719.04	991.68	5,727.36	199.00	6,520.05	124.93	6,594.11

1796

Table X-4

NONFERROUS METALS FORMING POLLUTANT REDUCTION BENEFIT ESTIMATES (kg/yr)
MAGNESIUM FORMING SUBCATEGORY
TOTAL SUBCATEGORY

Pollutant	Total Raw Waste	Option 1 Discharged	Option 1 Removed	Option 2 Discharged	Option 2 Removed	Option 3 Discharged	Option 3 Removed
Antimony	0.02	0.02	0.00	0.02	0.00	0.02	0.00
Arsenic	0.00	0.00	0.00	0.00	0.00	0.00	0.00
Beryllium	0.20	0.20	0.00	0.20	0.00	0.20	0.00
Cadmium	0.00	0.00	0.00	0.00	0.00	0.00	0.00
Chromium	16,770.18	1.89	16,768.30	0.23	16,769.95	0.19	16,769.99
Copper	0.48	0.48	0.00	0.37	0.11	0.25	0.23
Lead	1.24	1.24	0.00	0.29	0.95	0.21	1.03
Nickel	0.00	0.00	0.00	0.00	0.00	0.00	0.00
Silver	0.04	0.04	0.00	0.04	0.00	0.04	0.00
Zinc	138.47	7.41	131.06	0.92	137.55	0.64	137.83
TOTAL TOXIC METALS	16,910.63	11.27	16,899.35	2.07	16,908.55	1.55	16,909.08
Cyanide	0.11	0.11	0.00	0.11	0.00	0.11	0.00
TOTAL TOXICS	16,910.73	11.38	16,899.35	2.18	16,908.55	1.65	16,909.08
Aluminum	98.28	50.31	47.97	6.23	92.04	4.15	94.13
Ammonia	526.53	526.53	0.00	526.53	0.00	526.53	0.00
Cobalt	2.03	1.12	0.91	0.14	1.89	0.09	1.94
Fluoride	76.24	76.24	0.00	40.36	35.88	40.36	35.88
Iron	5.47	5.47	0.00	1.14	4.32	0.78	4.69
Magnesium	13,490.05	2.25	13,487.81	0.28	13,489.78	0.19	13,489.87
Manganese	2.80	2.80	0.00	0.45	2.35	0.39	2.41
TOTAL NONCONVENTIONALS	14,201.40	664.72	13,536.69	575.13	13,626.27	572.49	13,628.91
TSS	3,009.78	269.51	2,740.27	33.40	2,976.38	7.24	3,002.54
Oil and Grease	616.65	224.59	392.06	27.83	588.82	27.83	588.82
TOTAL CONVENTIONALS	3,626.43	494.10	3,132.33	61.24	3,565.19	35.07	3,591.36
TOTAL POLLUTANTS	34,738.56	1,170.20	33,568.36	638.55	34,100.02	609.22	34,129.35

1797

Table X-5

NONFERROUS METALS FORMING POLLUTANT REDUCTION BENEFIT ESTIMATES (kg/yr)
 NICKEL-COBALT FORMING SUBCATEGORY
 TOTAL SUBCATEGORY

Pollutant	Total Raw Waste	Option 1 Discharged	Option 1 Removed	Option 2 Discharged	Option 2 Removed	Option 3 Discharged	Option 3 Removed
Arsenic	3.43	3.43	0.00	3.43	0.00	3.43	0.00
Cadmium	817.75	191.61	626.14	22.65	795.10	14.05	803.70
Chromium	7,781.79	203.76	7,578.03	24.10	7,757.69	20.07	7,761.72
Copper	5,036.44	1,407.07	3,629.37	166.33	4,870.11	111.86	4,924.58
Lead	177.48	177.48	0.00	31.85	145.63	22.04	155.44
Nickel	89,531.14	1,795.20	87,735.94	212.27	89,318.87	63.10	89,468.04
Thallium	0.15	0.15	0.00	0.15	0.00	0.15	0.00
Zinc	488.62	488.62	0.00	94.63	393.99	66.00	422.62
TOTAL TOXIC METALS	103,836.80	4,267.32	99,569.48	555.41	103,281.39	300.70	103,536.10
Cyanide	0.09	0.09	0.00	0.09	0.00	0.09	0.00
TOTAL TOXICS	103,836.89	4,267.41	99,569.48	555.50	103,281.39	300.79	103,536.10
Aluminum	633.43	633.43	0.00	528.66	104.77	398.79	234.70
Ammonia	4,287.59	4,287.59	0.00	4,287.59	0.00	4,287.59	0.00
Cobalt	9,677.99	121.29	9,556.70	14.36	9,663.63	9.74	9,668.25
Fluoride	144,546.22	35,175.50	109,370.72	4,158.83	140,387.39	4,158.83	140,387.39
Iron	13,293.21	917.59	12,375.62	117.60	13,175.61	80.31	13,212.90
Molybdenum	1,466.64	1,466.64	0.00	421.07	1,045.57	247.40	1,219.24
Titanium	9,139.58	9,139.58	8,754.41	57.37	9,082.21	37.29	9,102.29
Vanadium	360.58	360.58	0.00	348.27	12.31	234.68	125.90
TOTAL NONCONVENTIONALS	183,405.24	43,347.79	140,057.45	9,933.75	173,471.49	9,454.57	173,950.67
TSS	283,049.33	29,105.20	253,944.13	3,441.76	279,607.57	745.60	282,303.73
Oil and Grease	260,089.26	24,191.88	235,897.38	2,868.30	257,220.96	2,868.30	257,220.96
TOTAL CONVENTIONALS	543,138.59	53,297.08	489,841.51	6,310.06	536,828.53	3,613.90	539,524.69
TOTAL POLLUTANTS	830,380.72	100,912.28	729,468.44	16,799.31	813,581.41	13,369.26	817,011.46

1798

Table X-6

NONFERROUS METALS FORMING POLLUTANT REDUCTION BENEFIT ESTIMATES (kg/yr)
 PRECIOUS METALS FORMING SUBCATEGORY
 TOTAL SUBCATEGORY

Pollutant	Total Raw Waste	Option 1 Discharged	Option 1 Removed	Option 2 Discharged	Option 2 Removed	Option 3 Discharged	Option 3 Removed
Antimony	0.07	0.07	0.00	0.07	0.00	0.07	0.00
Arsenic	0.00	0.00	0.00	0.00	0.00	0.00	0.00
Cadmium	30.53	9.40	21.13	1.00	29.53	0.62	29.91
Chromium	2.81	2.81	0.00	1.05	1.77	0.89	1.93
Copper	92.55	64.09	28.46	7.37	85.18	4.95	87.60
Lead	2.15	2.15	0.00	1.43	0.72	1.02	1.14
Nickel	7.00	7.00	0.00	7.00	0.00	2.79	4.20
Selenium	0.00	0.00	0.00	0.00	0.00	0.00	0.00
Silver	4.75	4.75	0.00	1.27	3.48	0.09	4.67
Thallium	0.00	0.00	0.00	0.00	0.00	0.00	0.00
Zinc	29.95	29.95	0.00	4.19	25.76	2.92	27.03
TOTAL TOXIC METALS	169.82	120.22	49.59	23.37	146.44	13.35	156.46
Cyanide	67.38	8.33	59.05	0.89	66.49	0.60	66.79
TOTAL TOXICS	237.20	128.55	108.65	24.26	212.94	13.95	223.25
Aluminum	184.36	184.36	0.00	28.45	155.91	18.93	165.43
Ammonia	20.39	20.39	0.00	20.39	0.00	20.39	0.00
Cobalt	0.11	0.11	0.00	0.11	0.00	0.11	0.00
Fluoride	77.95	77.95	0.00	77.95	0.00	77.95	0.00
Iron	81.72	48.79	32.93	5.21	76.51	3.56	78.16
Magnesium	360.46	11.90	348.56	1.27	359.19	1.27	359.19
Manganese	16.02	16.02	0.00	2.03	13.99	1.78	14.25
Tin	0.03	0.03	0.00	0.03	0.00	0.03	0.00
Titanium	1.53	1.53	0.00	1.53	0.00	1.43	0.11
Vanadium	0.09	0.09	0.00	0.09	0.00	0.09	0.00
TOTAL NONCONVENTIONALS	742.67	361.18	381.49	137.07	605.60	125.54	617.13
TSS	10,689.20	1,427.93	9,261.27	152.42	10,536.78	33.02	10,656.17
Oil and Grease	4,073.62	1,189.94	2,883.68	127.02	3,946.60	127.02	3,946.60
TOTAL CONVENTIONALS	14,762.82	2,617.87	12,144.95	279.44	14,483.38	160.04	14,602.77
TOTAL POLLUTANTS	15,742.69	3,107.61	12,635.08	440.78	15,301.91	299.53	15,443.16

1799

Table X-7

NONFERROUS METALS FORMING POLLUTANT REDUCTION BENEFIT ESTIMATES (kg/yr)
 REFRACTORY METALS FORMING SUBCATEGORY
 TOTAL SUBCATEGORY

Pollutant	Total	Option 1	Option 1	Option 2	Option 2	Option 3	Option 3
	Raw Waste	Discharged	Removed	Discharged	Removed	Discharged	Removed
Arsenic	0.00	0.00	0.00	0.00	0.00	0.00	0.00
Beryllium	0.00	0.00	0.00	0.00	0.00	0.00	0.00
Cadmium	1.95	1.95	0.00	0.95	1.01	0.71	1.24
Chromium	19.78	19.78	0.00	1.83	17.95	1.56	18.22
Copper	11.91	11.91	0.00	8.25	3.66	6.81	5.09
Lead	1.50	1.50	0.00	1.50	0.00	1.38	0.13
Nickel	312.96	258.63	54.33	16.52	296.44	4.91	308.05
Silver	0.00	0.00	0.00	0.00	0.00	0.00	0.00
Thallium	0.00	0.00	0.00	0.00	0.00	0.00	0.00
Zinc	6.10	6.10	0.00	4.66	1.44	3.83	2.27
TOTAL TOXIC METALS	354.21	299.88	54.33	33.71	320.50	19.20	335.01
Cyanide	0.03	0.03	0.00	0.03	0.00	0.03	0.00
TOTAL TOXICS	354.24	299.91	54.33	33.74	320.50	19.23	335.01
Aluminum	745.56	699.25	46.31	50.00	695.56	33.26	712.30
Ammonia	12.22	12.22	0.00	12.22	0.00	12.22	0.00
Cobalt	3.38	3.38	0.00	0.82	2.56	0.60	2.78
Fluoride	6,172.91	5,058.22	1,114.69	323.68	5,849.23	323.68	5,849.23
Iron	452.31	190.01	262.31	9.15	443.16	6.25	446.06
Magnesium	0.00	0.00	0.00	0.00	0.00	0.00	0.00
Manganese	0.00	0.00	0.00	0.00	0.00	0.00	0.00
Refractory Metals	126,545.16	897.92	125,647.24	23.70	126,521.46	16.57	126,528.60
Titanium	122.04	45.05	76.99	1.55	120.49	1.30	120.74
TOTAL NONCONVENTIONALS	134,053.59	6,906.05	127,147.54	421.13	133,632.46	393.88	133,659.71
TSS	64,084.17	7,998.24	56,085.93	267.88	63,816.30	58.04	64,026.13
Oil and Grease	405.92	405.90	0.03	150.23	255.69	150.23	255.69
TOTAL CONVENTIONALS	64,490.10	8,404.14	56,085.95	418.10	64,071.99	208.27	64,281.83
TOTAL POLLUTANTS	198,897.93	15,610.10	183,287.83	872.97	198,024.95	621.38	198,276.55

1800T

Table X-8

NONFERROUS METALS FORMING POLLUTANT REDUCTION BENEFIT ESTIMATES (kg/yr)
 TITANIUM FORMING SUBCATEGORY
 TOTAL SUBCATEGORY

Pollutant	Total Raw Waste	Option 1 Discharged	Option 1 Removed	Option 2 Discharged	Option 2 Removed	Option 3 Discharged	Option 3 Removed
Arsenic	2.02	2.02	0.00	2.02	0.00	2.02	0.00
Cadmium	0.20	0.20	0.00	0.20	0.00	0.20	0.00
Chromium	40.14	40.14	0.00	13.56	26.58	11.30	28.84
Copper	55.00	55.00	0.00	55.00	0.00	52.71	2.29
Lead	427.13	172.69	254.44	19.37	407.76	12.91	414.22
Nickel	9.40	9.40	0.00	9.40	0.00	9.40	0.00
Thallium	0.07	0.07	0.00	0.07	0.00	0.07	0.00
Zinc	262.58	214.16	48.43	53.27	209.31	37.13	225.46
TOTAL TOXIC METALS	796.54	493.68	302.87	152.89	643.66	125.74	670.81
Cyanide	0.77	0.77	0.00	0.77	0.00	0.77	0.00
TOTAL TOXICS	797.32	494.45	302.87	153.66	643.66	126.51	670.81
Aluminum	11,042.37	3,223.61	7,818.76	361.57	10,680.80	240.51	10,801.86
Ammonia	13,441.20	13,441.20	0.00	13,441.20	0.00	13,441.20	0.00
Cobalt	212.28	71.96	140.32	8.07	204.21	5.49	206.79
Fluoride	168,294.83	20,867.13	147,427.70	2,340.55	165,954.28	2,340.55	165,954.28
Iron	50,114.63	590.04	49,524.60	66.18	50,048.45	45.20	50,069.44
Molybdenum	893.48	846.38	47.10	227.60	665.88	151.73	741.75
Tantalum	0.00	0.00	0.00	0.00	0.00	0.00	0.00
Titanium	118,505.32	287.82	118,217.49	32.28	118,473.03	20.98	118,484.33
Tungsten	0.00	0.00	0.00	0.00	0.00	0.00	0.00
Vanadium	2,747.32	1,644.59	1,102.73	227.60	2,519.72	151.73	2,595.59
TOTAL NONCONVENTIONALS	365,251.43	40,972.73	324,278.70	16,705.06	348,546.37	16,397.40	348,854.04
TSS	43,335.39	17,269.35	26,066.04	1,937.01	41,398.38	419.69	42,915.70
Oil and Grease	4,053.06	4,053.06	0.00	1,614.17	2,438.89	1,614.17	2,438.89
TOTAL CONVENTIONALS	47,388.45	21,322.41	26,066.04	3,551.18	43,837.27	2,033.86	45,354.59
TOTAL POLLUTANTS	413,437.20	62,789.59	350,647.61	20,409.90	393,027.30	18,557.77	394,879.43

1801

Table X-9

NONFERROUS METALS FORMING POLLUTANT REDUCTION BENEFIT ESTIMATES (kg/yr)
 URANIUM FORMING SUBCATEGORY
 TOTAL SUBCATEGORY

Pollutant	Total Raw Waste	Option 1 Discharged	Option 1 Removed-	Option 2 Discharged	Option 2 Removed	Option 3 Discharged	Option 3 Removed
Antimony	0.00	0.00	0.00	0.00	0.00	0.00	0.00
Arsenic	0.00	0.00	0.00	0.00	0.00	0.00	0.00
Cadmium	0.67	0.67	0.00	0.17	0.50	0.11	0.57
Chromium	2.82	1.52	1.30	0.18	2.64	0.15	2.67
Copper	3.94	3.94	0.00	1.25	2.69	0.84	3.10
Lead	42.42	2.17	40.25	0.26	42.16	0.17	42.25
Nickel	1.11	1.11	0.00	1.11	0.00	0.47	0.64
Thallium	0.00	0.00	0.00	0.00	0.00	0.00	0.00
Zinc	10.73	5.96	4.77	0.71	10.02	0.50	10.23
TOTAL TOXIC METALS	61.69	15.37	46.32	3.68	58.01	2.24	59.45
Cyanide	0.09	0.09	0.00	0.09	0.00	0.09	0.00
TOTAL TOXICS	61.79	15.47	46.32	3.78	58.01	2.33	59.45
Aluminum	113.16	40.47	72.69	4.82	108.34	3.21	109.95
Ammonia	39.68	39.68	0.00	39.68	0.00	39.68	0.00
Fluoride	96.08	96.08	0.00	31.22	64.86	31.22	64.86
Iron	850.69	7.41	843.29	0.88	849.81	0.60	850.09
Magnesium	144.96	1.81	143.15	0.22	144.74	0.22	144.74
Molybdenum	0.37	0.37	0.00	0.37	0.00	0.37	0.00
Titanium	5.95	3.61	2.34	0.43	5.52	0.28	5.67
Uranium	9,576.13	72.26	9,503.87	8.61	9,567.52	5.68	9,570.45
TOTAL NONCONVENTIONALS	10,827.02	261.68	10,565.34	86.23	10,740.79	81.25	10,745.77
TSS	12,022.92	216.79	11,806.13	25.83	11,997.09	5.60	12,017.33
Oil and Grease	850.82	180.66	670.16	21.53	829.29	21.53	829.29
TOTAL CONVENTIONALS	12,873.74	397.45	12,476.29	47.36	12,826.38	27.13	12,846.62
TOTAL POLLUTANTS	23,762.55	674.60	23,087.95	137.37	23,625.18	110.72	23,651.83

1802

Table X-10

NONFERROUS METALS FORMING POLLUTANT REDUCTION BENEFIT ESTIMATES (kg/yr)
 ZINC FORMING SUBCATEGORY
 TOTAL SUBCATEGORY

Pollutant	Total Raw Waste	Option 1 Discharged	Option 1 Removed	Option 2 Discharged	Option 2 Removed	Option 3 Discharged	Option 3 Removed
Antimony	0.18	0.18	0.00	0.18	0.00	0.18	0.00
Arsenic	0.01	0.01	0.00	0.01	0.00	0.01	0.00
Beryllium	0.00	0.00	0.00	0.00	0.00	0.00	0.00
Cadmium	0.00	0.00	0.00	0.00	0.00	0.00	0.00
Chromium	3,704.82	6.19	3,698.63	4.56	3,700.26	3.82	3,701.00
Copper	211,750.02	41.79	211,708.23	30.55	211,719.47	20.55	211,729.47
Lead	0.17	0.17	0.00	0.17	0.00	0.17	0.00
Nickel	245.57	57.91	187.66	40.48	205.09	12.03	233.54
Zinc	6,275.87	25.73	6,250.14	18.05	6,257.82	12.58	6,263.29
TOTAL TOXIC METALS	221,976.64	131.98	221,844.66	94.00	221,882.64	49.34	221,927.30
Cyanide	40,371.66	5.48	40,366.18	3.82	40,367.84	2.57	40,369.09
TOTAL TOXICS	262,348.30	137.46	262,210.84	97.82	262,250.48	51.91	262,296.39
Aluminum	152.79	152.79	0.00	119.34	33.45	79.86	72.93
Ammonia	73.15	73.15	0.00	73.15	0.00	73.15	0.00
Cobalt	0.74	0.31	0.43	0.10	0.64	0.07	0.67
Fluoride	23,594.08	1,860.96	21,733.12	1,580.10	22,013.98	1,580.10	22,013.98
Iron	122.96	32.08	90.88	22.43	100.53	15.32	107.64
Magnesium	1,104.16	7.82	1,096.34	5.47	1,098.69	3.67	1,100.49
Manganese	0.01	0.01	0.00	0.01	0.00	0.01	0.00
Molybdenum	0.41	0.41	0.00	0.41	0.00	0.41	0.00
Tin	0.46	0.46	0.00	0.46	0.00	0.46	0.00
Titanium	0.03	0.03	0.00	0.03	0.00	0.03	0.00
Vanadium	0.00	0.00	0.00	0.00	0.00	0.00	0.00
TOTAL NONCONVENTIONALS	25,048.79	2,128.02	22,920.77	1,801.50	23,247.29	1,753.08	23,295.71
TSS	19,916.02	939.04	18,976.98	656.43	19,259.59	142.26	19,773.76
Oil and Grease	4,937.46	782.55	4,154.91	547.01	4,390.45	547.01	4,390.45
TOTAL CONVENTIONALS	24,853.48	1,721.59	23,131.89	1,203.44	23,650.04	689.27	24,164.21
TOTAL POLLUTANTS	312,250.57	3,987.07	308,263.50	3,102.76	309,147.81	2,494.25	309,756.31

1803

Table A-11

NON-FERROUS METALS FORMING POLLUTANT REDUCTION BENEFIT ESTIMATES (kg/y)
 CHROMIUM NICKEL FORMING SUBCATEGORY
 TOTAL SUBCATEGORY

Pollutant	Total Raw Waste	Option 1 Discharged	Option 1 Removed	Option 2 Discharged	Option 2 Removed	Option 3 Discharged	Option 3 Removed
Arsenic	0.06	0.06	0.00	0.06	0.00	0.06	0.00
Cadmium	0.00	0.00	0.00	0.00	0.00	0.00	0.00
Chromium	5.80	5.78	0.02	1.06	4.74	0.86	4.92
Copper	4.31	4.31	0.00	4.31	0.00	4.31	0.00
Lead	1.14	1.14	0.00	1.14	0.00	0.99	0.15
Nickel	1.46	1.46	0.00	1.46	0.00	1.41	0.05
Thallium	0.01	0.01	0.00	0.01	0.00	0.01	0.00
Zinc	2.73	2.04	0.69	1.58	1.15	1.56	1.17
TOTAL TOXIC METALS	15.52	14.08	0.71	9.63	5.89	9.23	6.29
Cyanide	0.05	0.05	0.00	0.05	0.00	0.05	0.01
Dichloromethane	590.83	0.00	590.83	0.00	590.83	0.00	590.83
Toluene	49.36	0.00	46.36	0.00	49.36	0.00	49.36
TOTAL TOXICS	655.75	14.86	640.90	9.68	646.08	9.27	646.48
Aluminum	52.79	52.79	0.00	28.19	24.60	18.75	34.04
Ammonia	52.33	52.33	0.00	52.33	0.00	52.33	0.00
Cobalt	0.31	0.31	0.00	0.31	0.00	0.31	0.00
Fluoride	2,422.22	1,232.40	1,189.82	182.45	2,239.76	182.45	2,239.76
Iron	39.86	34.85	5.02	5.16	34.70	3.52	36.34
Molybdenum	0.11	0.11	0.00	0.11	0.00	0.11	0.00
Titanium	0.27	0.27	0.00	0.27	0.00	0.27	0.00
Vanadium	2.78	2.78	0.00	2.78	0.00	2.78	0.00
Zirconium	7,469.65	613.65	6,856.00	90.85	7,378.80	60.52	7,409.12
TOTAL NONCONVENTIONALS	10,040.31	1,989.48	8,050.83	362.44	9,677.86	321.05	9,719.26
TSS	714.08	657.45	56.63	151.00	563.09	32.72	681.37
Oil and Grease	9,441.90	849.93	8,591.97	125.83	9,316.06	125.83	9,316.06
TOTAL CONVENTIONALS	10,155.98	1,507.38	8,648.60	276.83	9,879.15	158.55	9,997.43
TOTAL POLLUTANTS	20,852.04	3,511.72	17,340.32	648.95	20,203.09	488.85	20,363.18

Table X-12

NONFERROUS METALS FORMING POLLUTANT REDUCTION BENEFIT ESTIMATES (kg/yr)
 METAL POWDERS SUBCATEGORY
 TOTAL SUBCATEGORY

Pollutant	Total Raw Waste	Option 1 Discharged	Option 1 Removed	Option 2 Discharged	Option 2 Removed	Option 3 Discharged	Option 3 Removed
Antimony	0.42	0.42	0.00	0.42	0.00	0.42	0.00
Arsenic	0.68	0.68	0.00	0.68	0.00	0.68	0.00
Cadmium	0.00	0.00	0.00	0.00	0.00	0.00	0.00
Chromium	2.10	2.10	0.00	2.10	0.00	2.10	0.00
Copper	932.80	60.20	872.61	22.20	910.61	14.93	917.88
Lead	183.80	12.45	171.35	4.59	179.21	3.06	180.74
Nickel	44.57	44.57	0.00	25.40	19.17	8.42	36.15
Silver	0.00	0.00	0.00	0.00	0.00	0.00	0.00
Thallium	0.00	0.00	0.00	0.00	0.00	0.00	0.00
Zinc	74.59	34.25	40.34	12.63	61.96	8.80	65.79
TOTAL TOXIC METALS	1,238.96	154.67	1,084.29	68.02	1,170.94	38.40	1,200.56
Cyanide	3.13	3.13	0.00	1.96	1.17	1.32	1.81
TOTAL TOXICS	1,242.09	157.80	1,084.29	69.98	1,172.11	39.72	1,202.37
Aluminum	445.40	232.49	212.92	85.72	359.68	57.02	388.38
Ammonia	16.89	16.89	0.00	16.89	0.00	16.89	0.00
Cobalt	0.01	0.01	0.00	0.01	0.00	0.01	0.00
Fluoride	41.91	41.91	0.00	41.91	0.00	41.91	0.00
Iron	1,980.07	42.55	1,937.51	15.69	1,964.38	10.72	1,969.35
Magnesium	79.58	10.38	69.20	3.83	75.75	2.56	77.02
Manganese	0.64	0.64	0.00	0.64	0.00	0.64	0.00
Tin	87.56	87.56	0.00	39.10	48.46	27.17	69.39
Titanium	34.39	20.76	13.63	7.65	26.73	4.98	29.41
Vanadium	0.36	0.36	0.00	0.36	0.00	0.36	0.00
TOTAL NONCONVENTIONALS	2,686.80	453.54	2,233.26	211.81	2,475.00	162.25	2,524.55
TSS	40,568.98	1,245.46	39,323.52	495.24	40,109.74	99.50	40,469.48
Oil and Grease	15,867.35	935.27	14,932.09	280.08	15,587.27	280.08	15,587.27
TOTAL CONVENTIONALS	56,436.33	2,180.72	54,255.61	739.32	55,697.02	379.58	56,056.75
TOTAL POLLUTANTS	60,365.22	2,792.06	57,573.17	1,021.10	59,344.12	581.56	59,783.67

1805

Table X-13

NONFERROUS METALS FORMING POLLUTANT REDUCTION BENEFIT ESTIMATES (kg/yr)
LEAD-TIN-BISMUTH FORMING SUBCATEGORY
DIRECT DISCHARGERS

Pollutant	Total Raw Waste	Option 1 Discharged	Option 1 Removed	Option 2 Discharged	Option 2 Removed	Option 3 Discharged	Option 3 Removed
Antimony	2.50	2.50	0.00	1.71	0.79	1.15	1.35
Arsenic	0.06	0.06	0.00	0.06	0.00	0.06	0.00
Beryllium	0.00	0.00	0.00	0.00	0.00	0.00	0.00
Cadmium	0.01	0.01	0.00	0.01	0.00	0.01	0.00
Chromium	13.19	1.67	11.52	0.21	12.98	0.17	13.02
Copper	0.08	0.08	0.00	0.08	0.00	0.08	0.00
Lead	35.80	2.39	33.41	0.29	35.51	0.20	35.60
Nickel	0.05	0.05	0.00	0.05	0.00	0.05	0.00
Zinc	0.06	0.06	0.00	0.06	0.00	0.06	0.00
TOTAL TOXIC METALS	51.75	6.83	44.93	2.47	49.28	1.78	49.97
Cyanide	0.23	0.23	0.00	0.23	0.00	0.23	0.00
TOTAL TOXICS	51.98	7.06	44.93	2.70	49.28	2.01	49.97
Aluminum	0.01	0.01	0.00	0.01	0.00	0.01	0.00
Ammonia	0.47	0.47	0.00	0.47	0.00	0.47	0.00
Cobalt	17.85	1.00	16.85	0.12	17.73	0.08	17.77
Fluoride	1.70	1.70	0.00	1.70	0.00	1.70	0.00
Iron	1.58	1.58	0.00	1.00	0.58	0.68	0.89
Magnesium	96.99	1.99	95.00	0.24	96.74	0.16	96.82
Manganese	0.64	0.64	0.00	0.39	0.25	0.34	0.30
Molybdenum	0.03	0.03	0.00	0.03	0.00	0.03	0.00
Tin	4.03	4.03	0.00	2.62	1.42	1.74	2.30
Titanium	0.24	0.24	0.00	0.24	0.00	0.24	0.00
Vanadium	0.27	0.27	0.00	0.27	0.00	0.27	0.00
TOTAL NONCONVENTIONALS	123.81	11.96	111.85	7.10	116.71	5.73	118.08
TSS	1,531.12	238.94	1,292.18	29.34	1,501.79	6.36	1,524.77
Oil and Grease	63.91	63.91	0.00	24.45	39.46	24.45	39.46
TOTAL CONVENTIONALS	1,595.03	302.84	1,292.18	53.78	1,541.25	30.80	1,564.23
TOTAL POLLUTANTS	1,770.82	321.86	1,448.96	63.58	1,707.24	38.54	1,732.28

1806

Table X-14

NONFERROUS METALS FORMING POLLUTANT REDUCTION BENEFIT ESTIMATES (kg/yr)
MAGNESIUM FORMING SUBCATEGORY
DIRECT DISCHARGERS

Pollutant	Total Raw Waste	Option 1 Discharged	Option 1 Removed	Option 2 Discharged	Option 2 Removed	Option 3 Discharged	Option 3 Removed
Antimony	0.02	0.02	0.00	0.02	0.00	0.02	0.00
Arsenic	0.00	0.00	0.00	0.00	0.00	0.00	0.00
Beryllium	0.18	0.18	0.00	0.18	0.00	0.18	0.00
Cadmium	0.00	0.00	0.00	0.00	0.00	0.00	0.00
Chromium	14,675.69	1.48	14,674.21	0.18	14,675.51	0.15	14,675.54
Copper	0.00	0.00	0.00	0.00	0.00	0.00	0.00
Lead	1.20	1.20	0.00	0.26	0.95	0.17	1.03
Nickel	0.00	0.00	0.00	0.00	0.00	0.00	0.00
Silver	0.04	0.04	0.00	0.04	0.00	0.04	0.00
Zinc	119.55	5.81	113.74	0.71	118.84	0.49	119.05
TOTAL TOXIC METALS	14,796.67	8.72	14,787.95	1.38	14,795.30	1.05	14,795.63
Cyanide	0.10	0.10	0.00	0.10	0.00	0.10	0.00
TOTAL TOXICS	14,796.77	8.82	14,787.95	1.48	14,795.30	1.15	14,795.63
Aluminum	81.66	39.42	42.24	4.80	76.87	3.19	78.47
Ammonia	410.75	410.75	0.00	410.75	0.00	410.75	0.00
Cobalt	1.29	0.88	0.41	0.11	1.18	0.07	1.21
Fluoride	61.99	61.99	0.00	31.06	30.92	31.06	30.92
Iron	4.44	4.44	0.00	0.88	3.56	0.60	3.84
Magnesium	27,560.00	1.76	27,558.24	0.21	27,559.79	0.14	27,559.86
Manganese	2.59	2.59	0.00	0.34	2.25	0.30	2.29
TOTAL NONCONVENTIONALS	28,122.72	521.83	27,600.89	448.16	27,674.57	446.12	27,676.60
TSS	2,247.54	211.19	2,036.35	25.71	2,221.83	5.57	2,241.97
Oil and Grease	499.48	175.99	323.49	21.42	478.06	21.42	478.06
TOTAL CONVENTIONALS	2,747.02	387.17	2,359.85	47.13	2,699.89	26.99	2,720.03
TOTAL POLLUTANTS	45,666.51	917.83	44,748.69	496.76	45,169.76	474.26	45,192.26

1807

Table X-15

NONFERROUS METALS FORMING POLLUTANT REDUCTION BENEFIT ESTIMATES (kg/yr)
NICKEL-COBALT FORMING SUBCATEGORY
DIRECT DISCHARGERS

Pollutant	Total Raw Waste	Option 1 Discharged	Option 1 Removed	Option 2 Discharged	Option 2 Removed	Option 3 Discharged	Option 3 Removed
Arsenic	0.39	0.39	0.00	0.39	0.00	0.39	0.00
Cadmium	36.10	29.30	6.80	3.28	32.82	2.03	34.07
Chromium	756.70	31.17	725.53	3.50	753.20	2.90	753.80
Copper	913.10	215.40	697.70	24.10	889.00	16.22	896.88
Lead	2.42	2.42	0.00	2.42	0.00	2.42	0.00
Nickel	9,245.50	274.80	8,970.70	30.80	9,214.70	9.15	9,236.35
Thallium	0.01	0.01	0.00	0.01	0.00	0.01	0.00
Zinc	39.05	39.05	0.00	13.70	25.35	9.60	29.45
TOTAL TOXIC METALS	10,993.27	592.54	10,400.73	78.20	10,915.07	42.72	10,950.55
Cyanide	0.02	0.02	0.00	0.02	0.00	0.02	0.00
TOTAL TOXICS	10,993.30	592.57	10,400.73	78.23	10,915.07	42.75	10,950.55
Aluminum	33.34	33.34	0.00	33.34	0.00	33.34	0.00
Ammonia	908.76	908.76	0.00	908.76	0.00	908.76	0.00
Cobalt	1,080.88	18.56	1,062.32	2.10	1,078.78	1.40	1,079.48
Fluoride	7,090.26	5,383.80	1,706.46	603.00	6,487.26	603.00	6,487.26
Iron	1,235.71	75.20	1,160.51	17.06	1,218.65	11.65	1,224.06
Molybdenum	78.37	78.37	0.00	75.30	3.07	16.88	61.49
Titanium	1,111.82	74.25	1,037.57	8.32	1,103.50	5.41	1,106.41
Vanadium	16.47	16.47	0.00	4.16	12.31	4.16	12.31
TOTAL NONCONVENTIONALS	11,555.61	6,588.75	4,966.86	1,652.04	9,903.57	1,584.60	9,971.01
TSS	10,755.90	4,456.00	6,299.90	499.00	10,256.90	108.00	10,647.90
Oil and Grease	3,645.88	3,645.88	0.00	416.00	3,329.88	416.00	3,229.88
TOTAL CONVENTIONALS	14,401.78	8,101.88	6,299.90	915.00	13,486.78	524.00	13,877.78
TOTAL POLLUTANTS	36,950.69	15,283.20	21,667.49	2,645.27	34,305.42	2,151.35	34,799.34

808T

Table X-16

NONFERROUS METALS FORMING POLLUTANT REDUCTION BENEFIT ESTIMATES (kg/yr)
 PRECIOUS METALS FORMING SUBCATEGORY
 DIRECT DISCHARGERS

Pollutant	Total Raw Waste	Option 1 Discharged	Option 1 Removed	Option 2 Discharged	Option 2 Removed	Option 3 Discharged	Option 3 Removed
Antimony	0.00	0.00	0.00	0.00	0.00	0.00	0.00
Arsenic	0.00	0.00	0.00	0.00	0.00	0.00	0.00
Cadmium	6.69	2.53	4.16	0.27	6.42	0.17	6.52
Chromium	0.26	0.26	0.00	0.26	0.00	0.24	0.03
Copper	13.67	13.67	0.00	1.98	11.69	1.33	12.34
Lead	0.32	0.32	0.00	0.32	0.00	0.27	0.04
Nickel	0.78	0.78	0.00	0.78	0.00	0.75	0.03
Selenium	0.00	0.00	0.00	0.00	0.00	0.00	0.00
Silver	1.32	1.32	0.00	0.34	0.98	0.02	1.30
Thallium	0.00	0.00	0.00	0.00	0.00	0.00	0.00
Zinc	5.58	5.58	0.00	1.12	4.45	0.78	4.79
TOTAL TOXIC METALS	28.61	24.46	4.16	5.07	23.54	3.56	25.05
Cyanide	18.83	2.24	16.59	0.24	18.59	0.16	18.67
TOTAL TOXICS	47.44	26.70	20.74	5.31	42.13	3.72	43.72
Aluminum	28.32	28.32	0.00	7.63	20.69	5.08	23.24
Ammonia	5.30	5.30	0.00	5.30	0.00	5.30	0.00
Cobalt	0.01	0.01	0.00	0.01	0.00	0.01	0.00
Fluoride	16.42	16.42	0.00	16.42	0.00	16.42	0.00
Iron	14.51	13.14	1.36	1.40	13.11	0.95	13.55
Magnesium	96.85	3.21	93.65	0.34	96.51	0.34	96.51
Manganese	4.07	4.07	0.00	0.55	3.52	0.48	3.59
Tin	0.00	0.00	0.00	0.00	0.00	0.00	0.00
Titanium	0.22	0.22	0.00	0.22	0.00	0.22	0.00
Vanadium	0.00	0.00	0.00	0.00	0.00	0.00	0.00
TOTAL NONCONVENTIONALS	165.69	70.68	95.01	31.85	133.83	28.79	136.90
TSS	3,113.09	384.71	2,728.38	40.89	3,072.21	8.86	3,104.23
Oil and Grease	351.66	320.59	31.06	34.07	317.59	34.07	317.59
TOTAL CONVENTIONALS	3,464.75	705.31	2,795.44	74.96	3,389.79	42.93	3,421.82
TOTAL POLLUTANTS	3,677.88	802.69	2,875.19	112.12	3,565.76	75.44	3,602.44

6081

Table X-17

NONFERROUS METALS FORMING POLLUTANT REDUCTION BENEFIT ESTIMATES (kg/yr)
REFRACTORY METALS FORMING SUBCATEGORY
DIRECT DISCHARGERS

Pollutant	Total Raw Waste	Option 1 Discharged	Option 1 Removed	Option 2 Discharged	Option 2 Removed	Option 3 Discharged	Option 3 Removed
Arsenic	0.00	0.00	0.00	0.00	0.00	0.00	0.00
Beryllium	0.00	0.00	0.00	0.00	0.00	0.00	0.00
Cadmium	0.58	0.58	0.00	0.35	0.23	0.23	0.34
Chromium	4.71	4.71	0.00	0.61	4.11	0.54	4.17
Copper	3.10	3.10	0.00	2.80	0.30	2.14	0.96
Lead	0.32	0.32	0.00	0.32	0.00	0.32	0.00
Nickel	72.56	72.56	0.00	5.75	66.81	1.71	70.85
Silver	0.00	0.00	0.00	0.00	0.00	0.00	0.00
Thallium	0.00	0.00	0.00	0.00	0.00	0.00	0.00
Zinc	2.87	2.87	0.00	1.71	1.16	1.29	1.58
TOTAL TOXIC METALS	84.14	84.14	0.00	11.55	72.60	6.24	77.90
Cyanide	0.02	0.02	0.00	0.02	0.00	0.02	0.00
TOTAL TOXICS	84.17	84.17	0.00	11.57	72.60	6.27	77.90
Aluminum	186.04	186.04	0.00	17.42	168.62	11.58	174.45
Ammonia	9.10	9.10	0.00	9.10	0.00	9.10	0.00
Cobalt	0.80	0.80	0.00	0.24	0.56	0.17	0.63
Fluoride	1,668.61	1,668.61	0.00	112.74	1,555.87	112.74	1,555.87
Iron	265.73	84.90	180.83	3.19	262.54	2.18	263.55
Magnesium	0.00	0.00	0.00	0.00	0.00	0.00	0.00
Manganese	0.00	0.00	0.00	0.00	0.00	0.00	0.00
Refractory Metals	15,955.27	305.22	15,650.05	6.55	15,948.72	4.57	15,950.70
Titanium	28.51	15.36	13.15	0.41	28.10	0.35	28.16
TOTAL NONCONVENTIONALS	18,114.06	2,270.03	15,844.03	149.64	17,964.42	140.70	17,973.36
TSS	11,310.50	2,931.95	8,378.55	93.30	11,217.20	20.22	11,290.28
Oil and Grease	50.23	50.21	0.03	46.90	3.34	46.90	3.34
TOTAL CONVENTIONALS	11,360.73	2,982.16	8,378.58	140.20	11,220.53	67.11	11,293.62
TOTAL POLLUTANTS	29,558.96	5,336.35	24,222.60	301.41	29,257.55	214.08	29,344.88

Table X-18

NONFERROUS METALS FORMING POLLUTANT REDUCTION BENEFIT ESTIMATES (kg/yr)
TITANIUM FORMING SUBCATEGORY
DIRECT DISCHARGERS

Pollutant	Total Raw Waste	Option 1 Discharged	Option 1 Removed	Option 2 Discharged	Option 2 Removed	Option 3 Discharged	Option 3 Removed
Arsenic	0.03	0.03	0.00	0.03	0.00	0.03	0.00
Cadmium	0.15	0.15	0.00	0.15	0.00	0.15	0.00
Chromium	15.15	15.15	0.00	10.09	5.06	8.40	6.74
Copper	36.58	36.58	0.00	36.58	0.00	36.58	0.00
Lead	217.22	127.81	89.41	14.41	202.81	9.61	207.62
Nickel	1.04	1.04	0.00	1.04	0.00	1.04	0.00
Thallium	0.00	0.00	0.00	0.00	0.00	0.00	0.00
Zinc	90.72	90.72	0.00	39.62	51.10	27.62	63.11
TOTAL TOXIC METALS	360.91	271.50	89.41	101.93	258.98	83.44	277.47
Cyanide	0.16	0.16	0.00	0.16	0.00	0.16	0.00
TOTAL TOXICS	361.07	271.66	89.41	102.09	258.98	83.60	277.47
Aluminum	3,858.44	2,385.78	1,472.66	268.95	3,589.49	178.90	3,679.54
Ammonia	9,898.97	9,898.97	0.00	9,898.97	0.00	9,898.97	0.00
Cobalt	77.80	53.25	24.55	6.00	71.80	4.08	73.72
Fluoride	44,266.07	15,443.64	28,822.43	1,740.97	42,525.10	1,740.97	42,525.10
Iron	16,889.30	436.68	16,452.61	49.23	16,840.07	33.62	16,855.68
Molybdenum	318.99	318.99	0.00	169.29	149.70	112.86	206.13
Tantalum	0.00	0.00	0.00	0.00	0.00	0.00	0.00
Titanium	42,802.41	213.02	42,589.40	24.01	42,778.40	15.61	42,786.81
Tungsten	0.00	0.00	0.00	0.00	0.00	0.00	0.00
Vanadium	1,117.20	1,117.20	0.00	169.29	947.91	112.86	1,004.34
TOTAL NONCONVENTIONALS	119,229.19	29,867.54	89,361.65	12,326.73	106,902.46	12,097.88	107,131.31
TSS	28,793.48	12,780.95	16,012.53	1,440.80	27,352.67	312.17	28,481.30
Oil and Grease	3,181.73	3,181.73	0.00	1,200.67	1,981.06	1,200.67	1,981.06
TOTAL CONVENTIONALS	31,975.21	15,962.67	16,012.53	2,641.47	29,333.73	1,512.84	30,462.36
TOTAL POLLUTANTS	151,565.47	46,101.87	105,463.59	15,070.29	136,495.17	13,694.33	137,871.14

1811

Table X-19

NONFERROUS METALS FORMING POLLUTANT REDUCTION BENEFIT ESTIMATES (kg/yr)
URANIUM FORMING SUBCATEGORY
DIRECT DISCHARGERS

Pollutant	Total Raw Waste	Option 1 Discharged	Option 1 Removed-	Option 2 Discharged	Option 2 Removed	Option 3 Discharged	Option 3 Removed
Antimony	0.00	0.00	0.00	0.00	0.00	0.00	0.00
Arsenic	0.00	0.00	0.00	0.00	0.00	0.00	0.00
Cadmium	0.67	0.67	0.00	0.17	0.50	0.11	0.57
Chromium	2.82	1.52	1.30	0.18	2.64	0.15	2.67
Copper	3.94	3.94	0.00	1.25	2.69	0.84	3.10
Lead	42.42	2.17	40.25	0.26	42.16	0.17	42.25
Nickel	1.11	1.11	0.00	1.11	0.00	0.47	0.64
Thallium	0.00	0.00	0.00	0.00	0.00	0.00	0.00
Zinc	10.73	5.96	4.77	0.71	10.02	0.50	10.23
TOTAL TOXIC METALS	61.69	15.37	46.32	3.68	58.01	2.24	59.45
Cyanide	0.09	0.09	0.00	0.09	0.00	0.09	0.00
TOTAL TOXICS	61.79	15.47	46.32	3.78	58.01	2.33	59.45
Aluminum	113.16	40.47	72.69	4.82	108.34	3.21	109.95
Ammonia	39.68	39.68	0.00	39.68	0.00	39.68	0.00
Fluoride	96.08	96.08	0.00	31.22	64.86	31.22	64.86
Iron	850.69	7.41	843.29	0.88	849.81	0.60	850.09
Magnesium	144.96	1.81	143.15	0.22	144.74	0.22	144.74
Molybdenum	0.37	0.37	0.00	0.37	0.00	0.37	0.00
Titanium	5.95	3.61	2.34	0.43	5.52	0.28	5.67
Uranium	9,576.13	72.26	9,503.87	8.61	9,567.52	5.68	9,570.45
TOTAL NONCONVENTIONALS	10,827.02	261.68	10,565.34	86.23	10,740.79	81.25	10,745.77
TSS	12,022.92	216.79	11,806.13	25.83	11,997.09	5.60	12,017.33
Oil and Grease	850.82	180.66	670.16	21.53	829.29	21.53	829.29
TOTAL CONVENTIONALS	12,873.74	397.45	12,476.29	47.36	12,826.38	27.13	12,846.62
TOTAL POLLUTANTS	23,762.55	674.60	23,087.95	137.37	23,625.18	110.72	23,651.83

Table X-20

NONFERROUS METALS FORMING POLLUTANT REDUCTION BENEFIT ESTIMATES (kg/yr)
ZINC FORMING SUBCATEGORY
DIRECT DISCHARGERS

Pollutant	Total Raw Waste	Option 1 Discharged	Option 1 Removed	Option 2 Discharged	Option 2 Removed	Option 3 Discharged	Option 3 Removed
Antimony	0.00	0.00	0.00	0.00	0.00	0.00	0.00
Arsenic	0.00	0.00	0.00	0.00	0.00	0.00	0.00
Beryllium	0.00	0.00	0.00	0.00	0.00	0.00	0.00
Cadmium	0.00	0.00	0.00	0.00	0.00	0.00	0.00
Chromium	3,704.68	6.05	3,698.63	4.42	3,700.26	3.68	3,701.00
Copper	211,750.00	41.77	211,708.23	30.53	211,719.47	20.53	211,729.47
Lead	0.16	0.16	0.00	0.16	0.00	0.16	0.00
Nickel	238.22	53.29	184.93	38.95	199.27	11.58	226.64
Zinc	6,227.69	23.67	6,204.02	17.37	6,210.32	12.11	6,215.58
TOTAL TOXIC METALS	221,920.75	124.94	221,795.81	91.43	221,829.32	48.06	221,872.69
Cyanide	40,361.87	5.04	40,356.83	3.68	40,358.19	2.47	49,359.40
TOTAL TOXICS	262,282.62	129.98	262,152.64	95.11	262,187.51	50.53	262,232.09
Aluminum	151.36	151.36	0.00	117.91	33.45	78.43	72.93
Ammonia	72.99	72.99	0.00	72.99	0.00	72.99	0.00
Cobalt	0.00	0.00	0.00	0.00	0.00	0.00	0.00
Fluoride	22,777.28	1,044.16	21,733.12	763.30	22,013.98	763.30	22,013.98
Iron	118.17	29.52	88.65	21.58	96.59	14.74	103.43
Magnesium	1,066.64	7.20	1,059.44	5.26	1,061.38	3.53	1,063.11
Manganese	0.01	0.01	0.00	0.01	0.00	0.01	0.00
Molybdenum	0.00	0.00	0.00	0.00	0.00	0.00	0.00
Tin	0.00	0.00	0.00	0.00	0.00	0.00	0.00
Titanium	0.00	0.00	0.00	0.00	0.00	0.00	0.00
Vanadium	0.00	0.00	0.00	0.00	0.00	0.00	0.00
TOTAL NONCONVENTIONALS	24,186.44	1,305.23	22,881.21	981.04	23,205.40	932.99	23,253.45
TSS	19,196.17	864.10	18,332.07	631.70	18,564.47	136.90	19,059.27
Oil and Grease	4,753.57	720.10	4,033.47	526.40	4,227.17	526.40	4,227.17
TOTAL CONVENTIONALS	23,949.74	1,584.20	22,365.54	1,158.10	22,791.64	663.30	23,286.44
TOTAL POLLUTANTS	310,418.81	3,019.42	307,399.39	2,234.26	308,184.55	1,646.83	308,771.98

1813

Table X-21

NONFERROUS METALS FORMING POLLUTANT REDUCTION BENEFIT ESTIMATES (kg/yr)
ZIRCONIUM-HAFNIUM FORMING SUBCATEGORY
DIRECT DISCHARGERS

Pollutant	Total Raw Waste	Option 1 Discharged	Option 1 Removed	Option 2 Discharged	Option 2 Removed	Option 3 Discharged	Option 3 Removed
Arsenic	0.06	0.06	0.00	0.06	0.00	0.06	0.00
Cadmium	0.00	0.00	0.00	0.00	0.00	0.00	0.00
Chromium	5.64	5.64	0.00	1.04	4.60	0.87	4.78
Copper	4.24	4.24	0.00	4.24	0.00	4.24	0.00
Lead	1.14	1.14	0.00	1.14	0.00	0.99	0.15
Nickel	1.37	1.37	0.00	1.37	0.00	1.37	0.00
Thallium	0.01	0.01	0.00	0.01	0.00	0.01	0.00
Zinc	1.52	1.52	0.00	1.52	0.00	1.52	0.00
TOTAL TOXIC METALS	13.98	13.98	0.00	9.38	4.60	9.06	4.93
Cyanide	0.04	0.04	0.00	0.04	0.00	0.04	0.00
Dichloromethane	590.83	0.00	590.83	0.00	590.83	0.00	590.83
Toluene	49.36	0.00	49.36	0.00	49.36	0.00	49.36
TOTAL TOXICS	654.20	14.02	640.18	9.42	644.79	9.09	645.11
Aluminum	51.37	51.37	0.00	27.72	23.65	18.44	32.93
Ammonia	51.92	51.92	0.00	51.92	0.00	51.92	0.00
Cobalt	0.30	0.30	0.00	0.30	0.00	0.30	0.00
Fluoride	2,395.32	1,209.35	1,185.97	179.44	2,215.88	179.44	2,215.88
Iron	38.34	34.20	4.15	5.07	33.27	3.47	34.88
Molybdenum	0.07	0.07	0.00	0.07	0.00	0.07	0.00
Titanium	0.26	0.26	0.00	0.26	0.00	0.26	0.00
Vanadium	2.69	2.69	0.00	2.69	0.00	2.69	0.00
Zirconium	7,376.00	602.17	6,773.82	89.35	7,286.65	59.53	7,316.47
TOTAL NONCONVENTIONALS	9,916.28	1,952.34	7,963.94	356.84	9,599.44	316.12	9,600.16
TSS	638.38	638.38	0.00	148.50	489.88	32.18	606.20
Oil and Grease	8,543.04	834.04	7,709.00	123.75	8,419.28	123.75	8,419.28
TOTAL CONVENTIONALS	9,181.42	1,472.42	7,709.00	272.26	8,909.16	155.93	9,025.49
TOTAL POLLUTANTS	19,751.90	3,438.78	16,313.12	638.51	19,113.39	481.14	19,270.76

1814

Table X-22

NONFERROUS METALS FORMING POLLUTANT REDUCTION BENEFIT ESTIMATES (kg/yr)
METAL POWDERS SUBCATEGORY
DIRECT DISCHARGERS

Pollutant	Total Raw Waste	Option 1 Discharged	Option 1 Removed	Option 2 Discharged	Option 2 Removed	Option 3 Discharged	Option 3 Removed
Antimony	0.04	0.04	0.00	0.04	0.00	0.04	0.00
Arsenic	0.07	0.07	0.00	0.07	0.00	0.07	0.00
Cadmium	0.00	0.00	0.00	0.00	0.00	0.00	0.00
Chromium	0.22	0.22	0.00	0.22	0.00	0.22	0.00
Copper	111.76	5.95	105.80	5.95	105.80	4.00	107.75
Lead	19.31	1.23	18.07	1.23	18.07	0.82	18.48
Nickel	4.68	4.68	0.00	4.68	0.00	2.26	2.42
Silver	0.00	0.00	0.00	0.00	0.00	0.00	0.00
Thallium	0.00	0.00	0.00	0.00	0.00	0.00	0.00
Zinc	7.71	3.39	4.33	3.39	4.33	2.36	5.35
TOTAL TOXIC METALS	143.79	15.58	128.20	15.58	128.20	9.78	134.01
Cyanide	0.00	0.00	0.00	0.00	0.00	0.00	0.00
TOTAL TOXICS	143.79	15.58	128.20	15.58	128.20	9.78	134.01
Aluminum	46.25	22.99	23.27	22.99	23.27	15.29	30.96
Ammonia	1.01	1.01	0.00	1.01	0.00	1.01	0.00
Cobalt	0.00	0.00	0.00	0.00	0.00	0.00	0.00
Fluoride	2.18	2.18	0.00	2.18	0.00	2.18	0.00
Iron	207.31	4.21	203.10	4.21	203.10	2.87	204.43
Magnesium	5.58	1.03	4.55	1.03	4.55	0.69	4.89
Molybdenum	0.07	0.07	0.00	0.07	0.00	0.07	0.00
Tin	9.14	9.14	0.00	9.14	0.00	7.29	1.85
Titanium	3.61	2.05	1.56	2.05	1.56	1.33	2.28
Vanadium	0.04	0.04	0.00	0.04	0.00	0.04	0.00
TOTAL NONCONVENTIONALS	275.18	42.70	232.48	42.70	232.48	30.76	244.42
TSS	3,868.40	123.14	3,745.26	123.14	3,745.26	26.68	3,841.72
Oil and Grease	0.00	0.00	0.00	0.00	0.00	0.00	0.00
TOTAL CONVENTIONALS	3,868.40	123.14	3,745.26	123.14	3,745.26	26.68	3,841.72
TOTAL POLLUTANTS	4,287.36	181.42	4,105.95	181.42	4,105.95	67.22	4,220.15

1815

Table X-23

OPTIONS SELECTED AS THE TECHNOLOGY BASES FOR BAT

Subcategory	BAT
Lead-Tin-Bismuth Forming	Option 2
Magnesium Forming	Option 2
Nickel-Cobalt Forming	Option 3
Precious Metals Forming	Option 2
Refractory Metals Forming	Option 3
Titanium Forming	Option 2
Uranium Forming	Option 3
Zinc Forming	Option 3
Zirconium-Hafnium Forming	Option 2
Metal Powders Forming	Option 1

Option 1 - Flow Normalization, Lime and Settle

Option 2 - Flow Reduction, Lime and Settle

Option 3 - Flow Reduction, Lime and Settle, Multimedia Filtration

Table X-24
 BAT REGULATORY FLOWS FOR THE
 PRODUCTION OPERATIONS - LEAD-TIN-BISMUTH FORMING SUBCATEGORY

Operation	Waste Stream	Normalized BAT Discharge		Production Normalizing Parameter
		l/kg	gal/ton	
Rolling	Spent emulsions	23.4	5.60	Mass of lead-tin-bismuth rolled with emulsions
	Spent soap solutions	43.0	10.3	Mass of lead-tin-bismuth rolled with soap solutions
Drawing	Spent neat oils	0	0	
	Spent emulsions	26.3	6.30	Mass of lead-tin-bismuth drawn with emulsions
	Spent soap solutions	7.46	1.79	Mass of lead-tin-bismuth drawn with soap solutions
Extrusion	Press or solution heat treatment contact cooling water	144	34.6	Mass of lead-tin-bismuth heat treated and subsequently cooled with water
	Press hydraulic fluid leakage	55.0	13.2	Mass of lead-tin-bismuth extruded
Swaging	Spent emulsions	1.77	0.424	Mass of lead-tin-bismuth swaged with emulsions
Casting				
Continuous Strip Casting	Contact cooling water	1.00	0.240	Mass of lead-tin-bismuth cast by the continuous strip method
Semi-Continuous Ingot Casting	Contact cooling water	2.94	0.704	Mass of lead-tin-bismuth ingot cast by the semi-continuous method
Shot Casting	Contact cooling water	37.3	8.95	Mass of lead-tin-bismuth shot cast
Shot-forming	Wet air pollution control blowdown	58.8	14.1	Mass of lead-tin-bismuth shot formed

1817

Table X-24 (Continued)

BAT REGULATORY FLOWS FOR THE
 PRODUCTION OPERATIONS - LEAD-TIN-BISMUTH FORMING SUBCATEGORY

Operation	Waste Stream	Normalized BAT Discharge		Production Normalizing Parameter
		l/kgg	gal/ton	
Alkaline Cleaning	Spent baths	120	28.7	Mass of lead-tin-bismuth alkaline cleaned
	Rinsewater	236	56.5	Mass of lead-tin-bismuth alkaline cleaned
Degreasing	Spent solvents	0	0	

Table X-25

LEAD-TIN-BISMUTH FORMING SUBCATEGORY
BAT EFFLUENT LIMITATIONS

BAT
Lead-Tin-Bismuth Forming
Rolling Spent Emulsions

Pollutant or pollutant property	Maximum for any one day	Maximum for monthly average
mg/off-kg (lb/million off-lbs) of lead-tin-bismuth rolled with emulsions		
*Antimony	.067	.030
*Lead	.010	.005

BAT
Lead-Tin-Bismuth Forming
Rolling Spent Soap Solutions

Pollutant or pollutant property	Maximum for any one day	Maximum for monthly average
mg/off-kg (lb/million off-lbs) of lead-tin-bismuth rolled with soap solutions		
*Antimony	.124	.055
*Lead	.018	.009

BAT
Lead-Tin-Bismuth Forming
Drawing Spent Neat Oils

There shall be no discharge of process wastewater
pollutants.

Table X-25 (Continued)

LEAD-TIN-BISMUTH FORMING SUBCATEGORY
BAT EFFLUENT LIMITATIONS

BAT

Lead-Tin-Bismuth Forming
Drawing Spent Emulsions

Pollutant or pollutant property	Maximum for any one day	Maximum for monthly average
mg/off-kg (lb/million off-lbs) of lead-tin-bismuth drawn with emulsions		
*Antimony	.076	.034
*Lead	.011	.005

BAT

Lead-Tin-Bismuth Forming
Drawing Spent Soap Solutions

Pollutant or pollutant property	Maximum for any one day	Maximum for monthly average
mg/off-kg (lb/million off-lbs) of lead-tin-bismuth drawn with soap solutions		
*Antimony	.021	.010
*Lead	.003	.001

BAT

Lead-Tin-Bismuth Forming
Extrusion Press or Solution Heat Treatment Contact
Cooling Water

Pollutant or pollutant property	Maximum for any one day	Maximum for monthly average
mg/off-kg (lb/million off-lbs) of lead-tin-bismuth heat treated		
*Antimony	.413	.185
*Lead	.061	.029

Table X-25 (Continued)

LEAD-TIN-BISMUTH FORMING SUBCATEGORY
BAT EFFLUENT LIMITATIONS

BAT

Lead-Tin-Bismuth Forming
Extrusion Press Hydraulic Fluid Leakage

Pollutant or pollutant property	Maximum for any one day	Maximum for monthly average
mg/off-kg (lb/million off-lbs) of lead-tin-bismuth extruded		
*Antimony	.158	.070
*Lead	.023	.011

BAT

Lead-Tin-Bismuth Forming
Swaging Spent Emulsions

Pollutant or pollutant property	Maximum for any one day	Maximum for monthly average
mg/off-kg (lb/million off-lbs) of lead-tin-bismuth swaged with emulsions		
*Antimony	.0051	.0023
*Lead	.0008	.0004

BAT

Lead-Tin-Bismuth Forming
Continuous Strip Casting Contact Cooling Water

Pollutant or pollutant property	Maximum for any one day	Maximum for monthly average
mg/off-kg (lb/million off-lbs) of lead-tin-bismuth cast by the continuous strip method		
*Antimony	.0029	.0013
*Lead	.0004	.0002

Table X-25 (Continued)

LEAD-TIN-BISMUTH FORMING SUBCATEGORY
BAT EFFLUENT LIMITATIONS

BAT
Lead-Tin-Bismuth Forming
Semi-Continuous Ingot Casting Contact Cooling Water

Pollutant or pollutant property	Maximum for any one day	Maximum for monthly average
mg/off-kg (lb/million off-lbs) of lead-tin-bismuth ingot cast by the semi-continuous method		
*Antimony	.008	.004
*Lead	.001	.001

BAT
Lead-Tin-Bismuth Forming
Shot Casting Contact Cooling Water

Pollutant or pollutant property	Maximum for any one day	Maximum for monthly average
mg/off-kg (lb/million off-lbs) of lead-tin-bismuth shot cast		
*Antimony	.107	.048
*Lead	.016	.007

BAT
Lead-Tin-Bismuth Forming
Shot-Forming Wet Air Pollution Control Blowdown

Pollutant or pollutant property	Maximum for any one day	Maximum for monthly average
mg/off-kg (lb/million off-lbs) of lead-tin-bismuth shot formed		
*Antimony	.169	.075
*Lead	.025	.012

Table X-25 (Continued)

LEAD-TIN-BISMUTH FORMING SUBCATEGORY
BAT EFFLUENT LIMITATIONS

BAT
Lead-Tin-Bismuth Forming
Alkaline Cleaning Spent Baths

Pollutant or pollutant property	Maximum for any one day	Maximum for monthly average
mg/off-kg (lb/million off-lbs) of lead-tin-bismuth alkaline cleaned		
*Antimony	.345	.154
*Lead	.050	.024

BAT
Lead-Tin-Bismuth Forming
Alkaline Cleaning Rinse

Pollutant or pollutant property	Maximum for any one day	Maximum for monthly average
mg/off-kg (lb/million off-lbs) of lead-tin-bismuth alkaline cleaned		
*Antimony	.678	.302
*Lead	.099	.047

BAT
Lead-Tin-Bismuth Forming
Degreasing Spent Solvents

There shall be no discharge of process wastewater
pollutants.

Table X-26

BAT REGULATORY FLOWS FOR THE
PRODUCTION OPERATIONS - MAGNESIUM FORMING SUBCATEGORY

Operation	Waste Stream	Normalized BAT Discharge		Production Normalizing Parameter
		l/kgg	gal/ton	
Rolling	Spent emulsions	74.6	17.9	Mass of magnesium rolled with emulsions
Forging	Spent lubricants	0	0	
	Contact cooling water	289	69.3	Mass of forged magnesium cooled with water
	Equipment cleaning wastewater	3.99	0.959	Mass of magnesium forged on equipment requiring cleaning with water
Direct Chill Casting	Contact cooling water	3,950	947	Mass of magnesium cast with direct chill methods
Surface Treatment	Spent baths	466	112	Mass of magnesium surface treated
	Rinsewater	1,890	452	Mass of magnesium surface treated
Sawing or Grinding	Spent emulsions	19.5	4.68	Mass of magnesium sawed or ground
Degreasing	Spent solvents	0	0	
Wet Air Pollution Control	Blowdown	619	148	Mass of magnesium sanded and repaired or forged

1824

Table X-27

MAGNESIUM FORMING SUBCATEGORY
BAT EFFLUENT LIMITATIONS

BAT
Magnesium Forming
Rolling Spent Emulsions

Pollutant or pollutant property	Maximum for any one day	Maximum for monthly average
mg/off-kg (lb/million off-lbs) of magnesium rolled with emulsions		
*Chromium	.033	.013
*Zinc	.109	.046
*Ammonia	9.950	4.370
*Fluoride	4.440	1.970
Magnesium	.007	---

BAT
Magnesium Forming
Forging Spent Lubricants

There shall be no discharge of process wastewater
pollutants.

BAT
Magnesium Forming
Forging Contact Cooling Water

Pollutant or pollutant property	Maximum for any one day	Maximum for monthly average
mg/off-kg (lb/million off-lbs) of forged magnesium cooled with water		
*Chromium	.127	.052
*Zinc	.422	.176
*Ammonia	38.500	17.000
*Fluoride	17.200	7.630
Magnesium	.029	---

Table X-27 (Continued)

MAGNESIUM FORMING SUBCATEGORY
BAT EFFLUENT LIMITATIONS

BAT
Magnesium Forming
Forging Equipment Cleaning Wastewater

Pollutant or pollutant property	Maximum for any one day	Maximum for monthly average
mg/off-kg (lb/million off-lbs) of magnesium forged		
*Chromium	.0018	.0007
*Zinc	.0058	.0024
*Ammonia	.5320	.2340
*Fluoride	.2380	.1060
Magnesium	.0004	---

BAT
Magnesium Forming
Direct Chill Casting Contact Cooling Water

Pollutant or pollutant property	Maximum for any one day	Maximum for monthly average
mg/off-kg (lb/million off-lbs) of magnesium cast with direct chill methods		
*Chromium	1.740	.711
*Zinc	5.770	2.410
*Ammonia	527.000	232.000
*Fluoride	235.000	104.000
Magnesium	.395	---

Table X-27 (Continued)

MAGNESIUM FORMING SUBCATEGORY
BAT EFFLUENT LIMITATIONS

BAT
Magnesium Forming
Surface Treatment Spent Baths

Pollutant or pollutant property	Maximum for any one day	Maximum for monthly average
mg/off-kg (lb/million off-lbs) of magnesium surface treated		
*Chromium	.205	.084
*Zinc	.681	.284
*Ammonia	62.100	27.300
*Fluoride	27.700	12.300
Magnesium	.047	---

BAT
Magnesium Forming
Surface Treatment Rinse

Pollutant or pollutant property	Maximum for any one day	Maximum for monthly average
mg/off-kg (lb/million off-lbs) of magnesium surface treated		
*Chromium	.832	.340
*Zinc	2.760	1.150
*Ammonia	252.000	111.000
*Fluoride	113.000	49.900
Magnesium	.189	---

Table X-27 (Continued)

MAGNESIUM FORMING SUBCATEGORY
BAT EFFLUENT LIMITATIONS

BAT
Magnesium Forming
Sawing or Grinding Spent Emulsions

Pollutant or pollutant property	Maximum for any one day	Maximum for monthly average
mg/off-kg (lb/million off-lbs) of magnesium sawed or ground		
*Chromium	.009	.004
*Zinc	.029	.012
*Ammonia	2.600	1.140
*Fluoride	1.160	.515
Magnesium	.002	---

BAT
Magnesium Forming
Degreasing Spent Solvents

There shall be no discharge of process wastewater
pollutants.

BAT
Magnesium Forming
Wet Air Pollution Control Blowdown

Pollutant or pollutant property	Maximum for any one day	Maximum for monthly average
mg/off-kg (lb/million off-lbs) of magnesium formed		
*Chromium	.273	.112
*Zinc	.904	.378
*Ammonia	82.500	36.300
*Fluoride	36.900	16.400
Magnesium	.062	---

Table X-28

BAT REGULATORY FLOWS FOR THE
 PRODUCTION OPERATIONS - NICKEL-COBALT FORMING SUBCATEGORY

Operation	Waste Stream	Normalized BAT Discharge		Production Normalizing Parameter
		l/kgg	gal/ton	
Rolling	Spent neat oils	0	0	
	Spent emulsions	170	40.9	Mass of nickel-cobalt rolled with emulsions
	Contact cooling water	75.4	18.1	Mass of nickel-cobalt rolled with water
Tube Reducing	Spent lubricants	0	0	
Drawing	Spent neat oils	0	0	
	Spent emulsions	95.4	22.9	Mass of nickel-cobalt drawn with emulsions
Extrusion	Spent lubricants	0	0	
	Press or solution heat treatment contact cooling water	83.2	20.0	Mass of nickel-cobalt extruded or heat treated and subsequently cooled with water
	Press hydraulic fluid leakage	232	55.6	Mass of nickel-cobalt extruded
Forging	Spent lubricants	0	0	
	Contact cooling water	47.4	11.4	Mass of forged nickel-cobalt cooled with water
	Equipment cleaning wastewater	4.00	0.957	Mass of nickel-cobalt forged on equipment requiring cleaning with water
	Press hydraulic fluid leakage	187	44.8	Mass of nickel-cobalt forged
Metal Powder Production	Atomization wastewater	2,620	629	Mass of nickel-cobalt metal powder produced by wet atomization
Stationary Casting	Contact cooling water	1,210	290	Mass of nickel-cobalt cast with stationary casting methods

Table X-28 (Continued)

BAT REGULATORY FLOWS FOR THE
PRODUCTION OPERATIONS - NICKEL-COBALT FORMING SUBCATEGORY

Operation	Waste Stream	Normalized BAT Discharge		Production Normalizing Parameter
		l/kgg	gal/ton	
Vacuum Melting	Steam condensate	0	0	
Annealing and Solution Heat Treatment	Contact cooling water	0	0	
Surface Treatment	Spent baths	935	224	Mass of nickel-cobalt surface treated
	Rinsewater	2,360	565	Mass of nickel-cobalt surface treated
Ammonia	Rinse	14.8	3.54	Mass of nickel-cobalt treated with ammonia solution
Alkaline Cleaning	Spent baths	33.9	8.13	Mass of nickel-cobalt alkaline cleaned
	Rinsewater	233	55.9	Mass of nickel-cobalt alkaline cleaned
Molten Salt	Rinsewater	844	202	Mass of nickel-cobalt treated with molten salt
Sawing or Grinding	Spent emulsions	39.4	9.45	Mass of nickel-cobalt sawed or ground with emulsions
	Rinsewater	181	43.5	Mass of sawed or ground

Table X-28 (Continued)

BAT REGULATORY FLOWS FOR THE
 PRODUCTION OPERATIONS - NICKEL-COBALT FORMING SUBCATEGORY

Operation	Waste Stream	Normalized BAT Discharge		Production Normalizing Parameter
		l/kgg	gal/ton	
Steam Cleaning	Condensate	30.1	7.22	Mass of nickel-cobalt steam cleaned
Hydrostatic Tube Testing and Ultrasonic Testing	Wastewater	0	0	
Dye Penetrant Testing	Wastewater	213	50.9	Mass of nickel-cobalt tested with dye penetrant methods
Miscellaneous Wastewater Sources	Various	246	58.4	Mass of nickel-cobalt formed
Degreasing	Spent solvents	0	0	
Wet Air Pollution Control	Blowdown	810	192	Mass of nickel-cobalt formed
Electrocoating	Rinsewater	3,370	807	Mass of nickel-cobalt electro- coated

1831

NICKEL-COBALT FORMING SUBCATEGORY
BAT EFFLUENT LIMITATIONS

BAT
Nickel-Cobalt Forming
Rolling Spent Neat Oils

There shall be no discharge of process wastewater
pollutants.

BAT
Nickel-Cobalt Forming
Rolling Spent Emulsions

Pollutant or pollutant property	Maximum for any one day	Maximum for monthly average
mg/off-kg (lb/million off-lbs) of nickel-cobalt rolled with emulsions		
Cadmium	.034	.014
*Chromium	.063	.026
Copper	.218	.104
Lead	.048	.022
*Nickel	.094	.063
Zinc	.174	.071
*Fluoride	13.100	4.490

BAT
Nickel-Cobalt Forming
Rolling Contact Cooling Water

Pollutant or pollutant property	Maximum for any one day	Maximum for monthly average
mg/off-kg (lb/million off-lbs) of nickel-cobalt rolled with water		
Cadmium	.015	.006
*Chromium	.028	.011
Copper	.097	.046
Lead	.021	.010
*Nickel	.042	.028
Zinc	.077	.032
*Fluoride	4.490	1.990

Table X-29 (Continued)

NICKEL-COBALT FORMING SUBCATEGORY
BAT EFFLUENT LIMITATIONS

BAT
Nickel-Cobalt Forming
Tube Reducing Spent Lubricants

There shall be no discharge of process wastewater pollutants.

BAT
Nickel-Cobalt Forming
Drawing Spent Neat Oils

There shall be no discharge of process wastewater pollutants.

BAT
Nickel-Cobalt Forming
Drawing Spent Emulsions

Pollutant or pollutant property	Maximum for any one day	Maximum for monthly average
mg/off-kg (lb/million off-lbs) of nickel-cobalt drawn with emulsions		
Cadmium	.019	.008
*Chromium	.035	.014
Copper	.122	.058
Lead	.027	.012
*Nickel	.053	.035
Zinc	.097	.040
*Fluoride	5.680	2.520

BAT
Nickel-Cobalt Forming
Extrusion Spent Lubricants

There shall be no discharge of process wastewater pollutants.

Table X-29 (Continued)

NICKEL-COBALT FORMING SUBCATEGORY
BAT EFFLUENT LIMITATIONS

BAT

Nickel-Cobalt Forming

Extrusion Press or Solution Heat Treatment CCW

Pollutant or pollutant property	Maximum for any one day	Maximum for monthly average
mg/off-kg (lb/million off-lbs) of nickel-cobalt heat treated		
Cadmium	.017	.007
*Chromium	.031	.013
Copper	.107	.051
Lead	.023	.011
*Nickel	.046	.031
Zinc	.085	.035
*Fluoride	4.950	2.200

BAT

Nickel-Cobalt Forming

Extrusion Press Hydraulic Fluid Leakage

Pollutant or pollutant property	Maximum for any one day	Maximum for monthly average
mg/off-kg (lb/million off-lbs) of nickel-cobalt extruded		
Cadmium	.046	.019
*Chromium	.086	.035
Copper	.297	.142
Lead	.065	.030
*Nickel	.128	.086
Zinc	.237	.098
*Fluoride	13.800	6.130

BAT

Nickel-Cobalt Forming

Forging Spent Lubricants

There shall be no discharge of process wastewater
pollutants.

Table X-29 (Continued)

NICKEL-COBALT FORMING SUBCATEGORY
BAT EFFLUENT LIMITATIONS

BAT
Nickel-Cobalt Forming
Forging Contact Cooling Water

Pollutant or pollutant property	Maximum for any one day	Maximum for monthly average
mg/off-kg (lb/million off-lbs) of forged nickel-cobalt cooled with water		
Cadmium	.009	.004
*Chromium	.018	.007
Copper	.061	.029
Lead	.013	.006
*Nickel	.026	.018
Zinc	.048	.020
*Fluoride	2.820	1.250

BAT
Nickel-Cobalt Forming
Forging Equipment Cleaning Wastewater

Pollutant or pollutant property	Maximum for any one day	Maximum for monthly average
mg/off-kg (lb/million off-lbs) of nickel-cobalt forged		
Cadmium	.0008	.0003
*Chromium	.0015	.0006
Copper	.0051	.0024
Lead	.0011	.0005
*Nickel	.0022	.0015
Zinc	.0041	.0017
*Fluoride	.2380	.1060

Table X-29 (Continued)

NICKEL-COBALT FORMING SUBCATEGORY
BAT EFFLUENT LIMITATIONS

BAT
Nickel-Cobalt Forming
Forging Press Hydraulic Fluid Leakage

Pollutant or pollutant property	Maximum for any one day	Maximum for monthly average
mg/off-kg (lb/million off-lbs) of nickel-cobalt forged		
Cadmium	.037	.015
*Chromium	.069	.028
Copper	.240	.114
Lead	.052	.024
*Nickel	.103	.069
Zinc	.191	.079
*Fluoride	11.100	4.940

BAT
Nickel-Cobalt Forming
Metal Powder Production Atomization Wastewater

Pollutant or pollutant property	Maximum for any one day	Maximum for monthly average
mg/off-kg (lb/million off-lbs) of nickel-cobalt metal powder atomized		
Cadmium	.524	.210
*Chromium	.970	.393
Copper	3.360	1.600
Lead	.734	.341
*Nickel	1.440	.970
Zinc	2.670	1.100
*Fluoride	156.000	69.200

Table X-29 (Continued)

NICKEL-COBALT FORMING SUBCATEGORY
BAT EFFLUENT LIMITATIONS

BAT
Nickel-Cobalt Forming
Stationary Casting Contact Cooling Water

Pollutant or pollutant property	Maximum for any one day	Maximum for monthly average
mg/off-kg (lb/million off-lbs) of nickel-cobalt cast with stationary casting methods		
Cadmium	.242	.097
*Chromium	.448	.182
Copper	1.550	.738
Lead	.339	.158
*Nickel	.666	.448
Zinc	1.240	.508
*Fluoride	72.000	32.000

BAT
Nickel-Cobalt Forming
Vacuum Melting Steam Condensate

There shall be no allowance for the discharge of
process wastewater pollutants.

BAT
Nickel-Cobalt Forming
Annealing and Solution Heat Treatment Contact Cooling Water

There shall be no allowance for the discharge of
process wastewater pollutants.

Table X-29 (Continued)

NICKEL-COBALT FORMING SUBCATEGORY
BAT EFFLUENT LIMITATIONS

BAT
Nickel-Cobalt Forming
Surface Treatment Spent Baths

Pollutant or pollutant property	Maximum for any one day	Maximum for monthly average
mg/off-kg (lb/million off-lbs) of nickel-cobalt surface treated		
Cadmium	.187	.075
*Chromium	.346	.140
Copper	1.200	.571
Lead	.262	.122
*Nickel	.514	.346
Zinc	.954	.393
*Fluoride	55.700	24.700

BAT
Nickel-Cobalt Forming
Surface Treatment Rinse

Pollutant or pollutant property	Maximum for any one day	Maximum for monthly average
mg/off-kg (lb/million off-lbs) of nickel-cobalt surface treated		
Cadmium	.472	.189
*Chromium	.873	.354
Copper	3.020	1.440
Lead	.661	.307
*Nickel	1.300	.873
Zinc	2.410	.991
*Fluoride	141.000	62.300

Table X-29 (Continued)

NICKEL-COBALT FORMING SUBCATEGORY
BAT EFFLUENT LIMITATIONS

BAT
Nickel-Cobalt Forming
Ammonia Rinse

Pollutant or pollutant property	Maximum for any one day	Maximum for monthly average
mg/off-kg (lb/million off-lbs) of nickel-cobalt treated with ammonia solution		
Cadmium	.003	.001
*Chromium	.005	.002
Copper	.019	.009
Lead	.004	.002
*Nickel	.008	.005
Zinc	.015	.006
*Fluoride	.881	.391

BAT
Nickel-Cobalt Forming
Alkaline Cleaning Spent Baths

Pollutant or pollutant property	Maximum for any one day	Maximum for monthly average
mg/off-kg (lb/million off-lbs) of nickel-cobalt alkaline cleaned		
Cadmium	.007	.003
*Chromium	.013	.005
Copper	.043	.021
Lead	.009	.004
*Nickel	.019	.013
Zinc	.035	.014
*Fluoride	2.020	.895

Table X-29 (Continued)

NICKEL-COBALT FORMING SUBCATEGORY
BAT EFFLUENT LIMITATIONS

BAT
Nickel-Cobalt Forming
Alkaline Cleaning Rinse

Pollutant or pollutant property	Maximum for any one day	Maximum for monthly average
mg/off-kg (lb/million off-lbs) of nickel-cobalt alkaline cleaned		
Cadmium	.047	.019
*Chromium	.086	.035
Copper	.298	.142
Lead	.065	.030
*Nickel	.128	.086
Zinc	.238	.098
*Fluoride	13.900	6.150

BAT
Nickel-Cobalt Forming
Molten Salt Rinse

Pollutant or pollutant property	Maximum for any one day	Maximum for monthly average
mg/off-kg (lb/million off-lbs) of nickel-cobalt treated with molten salt		
Cadmium	.169	.068
*Chromium	.312	.127
Copper	1.080	.515
Lead	.237	.110
*Nickel	.464	.312
Zinc	.861	.355
*Fluoride	50.200	22.300

Table X-29 (Continued)

NICKEL-COBALT FORMING SUBCATEGORY
BAT EFFLUENT LIMITATIONS

BAT
Nickel-Cobalt Forming
Sawing or Grinding Spent Emulsions

Pollutant or pollutant property	Maximum for any one day	Maximum for monthly average
mg/off-kg (lb/million off-lbs) of nickel-cobalt sawed or ground with emulsions		
Cadmium	.008	.003
*Chromium	.015	.006
Copper	.051	.024
Lead	.011	.005
*Nickel	.022	.015
Zinc	.040	.017
*Fluoride	2.350	1.040

BAT
Nickel-Cobalt Forming
Sawing or Grinding Rinse

Pollutant or pollutant property	Maximum for any one day	Maximum for monthly average
mg/off-kg (lb/million off-lbs) of sawed or ground nickel-cobalt rinsed		
Cadmium	.036	.015
*Chromium	.067	.027
Copper	.232	.111
Lead	.051	.024
*Nickel	.100	.067
Zinc	.185	.076
*Fluoride	10.800	4.780

Table X-29 (Continued)

NICKEL-COBALT FORMING SUBCATEGORY
BAT EFFLUENT LIMITATIONS

BAT
Nickel-Cobalt Forming
Steam Cleaning Condensate

Pollutant or pollutant property	Maximum for any one day	Maximum for monthly average
mg/off-kg (lb/million off-lbs) of nickel-cobalt steam cleaned		
Cadmium	.006	.002
*Chromium	.011	.005
Copper	.039	.018
Lead	.008	.004
*Nickel	.017	.011
Zinc	.031	.013
*Fluoride	1.790	.795

BAT
Nickel-Cobalt Forming
Hydrostatic Tube Testing and Ultrasonic Testing Wastewater

There shall be no allowance for the discharge of
process wastewater pollutants.

BAT
Nickel-Cobalt Forming
Dye Penetrant Testing Wastewater

Pollutant or pollutant property	Maximum for any one day	Maximum for monthly average
mg/off-kg (lb/million off-lbs) of nickel-cobalt tested with dye penetrant methods		
Cadmium	.043	.017
*Chromium	.079	.032
Copper	.273	.130
Lead	.060	.028
*Nickel	.117	.079
Zinc	.217	.090
*Fluoride	12.700	5.630

Table X-29 (Continued)

NICKEL-COBALT FORMING SUBCATEGORY
BAT EFFLUENT LIMITATIONS

BAT
Nickel-Cobalt Forming
Miscellaneous Wastewater Sources

Pollutant or pollutant property	Maximum for any one day	Maximum for monthly average
mg/off-kg (lb/million off-lbs) of nickel-cobalt formed		
Cadmium	.049	.020
*Chromium	.091	.037
Copper	.315	.150
Lead	.069	.032
*Nickel	.136	.091
Zinc	.251	.104
*Fluoride	14.700	6.500

BAT
Nickel-Cobalt Forming
Degreasing Spent Solvents

There shall be no discharge of process wastewater
pollutants.

BAT
Nickel-Cobalt Forming
Wet Air Pollution Control Blowdown

Pollutant or pollutant property	Maximum for any one day	Maximum for monthly average
mg/off-kg (lb/million off-lbs) of nickel-cobalt formed		
Cadmium	.162	.065
*Chromium	.300	.122
Copper	1.040	.494
Lead	.227	.106
*Nickel	.446	.300
Zinc	.826	.340
*Fluoride	48.200	21.400

Table X-29 (Continued)

NICKEL-COBALT FORMING SUBCATEGORY
BAT EFFLUENT LIMITATIONS

BAT
Nickel-Cobalt Forming
Electrocoating Rinse

Pollutant or pollutant property	Maximum for any one day	Maximum for monthly average
mg/off-kg (lb/million off-lbs) of nickel-cobalt electrocoated		
Cadmium	.674	.270
*Chromium	1.250	.506
Copper	4.320	2.060
Lead	.944	.438
*Nickel	1.860	1.250
Zinc	3.440	1.420
*Fluoride	201.000	89.000

Table X-30

BAT REGULATORY FLOWS FOR THE
PRODUCTION OPERATIONS - PRECIOUS METALS FORMING SUBCATEGORY

Operation	Waste Stream	Normalized BAT Discharge		Production Normalizing Parameter
		l/kg	gal/ton	
Rolling	Spent neat oils	0	0	
	Spent emulsions	77.1	18.5	Mass of precious metals rolled with emulsions
Drawing	Spent neat oils	0	0	
	Spent emulsions	47.5	11.4	Mass of precious metals drawn with emulsions
	Spent soap solutions	3.12	0.748	Mass of precious metals drawn with soap solutions
Metal Powder Production	Atomization wastewater	6,680	1,600	Mass of precious metals powder produced by wet atomization
Casting				
Direct Chill Casting	Contact cooling water	1,080	259	Mass of precious metals cast by the direct chill method
Shot Casting	Contact cooling water	367	88.0	Mass of precious metals shot cast
Stationary Casting	Contact cooling water	0	0	
Semi-Continuous and Continuous Casting	Contact cooling water	1,030	248	Mass of precious metals cast by the semi-continuous or continuous method
Heat Treatment	Contact cooling water	417	100	Mass of extruded precious metals heat treated
Surface Treatment	Spent baths	96.3	23.1	Mass of precious metals surface treated
	Rinsewater	616	148	Mass of precious metals surface treated
Alkaline Cleaning	Spent baths	60.0	14.4	Mass of precious metals alkaline cleaned

Table X-30 (Continued)
 BAT REGULATORY FLOWS FOR THE
 PRODUCTION OPERATIONS - PRECIOUS METALS FORMING SUBCATEGORY

Operation	Waste Stream	Normalized BAT Discharge		Production Normalizing Parameter
		l/kg	gal/ton	
Alkaline Cleaning	Rinsewater	1,120	269	Mass of precious metals alkaline cleaned
	Prebonding wastewater	1,160	277	Mass of precious metal and base metal cleaned prior to bonding
Tumbling or Burnishing	Wastewater	1,210	291	Mass of precious metals tumbled or burnished with water-based media
Sawing or Grinding	Spent neat oils	0	0	
	Spent emulsions	93.4	22.4	Mass of precious metals sawed or ground with emulsions
Pressure Bonding	Contact cooling water	83.5	20.0	Mass of precious metal and base metal pressure bonded and subsequently cooled with water
Degreasing	Spent solvents	0	0	
Wet Air Pollution Control	Blowdown	0	0	

Table X-31

PRECIOUS METALS FORMING SUBCATEGORY
BAT EFFLUENT LIMITATIONS

BAT
Precious Metals Forming
Rolling Spent Neat Oils

There shall be no discharge of process wastewater pollutants.

BAT
Precious Metals Forming
Rolling Spent Emulsions

Pollutant or pollutant property	Maximum for any one day	Maximum for monthly average
mg/off-kg (lb/million off-lbs) of precious metals rolled with emulsions		
*Cadmium	.026	.012
Chromium	.034	.014
*Copper	.147	.077
*Cyanide	.022	.009
*Lead	.032	.015
Nickel	.148	.098
*Silver	.032	.013
Zinc	.113	.047

BAT
Precious Metals Forming
Drawing Spent Neat Oils

There shall be no discharge of process wastewater pollutants.

Table X-31 (Continued)

PRECIOUS METALS FORMING SUBCATEGORY
BAT EFFLUENT LIMITATIONS

BAT
Precious Metals Forming
Drawing Spent Emulsions

Pollutant or pollutant property	Maximum for any one day	Maximum for monthly average
mg/off-kg (lb/million off-lbs) of precious metals drawn with emulsions		
*Cadmium	.016	.007
Chromium	.021	.009
*Copper	.090	.048
*Cyanide	.014	.006
*Lead	.020	.010
Nickel	.091	.060
*Silver	.020	.008
Zinc	.069	.029

BAT
Precious Metals Forming
Drawing Spent Soap Solutions

Pollutant or pollutant property	Maximum for any one day	Maximum for monthly average
mg/off-kg (lb/million off-lbs) of precious metals drawn with soap solutions		
*Cadmium	.0011	.0005
Chromium	.0014	.0006
*Copper	.0059	.0031
*Cyanide	.0009	.0004
*Lead	.0013	.0006
Nickel	.0060	.0040
*Silver	.0013	.0005
Zinc	.0046	.0019

Table X-31 (Continued)

PRECIOUS METALS FORMING SUBCATEGORY
BAT EFFLUENT LIMITATIONS

BAT
Precious Metals Forming
Metal Powder Production Atomization Wastewater

Pollutant or pollutant property	Maximum for any one day	Maximum for monthly average
mg/off-kg (lb/million off-lbs) of precious metals powder wet atomized		
*Cadmium	2.270	1.000
Chromium	2.940	1.200
*Copper	12.700	6.680
*Cyanide	1.940	.802
*Lead	2.810	1.340
Nickel	12.800	8.490
*Silver	2.740	1.140
Zinc	9.750	4.080

BAT
Precious Metals Forming
Direct Chill Casting Contact Cooling Water

Pollutant or pollutant property	Maximum for any one day	Maximum for monthly average
mg/off-kg (lb/million off-lbs) of precious metals cast by the direct chill method		
*Cadmium	.367	.162
Chromium	.475	.195
*Copper	2.050	1.080
*Cyanide	.313	.130
*Lead	.454	.216
Nickel	2.080	1.370
*Silver	.443	.184
Zinc	1.580	.659

Table X-31 (Continued)

PRECIOUS METALS FORMING SUBCATEGORY
BAT EFFLUENT LIMITATIONS

BAT
Precious Metals Forming
Shot Casting Contact Cooling Water

Pollutant or pollutant property	Maximum for any one day	Maximum for monthly average
mg/off-kg (lb/million off-lbs) of precious metals shot cast		
*Cadmium	.125	.055
Chromium	.162	.066
*Copper	.698	.367
*Cyanide	.107	.044
*Lead	.154	.073
Nickel	.705	.466
*Silver	.151	.062
Zinc	.536	.224

BAT
Precious Metals Forming
Stationary Casting Contact Cooling Water

There shall be no discharge of process wastewater
pollutants.

BAT
Precious Metals Forming
Semi-Continuous and Continuous Casting CCW

Pollutant or pollutant property	Maximum for any one day	Maximum for monthly average
mg/off-kg (lb/million off-lbs) of precious metals cast by the semi-continuous or continuous method		
*Cadmium	.350	.155
Chromium	.453	.186
*Copper	1.960	1.030
*Cyanide	.299	.124
*Lead	.433	.206
Nickel	1.980	1.310
*Silver	.423	.175
Zinc	1.510	.629

Table X-31 (Continued)

PRECIOUS METALS FORMING SUBCATEGORY
BAT EFFLUENT LIMITATIONS

BAT
Precious Metals Forming
Heat Treatment Contact Cooling Water

Pollutant or pollutant property	Maximum for any one day	Maximum for monthly average
mg/off-kg (lb/million off-lbs) of extruded precious metals heat treated		
*Cadmium	.142	.063
Chromium	.184	.075
*Copper	.793	.417
*Cyanide	.121	.050
*Lead	.175	.083
Nickel	.801	.530
*Silver	.171	.071
Zinc	.609	.255

BAT
Precious Metals Forming
Surface Treatment Spent Baths

Pollutant or pollutant property	Maximum for any one day	Maximum for monthly average
mg/off-kg (lb/million off-lbs) of precious metals surface treated		
*Cadmium	.033	.015
Chromium	.042	.017
*Copper	.183	.096
*Cyanide	.028	.012
*Lead	.041	.019
Nickel	.185	.123
*Silver	.040	.016
Zinc	.141	.059

Table X-31 (Continued)

PRECIOUS METALS FORMING SUBCATEGORY
BAT EFFLUENT LIMITATIONS

BAT
Precious Metals Forming
Surface Treatment Rinse

Pollutant or pollutant property	Maximum for any one day	Maximum for monthly average
mg/off-kg (lb/million off-lbs) of precious metals surface treated		
*Cadmium	.210	.092
Chromium	.271	.111
*Copper	1.170	.616
*Cyanide	.179	.074
*Lead	.259	.123
Nickel	1.180	.783
*Silver	.253	.105
Zinc	.900	.376

BAT
Precious Metals Forming
Alkaline Cleaning Spent Baths

Pollutant or pollutant property	Maximum for any one day	Maximum for monthly average
mg/off-kg (lb/million off-lbs) of precious metals alkaline cleaned		
*Cadmium	.020	.009
Chromium	.026	.011
*Copper	.114	.060
*Cyanide	.017	.007
*Lead	.025	.012
Nickel	.115	.076
*Silver	.025	.010
Zinc	.088	.037

Table X-31 (Continued)

PRECIOUS METALS FORMING SUBCATEGORY
BAT EFFLUENT LIMITATIONS

BAT
Precious Metals Forming
Alkaline Cleaning Rinse

Pollutant or pollutant property	Maximum for any one day	Maximum for monthly average
mg/off-kg (lb/million off-lbs) of precious metals alkaline cleaned		
*Cadmium	.381	.168
Chromium	.493	.202
*Copper	2.130	1.120
*Cyanide	.325	.135
*Lead	.471	.224
Nickel	2.150	1.420
*Silver	.459	.191
Zinc	1.640	.683

BAT
Precious Metals Forming
Alkaline Cleaning Prebonding Wastewater

Pollutant or pollutant property	Maximum for any one day	Maximum for monthly average
mg/off-kg (lb/million off-lbs) of precious metals and base metal cleaned prior to bonding		
*Cadmium	.395	.174
Chromium	.511	.209
*Copper	2.210	1.160
*Cyanide	.337	.139
*Lead	.487	.232
Nickel	2.230	1.480
*Silver	.476	.197
Zinc	1.700	.708

Table X-31 (Continued)

PRECIOUS METALS FORMING SUBCATEGORY
BAT EFFLUENT LIMITATIONS

BAT
Precious Metals Forming
Tumbling or Burnishing Wastewater

Pollutant or pollutant property	Maximum for any one day	Maximum for monthly average
mg/off-kg (lb/million off-lbs) of precious metals tumbled or burnished		
*Cadmium	.412	.182
Chromium	.533	.218
*Copper	2.300	1.210
*Cyanide	.351	.145
*Lead	.508	.242
Nickel	2.330	1.540
*Silver	.496	.206
Zinc	1.770	.738

BAT
Precious Metals Forming
Sawing or Grinding Spent Neat Oils

There shall be no discharge of process wastewater
pollutants.

BAT
Precious Metals Forming
Sawing or Grinding Spent Emulsions

Pollutant or pollutant property	Maximum for any one day	Maximum for monthly average
mg/off-kg (lb/million off-lbs) of precious metals sawed or ground with emulsions		
*Cadmium	.032	.014
Chromium	.041	.017
*Copper	.178	.093
*Cyanide	.027	.011
*Lead	.039	.019
Nickel	.180	.119
*Silver	.038	.016
Zinc	.137	.057

Table X-31 (Continued)

PRECIOUS METALS FORMING SUBCATEGORY
 BAT EFFLUENT LIMITATIONS

BAT
 Precious Metals Forming
 Pressure Bonding Contact Cooling Water

Pollutant or pollutant property	Maximum for any one day	Maximum for monthly average
mg/off-kg (lb/million off-lbs) of precious metals and base metal pressure bonded		
*Cadmium	.028	.013
Chromium	.037	.015
*Copper	.159	.084
*Cyanide	.024	.010
*Lead	.035	.017
Nickel	.161	.106
*Silver	.034	.014
Zinc	.122	.051

BAT
 Precious Metals Forming
 Degreasing Spent Solvents

There shall be no discharge of process wastewater
 pollutants.

BAT
 Precious Metals Forming
 Wet Air Pollution Control Blowdown

There shall be no discharge of process wastewater
 pollutants.

Table X-32
 BAT REGULATORY FLOWS FOR THE
 PRODUCTION OPERATIONS - REFRACTORY METALS FORMING SUBCATEGORY

Operation	Waste Stream	Normalized BAT Discharge		Production Normalizing Parameter
		l/kgg	gal/ton	
Rolling	Spent neat oils and graphite-based lubricants	0	0	
	Spent emulsions	429	103	Mass of refractory metals rolled with emulsions
Drawing	Spent lubricants	0	0	
Extrusion	Spent lubricants	0	0	
	Press hydraulic fluid leakage	1,190	285	Mass of refractory metals extruded
Forging	Spent lubricants	0	0	
	Contact cooling water	32.3	7.75	Mass of forged refractory metals cooled with water
Metal Powder Production	Wastewater	281	67.3	Mass of refractory metals powder produced using water
	Floor wash water	0	0	
Metal Powder Pressing	Spent lubricants	0	0	
Surface Treatment	Spent baths	389	93.3	Mass of refractory metals surface treated
	Rinsewater	12,100	2,910	Mass of refractory metals surface treated
Alkaline Cleaning	Spent baths	334	80.2	Mass of refractory metals alkaline cleaned
	Rinsewater	8,160	1,960	Mass of refractory metals alkaline cleaned
Molten Salt	Rinsewater	633	152	Mass of refractory metals treated with molten salt
Tumbling or Burnishing	Wastewater	1,250	300	Mass of refractory metals tumbled or burnished with water-based media

Table X-32 (Continued)

BAT REGULATORY FLOWS FOR THE
PRODUCTION OPERATIONS - REFRACTORY METALS FORMING SUBCATEGORY

Operation	Waste Stream	Normalized BAT Discharge		Production Normalizing Parameter
		l/kgg	gal/ton	
Sawing or Grinding	Spent neat oils	0	0	
	Spent emulsions	297	71.1	Mass of refractory metals sawed or ground with emulsions
	Contact cooling water	2,430	582	Mass of refractory metals sawed or ground with contact cooling water
	Rinsewater	13.5	3.25	Mass of refractory metals sawed or ground and subsequently rinsed
Dye Penetrant Testing	Wastewater	77.6	18.6	Mass of refractory metals tested with dye penetrant methods
Equipment Cleaning	Wastewater	136	32.6	Mass of refractory metals formed on equipment requiring cleaning with water
Miscellaneous Wastewater Sources	Various	345	83.0	Mass of refractory metals formed
Degreasing	Spent solvents	0	0	
Wet Air Pollution Control	Blowdown	787	189	Mass of refractory metals sawed, ground, surface coated or surface treated

Table X-33

REFRACTORY METALS FORMING SUBCATEGORY
BAT EFFLUENT LIMITATIONS

BAT

Refractory Metals Forming
Rolling Spent Neat Oils and Graphite-Based Lubricants

There shall be no discharge of process wastewater pollutants.

BAT

Refractory Metals Forming
Rolling Spent Emulsions

Pollutant or pollutant property	Maximum for any one day	Maximum for monthly average
mg/off-kg (lb/million off-lbs) of refractory metals rolled with emulsions		
Chromium	.159	.064
*Copper	.549	.262
Lead	.120	.056
*Nickel	.236	.159
Silver	.125	.052
Zinc	.438	.180
Columbium	.052	---
*Fluoride	25.500	11.300
*Molybdenum	2.160	.957
Tantalum	.193	---
Vanadium	.043	---
Tungsten	1.490	.665

BAT

Refractory Metals Forming
Drawing Spent Lubricants

There shall be no discharge of process wastewater pollutants.

BAT

Refractory Metals Forming
Extrusion Spent Lubricants

There shall be no discharge of process wastewater pollutants.

Table X-33 (Continued)

REFRACTORY METALS FORMING SUBCATEGORY
BAT EFFLUENT LIMITATIONS

BAT
Refractory Metals Forming
Extrusion Press Hydraulic Fluid Leakage

Pollutant or pollutant property	Maximum for any one day	Maximum for monthly average
mg/off-kg (lb/million off-lbs) of refractory metals extruded		
Chromium	.441	.179
*Copper	1.530	.726
Lead	.333	.155
*Nickel	.655	.441
Silver	.345	.143
Zinc	1.220	.500
Columbium	.143	---
*Fluoride	70.800	31.400
*Molybdenum	5.990	2.660
Tantalum	.536	---
Vanadium	.119	---
Tungsten	4.140	1.850

BAT
Refractory Metals Forming
Forging Spent Lubricants

There shall be no discharge of process wastewater
pollutants.

Table X-33 (Continued)

REFRACTORY METALS FORMING SUBCATEGORY
BAT EFFLUENT LIMITATIONS

BAT
Refractory Metals Forming
Forging Contact Cooling Water

Pollutant or pollutant property	Maximum for any one day	Maximum for monthly average
mg/off-kg (lb/million off-lbs) of forged refractory metals cooled with water		
Chromium	.012	.005
*Copper	.041	.020
Lead	.009	.004
*Nickel	.018	.012
Silver	.009	.004
Zinc	.033	.014
Columbium	.004	---
*Fluoride	1.920	.853
*Molybdenum	.163	.072
Tantalum	.015	---
Vanadium	.003	---
Tungsten	.113	.050

BAT
Refractory Metals Forming
Metal Powder Production Wastewater

Pollutant or pollutant property	Maximum for any one day	Maximum for monthly average
mg/off-kg (lb/million off-lbs) of refractory metals powder produced		
Chromium	.104	.042
*Copper	.360	.172
Lead	.079	.037
*Nickel	.155	.104
Silver	.082	.034
Zinc	.287	.118
Columbium	.034	---
*Fluoride	16.700	7.420
*Molybdenum	1.420	.627
Tantalum	.127	---
Vanadium	.028	---
Tungsten	.978	.436

Table X-33 (Continued)

REFRACTORY METALS FORMING SUBCATEGORY
BAT EFFLUENT LIMITATIONS

BAT
Refractory Metals Forming
Metal Powder Production Floor Wash Water

There shall be no discharge of process wastewater pollutants.

BAT
Refractory Metals Forming
Metal Powder Pressing Spent Lubricants

There shall be no discharge of process wastewater pollutants.

BAT
Refractory Metals Forming
Surface Treatment Spent Baths

Pollutant or pollutant property	Maximum for any one day	Maximum for monthly average
mg/off-kg (lb/million off-lbs) of refractory metals surface treated		
Chromium	.144	.058
*Copper	.498	.237
Lead	.109	.051
*Nickel	.214	.144
Silver	.113	.047
Zinc	.397	.164
Columbium	.047	---
*Fluoride	23.200	10.300
*Molybdenum	1.960	.868
Tantalum	.175	---
Vanadium	.039	---
Tungsten	1.360	.603

Table X-33 (Continued)

REFRACTORY METALS FORMING SUBCATEGORY
BAT EFFLUENT LIMITATIONSBAT
Refractory Metals Forming
Surface Treatment Rinse

Pollutant or pollutant property	Maximum for any one day	Maximum for monthly average
mg/off-kg (lb/million off-lbs) of refractory metals surface treated		
Chromium	4.480	1.820
*Copper	15.500	7.380
Lead	3.390	1.580
*Nickel	6.660	4.480
Silver	3.510	1.450
Zinc	12.400	5.080
Columbium	1.450	---
*Fluoride	720.000	320.000
*Molybdenum	60.900	27.000
Tantalum	5.450	---
Vanadium	1.210	---
Tungsten	42.100	18.800

BAT
Refractory Metals Forming
Alkaline Cleaning Spent Baths

Pollutant or pollutant property	Maximum for any one day	Maximum for monthly average
mg/off-kg (lb/million off-lbs) of refractory metals alkaline cleaned		
Chromium	.124	.050
*Copper	.428	.204
Lead	.094	.043
*Nickel	.184	.124
Silver	.097	.040
Zinc	.341	.140
Columbium	.040	---
*Fluoride	19.900	8.820
*Molybdenum	1.680	.745
Tantalum	.151	---
Vanadium	.033	---
Tungsten	1.160	.518

Table X-33 (Continued)

REFRACTORY METALS FORMING SUBCATEGORY
BAT EFFLUENT LIMITATIONSBAT
Refractory Metals Forming
Alkaline Cleaning Rinse

Pollutant or pollutant property	Maximum for any one day	Maximum for monthly average
mg/off-kg (lb/million off-lbs) of refractory metals alkaline cleaned		
Chromium	3.020	1.230
*Copper	10.500	4.980
Lead	2.290	1.060
*Nickel	4.490	3.020
Silver	2.370	.979
Zinc	8.330	3.430
Columbium	.979	---
*Fluoride	486.000	216.000
*Molybdenum	41.100	18.200
Tantalum	3.670	---
Vanadium	.816	---
Tungsten	28.400	12.700

BAT
Refractory Metals Forming
Molten Salt Rinse

Pollutant or pollutant property	Maximum for any one day	Maximum for monthly average
mg/off-kg (lb/million off-lbs) of refractory metals treated with molten salt		
Chromium	.234	.095
*Copper	.810	.386
Lead	.177	.082
*Nickel	.348	.234
Silver	.184	.076
Zinc	.646	.266
Columbium	.076	---
*Fluoride	37.700	16.700
*Molybdenum	3.190	1.410
Tantalum	.285	---
Vanadium	.063	---
Tungsten	2.200	.981

Table X-33 (Continued)

REFRACTORY METALS FORMING SUBCATEGORY
BAT EFFLUENT LIMITATIONS

BAT
Refractory Metals Forming
Tumbling or Burnishing Wastewater

Pollutant or pollutant property	Maximum for any one day	Maximum for monthly average
mg/off-kg (lb/million off-lbs) of refractory metals tumbled or burnished		
Chromium	.463	.188
*Copper	1.600	.763
Lead	.350	.163
*Nickel	.688	.463
Silver	.363	.150
Zinc	1.280	.525
Columbium	.150	---
*Fluoride	74.400	33.000
*Molybdenum	6.290	2.790
Tantalum	.563	---
Vanadium	.125	---
Tungsten	4.350	1.940

BAT
Refractory Metals Forming
Sawing or Grinding Spent Neat Oils

There shall be no discharge of process wastewater
pollutants.

Table X-33 (Continued)

REFRACTORY METALS FORMING SUBCATEGORY
BAT EFFLUENT LIMITATIONS

BAT
Refractory Metals Forming
Sawing or Grinding Spent Emulsions

Pollutant or pollutant property	Maximum for any one day	Maximum for monthly average
mg/off-kg (lb/million off-lbs) of refractory metals sawed or ground with emulsions		
Chromium	.110	.045
*Copper	.380	.181
Lead	.083	.039
*Nickel	.164	.110
Silver	.086	.036
Zinc	.303	.125
Columbium	.036	---
*Fluoride	17.700	7.840
*Molybdenum	1.500	.663
Tantalum	.134	---
Vanadium	.030	---
Tungsten	1.040	.461

BAT
Refractory Metals Forming
Sawing or Grinding Contact Cooling Water

Pollutant or pollutant property	Maximum for any one day	Maximum for monthly average
mg/off-kg (lb/million off-lbs) of refractory metals sawed or ground with contact cooling water		
Chromium	.899	.365
*Copper	3.110	1.480
Lead	.681	.316
*Nickel	1.340	.899
Silver	.705	.292
Zinc	2.480	1.020
Columbium	.292	---
*Fluoride	145.000	64.200
*Molybdenum	12.200	5.420
Tantalum	1.100	---
Vanadium	.243	---
Tungsten	8.460	3.770

Table X-33 (Continued)

REFRACTORY METALS FORMING SUBCATEGORY
BAT EFFLUENT LIMITATIONS

BAT

Refractory Metals Forming
Sawing or Grinding Rinse

Pollutant or pollutant property	Maximum for any one day	Maximum for monthly average
mg/off-kg (lb/million off-lbs) of sawed or ground refractory metals rinsed		
Chromium	.005	.002
*Copper	.017	.008
Lead	.004	.002
*Nickel	.007	.005
Silver	.004	.002
Zinc	.014	.006
Columbium	.002	---
*Fluoride	.803	.357
*Molybdenum	.068	.030
Tantalum	.006	---
Vanadium	.001	---
Tungsten	.047	.021

BAT

Refractory Metals Forming
Dye Penetrant Testing Wastewater

Pollutant or pollutant property	Maximum for any one day	Maximum for monthly average
mg/off-kg (lb/million off-lbs) of refractory metals tested with dye penetrant methods		
Chromium	.029	.012
*Copper	.099	.047
Lead	.022	.010
*Nickel	.043	.029
Silver	.023	.009
Zinc	.079	.033
Columbium	.009	---
*Fluoride	4.620	2.050
*Molybdenum	.391	.173
Tantalum	.035	---
Vanadium	.008	---
Tungsten	.270	.120

Table X-33 (Continued)

REFRACTORY METALS FORMING SUBCATEGORY
BAT EFFLUENT LIMITATIONS

BAT
Refractory Metals Forming
Equipment Cleaning Wastewater

Pollutant or pollutant property	Maximum for any one day	Maximum for monthly average
mg/off-kg (lb/million off-lbs) of refractory metals formed		
Chromium	.050	.020
*Copper	.174	.083
Lead	.038	.018
*Nickel	.075	.050
Silver	.040	.016
Zinc	.139	.057
Columbium	.016	---
*Fluoride	8.090	3.590
*Molybdenum	.684	.303
Tantalum	.061	---
Vanadium	.014	---
Tungsten	.473	.211

BAT
Refractory Metals Forming
Miscellaneous Wastewater Sources

Pollutant or pollutant property	Maximum for any one day	Maximum for monthly average
mg/off-kg (lb/million off-lbs) of refractory metals formed		
Chromium	.128	.052
*Copper	.442	.211
Lead	.097	.045
*Nickel	.190	.128
Silver	.100	.041
Zinc	.352	.145
Columbium	.041	---
*Fluoride	20.500	9.110
*Molybdenum	1.740	.770
Tantalum	.155	---
Vanadium	.035	---
Tungsten	1.200	.535

Table X-33 (Continued)

REFRACTORY METALS FORMING SUBCATEGORY
BAT EFFLUENT LIMITATIONS

BAT
Refractory Metals Forming
Degreasing Spent Solvents

There shall be no discharge of process wastewater pollutants.

BAT
Refractory Metals Forming
Wet Air Pollution Control Blowdown

Pollutant or pollutant property	Maximum for any one day	Maximum for monthly average
mg/off-kg (lb/million off-lbs) of refractory metals formed		
Chromium	.291	.118
*Copper	1.010	.480
Lead	.221	.103
*Nickel	.433	.291
Silver	.228	.095
Zinc	.803	.331
Columbium	.095	---
*Fluoride	46.800	20.800
*Molybdenum	3.960	1.760
Tantalum	.354	---
Vanadium	.079	---
Tungsten	2.740	1.220

Table X-34

BAT REGULATORY FLOWS FOR THE
PRODUCTION OPERATIONS - TITANIUM FORMING SUBCATEGORY

Operation	Waste Stream	Normalized BAT Discharge		Production Normalizing Parameter
		l/kg	gal/ton	
Rolling	Spent neat oils	0	0	
	Contact cooling water	488	117	Mass of titanium rolled with contact cooling water
Drawing	Spent neat oils	0	0	
Extrusion	Spent neat oils	0	0	
	Spent emulsions	71.9	17.2	Mass of titanium extruded with emulsions
	Press hydraulic fluid leakage	178	42.8	Mass of titanium extruded
Forging	Spent lubricants	0	0	
	Contact cooling water	99.9	24.0	Mass of forged titanium cooled with water
	Equipment cleaning wastewater	40.0	9.60	Mass of titanium forged on equipment requiring cleaning with water
	Press hydraulic fluid leakage	1,010	242	Mass of titanium forged
Tube Reducing	Spent lubricants	0	0	
Heat Treatment	Contact cooling water	0	0	
Surface Treatment	Spent baths	208	49.9	Mass of titanium surface treated
	Rinsewater	2,920	700	Mass of titanium surface treated
Alkaline Cleaning	Spent baths	240	57.5	Mass of titanium alkaline cleaned
	Rinsewater	276	66.3	Mass of titanium alkaline cleaned
Molten Salt	Rinsewater	955	229	Mass of titanium treated with molten salt
Tumbling	Wastewater	79.0	18.9	Mass of titanium tumbled with

698T

water-based media

Table X-34 (Continued)
 BAT REGULATORY FLOWS FOR THE
 PRODUCTION OPERATIONS - TITANIUM FORMING SUBCATEGORY

Operation	Waste Stream	Normalized BAT Discharge		Production Normalizing Parameter
		l/kg	gal/ton	
Sawing or Grinding	Spent neat oils	0	0	
	Spent emulsions	183	43.8	Mass of titanium sawed or ground with an emulsion
	Contact cooling water	476	114	Mass of titanium sawed or ground with contact cooling water
Dye Penetrant Testing	Wastewater	1,120	268	Mass of titanium tested with dye penetrant methods
Hydrotesting	Wastewater	0	0	
Miscellaneous Wastewater Sources	Various	32.4	7.77	Mass of titanium formed
Degreasing	Spent solvents	0	0	
Wet Air Pollution Control	Blowdown	214	51.4	Mass of titanium surface treated or forged

1870

Table X-35

TITANIUM FORMING SUBCATEGORY
BAT EFFLUENT LIMITATIONS

BAT
Titanium Forming
Rolling Spent Neat Oils

There shall be no discharge of process wastewater pollutants.

BAT
Titanium Forming
Rolling Contact Cooling Water

Pollutant or pollutant property	Maximum for any one day	Maximum for monthly average
mg/off-kg (lb/million off-lbs) of titanium rolled with contact cooling water		
Chromium	.215	.088
Copper	.927	.488
*Cyanide	.142	.059
*Lead	.205	.098
Nickel	.937	.620
*Zinc	.713	.298
*Ammonia	65.100	28.600
*Fluoride	29.100	12.900
Titanium	.459	.200

BAT
Titanium Forming
Drawing Spent Neat Oils

There shall be no discharge of process wastewater pollutants.

BAT
Titanium Forming
Extrusion Spent Neat Oils

There shall be no discharge of process wastewater pollutants.

Table X-35 (Continued)

TITANIUM FORMING SUBCATEGORY
BAT EFFLUENT LIMITATIONS

BAT
Titanium Forming
Extrusion Spent Emulsions

Pollutant or pollutant property	Maximum for any one day	Maximum for monthly average
mg/off-kg (lb/million off-lbs) of titanium extruded with emulsions		
Chromium	.032	.013
Copper	.137	.072
*Cyanide	.021	.009
*Lead	.030	.014
Nickel	.138	.091
*Zinc	.105	.044
*Ammonia	9.590	4.220
*Fluoride	4.280	1.900
Titanium	.068	.030

BAT
Titanium Forming
Extrusion Press Hydraulic Fluid Leakage

Pollutant or pollutant property	Maximum for any one day	Maximum for monthly average
mg/off-kg (lb/million off-lbs) of titanium extruded		
Chromium	.078	.032
Copper	.338	.178
*Cyanide	.052	.021
*Lead	.075	.036
Nickel	.342	.226
*Zinc	.260	.109
*Ammonia	23.700	10.500
*Fluoride	10.600	4.700
Titanium	.168	.073

Table X-35 (Continued)

TITANIUM FORMING SUBCATEGORY
BAT EFFLUENT LIMITATIONS

BAT
Titanium Forming
Forging Spent Lubricants

There shall be no discharge of process wastewater pollutants.

BAT
Titanium Forming
Forging Contact Cooling Water

Pollutant or pollutant property	Maximum for any one day	Maximum for monthly average
mg/off-kg (lb/million off-lbs) of forged titanium cooled with water		
Chromium	.044	.018
Copper	.190	.100
*Cyanide	.029	.012
*Lead	.042	.020
Nickel	.192	.127
*Zinc	.146	.061
*Ammonia	13.300	5.860
*Fluoride	5.950	2.640
Titanium	.094	.041

Table X-35 (Continued)

TITANIUM FORMING SUBCATEGORY
BAT EFFLUENT LIMITATIONS

BAT
Titanium Forming
Forging Equipment Cleaning Wastewater

Pollutant or pollutant property	Maximum for any one day	Maximum for monthly average
mg/off-kg (lb/million off-lbs) of titanium forged		
Chromium	.018	.007
Copper	.076	.040
*Cyanide	.012	.005
*Lead	.017	.008
Nickel	.077	.051
*Zinc	.058	.024
*Ammonia	5.330	2.350
*Fluoride	2.380	1.060
Titanium	.038	.016

BAT
Titanium Forming
Forging Press Hydraulic Fluid Leakage

Pollutant or pollutant property	Maximum for any one day	Maximum for monthly average
mg/off-kg (lb/million off-lbs) of titanium forged		
Chromium	.445	.182
Copper	1.920	1.010
*Cyanide	.293	.121
*Lead	.424	.202
Nickel	1.940	1.280
*Zinc	1.480	.616
*Ammonia	135.000	59.200
*Fluoride	60.100	26.700
Titanium	.950	.414

Table X-35 (Continued)

TITANIUM FORMING SUBCATEGORY
BAT EFFLUENT LIMITATIONS

BAT
Titanium Forming
Tube Reducing Spent Lubricants

There shall be no discharge of process wastewater pollutants.

BAT
Titanium Forming
Heat Treatment Contact Cooling Water

There shall be no allowance for the discharge of process wastewater pollutants.

BAT
Titanium Forming
Surface Treatment Spent Baths

Pollutant or pollutant property	Maximum for any one day	Maximum for monthly average
mg/off-kg (lb/million off-lbs) of titanium surface treated		
Chromium	.092	.038
Copper	.395	.208
*Cyanide	.060	.025
*Lead	.087	.042
Nickel	.400	.264
*Zinc	.304	.127
*Ammonia	27.700	12.200
*Fluoride	12.400	5.490
Titanium	.196	.085

Table X-35 (Continued)

TITANIUM FORMING SUBCATEGORY
BAT EFFLUENT LIMITATIONS

BAT
Titanium Forming
Surface Treatment Rinse

Pollutant or pollutant property	Maximum for any one day	Maximum for monthly average
mg/off-kg (lb/million off-lbs) of titanium surface treated		
Chromium	1.290	.526
Copper	5.550	2.920
*Cyanide	.847	.351
*Lead	1.230	.584
Nickel	5.610	3.710
*Zinc	4.270	1.780
*Ammonia	389.000	171.000
*Fluoride	174.000	77.100
Titanium	2.750	1.200

BAT
Titanium Forming
Alkaline Cleaning Spent Baths

Pollutant or pollutant property	Maximum for any one day	Maximum for monthly average
mg/off-kg (lb/million off-lbs) of titanium alkaline cleaned		
Chromium	.106	.043
Copper	.456	.240
*Cyanide	.070	.029
*Lead	.101	.048
Nickel	.461	.305
*Zinc	.351	.147
*Ammonia	32.000	14.100
*Fluoride	14.300	6.340
Titanium	.226	.098

Table X-35 (Continued)

TITANIUM FORMING SUBCATEGORY
BAT EFFLUENT LIMITATIONS

BAT
Titanium Forming
Alkaline Cleaning Rinse

Pollutant or pollutant property	Maximum for any one day	Maximum for monthly average
mg/off-kg (lb/million off-lbs) of titanium alkaline cleaned		
Chromium	.122	.050
Copper	.525	.276
*Cyanide	.080	.033
*Lead	.116	.055
Nickel	.530	.351
*Zinc	.403	.169
*Ammonia	36.800	16.200
*Fluoride	16.400	7.290
Titanium	.260	.113

BAT
Titanium Forming
Molten Salt Rinse

Pollutant or pollutant property	Maximum for any one day	Maximum for monthly average
mg/off-kg (lb/million off-lbs) of titanium treated with molten salt		
Chromium	.420	.172
Copper	1.820	.955
*Cyanide	.277	.115
*Lead	.401	.191
Nickel	1.840	1.210
*Zinc	1.400	.583
*Ammonia	128.000	56.000
*Fluoride	56.800	25.200
Titanium	.898	.392

Table X-35 (Continued)

TITANIUM FORMING SUBCATEGORY
BAT EFFLUENT LIMITATIONS

BAT
Titanium Forming
Tumbling Wastewater

Pollutant or pollutant property	Maximum for any one day	Maximum for monthly average
mg/off-kg (lb/million off-lbs) of titanium tumbled		
Chromium	.035	.014
Copper	.150	.079
*Cyanide	.023	.009
*Lead	.033	.016
Nickel	.152	.101
*Zinc	.116	.048
*Ammonia	10.600	4.630
*Fluoride	4.700	2.090
Titanium	.074	.032

BAT
Titanium Forming
Sawing or Grinding Spent Neat Oils

There shall be no discharge of process wastewater
pollutants.

Table X-35 (Continued)

TITANIUM FORMING SUBCATEGORY
BAT EFFLUENT LIMITATIONS

BAT
Titanium Forming
Sawing or Grinding Spent Emulsions

Pollutant or pollutant property	Maximum for any one day	Maximum for monthly average
mg/off-kg (lb/million off-lbs) of titanium sawed or ground with emulsions		
Chromium	.081	.033
Copper	.348	.183
*Cyanide	.053	.022
*Lead	.077	.037
Nickel	.352	.233
*Zinc	.267	.112
*Ammonia	24.400	10.700
*Fluoride	10.900	4.830
Titanium	.172	.075

BAT
Titanium Forming
Sawing or Grinding Contact Cooling Water

Pollutant or pollutant property	Maximum for any one day	Maximum for monthly average
mg/off-kg (lb/million off-lbs) of titanium sawed or ground with contact cooling water		
Chromium	.210	.086
Copper	.905	.476
*Cyanide	.138	.057
*Lead	.200	.095
Nickel	.914	.605
*Zinc	.695	.291
*Ammonia	63.500	27.900
*Fluoride	28.300	12.600
Titanium	.448	.195

Table X-35 (Continued)

TITANIUM FORMING SUBCATEGORY
BAT EFFLUENT LIMITATIONS

BAT

Titanium Forming

Dye Penetrant Testing Wastewater

Pollutant or pollutant property	Maximum for any one day	Maximum for monthly average
mg/off-kg (lb/million off-lbs) of titanium tested with dye penetrant methods		
Chromium	.493	.202
Copper	2.130	1.120
*Cyanide	.325	.135
*Lead	.471	.224
Nickel	2.150	1.420
*Zinc	1.640	.683
*Ammonia	149.000	65.700
*Fluoride	66.700	29.600
Titanium	1.050	.459

BAT

Titanium Forming

Miscellaneous Wastewater Sources

Pollutant or pollutant property	Maximum for any one day	Maximum for monthly average
mg/off-kg (lb/million off-lbs) of titanium formed		
Chromium	.014	.006
Copper	.062	.032
*Cyanide	.009	.004
*Lead	.014	.006
Nickel	.062	.041
*Zinc	.047	.020
*Ammonia	4.320	1.900
*Fluoride	1.930	.856
Titanium	.031	.013

Table X-35 (Continued)

TITANIUM FORMING SUBCATEGORY
BAT EFFLUENT LIMITATIONS

BAT
Titanium Forming
Degreasing Spent Solvents

There shall be no discharge of process wastewater pollutants.

BAT
Titanium Forming
Wet Air Pollution Control Blowdown

Pollutant or pollutant property	Maximum for any one day	Maximum for monthly average
mg/off-kg (lb/million off-lbs) of titanium formed		
Chromium	.094	.039
Copper	.407	.214
*Cyanide	.062	.026
*Lead	.090	.043
Nickel	.411	.272
*Zinc	.313	.131
*Ammonia	28.500	12.600
*Fluoride	12.800	5.650
Titanium	.201	.088

Table X-36

BAT REGULATORY FLOWS FOR THE
PRODUCTION OPERATIONS - URANIUM FORMING SUBCATEGORY

Operation	Waste Stream	Normalized BAT Discharge		Production Normalizing Parameter
		l/kgg	gal/ton	
Extrusion	Spent lubricants	0	0	
	Tool contact cooling water	34.4	8.25	Mass of uranium extruded with tools requiring contact cooling with water
Forging	Spent lubricants	0	0	
Heat Treatment	Contact cooling water	31.3	7.52	Mass of extruded or forged uranium heat treated and subsequently cooled with water
Surface Treatment	Spent baths	27.2	6.52	Mass of uranium surface treated
	Rinsewater	337	80.9	Mass of uranium surface treated
Sawing or Grinding	Spent emulsions	5.68	1.36	Mass of uranium sawed or ground with emulsions
	Contact cooling water	165	39.5	Mass of uranium sawed or ground with contact cooling water
	Rinsewater	4.65	1.12	Mass of uranium sawed or ground and subsequently rinsed
Area Cleaning	Washwater	42.9	10.3	Mass of uranium formed
Degreasing	Spent solvents	0	0	
Wet Air Pollution Control	Blowdown	3.49	0.836	Mass of uranium surface treated
Drum Washwater	Wastewater	44.3	10.6	Mass of uranium formed
Laundry Washwater	Wastewater	26.2*	6.30**	Employee-day

*Liters/employee-day.

**Gallons/employee-day.

Table X-37

URANIUM FORMING SUBCATEGORY
BAT EFFLUENT LIMITATIONS

BAT
Uranium Forming
Extrusion Spent Lubricants

There shall be no discharge of process wastewater pollutants.

BAT
Uranium Forming
Extrusion Tool Contact Cooling Water

Pollutant or pollutant property	Maximum for any one day	Maximum for monthly average
mg/off-kg (lb/million off-lbs) of uranium extruded		
*Cadmium	.007	.003
*Chromium	.013	.005
*Copper	.044	.021
*Lead	.010	.004
*Nickel	.019	.013
Zinc	.035	.015
*Fluoride	2.050	.908
*Molybdenum	.173	.077
Uranium	.148	.108

BAT
Uranium Forming
Forging Spent Lubricants

There shall be no discharge of process wastewater pollutants.

Table X-37 (Continued)

 URANIUM FORMING SUBCATEGORY
 BAT EFFLUENT LIMITATIONS

 BAT
 Uranium Forming
 Heat Treatment Contact Cooling Water

Pollutant or pollutant property	Maximum for any one day	Maximum for monthly average
mg/off-kg (lb/million off-lbs) of extruded or forged uranium heat treated		
*Cadmium	.006	.003
*Chromium	.012	.005
*Copper	.040	.019
*Lead	.009	.004
*Nickel	.017	.012
Zinc	.032	.013
*Fluoride	1.860	.827
*Molybdenum	.158	.070
Uranium	.134	.098

 BAT
 Uranium Forming
 Surface Treatment Spent Baths

Pollutant or pollutant property	Maximum for any one day	Maximum for monthly average
mg/off-kg (lb/million off-lbs) of uranium surface treated		
*Cadmium	.005	.002
*Chromium	.010	.004
*Copper	.035	.017
*Lead	.008	.004
*Nickel	.015	.010
Zinc	.028	.011
*Fluoride	1.620	.718
*Molybdenum	.137	.061
Uranium	.117	.085

Table X-37 (Continued)

URANIUM FORMING SUBCATEGORY
BAT EFFLUENT LIMITATIONS

BAT
Uranium Forming
Surface Treatment Rinse

Pollutant or pollutant property	Maximum for any one day	Maximum for monthly average
mg/off-kg (lb/million off-lbs) of uranium surface treated		
*Cadmium	.067	.027
*Chromium	.125	.051
*Copper	.432	.206
*Lead	.094	.044
*Nickel	.186	.125
Zinc	.344	.142
*Fluoride	20.100	8.900
*Molybdenum	1.700	.752
Uranium	1.450	1.050

BAT
Uranium Forming
Sawing or Grinding Spent Emulsions

Pollutant or pollutant property	Maximum for any one day	Maximum for monthly average
mg/off-kg (lb/million off-lbs) of uranium sawed or ground with emulsions		
*Cadmium	.0011	.0005
*Chromium	.0021	.0009
*Copper	.0073	.0035
*Lead	.0016	.0007
*Nickel	.0031	.0021
Zinc	.0058	.0024
*Fluoride	.3380	.1500
*Molybdenum	.0286	.0127
Uranium	.0244	.0178

Table X-37 (Continued)

URANIUM FORMING SUBCATEGORY
BAT EFFLUENT LIMITATIONS

BAT
Uranium Forming
Sawing or Grinding Contact Cooling Water

Pollutant or pollutant property	Maximum for any one day	Maximum for monthly average
mg/off-kg (lb/million off-lbs) of uranium sawed or ground with contact cooling water		
*Cadmium	.033	.013
*Chromium	.061	.025
*Copper	.211	.101
*Lead	.046	.022
*Nickel	.091	.061
Zinc	.169	.069
*Fluoride	9.820	4.360
*Molybdenum	.830	.368
Uranium	.708	.515

BAT
Uranium Forming
Sawing or Grinding Rinse

Pollutant or pollutant property	Maximum for any one day	Maximum for monthly average
mg/off-kg (lb/million off-lbs) of sawed or ground uranium rinsed		
*Cadmium	.0009	.0004
*Chromium	.0017	.0007
*Copper	.0060	.0028
*Lead	.0013	.0006
*Nickel	.0026	.0017
Zinc	.0048	.0020
*Fluoride	.2770	.1230
*Molybdenum	.0234	.0104
Uranium	.0200	.0145

Table X-37 (Continued)

URANIUM FORMING SUBCATEGORY
BAT EFFLUENT LIMITATIONS

BAT
Uranium Forming
Area Cleaning Washwater

Pollutant or pollutant property	Maximum for any one day	Maximum for monthly average
mg/off-kg (lb/million off-lbs) of uranium formed		
*Cadmium	.009	.003
*Chromium	.016	.006
*Copper	.055	.026
*Lead	.012	.006
*Nickel	.024	.016
Zinc	.044	.018
*Fluoride	2.550	1.130
*Molybdenum	.216	.096
Uranium	.184	.134

BAT
Uranium Forming
Degreasing Spent Solvents

There shall be no discharge of process wastewater
pollutants.

BAT
Uranium Forming
Wet Air Pollution Control Blowdown

Pollutant or pollutant property	Maximum for any one day	Maximum for monthly average
mg/off-kg (lb/million off-lbs) of uranium surface treated		
*Cadmium	.0007	.0003
*Chromium	.0013	.0005
*Copper	.0045	.0021
*Lead	.0010	.0005
*Nickel	.0019	.0013
Zinc	.0036	.0015
*Fluoride	.2080	.0922
*Molybdenum	.0176	.0078
Uranium	.0150	.0109

Table X-37 (Continued)

 URANIUM FORMING SUBCATEGORY
 BAT EFFLUENT LIMITATIONS

 BAT
 Uranium Forming
 Drum Washwater

Pollutant or pollutant property	Maximum for any one day	Maximum for monthly average
mg/off-kg (lb/million off-lbs) of uranium formed		
*Cadmium	.009	.004
*Chromium	.016	.007
*Copper	.057	.027
*Lead	.012	.006
*Nickel	.024	.016
Zinc	.045	.019
*Fluoride	2.640	1.170
*Molybdenum	.223	.099
Uranium	.190	.138

 BAT
 Uranium Forming
 Laundry Washwater

Pollutant or pollutant property	Maximum for any one day	Maximum for monthly average
mg/employee-day uranium formed		
Cadmium	5.240	2.100
Chromium	9.700	3.930
Copper	33.600	16.000
Lead	7.340	3.410
Nickel	14.400	9.700
Zinc	26.700	11.000
Fluoride	1,560.000	692.000
Molybdenum	132.000	58.400
Uranium	113.000	81.800

Table X-38

BAT REGULATORY FLOWS FOR THE
PRODUCTION OPERATIONS - ZINC FORMING SUBCATEGORY

Operation	Waste Stream	Normalized BAT Discharge		Production Normalizing Parameter
		l/kg	gal/ton	
Rolling	Spent neat oils	0	0	
	Spent emulsions	1.39	0.334	Mass of zinc rolled with emulsions
	Contact cooling water	53.6	12.9	Mass of zinc rolled with contact cooling water
Drawing	Spent emulsions	5.80	1.39	Mass of zinc drawn with emulsions
Casting				
Direct Chill Casting	Contact cooling water	50.5	12.1	Mass of zinc cast by the direct chill method
Stationary Casting	Contact cooling water	0	0	
Heat Treatment	Contact cooling water	76.3	18.3	Mass of zinc heat treated and subsequently cooled with water
Surface Treatment	Spent baths	88.7	21.3	Mass of zinc surface treated
	Rinsewater	358	85.9	Mass of zinc surface treated
Alkaline Cleaning	Spent baths	3.55	0.850	Mass of zinc alkaline cleaned
	Rinsewater	1,690	405	Mass of zinc alkaline cleaned
Sawing or Grinding	Spent emulsions	23.8	5.71	Mass of zinc sawed or ground with emulsions
Degreasing	Spent solvents	0	0	
Electrocoating	Rinsewater	229	55.0	Mass of zinc electrocoated

1889

Table X-39

ZINC FORMING SUBCATEGORY
BAT EFFLUENT LIMITATIONS

BAT
Zinc Forming
Rolling Spent Neat Oils

There shall be no discharge of process wastewater pollutants.

BAT
Zinc Forming
Rolling Spent Emulsions

Pollutant or pollutant property	Maximum for any one day	Maximum for monthly average
mg/off-kg (lb/million off-lbs) of zinc rolled with emulsions		
*Chromium	.0005	.0002
*Copper	.0018	.0009
*Cyanide	.0003	.0001
Nickel	.0008	.0005
*Zinc	.0014	.0006

BAT
Zinc Forming
Rolling Contact Cooling Water

Pollutant or pollutant property	Maximum for any one day	Maximum for monthly average
mg/off-kg (lb/million off-lbs) of zinc rolled with contact cooling water		
*Chromium	.020	.008
*Copper	.069	.033
*Cyanide	.011	.004
Nickel	.030	.020
*Zinc	.055	.023

Table X-39 (Continued)

ZINC FORMING SUBCATEGORY
BAT EFFLUENT LIMITATIONS

BAT
Zinc Forming
Drawing Spent Emulsions

Pollutant or pollutant property	Maximum for any one day	Maximum for monthly average
mg/off-kg (lb/million off-lbs) of zinc drawn with emulsions		
*Chromium	.0022	.0009
*Copper	.0074	.0035
*Cyanide	.0012	.0005
Nickel	.0032	.0022
*Zinc	.0059	.0024

BAT
Zinc Forming
Direct Chill Casting Contact Cooling Water

Pollutant or pollutant property	Maximum for any one day	Maximum for monthly average
mg/off-kg (lb/million off-lbs) of zinc cast by the direct chill method		
*Chromium	.019	.008
*Copper	.065	.031
*Cyanide	.010	.004
Nickel	.028	.019
*Zinc	.052	.021

BAT
Zinc Forming
Stationary Casting Contact Cooling Water

There shall be no discharge of process wastewater
pollutants.

Table X-39 (Continued)

ZINC FORMING SUBCATEGORY
BAT EFFLUENT LIMITATIONS

BAT
Zinc Forming
Heat Treatment Contact Cooling Water

Pollutant or pollutant property	Maximum for any one day	Maximum for monthly average
mg/off-kg (lb/million off-lbs) of zinc heat treated		
*Chromium	.028	.012
*Copper	.098	.047
*Cyanide	.015	.006
Nickel	.042	.028
*Zinc	.078	.032

BAT
Zinc Forming
Surface Treatment Spent Baths

Pollutant or pollutant property	Maximum for any one day	Maximum for monthly average
mg/off-kg (lb/million off-lbs) of zinc surface treated		
*Chromium	.033	.013
*Copper	.114	.054
*Cyanide	.018	.007
Nickel	.049	.033
*Zinc	.091	.037

Table X-39 (Continued)

ZINC FORMING SUBCATEGORY
BAT EFFLUENT LIMITATIONSBAT
Zinc Forming
Surface Treatment Rinse

Pollutant or pollutant property	Maximum for any one day	Maximum for monthly average
mg/off-kg (lb/million off-lbs) of zinc surface treated		
*Chromium	.133	.054
*Copper	.458	.219
*Cyanide	.072	.029
Nickel	.197	.133
*Zinc	.365	.151

BAT
Zinc Forming
Alkaline Cleaning Spent Baths

Pollutant or pollutant property	Maximum for any one day	Maximum for monthly average
mg/off-kg (lb/million off-lbs) of zinc alkaline cleaned		
*Chromium	.0013	.0005
*Copper	.0046	.0022
*Cyanide	.0007	.0003
Nickel	.0020	.0013
*Zinc	.0036	.0015

Table X-39 (Continued)

ZINC FORMING SUBCATEGORY
BAT EFFLUENT LIMITATIONS

BAT
Zinc Forming
Alkaline Cleaning Rinse

Pollutant or pollutant property	Maximum for any one day	Maximum for monthly average
mg/off-kg (lb/million off-lbs) of zinc alkaline cleaned		
*Chromium	.626	.254
*Copper	2.170	1.030
*Cyanide	.338	.135
Nickel	.930	.626
*Zinc	1.730	.710

BAT
Zinc Forming
Sawing or Grinding Spent Emulsions

Pollutant or pollutant property	Maximum for any one day	Maximum for monthly average
mg/off-kg (lb/million off-lbs) of zinc sawed or ground with emulsions		
*Chromium	.009	.004
*Copper	.031	.015
*Cyanide	.005	.002
Nickel	.013	.009
*Zinc	.024	.010

BAT
Zinc Forming
Degreasing Spent Solvents

There shall be no discharge of process wastewater
pollutants.

Table X-39 (Continued)

ZINC FORMING SUBCATEGORY
 BAT EFFLUENT LIMITATIONS

BAT
 Zinc Forming
 Electrocoating Rinse

Pollutant or pollutant property	Maximum for any one day	Maximum for monthly average
mg/off-kg (lb/million off-lbs) of zinc electrocoated		
*Chromium	.085	.034
*Copper	.293	.140
*Cyanide	.046	.018
Nickel	.126	.085
*Zinc	.234	.096

Table X-40

BAT REGULATORY FLOWS FOR THE
PRODUCTION OPERATIONS - ZIRCONIUM-HAFNIUM FORMING SUBCATEGORY

Operation	Waste Stream	Normalized BAT Discharge		Production Normalizing Parameter
		l/kgg	gal/ton	
Rolling	Spent neat oils	0	0	
Drawing	Spent lubricants	0	0	
Extrusion	Spent lubricants	0	0	
	Press hydraulic fluid leakage	237	56.9	Mass of zirconium-hafnium extruded
Swaging	Spent neat oils	0	0	
Tube Reducing	Spent lubricants	0	0	
Heat Treatment	Contact cooling water	34.3	8.23	Mass of zirconium-hafnium heat treated and subsequently cooled with water
Surface Treatment	Spent baths	340	81.5	Mass of zirconium-hafnium surface treated
	Rinsewater	888	213	Mass of zirconium-hafnium surface treated
Alkaline Cleaning	Spent baths	1,600	384	Mass of zirconium-hafnium alkaline cleaned
	Rinsewater	3,140	753	Mass of zirconium-hafnium alkaline cleaned
Molten Salt	Rinsewater	756	181	Mass of zirconium-hafnium treated with molten salt
Sawing or Grinding	Spent neat oils	0	0	
	Spent emulsions	281	67.4	Mass of zirconium-hafnium sawed or ground with emulsions
	Contact cooling water	321	77.0	Mass of zirconium-hafnium sawed or ground with contact cooling water
	Rinsewater	180	43.1	Mass of zirconium-hafnium sawed or ground and subsequently rinsed

968T

Table X-40 (Continued)
 BAT REGULATORY FLOWS FOR THE
 PRODUCTION OPERATIONS - ZIRCONIUM-HAFNIUM FORMING SUBCATEGORY

Operation	Waste Stream	Normalized BAT Discharge		Production Normalizing Parameter
		l/kg	gal/ton	
Inspection and Testing	Wastewater	15.4	3.70	Mass of zirconium-hafnium tested
Degreasing	Spent solvents	0	0	
Wet Air Pollution Control	Blowdown	0	0	
Degreasing	Rinsewater	0	0	

1897

Table X-41

ZIRCONIUM-HAFNIUM FORMING SUBCATEGORY
BAT EFFLUENT LIMITATIONS

BAT
Zirconium-Hafnium Forming
Rolling Spent Neat Oils

There shall be no discharge of process wastewater pollutants.

BAT
Zirconium-Hafnium Forming
Drawing Spent Lubricants

There shall be no discharge of process wastewater pollutants.

BAT
Zirconium-Hafnium Forming
Extrusion Spent Lubricants

There shall be no discharge of process wastewater pollutants.

BAT
Zirconium-Hafnium Forming
Extrusion Press Hydraulic Fluid Leakage

Pollutant or pollutant property	Maximum for any one day	Maximum for monthly average
mg/off-kg (lb/million off-lbs) of zirconium-hafnium extruded		
*Chromium	.104	.043
Copper	.451	.237
*Cyanide	.069	.029
Lead	.100	.047
*Nickel	.455	.301
Zinc	.346	.145
*Ammonia	31.600	13.900
*Fluoride	14.100	6.260
Zirconium	6.830	3.300

Table X-41 (Continued)

ZIRCONIUM-HAFNIUM FORMING SUBCATEGORY
BAT EFFLUENT LIMITATIONS

BAT
Zirconium-Hafnium Forming
Swaging Spent Neat Oils

There shall be no discharge of process wastewater pollutants.

BAT
Zirconium-Hafnium Forming
Tube Reducing Spent Lubricants

There shall be no discharge of process wastewater pollutants.

BAT
Zirconium-Hafnium Forming
Heat Treatment Contact Cooling Water

Pollutant or pollutant property	Maximum for any one day	Maximum for monthly average
mg/off-kg (lb/million off-lbs) of zirconium-hafnium heat treated		
*Chromium	.015	.006
Copper	.065	.034
*Cyanide	.010	.004
Lead	.014	.007
*Nickel	.066	.044
Zinc	.050	.021
*Ammonia	4.570	2.010
*Fluoride	2.040	.906
Zirconium	.988	.477

Table X-41 (Continued)

ZIRCONIUM-HAFNIUM FORMING SUBCATEGORY
BAT EFFLUENT LIMITATIONS

BAT
Zirconium-Hafnium Forming
Surface Treatment Spent Baths

Pollutant or pollutant property	Maximum for any one day	Maximum for monthly average
mg/off-kg (lb/million off-lbs) of zirconium-hafnium surface treated		
*Chromium	.150	.061
Copper	.646	.340
*Cyanide	.099	.041
Lead	.143	.068
*Nickel	.653	.432
Zinc	.497	.208
*Ammonia	45.300	19.900
*Fluoride	20.300	8.980
Zirconium	9.790	4.730

BAT
Zirconium-Hafnium Forming
Surface Treatment Rinse

Pollutant or pollutant property	Maximum for any one day	Maximum for monthly average
mg/off-kg (lb/million off-lbs) of zirconium-hafnium surface treated		
*Chromium	.391	.160
Copper	1.690	.888
*Cyanide	.258	.107
Lead	.373	.178
*Nickel	1.710	1.130
Zinc	1.300	.542
*Ammonia	119.000	52.100
*Fluoride	52.900	23.500
Zirconium	25.600	12.400

Table X-41 (Continued)

ZIRCONIUM-HAFNIUM FORMING SUBCATEGORY
BAT EFFLUENT LIMITATIONS

BAT
Zirconium-Hafnium Forming
Alkaline Cleaning Spent Baths

Pollutant or pollutant property	Maximum for any one day	Maximum for monthly average
mg/off-kg (lb/million off-lbs) of zirconium-hafnium alkaline cleaned		
*Chromium	.704	.288
Copper	3.040	1.600
*Cyanide	.464	.192
Lead	.672	.320
*Nickel	3.070	2.030
Zinc	2.340	.976
*Ammonia	213.000	93.800
*Fluoride	95.200	42.300
Zirconium	46.100	22.300

BAT
Zirconium-Hafnium Forming
Alkaline Cleaning Rinse

Pollutant or pollutant property	Maximum for any one day	Maximum for monthly average
mg/off-kg (lb/million off-lbs) of zirconium-hafnium alkaline cleaned		
*Chromium	1.380	.565
Copper	5.970	3.140
*Cyanide	.911	.377
Lead	1.320	.628
*Nickel	6.030	3.990
Zinc	4.590	1.920
*Ammonia	419.000	184.000
*Fluoride	187.000	82.900
Zirconium	90.500	43.700

Table X-41 (Continued)

ZIRCONIUM-HAFNIUM FORMING SUBCATEGORY
 BAT EFFLUENT LIMITATIONS

BAT
 Zirconium-Hafnium Forming
 Molten Salt Rinse

Pollutant or pollutant property	Maximum for any one day	Maximum for monthly average
mg/off-kg (lb/million off-lbs) of zirconium-hafnium treated with molten salt		
*Chromium	.333	.136
Copper	1.440	.756
*Cyanide	.219	.091
Lead	.318	.151
*Nickel	1.450	.960
Zinc	1.110	.461
*Ammonia	101.000	44.300
*Fluoride	45.000	20.000
Zirconium	21.800	10.500

BAT
 Zirconium-Hafnium Forming
 Sawing or Grinding Spent Neat Oils

There shall be no discharge of process wastewater
 pollutants.

Table X-41 (Continued)

ZIRCONIUM-HAFNIUM FORMING SUBCATEGORY
 BAT EFFLUENT LIMITATIONS

BAT
 Zirconium-Hafnium Forming
 Sawing or Grinding Spent Emulsions

Pollutant or pollutant property	Maximum for any one day	Maximum for monthly average
mg/off-kg (lb/million off-lbs) of zirconium-hafnium sawed or ground with emulsions		
*Chromium	.124	.051
Copper	.534	.281
*Cyanide	.082	.034
Lead	.118	.056
*Nickel	.540	.357
Zinc	.410	.172
*Ammonia	37.500	16.500
*Fluoride	16.700	7.420
Zirconium	8.090	3.910

BAT
 Zirconium-Hafnium Forming
 Sawing or Grinding Contact Cooling Water

Pollutant or pollutant property	Maximum for any one day	Maximum for monthly average
mg/off-kg (lb/million off-lbs) of zirconium-hafnium sawed or ground with contact cooling water		
*Chromium	.141	.058
Copper	.610	.321
*Cyanide	.093	.039
Lead	.135	.064
*Nickel	.617	.408
Zinc	.469	.196
*Ammonia	42.800	18.800
*Fluoride	19.100	8.480
Zirconium	9.250	4.460

Table X-41 (Continued)

ZIRCONIUM-HAFNIUM FORMING SUBCATEGORY
BAT EFFLUENT LIMITATIONS

BAT
Zirconium-Hafnium Forming
Sawing or Grinding Rinse

Pollutant or pollutant property	Maximum for any one day	Maximum for monthly average
mg/off-kg (lb/million off-lbs) of sawed or ground zirconium-hafnium rinsed		
*Chromium	.079	.032
Copper	.342	.180
*Cyanide	.052	.022
Lead	.076	.036
*Nickel	.346	.229
Zinc	.263	.110
*Ammonia	24.000	10.600
*Fluoride	10.700	4.750
Zirconium	5.190	2.500

BAT
Zirconium-Hafnium Forming
Inspection and Testing Wastewater

Pollutant or pollutant property	Maximum for any one day	Maximum for monthly average
mg/off-kg (lb/million off-lbs) of zirconium-hafnium tested		
*Chromium	.007	.003
Copper	.029	.015
*Cyanide	.004	.002
Lead	.006	.003
*Nickel	.030	.020
Zinc	.023	.009
*Ammonia	2.050	.903
*Fluoride	.917	.407
Zirconium	.444	.214

Table X-41 (Continued)

ZIRCONIUM-HAFNIUM FORMING SUBCATEGORY
BAT EFFLUENT LIMITATIONS

BAT
Zirconium-Hafnium Forming
Degreasing Spent Solvents

There shall be no discharge of process wastewater pollutants.

BAT
Zirconium-Hafnium Forming
Wet Air Pollution Control Blowdown

There shall be no allowance for the discharge of process wastewater pollutants.

BAT
Zirconium-Hafnium Forming
Degreasing Rinse

There shall be no discharge of process wastewater pollutants.

Table X-42

PRODUCTION OPERATIONS - METAL POWDERS SUBCATEGORY

Operation	Waste Stream	Normalized BAT Discharge		Production Normalizing Parameter
		l/kg	gal/ton	
Metal Powder Production	Atomization wastewater	5,040	1,210	Mass of powder produced by wet atomization
Tumbling, Burnishing or Cleaning	Wastewater	4,400	1,050	Mass of powder metallurgy parts tumbled, burnished or cleaned with water-based media
Sawing or Grinding	Spent neat oils	0	0	Mass of powder metallurgy parts sawed or ground with emulsions
	Spent emulsions	18.1	4.33	
	Contact cooling water	1,620	389	
Sizing	Spent neat oils	0	0	Mass of powder sized using emulsions
	Spent emulsions	14.6	3.50	
Steam Treatment Wet Air Pollution Control	Blowdown	792	190	Mass of powder metallurgy parts steam treated
Oil-Resin Impregnation	Spent neat oils	0	0	
Degreasing	Spent solvents	0	0	
Hot Pressing	Contact cooling water	8,800	2,110	Mass of powder cooled with water after pressing
Mixing Wet Air Pollution Control	Blowdown	7,900	1,890	Mass of powder mixed

Table X-43

METAL POWDERS SUBCATEGORY
BAT EFFLUENT LIMITATIONS

BAT
Metal Powders
Metal Powder Production Atomization Wastewater

Pollutant or pollutant property	Maximum for any one day	Maximum for monthly average
mg/off-kg (lb/million off-lbs) of powder wet atomized		
Chromium	2.220	.907
*Copper	9.580	5.040
*Cyanide	1.460	.605
*Lead	2.120	1.010
Nickel	9.680	6.400
Zinc	7.360	3.080
Aluminum	32.400	16.100
Iron	6.050	3.080

BAT
Metal Powders
Tumbling, Burnishing, or Cleaning Wastewater

Pollutant or pollutant property	Maximum for any one day	Maximum for monthly average
mg/off-kg (lb/million off-lbs) of powder metallurgy parts tumbled, burnished, or cleaned		
Chromium	1.940	.792
*Copper	8.360	4.400
*Cyanide	1.280	.528
*Lead	1.850	.880
Nickel	8.450	5.590
Zinc	6.430	2.690
Aluminum	28.300	14.100
Iron	5.280	2.690

Table X-43 (Continued)

METAL POWDERS SUBCATEGORY
BAT EFFLUENT LIMITATIONS

BAT
Metal Powders
Sawing or Grinding Spent Neat Oils

There shall be no discharge of process wastewater pollutants.

BAT
Metal Powders
Sawing or Grinding Spent Emulsions

Pollutant or pollutant property	Maximum for any one day	Maximum for monthly average
mg/off-kg (lb/million off-lbs) of powder metallurgy parts sawed or ground with emulsions		
Chromium	.008	.003
*Copper	.034	.018
*Cyanide	.005	.002
*Lead	.008	.004
Nickel	.035	.023
Zinc	.026	.011
Aluminum	.117	.058
Iron	.022	.011

BAT
Metal Powders
Sawing or Grinding Contact Cooling Water

Pollutant or pollutant property	Maximum for any one day	Maximum for monthly average
mg/off-kg (lb/million off-lbs) of powder metallurgy parts sawed or ground with contact cooling water		
Chromium	.713	.292
*Copper	3.080	1.620
*Cyanide	.470	.195
*Lead	.681	.324
Nickel	3.110	2.060
Zinc	2.370	.988
Aluminum	10.400	5.190
Iron	1.950	.988

Table X-43 (Continued)

METAL POWDERS SUBCATEGORY
BAT EFFLUENT LIMITATIONS

BAT
Metal Powders
Sizing Spent Neat Oils

There shall be no discharge of process wastewater pollutants.

BAT
Metal Powders
Sizing Spent Emulsions

Pollutant or pollutant property	Maximum for any one day	Maximum for monthly average
mg/off-kg (lb/million off-lbs) of powder sized		
Chromium	.006	.003
*Copper	.028	.015
*Cyanide	.004	.002
*Lead	.006	.003
Nickel	.028	.019
Zinc	.021	.009
Aluminum	.094	.047
Iron	.018	.009

BAT
Metal Powders
Steam Treatment Wet Air Pollution Control Blowdown

Pollutant or pollutant property	Maximum for any one day	Maximum for monthly average
mg/off-kg (lb/million off-lbs) of powder metallurgy parts steam treated		
Chromium	.349	.143
*Copper	1.510	.792
*Cyanide	.230	.095
*Lead	.333	.159
Nickel	1.520	1.010
Zinc	1.160	.483
Aluminum	5.090	2.540
Iron	.951	.483

Table X-43 (Continued)

METAL POWDERS SUBCATEGORY
 BAT EFFLUENT LIMITATIONS

BAT
 Metal Powders
 Oil-Resin Impregnation Spent Neat Oils

There shall be no discharge of process wastewater pollutants.

BAT
 Metal Powders
 Degreasing Spent Solvents

There shall be no discharge of process wastewater pollutants.

BAT
 Metal Powders
 Hot Pressing Contact Cooling Water

Pollutant or pollutant property	Maximum for any one day	Maximum for monthly average
mg/off-kg (lb/million off-lbs) of powder cooled after pressing		
Chromium	3.870	1.590
*Copper	16.700	8.800
*Cyanide	2.550	1.060
*Lead	3.700	1.760
Nickel	16.900	11.200
Zinc	12.900	5.370
Aluminum	56.600	28.200
Iron	10.600	5.370

Table X-43 (Continued)

METAL POWDERS SUBCATEGORY
 BAT EFFLUENT LIMITATIONS

BAT
 Metal Powders
 Mixing Wet Air Pollution Control Blowdown

Pollutant or pollutant property	Maximum for any one day	Maximum for monthly average
mg/off-kg (lb/million off-lbs) of powder mixed		
Chromium	3.480	1.420
*Copper	15.000	7.900
*Cyanide	2.290	.948
*Lead	3.320	1.580
Nickel	15.200	10.100
Zinc	11.600	4.820
Aluminum	50.800	25.300
Iron	9.480	4.820

1912

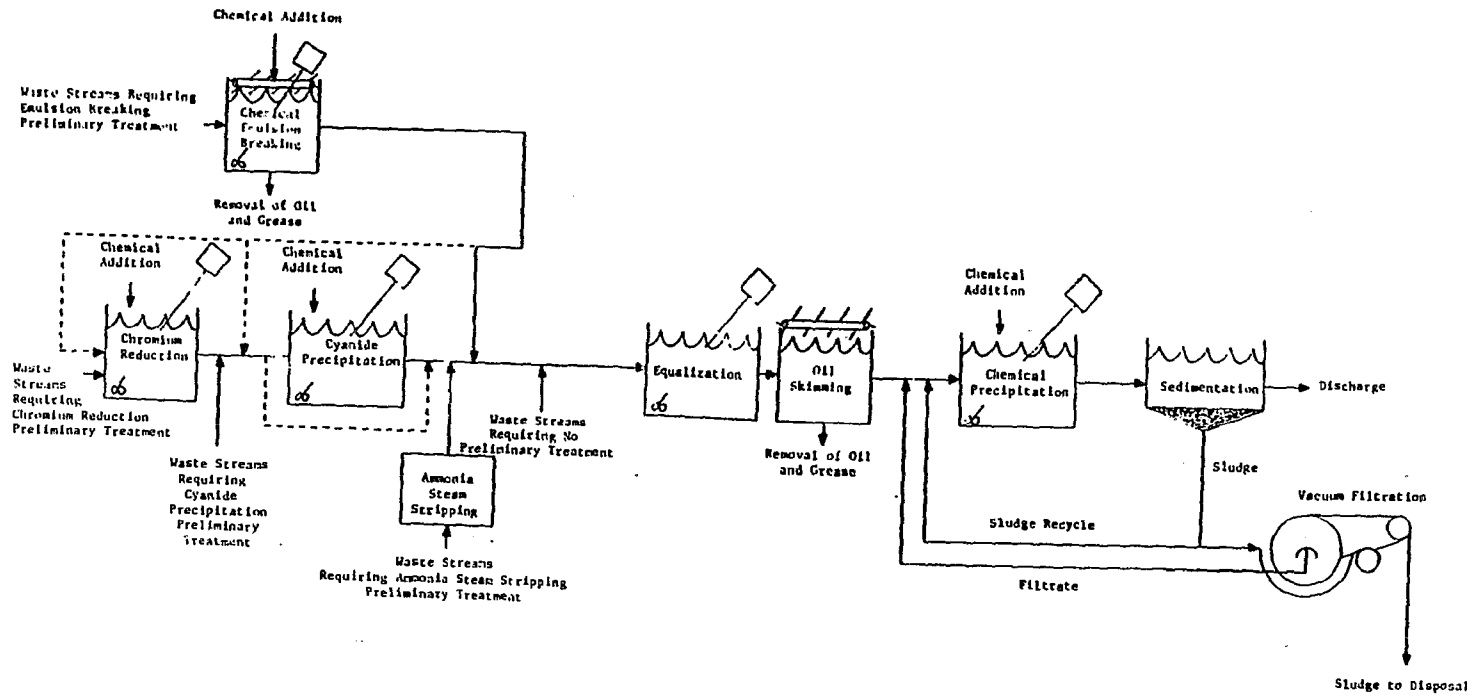

NOTE: 1) Waste streams which may require specific preliminary treatment are listed in Table IX-1.

2) Chemical precipitation includes iron coprecipitation when necessary to remove molybdenum.

Figure X-1

BAT OPTION 1 AND 2 TREATMENT TRAIN FOR THE NONFERROUS METALS FORMING CATEGORY

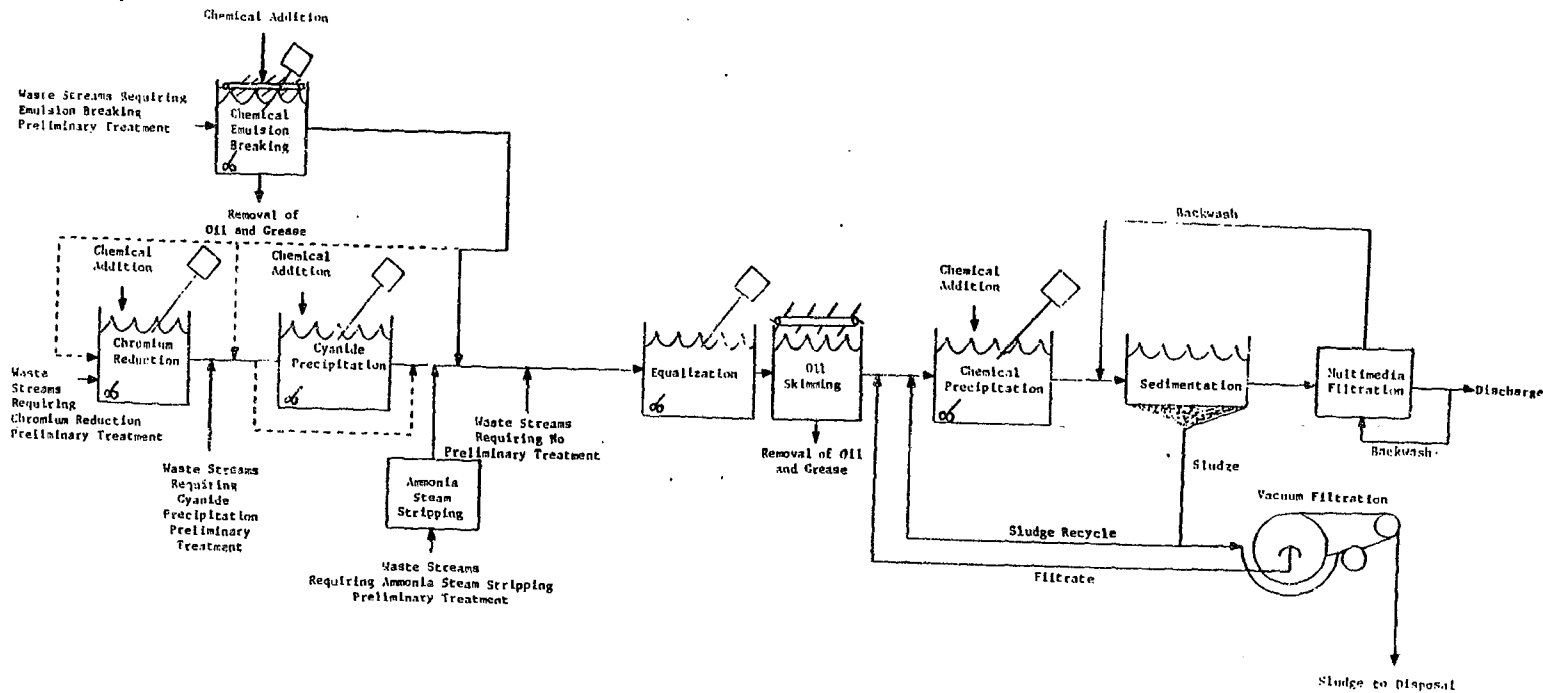

- NOTE: 1) Waste streams which may require specific preliminary treatment are listed in Table IX-1.
- 2) Chemical precipitation includes iron coprecipitation when necessary to remove molybdenum.

Figure X-2

BAT OPTION 3 TREATMENT TRAIN FOR THE NONFERROUS METALS FORMING CATEGORY

SECTION XI

NEW SOURCE PERFORMANCE STANDARDS

The basis for new source performance standards (NSPS) under Section 306 of the Clean Water Act is the best available demonstrated technology (BDT). New plants have the opportunity to design the best and most efficient production processes, and wastewater treatment technologies. Therefore, NSPS includes process changes, in-plant controls (including elimination of wastewater streams), operating procedure changes, and end-of-pipe treatment technologies to reduce pollution to the maximum extent possible. This section describes the control technology for treatment of wastewater from new sources and presents mass discharge limitations of regulated pollutants for NSPS, based on the described control technology.

TECHNICAL APPROACH TO NSPS

Most wastewater reduction and process changes applicable to a new source have been considered previously for the BAT options. For this reason, the three options considered as the basis for the BAT options in Section X were also considered for NSPS. The three options are summarized below and presented in greater detail in Section X.

In summary form, the treatment technologies considered for new nonferrous metals forming facilities are:

NSPS Option 1 is based on:

Oil skimming,
Lime and settle (chemical precipitation of metals followed by sedimentation),
pH adjustment; and, where required,
Iron co-precipitation,
Chemical emulsion breaking,
Ammonia steam stripping,
Cyanide removal, and
Hexavalent chromium reduction.

NSPS Option 2 is based on:

NSPS Option 1, plus process wastewater flow minimization by the following methods:

- Contact cooling water recycle through cooling towers or holding tanks.
- Air pollution control scrubber liquor recycle.
- Countercurrent cascade rinsing or other water efficient methods applied to surface treatment rinses and alkaline cleaning rinses.
- Use of periodic batch discharges or decreased flow rate for molten salt rinsewater.

- Recycle of equipment cleaning wastewater, tumbling, burnishing and cleaning wastewater, and other wastewater streams through holding tanks with suspended solids removal if necessary.

NSPS Option 3 is based on:

NSPS Option 2, plus multimedia filtration at the end of the NSPS Option 2 treatment train. Plus ion exchange for the precious metals subcategory.

A more detailed discussion of these options and their applicability with each of the 10 subcategories is presented in Section X.

NSPS OPTION SELECTION

EPA is issuing NSPS on the same technology basis as BAT for eight of the 10 subcategories in the nonferrous metals forming category. For the magnesium subcategory, EPA is issuing NSPS based on technology equivalent to BAT technology for that subcategory with the addition of filtration prior to discharge. For the metal powders subcategory, EPA is issuing NSPS based on technology equivalent to BAT technology for that subcategory with the additional process wastewater flow minimization. As discussed in Sections IX and X, these technologies are currently used at plants within this point source category.

EPA is issuing NSPS based on the application of lime, settle, and filter with in-process controls to reduce wastewater flows for the nickel-cobalt, refractory metals, uranium, and zinc forming subcategories. Filtration has been included in the NSPS model technology for subcategories because new plants have the opportunity to design the most efficient process water use and wastewater reduction techniques within their processes, thereby reducing the size of and cost of filtration equipment. Specifically, the design of new plants can be based on recycle of contact cooling water through cooling towers, recycle of air pollution control scrubber liquor or the use of dry air pollution control equipment, and use of countercurrent cascade rinsing. These reductions in water use in turn reduce the cost of wastewater treatment technologies, including filtration equipment. For the lead-tin-bismuth, precious metals, titanium, and zirconium-hafnium forming subcategories, the Agency is issuing NSPS on the basis of flow reduction, lime, and settle.

The NSPS regulatory flows are the same as the BAT regulatory flows discussed in Section X with the exception of three waste streams in the metal powders subcategory. These are tumbling, burnishing, and cleaning wastewater; steam treatment wet air pollution control blowdown; and hot pressing contact cooling water. The NSPS flows for these waste streams are based on recycle of process wastewater. Opportunities to achieve further flow reduction of process wastewater do currently exist for these process waste streams; however, they are not employed at existing direct discharge facilities. The Agency believes these processes

could be used at new sources. Further, a new plant has the opportunity to build into the plant when it is being constructed the necessary cooling towers, holding tanks or sedimentation equipment required to recycle these streams.

Table XI-1 presents a summary of the option selected as the basis for NSPS for each subcategory.

New sources regardless of whether they are plants with major modifications or greenfield sites, will have costs that are not greater than the costs that existing sources would incur in achieving equivalent pollutant discharge reduction. In fact, these costs may be less, since retrofitting is unnecessary. Based on this, the Agency believes that the selected NSPS is appropriate for both greenfield sites and existing sites undergoing major modifications (e.g., a primary zinc plant which installs a rolling operation).

Costs and Environmental Benefits of Treatment Options

Costs for an individual new source can be estimated using the methods described in Section VIII. The Agency has not estimated total costs or benefits for the category or subcategories since it is not known how many new nonferrous metals forming plants will be built.

REGULATED POLLUTANT PARAMETERS

The Agency has no reason to believe that the pollutants that will be found in significant quantities in processes within new sources will be any different than those found in existing sources. Consequently, pollutants selected for regulation, in accordance with the rationale of Section VI, are the same ones for each subcategory that were selected for BAT plus TSS, oil and grease, and pH. At NSPS, as at BAT, the other metal priority pollutants considered for regulation will be controlled by regulation of these selected pollutants.

NEW SOURCE PERFORMANCE STANDARDS

The regulatory production normalized flows for NSPS are the same as the production normalized flows for the selected BAT option with the exception of three streams in the metal powders subcategory. New plants can design and install recycle systems for these streams during original plant construction. As such, new plants would not incur the costs of retrofitting these recycle systems. The NSPS flow allowance for tumbling, burnishing and cleaning wastewater is 440 l/kg (105 gal/ton). The NSPS flow allowance for steam treatment wet air pollution control blowdown is 79.2 l/kg (19.0 gal/ton). The NSPS flow allowance for hot pressing contact cooling water is 880 l/kg (211 gal/ton). These flows are based on 90 percent flow reduction from BAT flows using process wastewater flow minimization techniques discussed in detail in Section X.

The treatment effectiveness for each subcategory is based on the values presented in Table VII-21 for lime and settle or lime, settle, and filter treatment. The mass of pollutant allowed to be discharged per mass of product is calculated by multiplying the appropriate treatment effectiveness value (one-day maximum and 10-day average values) (mg/l) by the production normalized flows (l/kg). When these calculations are performed, the mass-based NSPS can be derived for the selected option for each subcategory. These values are presented for each of the 10 subcategories in Tables XI-2 through XI-11.

Table XI-1

OPTIONS SELECTED AS THE TECHNOLOGY BASES FOR NSPS

Subcategory	NSPS
Lead-Tin-Bismuth Forming	Option 2
Magnesium Forming	Option 3
Nickel-Cobalt Forming	Option 3
Precious Metals Forming	Option 2
Refractory Metals Forming	Option 3
Titanium Forming	Option 2
Uranium Forming	Option 3
Zinc Forming	Option 3
Zirconium-Hafnium Forming	Option 2
Metal Powders	Option 2

Option 1 - Flow Normalization, Lime and Settle

Option 2 - Flow Reduction, Lime and Settle

Option 3 - Flow Reduction, Lime and Settle, Multimedia Filtration

Table XI-2

LEAD-TIN-BISMUTH FORMING SUBCATEGORY
NEW SOURCE PERFORMANCE STANDARDS

NSPS
Lead-Tin-Bismuth Forming
Rolling Spent Emulsions

Pollutant or pollutant property	Maximum for any one day	Maximum for monthly average
mg/off-kg (lb/million off-lbs) of lead-tin-bismuth rolled with emulsions		
*Antimony	.067	.030
*Lead	.010	.005
*Oil and Grease	.468	.281
*TSS	.960	.457
*pH	Within the range of 7.5 to 10.0 at all times	

NSPS
Lead-Tin-Bismuth Forming
Rolling Spent Soap Solutions

Pollutant or pollutant property	Maximum for any one day	Maximum for monthly average
mg/off-kg (lb/million off-lbs) of lead-tin-bismuth rolled with soap solutions		
*Antimony	.124	.055
*Lead	.018	.009
*Oil and Grease	.860	.516
*TSS	1.770	.839
*pH	Within the range of 7.5 to 10.0 at all times	

NSPS
Lead-Tin-Bismuth Forming
Drawing Spent Neat Oils

There shall be no discharge of process wastewater
pollutants.

Table XI-2 (Continued)

LEAD-TIN-BISMUTH FORMING SUBCATEGORY
NEW SOURCE PERFORMANCE STANDARDS

NSPS

Lead-Tin-Bismuth Forming
Drawing Spent Emulsions

Pollutant or pollutant property	Maximum for any one day	Maximum for monthly average
mg/off-kg (lb/million off-lbs) of lead-tin-bismuth drawn with emulsions		
*Antimony	.076	.034
*Lead	.011	.005
*Oil and Grease	.526	.316
*TSS	1.080	.513
*pH	Within the range of 7.5 to 10.0 at all times	

NSPS

Lead-Tin-Bismuth Forming
Drawing Spent Soap Solutions

Pollutant or pollutant property	Maximum for any one day	Maximum for monthly average
mg/off-kg (lb/million off-lbs) of lead-tin-bismuth drawn with soap solutions		
*Antimony	.021	.010
*Lead	.003	.001
*Oil and Grease	.149	.090
*TSS	.306	.146
*pH	Within the range of 7.5 to 10.0 at all times	

Table XI-2 (Continued)

LEAD-TIN-BISMUTH FORMING SUBCATEGORY
NEW SOURCE PERFORMANCE STANDARDS

NSPS

Lead-Tin-Bismuth Forming
Extrusion Press or Solution Heat Treatment Contact
Cooling Water

Pollutant or pollutant property	Maximum for any one day	Maximum for monthly average
mg/off-kg (lb/million off-lbs) of lead-tin-bismuth heat treated		
*Antimony	.413	.185
*Lead	.061	.029
*Oil and Grease	2.880	1.730
*TSS	5.910	2.810
* * Within the range of 7.5 to 10.0 at all times		

NSPS

Lead-Tin-Bismuth Forming
Extrusion Press Hydraulic Fluid Leakage

Pollutant or pollutant property	Maximum for any one day	Maximum for monthly average
mg/off-kg (lb/million off-lbs) of lead-tin-bismuth extruded		
*Antimony	.158	.070
*Lead	.023	.011
*Oil and Grease	1.100	.660
*TSS	2.260	1.070
*pH Within the range of 7.5 to 10.0 at all times		

Table XI-2 (Continued)

LEAD-TIN-BISMUTH FORMING SUBCATEGORY
NEW SOURCE PERFORMANCE STANDARDS

NSPS
Lead-Tin-Bismuth Forming
Swaging Spent Emulsions

Pollutant or pollutant property	Maximum for any one day	Maximum for monthly average
mg/off-kg (lb/million off-lbs) of lead-tin-bismuth swaged with emulsions		
*Antimony	.0051	.0023
*Lead	.0008	.0004
*Oil and Grease	.0354	.0213
*TSS	.0726	.0345
*pH	Within the range of 7.5 to 10.0 at all times	

NSPS
Lead-Tin-Bismuth Forming
Continuous Strip Casting Contact Cooling Water

Pollutant or pollutant property	Maximum for any one day	Maximum for monthly average
mg/off-kg (lb/million off-lbs) of lead-tin-bismuth cast by the continuous strip method		
*Antimony	.0029	.0013
*Lead	.0004	.0002
*Oil and Grease	.0200	.0120
*TSS	.0410	.0195
*pH	Within the range of 7.5 to 10.0 at all times	

Table XI-2 (Continued)

LEAD-TIN-BISMUTH FORMING SUBCATEGORY
NEW SOURCE PERFORMANCE STANDARDS

NSPS
Lead-Tin-Bismuth Forming
Semi-Continuous Ingot Casting Contact Cooling Water

Pollutant or pollutant property	Maximum for any one day	Maximum for monthly average
mg/off-kg (lb/million off-lbs) of lead-tin-bismuth ingot cast by the semi-continuous method		
*Antimony	.008	.004
*Lead	.001	.001
*Oil and Grease	.059	.035
*TSS	.121	.057
*pH	Within the range of 7.5 to 10.0 at all times	

NSPS
Lead-Tin-Bismuth Forming
Shot Casting Contact Cooling Water

Pollutant or pollutant property	Maximum for any one day	Maximum for monthly average
mg/off-kg (lb/million off-lbs) of lead-tin-bismuth shot cast		
*Antimony	.107	.048
*Lead	.016	.007
*Oil and Grease	.746	.448
*TSS	1.530	.728
*pH	Within the range of 7.5 to 10.0 at all times	

Table XI-2 (Continued)

LEAD-TIN-BISMUTH FORMING SUBCATEGORY
NEW SOURCE PERFORMANCE STANDARDS

NSPS

Lead-Tin-Bismuth Forming

Shot-Forming-Wet Air Pollution Control Blowdown

Pollutant or pollutant property	Maximum for any one day	Maximum for monthly average
mg/off-kg (lb/million off-lbs) of lead-tin-bismuth shot formed		
*Antimony	.169	.075
*Lead	.025	.012
*Oil and Grease	1.180	.706
*TSS	2.410	1.150
*pH	Within the range of 7.5 to 10.0 at all times	

NSPS

Lead-Tin-Bismuth Forming

Alkaline Cleaning Spent Baths

Pollutant or pollutant property	Maximum for any one day	Maximum for monthly average
mg/off-kg (lb/million off-lbs) of lead-tin-bismuth alkaline cleaned		
*Antimony	.345	.154
*Lead	.050	.024
*Oil and Grease	2.400	1.440
*TSS	4.920	2.340
*pH	Within the range of 7.5 to 10.0 at all times	

Table XI-2 (Continued)

LEAD-TIN-BISMUTH FORMING SUBCATEGORY
NEW SOURCE PERFORMANCE STANDARDS

NSPS

Lead-Tin-Bismuth Forming
Alkaline Cleaning Rinse

Pollutant or pollutant property	Maximum for any one day	Maximum for monthly average
mg/off-kg (lb/million off-lbs) of lead-tin-bismuth alkaline cleaned		
*Antimony	.678	.302
*Lead	.099	.047
*Oil and Grease	4.720	2.830
*TSS	9.680	4.600
*pH	Within the range of 7.5 to 10.0 at all times	

NSPS

Lead-Tin-Bismuth Forming
Degreasing Spent Solvents

There shall be no discharge of process wastewater
pollutants.

Table XI-3

MAGNESIUM FORMING SUBCATEGORY
NEW SOURCE PERFORMANCE STANDARDS

NSPS
Magnesium Forming
Rolling Spent Emulsions

Pollutant or pollutant property	Maximum for any one day	Maximum for monthly average
mg/off-kg (lb/million off-lbs) of magnesium rolled with emulsions		
*Chromium	.028	.011
*Zinc	.076	.031
*Ammonia	9.950	4.370
*Fluoride	4.440	1.970
Magnesium	.005	---
*Oil and Grease	.746	.746
*TSS	1.120	.895
*pH	Within the range of 7.5 to 10.0 at all times	

NSPS
Magnesium Forming
Forging Spent Lubricants

There shall be no discharge of process wastewater pollutants.

NSPS
Magnesium Forming
Forging Contact Cooling Water

Pollutant or pollutant property	Maximum for any one day	Maximum for monthly average
mg/off-kg (lb/million off-lbs) of forged magnesium cooled with water		
*Chromium	.107	.043
*Zinc	.295	.122
*Ammonia	38.500	17.000
*Fluoride	17.200	7.630
Magnesium	.019	---
*Oil and Grease	2.890	2.890
*TSS	4.340	3.470
*pH	Within the range of 7.5 to 10.0 at all times	

Table XI-3 (Continued)

MAGNESIUM FORMING SUBCATEGORY
NEW SOURCE PERFORMANCE STANDARDS

NSPS
Magnesium Forming
Forging Equipment Cleaning Wastewater

Pollutant or pollutant property	Maximum for any one day	Maximum for monthly average
mg/off-kg (lb/million off-lbs) of magnesium forged		
*Chromium	.0015	.0006
*Zinc	.0041	.0017
*Ammonia	.5320	.2340
*Fluoride	.2380	.1060
Magnesium	.0003	---
*Oil and Grease	.0399	.0399
*TSS	.0599	.0479
*pH	Within the range of 7.5 to 10.0 at all times	

NSPS
Magnesium Forming
Direct Chill Casting Contact Cooling Water

Pollutant or pollutant property	Maximum for any one day	Maximum for monthly average
mg/off-kg (lb/million off-lbs) of magnesium cast with direct chill methods		
*Chromium	1.460	.593
*Zinc	4.030	1.660
*Ammonia	527.000	232.000
*Fluoride	235.000	104.000
Magnesium	.265	---
*Oil and Grease	39.500	39.500
*TSS	59.300	47.400
*pH	Within the range of 7.5 to 10.0 at all times	

Table XI-3 (Continued)

MAGNESIUM FORMING SUBCATEGORY
NEW SOURCE PERFORMANCE STANDARDS

NSPS
Magnesium Forming
Surface Treatment Spent Baths

Pollutant or pollutant property	Maximum for any one day	Maximum for monthly average
mg/off-kg (lb/million off-lbs) of magnesium surface treated		
*Chromium	.173	.070
*Zinc	.476	.196
*Ammonia	62.100	27.300
*Fluoride	27.700	12.300
Magnesium	.031	---
*Oil and Grease	4.660	4.660
*TSS	6.990	5.590
*pH	Within the range of 7.5 to 10.0 at all times	

NSPS
Magnesium Forming
Surface Treatment Rinse

Pollutant or pollutant property	Maximum for any one day	Maximum for monthly average
mg/off-kg (lb/million off-lbs) of magnesium surface treated		
*Chromium	.700	.284
*Zinc	1.930	.794
*Ammonia	252.000	111.000
*Fluoride	113.000	49.900
Magnesium	.127	---
*Oil and Grease	18.900	18.900
*TSS	28.400	22.700
*pH	Within the range of 7.5 to 10.0 at all times	

Table XI-3 (Continued)

MAGNESIUM FORMING SUBCATEGORY
NEW SOURCE PERFORMANCE STANDARDS

NSPS
Magnesium Forming
Sawing or Grinding Spent Emulsions

Pollutant or pollutant property	Maximum for any one day	Maximum for monthly average
mg/off-kg (lb/million off-lbs) of magnesium sawed or ground		
*Chromium	.007	.003
*Zinc	.020	.008
*Ammonia	2.600	1.140
*Fluoride	1.160	.515
Magnesium	.001	---
*Oil and Grease	.195	.195
*TSS	.293	.234
*pH	Within the range of 7.5 to 10.0 at all times	

NSPS
Magnesium Forming
Degreasing Spent Solvents

There shall be no discharge of process wastewater
pollutants.

NSPS
Magnesium Forming
Wet Air Pollution Control Blowdown

Pollutant or pollutant property	Maximum for any one day	Maximum for monthly average
mg/off-kg (lb/million off-lbs) of magnesium formed		
*Chromium	.229	.093
*Zinc	.632	.260
*Ammonia	82.500	36.300
*Fluoride	36.900	16.400
Magnesium	.042	---
*Oil and Grease	6.190	6.190
*TSS	9.290	7.430
*pH	Within the range of 7.5 to 10.0 at all times	

Table XI-4

NICKEL-COBALT FORMING SUBCATEGORY
NEW SOURCE PERFORMANCE STANDARDS

NSPS
Nickel-Cobalt Forming
Rolling Spent Neat Oils

There shall be no discharge of process wastewater pollutants.

NSPS
Nickel-Cobalt Forming
Rolling Spent Emulsions

Pollutant or pollutant property	Maximum for any one day	Maximum for monthly average
mg/off-kg (lb/million off-lbs) of nickel-cobalt rolled with emulsions		
Cadmium	.034	.014
*Chromium	.063	.026
Copper	.218	.104
Lead	.048	.022
*Nickel	.094	.063
Zinc	.174	.071
*Fluoride	10.100	4.490
*Oil and Grease	1.700	1.700
*TSS	2.550	2.040
*pH	Within the range of 7.5 to 10.0 at all times	

Table XI-4 (Continued)

NICKEL-COBALT FORMING SUBCATEGORY
NEW SOURCE PERFORMANCE STANDARDS

NSPS
Nickel-Cobalt Forming
Rolling Contact Cooling Water

Pollutant or pollutant property	Maximum for any one day	Maximum for monthly average
mg/off-kg (lb/million off-lbs) of nickel-cobalt rolled with water		
Cadmium	.015	.006
*Chromium	.028	.011
Copper	.097	.046
Lead	.021	.010
*Nickel	.042	.028
Zinc	.077	.032
*Fluoride	4.490	1.990
*Oil and Grease	.754	.754
*TSS	1.130	.905
*pH	Within the range of 7.5 to 10.0 at all times	

NSPS
Nickel-Cobalt Forming
Tube Reducing Spent Lubricants

There shall be no discharge of process wastewater
pollutants.

NSPS
Nickel-Cobalt Forming
Drawing Spent Neat Oils

There shall be no discharge of process wastewater
pollutants.

Table XI-4 (Continued)

NICKEL-COBALT FORMING SUBCATEGORY
NEW SOURCE PERFORMANCE STANDARDS

NSPS
Nickel-Cobalt Forming
Drawing Spent Emulsions

Pollutant or pollutant property	Maximum for any one day	Maximum for monthly average
mg/off-kg (lb/million off-lbs) of nickel-cobalt drawn with emulsions		
Cadmium	.019	.008
*Chromium	.035	.014
Copper	.122	.058
Lead	.027	.012
*Nickel	.053	.035
Zinc	.097	.040
*Fluoride	5.680	2.520
*Oil and Grease	.954	.954
*TSS	1.430	1.150
*pH	Within the range of 7.5 to 10.0 at all times	

NSPS
Nickel-Cobalt Forming
Extrusion Spent Lubricants

There shall be no discharge of process wastewater
pollutants.

Table XI-4 (Continued)

NICKEL-COBALT FORMING SUBCATEGORY
NEW SOURCE PERFORMANCE STANDARDS

NSPS
Nickel-Cobalt Forming
Extrusion Press or Solution Heat Treatment Contact
Cooling Water

Pollutant or pollutant property	Maximum for any one day	Maximum for monthly average
mg/off-kg (lb/million off-lbs) of nickel-cobalt heat treated		
Cadmium	.017	.007
*Chromium	.031	.013
Copper	.107	.051
Lead	.023	.011
*Nickel	.046	.031
Zinc	.085	.035
*Fluoride	4.950	2.200
*Oil and Grease	.832	.832
*TSS	1.250	.999
*pH	Within the range of 7.5 to 10.0 at all times	

NSPS
Nickel-Cobalt Forming
Extrusion Press Hydraulic Fluid Leakage

Pollutant or pollutant property	Maximum for any one day	Maximum for monthly average
mg/off-kg (lb/million off-lbs) of nickel-cobalt extruded		
Cadmium	.046	.019
*Chromium	.086	.035
Copper	.297	.142
Lead	.065	.030
*Nickel	.128	.086
Zinc	.237	.098
*Fluoride	13.800	6.130
*Oil and Grease	2.320	2.320
*TSS	3.480	2.790
*pH	Within the range of 7.5 to 10.0 at all times	

Table XI-4 (Continued)

NICKEL-COBALT FORMING SUBCATEGORY
NEW SOURCE PERFORMANCE STANDARDS

NSPS
Nickel-Cobalt Forming
Forging Spent Lubricants

There shall be no discharge of process wastewater pollutants.

NSPS
Nickel-Cobalt Forming
Forging Contact Cooling Water

Pollutant or pollutant property	Maximum for any one day	Maximum for monthly average
mg/off-kg (lb/million off-lbs) of forged nickel-cobalt cooled with water		
Cadmium	.009	.004
*Chromium	.018	.007
Copper	.061	.029
Lead	.013	.006
*Nickel	.026	.018
Zinc	.048	.020
*Fluoride	2.820	1.250
*Oil and Grease	.474	.474
*TSS	.711	.569
*pH	Within the range of 7.5 to 10.0 at all times	

Table XI-4 (Continued)

NICKEL-COBALT FORMING SUBCATEGORY
NEW SOURCE PERFORMANCE STANDARDS

NSPS
Nickel-Cobalt Forming
Forging Equipment Cleaning Wastewater

Pollutant or pollutant property	Maximum for any one day	Maximum for monthly average
mg/off-kg (lb/million off-lbs) of nickel-cobalt forged		
Cadmium	.0008	.0003
*Chromium	.0015	.0006
Copper	.0051	.0024
Lead	.0011	.0005
*Nickel	.0022	.0015
Zinc	.0041	.0017
*Fluoride	.2380	.1060
*Oil and Grease	.0400	.0400
*TSS	.0600	.0480
*pH	Within the range of 7.5 to 10.0 at all times	

NSPS
Nickel-Cobalt Forming
Forging Press Hydraulic Fluid Leakage

Pollutant or pollutant property	Maximum for any one day	Maximum for monthly average
mg/off-kg (lb/million off-lbs) of nickel-cobalt forged		
Cadmium	.037	.015
*Chromium	.069	.028
Copper	.240	.114
Lead	.052	.024
*Nickel	.103	.069
Zinc	.191	.079
*Fluoride	11.100	4.940
*Oil and Grease	1.870	1.870
*TSS	2.810	2.250
*pH	Within the range of 7.5 to 10.0 at all times	

Table XI-4 (Continued)

NICKEL-COBALT FORMING SUBCATEGORY
NEW SOURCE PERFORMANCE STANDARDS

NSPS
Nickel-Cobalt Forming
Metal Powder Production Atomization Wastewater

Pollutant or pollutant property	Maximum for any one day	Maximum for monthly average
mg/off-kg (lb/million off-lbs) of nickel-cobalt metal powder atomized		
Cadmium	.524	.210
*Chromium	.970	.393
Copper	3.360	1.600
Lead	.734	.341
*Nickel	1.440	.970
Zinc	2.670	1.100
*Fluoride	156.000	69.200
*Oil and Grease	26.200	26.200
*TSS	39.300	31.500
*pH	Within the range of 7.5 to 10.0 at all times	

NSPS
Nickel-Cobalt Forming
Stationary Casting Contact Cooling Water

Pollutant or pollutant property	Maximum for any one day	Maximum for monthly average
mg/off-kg (lb/million off-lbs) of nickel-cobalt cast with stationary casting methods		
Cadmium	.242	.097
*Chromium	.448	.182
Copper	1.550	.738
Lead	.339	.158
*Nickel	.666	.448
Zinc	1.240	.508
*Fluoride	72.000	32.000
*Oil and Grease	12.100	12.100
*TSS	18.200	14.500
*pH	Within the range of 7.5 to 10.0 at all times	

Table XI-4 (Continued)

NICKEL-COBALT FORMING SUBCATEGORY
NEW SOURCE PERFORMANCE STANDARDS

NSPS
Nickel-Cobalt Forming
Vacuum Melting Steam Condensate

There shall be no allowance for the discharge of process wastewater pollutants.

NSPS
Nickel-Cobalt Forming
Annealing and Solution Heat Treatment Contact Cooling Water

There shall be no allowance for the discharge of process wastewater pollutants.

NSPS
Nickel-Cobalt Forming
Surface Treatment Spent Baths

Pollutant or pollutant property	Maximum for any one day	Maximum for monthly average
mg/off-kg (lb/million off-lbs) of nickel-cobalt surface treated		
Cadmium	.187	.075
*Chromium	.346	.140
Copper	1.200	.571
Lead	.262	.122
*Nickel	.514	.346
Zinc	.954	.393
*Fluoride	55.700	24.700
*Oil and Grease	9.350	9.350
*TSS	14.000	11.200
*pH	Within the range of 7.5 to 10.0 at all times	

Table XI-4 (Continued)

NICKEL-COBALT FORMING SUBCATEGORY
NEW SOURCE PERFORMANCE STANDARDS

NSPS

Nickel-Cobalt Forming
Surface Treatment Rinse

Pollutant or pollutant property	Maximum for any one day	Maximum for monthly average
mg/off-kg (lb/million off-lbs) of nickel-cobalt surface treated		
Cadmium	.472	.189
*Chromium	.873	.354
Copper	3.020	1.440
Lead	.661	.307
*Nickel	1.300	.873
Zinc	2.410	.991
*Fluoride	141.000	62.300
*Oil and Grease	23.600	23.600
*TSS	35.400	28.300
*pH	Within the range of 7.5 to 10.0 at all times	

NSPS

Nickel-Cobalt Forming
Ammonia Rinse

Pollutant or pollutant property	Maximum for any one day	Maximum for monthly average
mg/off-kg (lb/million off-lbs) of nickel-cobalt treated with ammonia solution		
Cadmium	.003	.001
*Chromium	.005	.002
Copper	.019	.009
Lead	.004	.002
*Nickel	.008	.005
Zinc	.015	.006
*Fluoride	.881	.391
*Oil and Grease	.148	.148
*TSS	.222	.178
*pH	Within the range of 7.5 to 10.0 at all times	

Table XI-4 (Continued)

NICKEL-COBALT FORMING SUBCATEGORY
NEW SOURCE PERFORMANCE STANDARDS

NSPS
Nickel-Cobalt Forming
Alkaline Cleaning Spent Baths

Pollutant or pollutant property	Maximum for any one day	Maximum for monthly average
mg/off-kg (lb/million off-lbs) of nickel-cobalt alkaline cleaned		
Cadmium	.007	.003
*Chromium	.013	.005
Copper	.043	.021
Lead	.009	.004
*Nickel	.019	.013
Zinc	.035	.014
*Fluoride	2.020	.895
*Oil and Grease	.339	.339
*TSS	.509	.407
*pH	Within the range of 7.5 to 10.0 at all times	

NSPS
Nickel-Cobalt Forming
Alkaline Cleaning Rinse

Pollutant or pollutant property	Maximum for any one day	Maximum for monthly average
mg/off-kg (lb/million off-lbs) of nickel-cobalt alkaline cleaned		
Cadmium	.047	.019
*Chromium	.086	.035
Copper	.298	.142
Lead	.065	.030
*Nickel	.128	.086
Zinc	.238	.098
*Fluoride	13.900	6.150
*Oil and Grease	2.330	2.330
*TSS	3.500	2.800
*pH	Within the range of 7.5 to 10.0 at all times	

Table XI-4 (Continued)

NICKEL-COBALT FORMING SUBCATEGORY
NEW SOURCE PERFORMANCE STANDARDS

NSPS
Nickel-Cobalt Forming
Molten Salt Rinse

Pollutant or pollutant property	Maximum for any one day	Maximum for monthly average
mg/off-kg (lb/million off-lbs) of nickel-cobalt treated with molten salt		
Cadmium	.169	.068
*Chromium	.312	.127
Copper	1.080	.515
Lead	.237	.110
*Nickel	.464	.312
Zinc	.861	.355
*Fluoride	50.200	22.300
*Oil and Grease	8.440	8.440
*TSS	12.700	10.100
*pH	Within the range of 7.5 to 10.0 at all times	

NSPS
Nickel-Cobalt Forming
Sawing or Grinding Spent Emulsions

Pollutant or pollutant property	Maximum for any one day	Maximum for monthly average
mg/off-kg (lb/million off-lbs) of nickel-cobalt sawed or ground with emulsions		
Cadmium	.008	.003
*Chromium	.015	.006
Copper	.051	.024
Lead	.011	.005
*Nickel	.022	.015
Zinc	.040	.017
*Fluoride	2.350	1.040
*Oil and Grease	.394	.394
*TSS	.591	.473
*pH	Within the range of 7.5 to 10.0 at all times	

Table XI-4 (Continued)

NICKEL-COBALT FORMING SUBCATEGORY
NEW SOURCE PERFORMANCE STANDARDS

NSPS
Nickel-Cobalt Forming
Sawing or Grinding Rinse

Pollutant or pollutant property	Maximum for any one day	Maximum for monthly average
mg/off-kg (lb/million off-lbs) of sawed or ground nickel-cobalt rinsed		
Cadmium	.036	.015
*Chromium	.067	.027
Copper	.232	.111
Lead	.051	.024
*Nickel	.100	.067
Zinc	.185	.076
*Fluoride	10.800	4.780
*Oil and Grease	1.810	1.810
*TSS	2.720	2.170
*pH	Within the range of 7.5 to 10.0 at all times	

NSPS
Nickel-Cobalt Forming
Steam Cleaning Condensate

Pollutant or pollutant property	Maximum for any one day	Maximum for monthly average
mg/off-kg (lb/million off-lbs) of nickel-cobalt steam cleaned		
Cadmium	.006	.002
*Chromium	.011	.005
Copper	.039	.018
Lead	.008	.004
*Nickel	.017	.011
Zinc	.031	.013
*Fluoride	1.790	.795
*Oil and Grease	.301	.301
*TSS	.452	.361
*pH	Within the range of 7.5 to 10.0 at all times	

Table XI-4 (Continued)

NICKEL-COBALT FORMING SUBCATEGORY
NEW SOURCE PERFORMANCE STANDARDS

NSPS

Nickel-Cobalt Forming
Hydrostatic Tube Testing and Ultrasonic Testing Wastewater

There shall be no allowance for the discharge of
process wastewater pollutants.

NSPS

Nickel-Cobalt Forming
Dye Penetrant Testing Wastewater

Pollutant or pollutant property	Maximum for any one day	Maximum for monthly average
mg/off-kg (lb/million off-lbs) of nickel-cobalt tested with dye penetrant methods		
Cadmium	.043	.017
*Chromium	.079	.032
Copper	.273	.130
Lead	.060	.028
*Nickel	.117	.079
Zinc	.217	.090
*Fluoride	12.700	5.630
*Oil and Grease	2.130	2.130
*TSS	3.200	2.560
*pH	Within the range of 7.5 to 10.0 at all times	

Table XI-4 (Continued)

NICKEL-COBALT FORMING SUBCATEGORY
NEW SOURCE PERFORMANCE STANDARDS

NSPS
Nickel-Cobalt Forming
Miscellaneous Wastewater Sources

Pollutant or pollutant property	Maximum for any one day	Maximum for monthly average
mg/off-kg (lb/million off-lbs) of nickel-cobalt formed		
Cadmium	.049	.020
*Chromium	.091	.037
Copper	.315	.150
Lead	.069	.032
*Nickel	.136	.091
Zinc	.251	.104
*Fluoride	14.700	6.500
*Oil and Grease	2.460	2.460
*TSS	3.690	2.950
*pH	Within the range of 7.5 to 10.0 at all times	

NSPS
Nickel-Cobalt Forming
Degreasing Spent Solvents

There shall be no discharge of process wastewater
pollutants.

Table XI-4 (Continued)

NICKEL-COBALT FORMING SUBCATEGORY
NEW SOURCE PERFORMANCE STANDARDS

NSPS

Nickel-Cobalt Forming

Wet Air Pollution Control Blowdown

Pollutant or pollutant property	Maximum for any one day	Maximum for monthly average
mg/off-kg (lb/million off-lbs) of nickel-cobalt formed		
Cadmium	.162	.065
*Chromium	.300	.122
Copper	1.040	.494
Lead	.227	.106
*Nickel	.446	.300
Zinc	.826	.340
*Fluoride	48.200	21.400
*Oil and Grease	8.100	8.100
*TSS	12.200	9.720
*pH	Within the range of 7.5 to 10.0 at all times	

NSPS

Nickel-Cobalt Forming

Electrocoating Rinse

Pollutant or pollutant property	Maximum for any one day	Maximum for monthly average
mg/off-kg (lb/million off-lbs) of nickel-cobalt electrocoated		
Cadmium	.674	.270
*Chromium	1.250	.506
Copper	4.320	2.060
Lead	.944	.438
*Nickel	1.860	1.250
Zinc	3.440	1.420
*Fluoride	201.000	89.000
*Oil and Grease	33.700	33.700
*TSS	50.600	40.500
*pH	Within the range of 7.5 to 10.0 at all times	

Table XI-5

PRECIOUS METALS FORMING SUBCATEGORY
NEW SOURCE PERFORMANCE STANDARDS

NSPS
Precious Metals Forming
Rolling Spent Neat Oils

There shall be no discharge of process wastewater pollutants.

NSPS
Precious Metals Forming
Rolling Spent Emulsions

Pollutant or pollutant property	Maximum for any one day	Maximum for monthly average
mg/off-kg (lb/million off-lbs) of precious metals rolled with emulsions		
*Cadmium	.026	.012
Chromium	.034	.014
*Copper	.147	.077
*Cyanide	.022	.009
*Lead	.032	.015
Nickel	.148	.098
*Silver	.032	.013
Zinc	.113	.047
*Oil and Grease	1.540	.925
*TSS	3.160	1.510
*pH	Within the range of 7.5 to 10.0 at all times	

NSPS
Precious Metals Forming
Drawing Spent Neat Oils

There shall be no discharge of process wastewater pollutants.

Table XI-5 (Continued)

PRECIOUS METALS FORMING SUBCATEGORY
NEW SOURCE PERFORMANCE STANDARDS

NSPS
Precious Metals Forming
Drawing Spent Emulsions

Pollutant or pollutant property	Maximum for any one day	Maximum for monthly average
mg/off-kg (lb/million off-lbs) of precious metals drawn with emulsions		
*Cadmium	.016	.007
Chromium	.021	.009
*Copper	.090	.048
*Cyanide	.014	.006
*Lead	.020	.010
Nickel	.091	.060
*Silver	.020	.008
Zinc	.069	.029
*Oil and Grease	.950	.570
*TSS	1.950	.926
*pH	Within the range of 7.5 to 10.0 at all times	

NSPS
Precious Metals Forming
Drawing Spent Soap Solutions

Pollutant or pollutant property	Maximum for any one day	Maximum for monthly average
mg/off-kg (lb/million off-lbs) of precious metals drawn with soap solutions		
*Cadmium	.0011	.0005
Chromium	.0014	.0006
*Copper	.0059	.0031
*Cyanide	.0009	.0004
*Lead	.0013	.0006
Nickel	.0060	.0040
*Silver	.0013	.0005
Zinc	.0046	.0019
*Oil and Grease	.0624	.0375
*TSS	.1280	.0609
*pH	Within the range of 7.5 to 10.0 at all times	

Table XI-5 (Continued)

PRECIOUS METALS FORMING SUBCATEGORY
NEW SOURCE PERFORMANCE STANDARDS

NSPS
Precious Metals Forming
Metal Powder Production Atomization Wastewater

Pollutant or pollutant property	Maximum for any one day	Maximum for monthly average
mg/off-kg (lb/million off-lbs) of precious metals powder wet atomized		
*Cadmium	2.270	1.000
Chromium	2.940	1.200
*Copper	12.700	6.680
*Cyanide	1.940	.802
*Lead	2.810	1.340
Nickel	12.800	8.490
*Silver	2.740	1.140
Zinc	9.750	4.080
*Oil and Grease	134.000	80.200
*TSS	274.000	130.000
*pH	Within the range of 7.5 to 10.0 at all times	

NSPS
Precious Metals Forming
Direct Chill Casting Contact Cooling Water

Pollutant or pollutant property	Maximum for any one day	Maximum for monthly average
mg/off-kg (lb/million off-lbs) of precious metals cast by the direct chill method		
*Cadmium	.367	.162
Chromium	.475	.195
*Copper	2.050	1.080
*Cyanide	.313	.130
*Lead	.454	.216
Nickel	2.080	1.370
*Silver	.443	.184
Zinc	1.580	.659
*Oil and Grease	21.600	13.000
*TSS	44.300	21.100
*pH	Within the range of 7.5 to 10.0 at all times	

Table XI-5 (Continued)

PRECIOUS METALS FORMING SUBCATEGORY
NEW SOURCE PERFORMANCE STANDARDS

NSPS
Precious Metals Forming
Shot Casting Contact Cooling Water

Pollutant or pollutant property	Maximum for any one day	Maximum for monthly average
mg/off-kg (lb/million off-lbs) of precious metals shot cast		
*Cadmium	.125	.055
Chromium	.162	.066
*Copper	.698	.367
*Cyanide	.107	.044
*Lead	.154	.073
Nickel	.705	.466
*Silver	.151	.062
Zinc	.536	.224
*Oil and Grease	7.340	4.410
*TSS	15.100	7.160
*pH	Within the range of 7.5 to 10.0 at all times	

NSPS
Precious Metals Forming
Stationary Casting Contact Cooling Water

There shall be no discharge of process wastewater
pollutants.

Table XI-5 (Continued)

PRECIOUS METALS FORMING SUBCATEGORY
NEW SOURCE PERFORMANCE STANDARDS

NSPS
Precious Metals Forming
Semi-Continuous and Continuous Casting Contact
Cooling Water

Pollutant or pollutant property	Maximum for any one day	Maximum for monthly average
mg/off-kg (lb/million off-lbs) of precious metals cast by the semi-continuous or continuous method		
*Cadmium	.350	.155
Chromium	.453	.186
*Copper	1.960	1.030
*Cyanide	.299	.124
*Lead	.433	.206
Nickel	1.980	1.310
*Silver	.423	.175
Zinc	1.510	.629
*Oil and Grease	20.600	12.400
*TSS	42.300	20.100
*pH	Within the range of 7.5 to 10.0 at all times	

NSPS
Precious Metals Forming
Heat Treatment Contact Cooling Water

Pollutant or pollutant property	Maximum for any one day	Maximum for monthly average
mg/off-kg (lb/million off-lbs) of extruded precious metals heat treated		
*Cadmium	.142	.063
Chromium	.184	.075
*Copper	.793	.417
*Cyanide	.121	.050
*Lead	.175	.083
Nickel	.801	.530
*Silver	.171	.071
Zinc	.609	.255
*Oil and Grease	8.340	5.010
*TSS	17.100	8.130
*pH	Within the range of 7.5 to 10.0 at all times	

Table XI-5 (Continued)

PRECIOUS METALS FORMING SUBCATEGORY
NEW SOURCE PERFORMANCE STANDARDS

NSPS
Precious Metals Forming
Surface Treatment Spent Baths

Pollutant or pollutant property	Maximum for any one day	Maximum for monthly average
mg/off-kg (lb/million off-lbs) of precious metals surface treated		
*Cadmium	.033	.015
Chromium	.042	.017
*Copper	.183	.096
*Cyanide	.028	.012
*Lead	.041	.019
Nickel	.185	.123
*Silver	.040	.016
Zinc	.141	.059
*Oil and Grease	1.930	1.160
*TSS	3.950	1.880
*pH	Within the range of 7.5 to 10.0 at all times	

NSPS
Precious Metals Forming
Surface Treatment Rinse

Pollutant or pollutant property	Maximum for any one day	Maximum for monthly average
mg/off-kg (lb/million off-lbs) of precious metals surface treated		
*Cadmium	.210	.092
Chromium	.271	.111
*Copper	1.170	.616
*Cyanide	.179	.074
*Lead	.259	.123
Nickel	1.180	.783
*Silver	.253	.105
Zinc	.900	.376
*Oil and Grease	12.300	7.390
*TSS	25.300	12.000
*pH	Within the range of 7.5 to 10.0 at all times	

Table XI-5 (Continued)

PRECIOUS METALS FORMING SUBCATEGORY
NEW SOURCE PERFORMANCE STANDARDS

NSPS
Precious Metals Forming
Alkaline Cleaning Spent Baths

Pollutant or pollutant property	Maximum for any one day	Maximum for monthly average
mg/off-kg (lb/million off-lbs) of precious metals alkaline cleaned		
*Cadmium	.020	.009
Chromium	.026	.011
*Copper	.114	.060
*Cyanide	.017	.007
*Lead	.025	.012
Nickel	.115	.076
*Silver	.025	.010
Zinc	.088	.037
*Oil and Grease	1.200	.720
*TSS	2.460	1.170
*pH	Within the range of 7.5 to 10.0 at all times	

NSPS
Precious Metals Forming
Alkaline Cleaning Rinse

Pollutant or pollutant property	Maximum for any one day	Maximum for monthly average
mg/off-kg (lb/million off-lbs) of precious metals alkaline cleaned		
*Cadmium	.381	.168
Chromium	.493	.202
*Copper	2.130	1.120
*Cyanide	.325	.135
*Lead	.471	.224
Nickel	2.150	1.420
*Silver	.459	.191
Zinc	1.640	.683
*Oil and Grease	22.400	13.500
*TSS	45.900	21.900
*pH	Within the range of 7.5 to 10.0 at all times	

Table XI-5 (Continued)

PRECIOUS METALS FORMING SUBCATEGORY
NEW SOURCE PERFORMANCE STANDARDS

NSPS

Precious Metals Forming
Alkaline Cleaning Prebonding Wastewater

Pollutant or pollutant property	Maximum for any one day	Maximum for monthly average
mg/off-kg (lb/million off-lbs) of precious metals and base metal cleaned prior to bonding		
*Cadmium	.395	.174
Chromium	.511	.209
*Copper	2.210	1.160
*Cyanide	.337	.139
*Lead	.487	.232
Nickel	2.230	1.480
*Silver	.476	.197
Zinc	1.700	.708
*Oil and Grease	23.200	13.900
*TSS	47.600	22.600
*pH	Within the range of 7.5 to 10.0 at all times	

NSPS

Precious Metals Forming
Tumbling or Burnishing Wastewater

Pollutant or pollutant property	Maximum for any one day	Maximum for monthly average
mg/off-kg (lb/million off-lbs) of precious metals tumbled or burnished		
*Cadmium	.412	.182
Chromium	.533	.218
*Copper	2.300	1.210
*Cyanide	.351	.145
*Lead	.508	.242
Nickel	2.330	1.540
*Silver	.496	.206
Zinc	1.770	.738
*Oil and Grease	24.200	14.500
*TSS	49.600	23.600
*pH	Within the range of 7.5 to 10.0 at all times	

Table XI-5 (Continued)

PRECIOUS METALS FORMING SUBCATEGORY
NEW SOURCE PERFORMANCE STANDARDS

NSPS
Precious Metals Forming
Sawing or Grinding Spent Neat Oils

There shall be no discharge of process wastewater pollutants.

NSPS
Precious Metals Forming
Sawing or Grinding Spent Emulsions

Pollutant or pollutant property	Maximum for any one day	Maximum for monthly average
mg/off-kg (lb/million off-lbs) of precious metals sawed or ground with emulsions		
*Cadmium	.032	.014
Chromium	.041	.017
*Copper	.178	.093
*Cyanide	.027	.011
*Lead	.039	.019
Nickel	.180	.119
*Silver	.038	.016
Zinc	.137	.057
*Oil and Grease	1.870	1.120
*TSS	3.830	1.820
*pH	Within the range of 7.5 to 10.0 at all times	

Table XI-5 (Continued)

PRECIOUS METALS FORMING SUBCATEGORY
NEW SOURCE PERFORMANCE STANDARDS

NSPS
Precious Metals Forming
Pressure Bonding Contact Cooling Water

Pollutant or pollutant property	Maximum for any one day	Maximum for monthly average
mg/off-kg (lb/million off-lbs) of precious metals and base metal pressure bonded		
*Cadmium	.028	.013
Chromium	.037	.015
*Copper	.159	.084
*Cyanide	.024	.010
*Lead	.035	.017
Nickel	.161	.106
*Silver	.034	.014
Zinc	.122	.051
*Oil and Grease	1.670	1.000
*TSS	3.430	1.630
*pH	Within the range of 7.5 to 10.0 at all times	

NSPS
Precious Metals Forming
Degreasing Spent Solvents

There shall be no discharge of process wastewater
pollutants.

NSPS
Precious Metals Forming
Wet Air Pollution Control Blowdown

There shall be no discharge of process wastewater
pollutants.

Table XI-6

REFRACTORY METALS FORMING SUBCATEGORY
NEW SOURCE PERFORMANCE STANDARDS

NSPS

Refractory Metals Forming
Rolling Spent Neat Oils and Graphite-Based Lubricants

There shall be no discharge of process wastewater pollutants.

NSPS

Refractory Metals Forming
Rolling Spent Emulsions

Pollutant or pollutant property	Maximum for any one day	Maximum for monthly average
mg/off-kg (lb/million off-lbs) of refractory metals rolled with emulsions		
*Chromium	.159	.064
*Copper	.549	.262
Lead	.120	.056
*Nickel	.236	.159
Silver	.125	.052
Zinc	.438	.180
Columbium	.052	---
*Fluoride	25.500	11.300
*Molybdenum	2.160	.957
Tantalum	.193	---
Vanadium	.043	---
Tungsten	1.490	.665
*Oil and Grease	4.290	4.290
*TSS	6.440	5.150
*pH	Within the range of 7.5 to 10.0 at all times	

NSPS

Refractory Metals Forming
Drawing Spent Lubricants

There shall be no discharge of process wastewater pollutants.

Table XI-6 (Continued)

REFRACTORY METALS FORMING SUBCATEGORY
NEW SOURCE PERFORMANCE STANDARDS

NSPS
Refractory Metals Forming
Extrusion Spent Lubricants

There shall be no discharge of process wastewater pollutants.

NSPS
Refractory Metals Forming
Extrusion Press Hydraulic Fluid Leakage

Pollutant or pollutant property	Maximum for any one day	Maximum for monthly average
------------------------------------	----------------------------	--------------------------------

mg/off-kg (lb/million off-lbs) of refractory metals
extruded

Chromium	.441	.179
*Copper	1.530	.726
Lead	.333	.155
*Nickel	.655	.441
Silver	.345	.143
Zinc	1.220	.500
Columbium	.143	---
*Fluoride	70.800	31.400
*Molybdenum	5.990	2.660
Tantalum	.536	---
Vanadium	.119	---
Tungsten	4.140	1.850
*Oil and Grease	11.900	11.900
*TSS	17.900	14.300
*pH	Within the range of 7.5 to 10.0 at all times	

NSPS
Refractory Metals Forming
Forging Spent Lubricants

There shall be no discharge of process wastewater pollutants.

Table XI-6 (Continued)

REFRACTORY METALS FORMING SUBCATEGORY
NEW SOURCE PERFORMANCE STANDARDS

NSPS

Refractory Metals Forming
Forging Contact Cooling Water

Pollutant or pollutant property	Maximum for any one day	Maximum for monthly average
mg/off-kg (lb/million off-lbs) of forged refractory metals cooled with water		
Chromium	.012	.005
*Copper	.041	.020
Lead	.009	.004
*Nickel	.018	.012
Silver	.009	.004
Zinc	.033	.014
Columbium	.004	---
*Fluoride	1.920	.853
*Molybdenum	.163	.072
Tantalum	.015	---
Vanadium	.003	---
Tungsten	.113	.050
*Oil and Grease	.323	.323
*TSS	.485	.388
*pH	Within the range of 7.5 to 10.0 at all times	

Table XI-6 (Continued)

REFRACTORY METALS FORMING SUBCATEGORY
NEW SOURCE PERFORMANCE STANDARDS

NSPS

Refractory Metals Forming
Metal Powder Production Wastewater

Pollutant or pollutant property	Maximum for any one day	Maximum for monthly average
mg/off-kg (lb/million off-lbs) of refractory metals powder produced		
Chromium	.104	.042
*Copper	.360	.172
Lead	.079	.037
*Nickel	.155	.104
Silver	.082	.034
Zinc	.287	.118
Columbium	.034	---
*Fluoride	16.700	7.420
*Molybdenum	1.420	.627
Tantalum	.127	---
Vanadium	.028	---
Tungsten	.978	.436
*Oil and Grease	2.810	2.810
*TSS	4.220	3.370
*pH	Within the range of 7.5 to 10.0 at all times	

NSPS

Refractory Metals Forming
Metal Powder Production Floor Wash Water

There shall be no discharge of process wastewater
pollutants.

NSPS

Refractory Metals Forming
Metal Powder Pressing Spent Lubricants

There shall be no discharge of process wastewater
pollutants.

Table XI-6 (Continued)

REFRACTORY METALS FORMING SUBCATEGORY
NEW SOURCE PERFORMANCE STANDARDS

NSPS
Refractory Metals Forming
Surface Treatment Spent Baths

Pollutant or pollutant property	Maximum for any one day	Maximum for monthly average
mg/off-kg (lb/million off-lbs) of refractory metals surface treated		
Chromium	.144	.058
*Copper	.498	.237
Lead	.109	.051
*Nickel	.214	.144
Silver	.113	.047
Zinc	.397	.164
Columbium	.047	---
*Fluoride	23.200	10.300
*Molybdenum	1.960	.868
Tantalum	.175	---
Vanadium	.039	---
Tungsten	1.360	.603
*Oil and Grease	3.890	3.890
*TSS	5.840	4.670
*pH	Within the range of 7.5 to 10.0 at all times	

Table XI-6 (Continued)

REFRACTORY METALS FORMING SUBCATEGORY
NEW SOURCE PERFORMANCE STANDARDS

NSPS

Refractory Metals Forming
Surface Treatment Rinse

Pollutant or pollutant property	Maximum for any one day	Maximum for monthly average
mg/off-kg (lb/million off-lbs) of refractory metals surface treated		
Chromium	4.480	1.820
*Copper	15.500	7.380
Lead	3.390	1.580
*Nickel	6.660	4.480
Silver	3.510	1.450
Zinc	12.400	5.080
Columbium	1.450	---
*Fluoride	720.000	320.000
*Molybdenum	60.900	27.000
Tantalum	5.450	---
Vanadium	1.210	---
Tungsten	42.100	18.800
*Oil and Grease	121.000	121.000
*TSS	182.000	145.000
*pH	Within the range of 7.5 to 10.0 at all times	

Table XI-6 (Continued)

REFRACTORY METALS FORMING SUBCATEGORY
NEW SOURCE PERFORMANCE STANDARDS

NSPS

Refractory Metals Forming
Alkaline Cleaning Spent Baths

Pollutant or pollutant property	Maximum for any one day	Maximum for monthly average
mg/off-kg (lb/million off-lbs) of refractory metals alkaline cleaned		
Chromium	.124	.050
*Copper	.428	.204
Lead	.094	.043
*Nickel	.184	.124
Silver	.097	.040
Zinc	.341	.140
Columbium	.040	---
*Fluoride	19.900	8.820
*Molybdenum	1.680	.745
Tantalum	.151	---
Vanadium	.033	---
Tungsten	1.160	.518
*Oil and Grease	3.340	3.340
*TSS	5.010	4.010
*pH	Within the range of 7.5 to 10.0 at all times	

Table XI-6 (Continued)

REFRACTORY METALS FORMING SUBCATEGORY
NEW SOURCE PERFORMANCE STANDARDS

NSPS

Refractory Metals Forming
Alkaline Cleaning Rinse

Pollutant or pollutant property	Maximum for any one day	Maximum for monthly average
mg/off-kg (lb/million off-lbs) of refractory metals alkaline cleaned		
Chromium	3.020	1.230
*Copper	10.500	4.980
Lead	2.290	1.060
*Nickel	4.490	3.020
Silver	2.370	.979
Zinc	8.330	3.430
Columbium	.979	---
*Fluoride	486.000	216.000
*Molybdenum	41.100	18.200
Tantalum	3.670	---
Vanadium	.816	---
Tungsten	28.400	12.700
*Oil and Grease	81.600	81.600
*TSS	123.000	97.900
*pH	Within the range of 7.5 to 10.0 at all times	

Table XI-6 (Continued)

REFRACTORY METALS FORMING SUBCATEGORY
NEW SOURCE PERFORMANCE STANDARDSNSPS
Refractory Metals Forming
Molten Salt Rinse

Pollutant or pollutant property	Maximum for any one day	Maximum for monthly average
mg/off-kg (lb/million off-lbs) of refractory metals treated with molten salt		
Chromium	.234	.095
*Copper	.810	.386
Lead	.177	.082
*Nickel	.348	.234
Silver	.184	.076
Zinc	.646	.266
Columbium	.076	---
*Fluoride	37.700	16.700
*Molybdenum	3.190	1.410
Tantalum	.285	---
Vanadium	.063	---
Tungsten	2.200	.981
*Oil and Grease	6.330	6.330
*TSS	9.500	7.600
*pH	Within the range of 7.5 to 10.0 at all times	

Table XI-6 (Continued)

REFRACTORY METALS FORMING SUBCATEGORY
NEW SOURCE PERFORMANCE STANDARDS

NSPS
Refractory Metals Forming
Tumbling or Burnishing Wastewater

Pollutant or pollutant property	Maximum for any one day	Maximum for monthly average
mg/off-kg (lb/million off-lbs) of refractory metals tumbled or burnished		
Chromium	.463	.188
*Copper	1.600	.763
Lead	.350	.163
*Nickel	.688	.463
Silver	.363	.150
Zinc	1.280	.525
Columbium	.150	---
*Fluoride	74.400	33.000
*Molybdenum	6.290	2.790
Tantalum	.563	---
Vanadium	.125	---
Tungsten	4.350	1.940
*Oil and Grease	12.500	12.500
*TSS	18.800	15.000
*pH	Within the range of 7.5 to 10.0 at all times	

NSPS
Refractory Metals Forming
Sawing or Grinding Spent Neat Oils

There shall be no discharge of process wastewater
pollutants.

Table XI-6 (Continued)

REFRACTORY METALS FORMING SUBCATEGORY
NEW SOURCE PERFORMANCE STANDARDS

NSPS
Refractory Metals Forming
Sawing or Grinding Spent Emulsions

Pollutant or pollutant property	Maximum for any one day	Maximum for monthly average
mg/off-kg (lb/million off-lbs) of refractory metals sawed or ground with emulsions		
Chromium	.110	.045
*Copper	.380	.181
Lead	.083	.039
*Nickel	.164	.110
Silver	.086	.036
Zinc	.303	.125
Columbium	.036	---
*Fluoride	17.700	7.840
*Molybdenum	1.500	.663
Tantalum	.134	---
Vanadium	.030	---
Tungsten	1.040	.461
*Oil and Grease	2.970	2.970
*TSS	4.460	3.570
*pH	Within the range of 7.5 to 10.0 at all times	

Table XI-6 (Continued)

REFRACTORY METALS FORMING SUBCATEGORY
NEW SOURCE PERFORMANCE STANDARDS

NSPS
Refractory Metals Forming
Sawing or Grinding Contact Cooling Water

Pollutant or pollutant property	Maximum for any one day	Maximum for monthly average
mg/off-kg (lb/million off-lbs) of refractory metals sawed or ground with contact cooling water		
Chromium	.899	.365
*Copper	3.110	1.480
Lead	.681	.316
*Nickel	1.340	.899
Silver	.705	.292
Zinc	2.480	1.020
Columbium	.292	---
*Fluoride	145.000	64.200
*Molybdenum	12.200	5.420
Tantalum	1.100	---
Vanadium	.243	---
Tungsten	8.460	3.770
*Oil and Grease	24.300	24.300
*TSS	36.500	29.200
*pH	Within the range of 7.5 to 10.0 at all times	

Table XI-6 (Continued)

REFRACTORY METALS FORMING SUBCATEGORY
NEW SOURCE PERFORMANCE STANDARDS

NSPS
Refractory Metals Forming
Sawing or Grinding Rinse

Pollutant or pollutant property	Maximum for any one day	Maximum for monthly average
mg/off-kg (lb/million off-lbs) of sawed or ground refractory metals rinsed		
Chromium	.005	.002
*Copper	.017	.008
Lead	.004	.002
*Nickel	.007	.005
Silver	.004	.002
Zinc	.014	.006
Columbium	.002	---
*Fluoride	.803	.357
*Molybdenum	.068	.030
Tantalum	.006	---
Vanadium	.001	---
Tungsten	.047	.021
*Oil and Grease	.135	.135
*TSS	.203	.162
*pH	Within the range of 7.5 to 10.0 at all times	

Table XI-6 (Continued)

REFRACTORY METALS FORMING SUBCATEGORY
NEW SOURCE PERFORMANCE STANDARDS

NSPS

Refractory Metals Forming

Dye Penetrant Testing Wastewater

Pollutant or pollutant property	Maximum for any one day	Maximum for monthly average
mg/off-kg (lb/million off-lbs) of refractory metals tested with dye penetrant methods		
Chromium	.029	.012
*Copper	.099	.047
Lead	.022	.010
*Nickel	.043	.029
Silver	.023	.009
Zinc	.079	.033
Columbium	.009	---
*Fluoride	4.620	2.050
*Molybdenum	.391	.173
Tantalum	.035	---
Vanadium	.008	---
Tungsten	.270	.120
*Oil and Grease	.776	.776
*TSS	1.170	.931
*pH	Within the range of 7.5 to 10.0 at all times	

Table XI-6 (Continued)

REFRACTORY METALS FORMING SUBCATEGORY
NEW SOURCE PERFORMANCE STANDARDS

NSPS
Refractory Metals Forming
Equipment Cleaning Wastewater

Pollutant or pollutant property	Maximum for any one day	Maximum for monthly average
mg/off-kg (lb/million off-lbs) of refractory metals formed		
Chromium	.050	.020
*Copper	.174	.083
Lead	.038	.018
*Nickel	.075	.050
Silver	.040	.016
Zinc	.139	.057
Columbium	.016	---
*Fluoride	8.090	3.590
*Molybdenum	.684	.303
Tantalum	.061	---
Vanadium	.014	---
Tungsten	.473	.211
*Oil and Grease	1.360	1.360
*TSS	2.040	1.630
*pH	Within the range of 7.5 to 10.0 at all times	

Table XI-6 (Continued)

REFRACTORY METALS FORMING SUBCATEGORY
NEW SOURCE PERFORMANCE STANDARDS

NSPS
Refractory Metals Forming
Miscellaneous Wastewater Sources

Pollutant or pollutant property	Maximum for any one day	Maximum for monthly average
mg/off-kg (lb/million off-lbs) of refractory metals formed		
Chromium	.128	.052
*Copper	.442	.211
Lead	.097	.045
*Nickel	.190	.128
Silver	.100	.041
Zinc	.352	.145
Columbium	.041	---
*Fluoride	20.500	9.110
*Molybdenum	1.740	.770
Tantalum	.155	---
Vanadium	.035	---
Tungsten	1.200	.535
*Oil and Grease	3.450	3.450
*TSS	5.180	4.140
*pH	Within the range of 7.5 to 10.0 at all times	

NSPS
Refractory Metals Forming
Degreasing Spent Solvents

There shall be no discharge of process wastewater
pollutants.

Table XI-6 (Continued)

REFRACTORY METALS FORMING SUBCATEGORY
NEW SOURCE PERFORMANCE STANDARDS

NSPS

Refractory Metals Forming

Wet Air Pollution Control Blowdown

Pollutant or pollutant property	Maximum for any one day	Maximum for monthly average
mg/off-kg (lb/million off-lbs) of refractory metals formed		
Chromium	.291	.118
*Copper	1.010	.480
Lead	.221	.103
*Nickel	.433	.291
Silver	.228	.095
Zinc	.803	.331
Columbium	.095	---
*Fluoride	46.800	20.800
*Molybdenum	3.960	1.760
Tantalum	.354	---
Vanadium	.079	---
Tungsten	2.740	1.220
*Oil and Grease	7.870	7.870
*TSS	11.800	9.450
*pH	Within the range of 7.5 to 10.0 at all times	

Table XI-7

TITANIUM FORMING SUBCATEGORY
NEW SOURCE PERFORMANCE STANDARDS

NSPS
Titanium Forming
Rolling Spent Neat Oils

There shall be no discharge of process wastewater pollutants.

NSPS
Titanium Forming
Rolling Contact Cooling Water

Pollutant or pollutant property	Maximum for any one day	Maximum for monthly average
mg/off-kg (lb/million off-lbs) of titanium rolled with contact cooling water		
Chromium	.215	.088
Copper	.927	.488
*Cyanide	.142	.059
*Lead	.205	.098
Nickel	.937	.620
*Zinc	.713	.298
*Ammonia	65.100	28.600
*Fluoride	29.100	12.900
Titanium	.459	.200
*Oil and Grease	9.760	5.860
*TSS	20.000	9.520
*pH	Within the range of 7.5 to 10.0 at all times	

NSPS
Titanium Forming
Drawing Spent Neat Oils

There shall be no discharge of process wastewater pollutants.

NSPS
Titanium Forming
Extrusion Spent Neat Oils

There shall be no discharge of process wastewater pollutants.

Table XI-7 (Continued)

TITANIUM FORMING SUBCATEGORY
NEW SOURCE PERFORMANCE STANDARDS

NSPS

Titanium Forming
Extrusion Spent Emulsions

Pollutant or pollutant property	Maximum for any one day	Maximum for monthly average
mg/off-kg (lb/million off-lbs) of titanium extruded with emulsions		
Chromium	.032	.013
Copper	.137	.072
*Cyanide	.021	.009
*Lead	.030	.014
Nickel	.138	.091
*Zinc	.105	.044
*Ammonia	9.590	4.220
*Fluoride	4.280	1.900
Titanium	.068	.030
*Oil and Grease	1.440	.863
*TSS	2.950	1.400
*pH	Within the range of 7.5 to 10.0 at all times	

Table XI-7 (Continued)

TITANIUM FORMING SUBCATEGORY
NEW SOURCE PERFORMANCE STANDARDS

NSPS
Titanium Forming
Extrusion Press Hydraulic Fluid Leakage

Pollutant or pollutant property	Maximum for any one day	Maximum for monthly average
mg/off-kg (lb/million off-lbs) of titanium extruded		
Chromium	.078	.032
Copper	.338	.178
*Cyanide	.052	.021
*Lead	.075	.036
Nickel	.342	.226
*Zinc	.260	.109
*Ammonia	23.700	10.500
*Fluoride	10.600	4.700
Titanium	.168	.073
*Oil and Grease	3.560	2.140
*TSS	7.300	3.470
*pH	Within the range of 7.5 to 10.0 at all times	

NSPS
Titanium Forming
Forging Spent Lubricants

There shall be no discharge of process wastewater
pollutants.

Table XI-7 (Continued)

TITANIUM FORMING SUBCATEGORY
NEW SOURCE PERFORMANCE STANDARDS

NSPS

Titanium Forming
Forging Contact Cooling Water

Pollutant or pollutant property	Maximum for any one day	Maximum for monthly average
mg/off-kg (lb/million off-lbs) of forged titanium cooled with water		
Chromium	.044	.018
Copper	.190	.100
*Cyanide	.029	.012
*Lead	.042	.020
Nickel	.192	.127
*Zinc	.146	.061
*Ammonia	13.300	5.860
*Fluoride	5.950	2.640
Titanium	.094	.041
*Oil and Grease	2.000	1.200
*TSS	4.100	1.950
*pH	Within the range of 7.5 to 10.0 at all times	

Table XI-7 (Continued)

TITANIUM FORMING SUBCATEGORY
NEW SOURCE PERFORMANCE STANDARDS

NSPS

Titanium Forming

Forging Equipment Cleaning Wastewater

Pollutant or pollutant property	Maximum for any one day	Maximum for monthly average
mg/off-kg (lb/million off-lbs) of titanium forged		
Chromium	.018	.007
Copper	.076	.040
*Cyanide	.012	.005
*Lead	.017	.008
Nickel	.077	.051
*Zinc	.058	.024
*Ammonia	5.330	2.350
*Fluoride	2.380	1.060
Titanium	.038	.016
*Oil and Grease	.800	.480
*TSS	1.640	.780
*pH	Within the range of 7.5 to 10.0 at all times	

Table XI-7 (Continued)

TITANIUM FORMING SUBCATEGORY
NEW SOURCE PERFORMANCE STANDARDS

NSPS
Titanium Forming
Forging Press Hydraulic Fluid Leakage

Pollutant or pollutant property	Maximum for any one day	Maximum for monthly average
mg/off-kg (lb/million off-lbs) of titanium forged		
Chromium	.445	.182
Copper	1.920	1.010
*Cyanide	.293	.121
*Lead	.424	.202
Nickel	1.940	1.280
*Zinc	1.480	.616
*Ammonia	135.000	59.200
*Fluoride	60.100	26.700
Titanium	.950	.414
*Oil and Grease	20.200	12.100
*TSS	41.400	19.700
*pH	Within the range of 7.5 to 10.0 at all times	

NSPS
Titanium Forming
Tube Reducing Spent Lubricants

There shall be no discharge of process wastewater pollutants.

NSPS
Titanium Forming
Heat Treatment Contact Cooling Water

There shall be no allowance for the discharge of process wastewater pollutants.

Table XI-7 (Continued)

TITANIUM FORMING SUBCATEGORY
NEW SOURCE PERFORMANCE STANDARDS

NSPS
Titanium Forming
Surface Treatment Spent Baths

Pollutant or pollutant property	Maximum for any one day	Maximum for monthly average
mg/off-kg (lb/million off-lbs) of titanium surface treated		
Chromium	.092	.038
Copper	.395	.208
*Cyanide	.060	.025
*Lead	.087	.042
Nickel	.400	.264
*Zinc	.304	.127
*Ammonia	27.700	12.200
*Fluoride	12.400	5.490
Titanium	.196	.085
*Oil and Grease	4.160	2.500
*TSS	8.530	4.060
*pH	Within the range of 7.5 to 10.0 at all times	

NSPS
Titanium Forming
Surface Treatment Rinse

Pollutant or pollutant property	Maximum for any one day	Maximum for monthly average
mg/off-kg (lb/million off-lbs) of titanium surface treated		
Chromium	1.290	.526
Copper	5.550	2.920
*Cyanide	.847	.351
*Lead	1.230	.584
Nickel	5.610	3.710
*Zinc	4.270	1.780
*Ammonia	389.000	171.000
*Fluoride	174.000	77.100
Titanium	2.750	1.200
*Oil and Grease	58.400	35.100
*TSS	120.000	57.000
*pH	Within the range of 7.5 to 10.0 at all times	

Table XI-7 (Continued)

TITANIUM FORMING SUBCATEGORY
NEW SOURCE PERFORMANCE STANDARDS

NSPS
Titanium Forming
Alkaline Cleaning Spent Baths

Pollutant or pollutant property	Maximum for any one day	Maximum for monthly average
mg/off-kg (lb/million off-lbs) of titanium alkaline cleaned		
Chromium	.106	.043
Copper	.456	.240
*Cyanide	.070	.029
*Lead	.101	.048
Nickel	.461	.305
*Zinc	.351	.147
*Ammonia	32.000	14.100
*Fluoride	14.300	6.340
Titanium	.226	.098
*Oil and Grease	4.800	2.880
*TSS	9.840	4.680
*pH	Within the range of 7.5 to 10.0 at all times	

NSPS
Titanium Forming
Alkaline Cleaning Rinse

Pollutant or pollutant property	Maximum for any one day	Maximum for monthly average
mg/off-kg (lb/million off-lbs) of titanium alkaline cleaned		
Chromium	.122	.050
Copper	.525	.276
*Cyanide	.080	.033
*Lead	.116	.055
Nickel	.530	.351
*Zinc	.403	.169
*Ammonia	36.800	16.200
*Fluoride	16.400	7.290
Titanium	.260	.113
*Oil and Grease	5.520	3.310
*TSS	11.300	5.380
*pH	Within the range of 7.5 to 10.0 at all times	

Table XI-7 (Continued)

TITANIUM FORMING SUBCATEGORY
NEW SOURCE PERFORMANCE STANDARDS

NSPS
Titanium Forming
Molten Salt Rinse

Pollutant or pollutant property	Maximum for any one day	Maximum for monthly average
mg/off-kg (lb/million off-lbs) of titanium treated with molten salt		
Chromium	.420	.172
Copper	1.820	.955
*Cyanide	.277	.115
*Lead	.401	.191
Nickel	1.840	1.210
*Zinc	1.400	.583
*Ammonia	128.000	56.000
*Fluoride	56.800	25.200
Titanium	.898	.392
*Oil and Grease	19.100	11.500
*TSS	39.200	18.600
*pH	Within the range of 7.5 to 10.0 at all times	

NSPS
Titanium Forming
Tumbling Wastewater

Pollutant or pollutant property	Maximum for any one day	Maximum for monthly average
mg/off-kg (lb/million off-lbs) of titanium tumbled		
Chromium	.035	.014
Copper	.150	.079
*Cyanide	.023	.009
*Lead	.033	.016
Nickel	.152	.101
*Zinc	.116	.048
*Ammonia	10.600	4.630
*Fluoride	4.700	2.090
Titanium	.074	.032
*Oil and Grease	1.580	.948
*TSS	3.240	1.540
*pH	Within the range of 7.5 to 10.0 at all times	

Table XI-7 (Continued)

TITANIUM FORMING SUBCATEGORY
NEW SOURCE PERFORMANCE STANDARDS

NSPS
Titanium Forming
Sawing or Grinding Spent Neat Oils

There shall be no discharge of process wastewater pollutants.

NSPS
Titanium Forming
Sawing or Grinding Spent Emulsions

Pollutant or pollutant property	Maximum for any one day	Maximum for monthly average
mg/off-kg (lb/million off-lbs) of titanium sawed or ground with emulsions		
Chromium	.081	.033
Copper	.348	.183
*Cyanide	.053	.022
*Lead	.077	.037
Nickel	.352	.233
*Zinc	.267	.112
*Ammonia	24.400	10.700
*Fluoride	10.900	4.830
Titanium	.172	.075
*Oil and Grease	3.660	2.200
*TSS	7.510	3.570
*pH	Within the range of 7.5 to 10.0 at all times	

Table XI-7 (Continued)

TITANIUM FORMING SUBCATEGORY
NEW SOURCE PERFORMANCE STANDARDS

NSPS
Titanium Forming
Sawing or Grinding Contact Cooling Water

Pollutant or pollutant property	Maximum for any one day	Maximum for monthly average
mg/off-kg (lb/million off-lbs) of titanium sawed or ground with contact cooling water		
Chromium	.210	.086
Copper	.905	.476
*Cyanide	.138	.057
*Lead	.200	.095
Nickel	.914	.605
*Zinc	.695	.291
*Ammonia	63.500	27.900
*Fluoride	28.300	12.600
Titanium	.448	.195
*Oil and Grease	9.520	5.710
*TSS	19.500	9.280
*pH	Within the range of 7.5 to 10.0 at all times	

NSPS
Titanium Forming
Dye Penetrant Testing Wastewater

Pollutant or pollutant property	Maximum for any one day	Maximum for monthly average
mg/off-kg (lb/million off-lbs) of titanium tested with dye penetrant methods		
Chromium	.493	.202
Copper	2.130	1.120
*Cyanide	.325	.135
*Lead	.471	.224
Nickel	2.150	1.420
*Zinc	1.640	.683
*Ammonia	149.000	65.700
*Fluoride	66.700	29.600
Titanium	1.050	.459
*Oil and Grease	22.400	13.500
*TSS	45.900	21.900
*pH	Within the range of 7.5 to 10.0 at all times	

Table XI-7 (Continued)

TITANIUM FORMING SUBCATEGORY
NEW SOURCE PERFORMANCE STANDARDS

NSPS
Titanium Forming
Miscellaneous Wastewater Sources

Pollutant or pollutant property	Maximum for any one day	Maximum for monthly average
mg/off-kg (lb/million off-lbs) of titanium formed		
Chromium	.014	.006
Copper	.062	.032
*Cyanide	.009	.004
*Lead	.014	.006
Nickel	.062	.041
*Zinc	.047	.020
*Ammonia	4.320	1.900
*Fluoride	1.930	.856
Titanium	.031	.013
*Oil and Grease	.648	.389
*TSS	1.330	.632
*pH	Within the range of 7.5 to 10.0 at all times	

NSPS
Titanium Forming
Degreasing Spent Solvents

There shall be no discharge of process wastewater
pollutants.

Table XI-7 (Continued)

TITANIUM FORMING SUBCATEGORY
NEW SOURCE PERFORMANCE STANDARDS

NSPS
Titanium Forming
Wet Air Pollution Control Blowdown

Pollutant or pollutant property	Maximum for any one day	Maximum for monthly average
mg/off-kg (lb/million off-lbs) of titanium formed		
Chromium	.094	.039
Copper	.407	.214
*Cyanide	.062	.026
*Lead	.090	.043
Nickel	.411	.272
*Zinc	.313	.131
*Ammonia	28.500	12.600
*Fluoride	12.800	5.650
Titanium	.201	.088
*Oil and Grease	4.280	2.570
*TSS	8.780	4.180
*pH	Within the range of 7.5 to 10.0 at all times	

Table XI-8

URANIUM FORMING SUBCATEGORY
NEW SOURCE PERFORMANCE STANDARDS

NSPS
Uranium Forming
Extrusion Spent Lubricants

There shall be no discharge of process wastewater pollutants.

NSPS
Uranium Forming
Extrusion Tool Contact Cooling Water

Pollutant or pollutant property	Maximum for any one day	Maximum for monthly average
mg/off-kg (lb/million off-lbs) of uranium extruded		
*Cadmium	.007	.003
*Chromium	.013	.005
*Copper	.044	.021
*Lead	.010	.004
*Nickel	.019	.013
Zinc	.035	.015
*Fluoride	2.050	.908
*Molybdenum	.173	.077
Uranium	.148	.108
*Oil and Grease	.344	.344
*TSS	.516	.413
*pH	Within the range of 7.5 to 10.0 at all times	

NSPS
Uranium Forming
Forging Spent Lubricants

There shall be no discharge of process wastewater pollutants.

Table XI-8 (Continued)

URANIUM FORMING SUBCATEGORY
NEW SOURCE PERFORMANCE STANDARDS

NSPS
Uranium Forming
Heat Treatment Contact Cooling Water

Pollutant or pollutant property	Maximum for any one day	Maximum for monthly average
mg/off-kg (lb/million off-lbs) of extruded or forged uranium heat treated		
*Cadmium	.006	.003
*Chromium	.012	.005
*Copper	.040	.019
*Lead	.009	.004
*Nickel	.017	.012
Zinc	.032	.013
*Fluoride	1.860	.827
*Molybdenum	.158	.070
Uranium	.134	.098
*Oil and Grease	.313	.313
*TSS	.470	.376
*pH	Within the range of 7.5 to 10.0 at all times	

NSPS
Uranium Forming
Surface Treatment Spent Baths

Pollutant or pollutant property	Maximum for any one day	Maximum for monthly average
mg/off-kg (lb/million off-lbs) of uranium surface treated		
*Cadmium	.005	.002
*Chromium	.010	.004
*Copper	.035	.017
*Lead	.008	.004
*Nickel	.015	.010
Zinc	.028	.011
*Fluoride	1.620	.718
*Molybdenum	.137	.061
Uranium	.117	.085
*Oil and Grease	.272	.272
*TSS	.408	.327
*pH	Within the range of 7.5 to 10.0 at all times	

Table XI-8 (Continued)

URANIUM FORMING SUBCATEGORY
NEW SOURCE PERFORMANCE STANDARDS

NSPS
Uranium Forming
Surface Treatment Rinse

Pollutant or pollutant property	Maximum for any one day	Maximum for monthly average
mg/off-kg (lb/million off-lbs) of uranium surface treated		
*Cadmium	.067	.027
*Chromium	.125	.051
*Copper	.432	.206
*Lead	.094	.044
*Nickel	.186	.125
Zinc	.344	.142
*Fluoride	20.100	8.900
*Molybdenum	1.700	.752
Uranium	1.450	1.050
*Oil and Grease	3.370	3.370
*TSS	5.060	4.050
*pH	Within the range of 7.5 to 10.0 at all times	

NSPS
Uranium Forming
Sawing or Grinding Spent Emulsions

Pollutant or pollutant property	Maximum for any one day	Maximum for monthly average
mg/off-kg (lb/million off-lbs) of uranium sawed or ground with emulsions		
*Cadmium	.0011	.0005
*Chromium	.0021	.0009
*Copper	.0073	.0035
*Lead	.0016	.0007
*Nickel	.0031	.0021
Zinc	.0058	.0024
*Fluoride	.3380	.1500
*Molybdenum	.0286	.0127
Uranium	.0244	.0178
*Oil and Grease	.0568	.0568
*TSS	.0852	.0682
*pH	Within the range of 7.5 to 10.0 at all times	

Table XI-8 (Continued)

URANIUM FORMING SUBCATEGORY
NEW SOURCE PERFORMANCE STANDARDS

NSPS

Uranium Forming

Sawing or Grinding Contact Cooling Water

Pollutant or pollutant property	Maximum for any one day	Maximum for monthly average
mg/off-kg (lb/million off-lbs) of uranium sawed or ground with contact cooling water		
*Cadmium	.033	.013
*Chromium	.061	.025
*Copper	.211	.101
*Lead	.046	.022
*Nickel	.091	.061
Zinc	.169	.069
*Fluoride	9.820	4.360
*Molybdenum	.830	.368
Uranium	.708	.515
*Oil and Grease	1.650	1.650
*TSS	2.480	1.980
*pH	Within the range of 7.5 to 10.0 at all times	

NSPS

Uranium Forming

Sawing or Grinding Rinse

Pollutant or pollutant property	Maximum for any one day	Maximum for monthly average
mg/off-kg (lb/million off-lbs) of sawed or ground uranium rinsed		
*Cadmium	.0009	.0004
*Chromium	.0017	.0007
*Copper	.0060	.0028
*Lead	.0013	.0006
*Nickel	.0026	.0017
Zinc	.0048	.0020
*Fluoride	.2770	.1230
*Molybdenum	.0234	.0104
Uranium	.0200	.0145
*Oil and Grease	.0465	.0465
*TSS	.0698	.0558
*pH	Within the range of 7.5 to 10.0 at all times	

Table XI-8 (Continued)

URANIUM FORMING SUBCATEGORY
NEW SOURCE PERFORMANCE STANDARDS

NSPS
Uranium Forming
Area Cleaning Washwater

Pollutant or pollutant property	Maximum for any one day	Maximum for monthly average
mg/off-kg (lb/million off-lbs) of uranium formed		
*Cadmium	.009	.003
*Chromium	.016	.006
*Copper	.055	.026
*Lead	.012	.006
*Nickel	.024	.016
Zinc	.044	.018
*Fluoride	2.550	1.130
*Molybdenum	.216	.096
Uranium	.184	.134
*Oil and Grease	.429	.429
*TSS	.644	.515
*pH	Within the range of 7.5 to 10.0 at all times	

NSPS
Uranium Forming
Degreasing Spent Solvents

There shall be no discharge of process wastewater
pollutants.

Table XI-8 (Continued)

URANIUM FORMING SUBCATEGORY
NEW SOURCE PERFORMANCE STANDARDS

NSPS
Uranium Forming
Wet Air Pollution Control Blowdown

Pollutant or pollutant property	Maximum for any one day	Maximum for monthly average
mg/off-kg (lb/million off-lbs) of uranium surface treated		
*Cadmium	.0007	.0003
*Chromium	.0013	.0005
*Copper	.0045	.0021
*Lead	.0010	.0005
*Nickel	.0019	.0013
Zinc	.0036	.0015
*Fluoride	.2080	.0922
*Molybdenum	.0176	.0078
Uranium	.0150	.0109
*Oil and Grease	.0349	.0349
*TSS	.0524	.0419
*pH	Within the range of 7.5 to 10.0 at all times	

NSPS
Uranium Forming
Drum Washwater

Pollutant or pollutant property	Maximum for any one day	Maximum for monthly average
mg/off-kg (lb/million off-lbs) of uranium formed		
*Cadmium	.009	.004
*Chromium	.016	.007
*Copper	.057	.027
*Lead	.012	.006
*Nickel	.024	.016
Zinc	.045	.019
*Fluoride	2.640	1.170
*Molybdenum	.223	.099
Uranium	.190	.138
*Oil and Grease	.443	.443
*TSS	.665	.532
*pH	Within the range of 7.5 to 10.0 at all times	

Table XI-8 (Continued)

URANIUM FORMING SUBCATEGORY
NEW SOURCE PERFORMANCE STANDARDS

NSPS
Uranium Forming
Laundry
Washwater

Pollutant or pollutant property	Maximum for any one day	Maximum for monthly average
mg/employee-day uranium formed		
Cadmium	5.240	2.100
Chromium	9.700	3.930
Copper	33.600	16.000
Lead	7.340	3.410
Nickel	14.400	9.700
Zinc	26.700	11.000
Fluoride	1,560.000	692.000
Molybdenum	132.000	58.400
Uranium	113.000	81.800
Oil and Grease	262.000	262.000
TSS	393.000	315.000
*pH	Within the range of 7.5 to 10.0 at all times	

Table XI-9

ZINC FORMING SUBCATEGORY
NEW SOURCE PERFORMANCE STANDARDS

NSPS
Zinc Forming
Rolling Spent Neat Oils

There shall be no discharge of process wastewater pollutants.

NSPS
Zinc Forming
Rolling Spent Emulsions

Pollutant or pollutant property	Maximum for any one day	Maximum for monthly average
mg/off-kg (lb/million off-lbs) of zinc rolled with emulsions		
*Chromium	.0005	.0002
*Copper	.0018	.0009
*Cyanide	.0003	.0001
Nickel	.0008	.0005
*Zinc	.0014	.0006
*Oil and Grease	.0139	.0139
*TSS	.0209	.0167
*pH	Within the range of 7.5 to 10.0 at all times	

NSPS
Zinc Forming
Rolling Contact Cooling Water

Pollutant or pollutant property	Maximum for any one day	Maximum for monthly average
mg/off-kg (lb/million off-lbs) of zinc rolled with contact cooling water		
*Chromium	.020	.008
*Copper	.069	.033
*Cyanide	.011	.004
Nickel	.030	.020
*Zinc	.055	.023
*Oil and Grease	.536	.536
*TSS	.804	.643
*pH	Within the range of 7.5 to 10.0 at all times	

Table XI-9 (Continued)

ZINC FORMING SUBCATEGORY
NEW SOURCE PERFORMANCE STANDARDS

NSPS
Zinc Forming
Drawing Spent Emulsions

Pollutant or pollutant property	Maximum for any one day	Maximum for monthly average
mg/off-kg (lb/million off-lbs) of zinc drawn with emulsions		
*Chromium	.0022	.0009
*Copper	.0074	.0035
*Cyanide	.0012	.0005
Nickel	.0032	.0022
*Zinc	.0059	.0024
*Oil and Grease	.0580	.0580
*TSS	.0870	.0696
*pH	Within the range of 7.5 to 10.0 at all times	

NSPS
Zinc Forming
Direct Chill Casting Contact Cooling Water

Pollutant or pollutant property	Maximum for any one day	Maximum for monthly average
mg/off-kg (lb/million off-lbs) of zinc cast by the direct chill method		
*Chromium	.019	.008
*Copper	.065	.031
*Cyanide	.010	.004
Nickel	.028	.019
*Zinc	.052	.021
*Oil and Grease	.505	.505
*TSS	.758	.606
*pH	Within the range of 7.5 to 10.0 at all times	

Table XI-9 (Continued)

ZINC FORMING SUBCATEGORY
NEW SOURCE PERFORMANCE STANDARDS

NSPS
Zinc Forming
Stationary Casting Contact Cooling Water

There shall be no discharge of process wastewater pollutants.

NSPS
Zinc Forming
Heat Treatment Contact Cooling Water

Pollutant or pollutant property	Maximum for any one day	Maximum for monthly average
<hr/>		
mg/off-kg (lb/million off-lbs) of zinc heat treated		
*Chromium	.028	.012
*Copper	.098	.047
*Cyanide	.015	.006
Nickel	.042	.028
*Zinc	.078	.032
*Oil and Grease	.763	.763
*TSS	1.150	.916
*pH	Within the range of 7.5 to 10.0 at all times	

NSPS
Zinc Forming
Surface Treatment Spent Baths

Pollutant or pollutant property	Maximum for any one day	Maximum for monthly average
<hr/>		
mg/off-kg (lb/million off-lbs) of zinc surface treated		
*Chromium	.033	.013
*Copper	.114	.054
*Cyanide	.018	.007
Nickel	.049	.033
*Zinc	.091	.037
*Oil and Grease	.887	.887
*TSS	1.330	1.070
*pH	Within the range of 7.5 to 10.0 at all times	

Table XI-9 (Continued)

ZINC FORMING SUBCATEGORY
NEW SOURCE PERFORMANCE STANDARDS

NSPS
Zinc Forming
Surface Treatment Rinse

Pollutant or pollutant property	Maximum for any one day	Maximum for monthly average
mg/off-kg (lb/million off-lbs) of zinc surface treated		
*Chromium	.133	.054
*Copper	.458	.219
*Cyanide	.072	.029
Nickel	.197	.133
*Zinc	.365	.151
*Oil and Grease	3.580	3.580
*TSS	5.370	4.300
*pH	Within the range of 7.5 to 10.0 at all times	

NSPS
Zinc Forming
Alkaline Cleaning Spent Baths

Pollutant or pollutant property	Maximum for any one day	Maximum for monthly average
mg/off-kg (lb/million off-lbs) of zinc alkaline cleaned		
*Chromium	.0013	.0005
*Copper	.0046	.0022
*Cyanide	.0007	.0003
Nickel	.0020	.0013
*Zinc	.0036	.0015
*Oil and Grease	.0355	.0355
*TSS	.0533	.0426
*pH	Within the range of 7.5 to 10.0 at all times	

Table XI-9 (Continued)

ZINC FORMING SUBCATEGORY
NEW SOURCE PERFORMANCE STANDARDS

NSPS
Zinc Forming
Alkaline Cleaning Rinse

Pollutant or pollutant property	Maximum for any one day	Maximum for monthly average
mg/off-kg (lb/million off-lbs) of zinc alkaline cleaned		
*Chromium	.626	.254
*Copper	2.170	1.030
*Cyanide	.338	.135
Nickel	.930	.626
*Zinc	1.730	.710
*Oil and Grease	16.900	16.900
*TSS	25.400	20.300
*pH	Within the range of 7.5 to 10.0 at all times	

NSPS
Zinc Forming
Sawing or Grinding Spent Emulsions

Pollutant or pollutant property	Maximum for any one day	Maximum for monthly average
mg/off-kg (lb/million off-lbs) of zinc sawed or ground with emulsions		
*Chromium	.009	.004
*Copper	.031	.015
*Cyanide	.005	.002
Nickel	.013	.009
*Zinc	.024	.010
*Oil and Grease	.238	.238
*TSS	.357	.286
*pH	Within the range of 7.5 to 10.0 at all times	

Table XI-9 (Continued)

ZINC FORMING SUBCATEGORY
NEW SOURCE PERFORMANCE STANDARDS

NSPS
Zinc Forming
Degreasing Spent Solvents

There shall be no discharge of process wastewater pollutants.

NSPS
Zinc Forming
Electrocoating Rinse

Pollutant or pollutant property	Maximum for any one day	Maximum for monthly average
mg/off-kg (lb/million off-lbs) of zinc electrocoated		
*Chromium	.085	.034
*Copper	.293	.140
*Cyanide	.046	.018
Nickel	.126	.085
*Zinc	.234	.096
*Oil and Grease	2.290	2.290
*TSS	3.440	2.750
*pH	Within the range of 7.5 to 10.0 at all times	

Table XI-10

ZIRCONIUM-HAFNIUM FORMING SUBCATEGORY
NEW SOURCE PERFORMANCE STANDARDS

NSPS

Zirconium-Hafnium Forming
Rolling Spent Neat Oils

There shall be no discharge of process wastewater pollutants.

NSPS

Zirconium-Hafnium Forming
Drawing Spent Lubricants

There shall be no discharge of process wastewater pollutants.

NSPS

Zirconium-Hafnium Forming
Extrusion Spent Lubricants

There shall be no discharge of process wastewater pollutants.

NSPS

Zirconium-Hafnium Forming
Extrusion Press Hydraulic Fluid Leakage

Pollutant or pollutant property	Maximum for any one day	Maximum for monthly average
mg/off-kg (lb/million off-lbs) of zirconium-hafnium extruded		
*Chromium	.104	.043
Copper	.451	.237
*Cyanide	.069	.029
Lead	.100	.047
*Nickel	.455	.301
Zinc	.346	.145
*Ammonia	31.600	13.900
*Fluoride	14.100	6.260
Zirconium	6.830	3.300
*Oil and Grease	4.740	2.850
*TSS	9.720	4.620
*pH	Within the range of 7.5 to 10.0 at all times	

Table XI-10 (Continued)

ZIRCONIUM-HAFNIUM FORMING SUBCATEGORY
NEW SOURCE PERFORMANCE STANDARDS

NSPS
Zirconium-Hafnium Forming
Swaging Spent Neat Oils

There shall be no discharge of process wastewater pollutants.

NSPS
Zirconium-Hafnium Forming
Tube Reducing Spent Lubricants

There shall be no discharge of process wastewater pollutants.

NSPS
Zirconium-Hafnium Forming
Heat Treatment Contact Cooling Water

Pollutant or pollutant property	Maximum for any one day	Maximum for monthly average
mg/off-kg (lb/million off-lbs) of zirconium-hafnium heat treated		
*Chromium	.015	.006
Copper	.065	.034
*Cyanide	.010	.004
Lead	.014	.007
*Nickel	.066	.044
Zinc	.050	.021
*Ammonia	4.570	2.010
*Fluoride	2.040	.906
Zirconium	.988	.477
*Oil and Grease	.686	.412
*TSS	1.410	.669
*pH	Within the range of 7.5 to 10.0 at all times	

Table XI-10 (Continued)

ZIRCONIUM-HAFNIUM FORMING SUBCATEGORY
NEW SOURCE PERFORMANCE STANDARDS

NSPS

Zirconium-Hafnium Forming
Surface Treatment Spent Baths

Pollutant or pollutant property	Maximum for any one day	Maximum for monthly average
mg/off-kg (lb/million off-lbs) of zirconium-hafnium surface treated		
*Chromium	.150	.061
Copper	.646	.340
*Cyanide	.099	.041
Lead	.143	.068
*Nickel	.653	.432
Zinc	.497	.208
*Ammonia	45.300	19.900
*Fluoride	20.300	8.980
Zirconium	9.790	4.730
*Oil and Grease	6.800	4.080
*TSS	14.000	6.630
*pH	Within the range of 7.5 to 10.0 at all times	

NSPS

Zirconium-Hafnium Forming
Surface Treatment Rinse

Pollutant or pollutant property	Maximum for any one day	Maximum for monthly average
mg/off-kg (lb/million off-lbs) of zirconium-hafnium surface treated		
*Chromium	.391	.160
Copper	1.690	.888
*Cyanide	.258	.107
Lead	.373	.178
*Nickel	1.710	1.130
Zinc	1.300	.542
*Ammonia	119.000	52.100
*Fluoride	52.900	23.500
Zirconium	25.600	12.400
*Oil and Grease	17.800	10.700
*TSS	36.400	17.300
*pH	Within the range of 7.5 to 10.0 at all times	

Table XI-10 (Continued)

ZIRCONIUM-HAFNIUM SUBCATEGORY
NEW SOURCE PERFORMANCE STANDARDS

NSPS
Zirconium-Hafnium Forming
Alkaline Cleaning Spent Baths

Pollutant or pollutant property	Maximum for any one day	Maximum for monthly average
mg/off-kg (lb/million off-lbs) of zirconium-hafnium alkaline cleaned		
*Chromium	.704	.288
Copper	3.040	1.600
*Cyanide	.464	.192
Lead	.672	.320
*Nickel	3.070	2.030
Zinc	2.340	.976
*Ammonia	213.000	93.800
*Fluoride	95.200	42.300
Zirconium	46.100	22.300
*Oil and Grease	32.000	19.200
*TSS	65.600	31.200
*pH	Within the range of 7.5 to 10.0 at all times	

NSPS
Zirconium-Hafnium Forming
Alkaline Cleaning Rinse

Pollutant or pollutant property	Maximum for any one day	Maximum for monthly average
mg/off-kg (lb/million off-lbs) of zirconium-hafnium alkaline cleaned		
*Chromium	1.380	.565
Copper	5.970	3.140
*Cyanide	.911	.377
Lead	1.320	.628
*Nickel	6.030	3.990
Zinc	4.590	1.920
*Ammonia	419.000	184.000
*Fluoride	187.000	82.900
Zirconium	90.500	43.700
*Oil and Grease	62.800	37.700
*TSS	129.000	61.300
*pH	Within the range of 7.5 to 10.0 at all times	

Table XI-10 (Continued)

ZIRCONIUM-HAFNIUM FORMING SUBCATEGORY
NEW SOURCE PERFORMANCE STANDARDS

NSPS
Zirconium-Hafnium Forming
Molten Salt Rinse

Pollutant or pollutant property	Maximum for any one day	Maximum for monthly average
mg/off-kg (lb/million off-lbs) of zirconium-hafnium treated with molten salt		
*Chromium	.333	.136
Copper	1.440	.756
*Cyanide	.219	.091
Lead	.318	.151
*Nickel	1.450	.960
Zinc	1.110	.461
*Ammonia	101.000	44.300
*Fluoride	45.000	20.000
Zirconium	21.800	10.500
*Oil and Grease	15.100	9.070
*TSS	31.000	14.800
*pH	Within the range of 7.5 to 10.0 at all times	

NSPS
Zirconium-Hafnium Forming
Sawing or Grinding Spent Emulsions

Pollutant or pollutant property	Maximum for any one day	Maximum for monthly average
mg/off-kg (lb/million off-lbs) of zirconium-hafnium sawed or ground with emulsions		
*Chromium	.124	.051
Copper	.534	.281
*Cyanide	.082	.034
Lead	.118	.056
*Nickel	.540	.357
Zinc	.410	.172
*Ammonia	37.500	16.500
*Fluoride	16.700	7.420
Zirconium	8.090	3.910
*Oil and Grease	5.620	3.370
*TSS	11.500	5.480
*pH	Within the range of 7.5 to 10.0 at all times	

Table XI-10 (Continued)

ZIRCONIUM-HAFNIUM FORMING SUBCATEGORY
NEW SOURCE PERFORMANCE STANDARDS

NSPS

Zirconium-Hafnium Forming
Sawing or Grinding Contact Cooling Water

Pollutant or pollutant property	Maximum for any one day	Maximum for monthly average
mg/off-kg (lb/million off-lbs) of zirconium-hafnium sawed or ground with contact cooling water		
*Chromium	.141	.058
Copper	.610	.321
*Cyanide	.093	.039
Lead	.135	.064
*Nickel	.617	.408
Zinc	.469	.196
*Ammonia	42.800	18.800
*Fluoride	19.100	8.480
Zirconium	9.250	4.460
*Oil and Grease	6.420	3.850
*TSS	13.200	6.260
*pH	Within the range of 7.5 to 10.0 at all times	

NSPS

Zirconium-Hafnium Forming
Sawing or Grinding Rinse

Pollutant or pollutant property	Maximum for any one day	Maximum for monthly average
mg/off-kg (lb/million off-lbs) of sawed or ground zirconium-hafnium rinsed		
*Chromium	.079	.032
Copper	.342	.180
*Cyanide	.052	.022
Lead	.076	.036
*Nickel	.346	.229
Zinc	.263	.110
*Ammonia	24.000	10.600
*Fluoride	10.700	4.750
Zirconium	5.190	2.500
*Oil and Grease	3.600	2.160
*TSS	7.380	3.510
*pH	Within the range of 7.5 to 10.0 at all times	

Table XI-10 (Continued)

ZIRCONIUM-HAFNIUM FORMING SUBCATEGORY
NEW SOURCE PERFORMANCE STANDARDS

NSPS
Zirconium-Hafnium Forming
Inspection and Testing Wastewater

Pollutant or pollutant property	Maximum for any one day	Maximum for monthly average
mg/off-kg (lb/million off-lbs) of zirconium-hafnium tested		
*Chromium	.007	.003
Copper	.029	.015
*Cyanide	.004	.002
Lead	.006	.003
*Nickel	.030	.020
Zinc	.023	.009
*Ammonia	2.050	.903
*Fluoride	.917	.407
Zirconium	.444	.214
*Oil and Grease	.308	.185
*TSS	.632	.301
*pH	Within the range of 7.5 to 10.0 at all times	

NSPS
Zirconium-Hafnium Forming
Degreasing Spent Solvents

There shall be no discharge of process wastewater
pollutants.

NSPS
Zirconium-Hafnium Forming
Wet Air Pollution Control Blowdown

There shall be no allowance for the discharge of process
wastewater pollutants.

NSPS
Zirconium-Hafnium Forming
Degreasing Rinse

There shall be no discharge of process wastewater
pollutants.

Table XI-11

METAL POWDERS SUBCATEGORY
NEW SOURCE PERFORMANCE STANDARDS

NSPS
Metal Powders
Metal Powder Production Atomization Wastewater

Pollutant or pollutant property	Maximum for any one day	Maximum for monthly average
mg/off-kg (lb/million off-lbs) of powder wet atomized		
Chromium	2.220	.907
*Copper	9.580	5.040
*Cyanide	1.460	.605
*Lead	2.120	1.010
Nickel	9.680	6.400
Zinc	7.360	3.080
Aluminum	32.400	16.100
Iron	6.050	3.080
*Oil and Grease	101.000	60.500
*TSS	207.000	98.300
*pH	Within the range of 7.5 to 10.0 at all times	

NSPS
Metal Powders
Tumbling, Burnishing, or Cleaning Wastewater

Pollutant or pollutant property	Maximum for any one day	Maximum for monthly average
mg/off-kg (lb/million off-lbs) of powder metallurgy parts tumbled, burnished, or cleaned		
Chromium	.194	.079
*Copper	.836	.440
*Cyanide	.128	.053
*Lead	.185	.088
Nickel	.845	.559
Zinc	.643	.269
Aluminum	2.830	1.410
Iron	.528	.269
*Oil and Grease	8.800	5.280
*TSS	18.100	8.580
*pH	Within the range of 7.5 to 10.0 at all times	

Table XI-11 (Continued)

METAL POWDERS SUBCATEGORY
NEW SOURCE PERFORMANCE STANDARDS

NSPS
Metal Powders
Sawing or Grinding Spent Neat Oils

There shall be no discharge of process wastewater pollutants.

NSPS
Metal Powders
Sawing or Grinding Spent Emulsions

Pollutant or pollutant property	Maximum for any one day	Maximum for monthly average
mg/off-kg (lb/million off-lbs) of powder metallurgy parts sawed or ground with emulsions		
Chromium	.008	.003
*Copper	.034	.018
*Cyanide	.005	.002
*Lead	.008	.004
Nickel	.035	.023
Zinc	.026	.011
Aluminum	.117	.058
Iron	.022	.011
*Oil and Grease	.362	.217
*TSS	.742	.353
*pH	Within the range of 7.5 to 10.0 at all times	

Table XI-11 (Continued)

METAL POWDERS SUBCATEGORY
NEW SOURCE PERFORMANCE STANDARDS

NSPS
Metal Powders
Sawing or Grinding Contact Cooling Water

Pollutant or pollutant property	Maximum for any one day	Maximum for monthly average
mg/off-kg (lb/million off-lbs) of powder metallurgy parts sawed or ground with contact cooling water		
Chromium	.713	.292
*Copper	3.080	1.620
*Cyanide	.470	.195
*Lead	.681	.324
Nickel	3.110	2.060
Zinc	2.370	.988
Aluminum	10.400	5.190
Iron	1.950	.988
*Oil and Grease	32.400	19.500
*TSS	66.400	31.600
*pH	Within the range of 7.5 to 10.0 at all times	

NSPS
Metal Powders
Sizing Spent Neat Oils

There shall be no discharge of process wastewater pollutants.

Table XI-11 (Continued)

METAL POWDERS SUBCATEGORY
NEW SOURCE PERFORMANCE STANDARDS

NSPS
Metal Powders
Sizing Spent Emulsions

Pollutant or pollutant property	Maximum for any one day	Maximum for monthly average
mg/off-kg (lb/million off-lbs) of powder sized		
Chromium	.006	.003
*Copper	.028	.015
*Cyanide	.004	.002
*Lead	.006	.003
Nickel	.028	.019
Zinc	.021	.009
Aluminum	.094	.047
Iron	.018	.009
*Oil and Grease	.292	.175
*TSS	.599	.285
*pH	Within the range of 7.5 to 10.0 at all times	

NSPS
Metal Powders
Steam Treatment Wet Air Pollution Control Blowdown

Pollutant or pollutant property	Maximum for any one day	Maximum for monthly average
mg/off-kg (lb/million off-lbs) of powder metallurgy parts steam treated		
Chromium	.035	.014
*Copper	.151	.079
*Cyanide	.023	.010
*Lead	.033	.016
Nickel	.152	.101
Zinc	.116	.048
Aluminum	.509	.254
Iron	.095	.048
*Oil and Grease	1.590	.951
*TSS	3.250	1.550
*pH	Within the range of 7.5 to 10.0 at all times	

Table XI-11 (Continued)

METAL POWDERS SUBCATEGORY
NEW SOURCE PERFORMANCE STANDARDS

NSPS
Metal Powders
Oil-Resin Impregnation Spent Neat Oils

There shall be no discharge of process wastewater pollutants.

NSPS
Metal Powders
Degreasing Spent Solvents

There shall be no discharge of process wastewater pollutants.

NSPS
Metal Powders
Hot Pressing Contact Cooling Water

Pollutant or pollutant property	Maximum for any one day	Maximum for monthly average
mg/off-kg (lb/million off-lbs) of powder cooled after pressing		
Chromium	.387	.159
*Copper	1.670	.880
*Cyanide	.255	.106
*Lead	.370	.176
Nickel	1.690	1.120
Zinc	1.290	.537
Aluminum	5.660	2.820
Iron	1.060	.537
*Oil and Grease	17.600	10.600
*TSS	36.100	17.200
*pH	Within the range of 7.5 to 10.0 at all times	

Table XI-11 (Continued)

METAL POWDERS SUBCATEGORY
NEW SOURCE PERFORMANCE STANDARDS

NSPS
Metal Powders
Mixing Wet Air Pollution Control Blowdown

Pollutant or pollutant property	Maximum for any one day	Maximum for monthly average
mg/off-kg (lb/million off-lbs) of powder mixed		
Chromium	3.480	1.420
*Copper	15.000	7.900
*Cyanide	2.290	.948
*Lead	3.320	1.580
Nickel	15.200	10.100
Zinc	11.600	4.820
Aluminum	50.800	25.300
Iron	9.480	4.820
*Oil and Grease	158.000	94.800
*TSS	324.000	154.000
*pH	Within the range of 7.5 to 10.0 at all times	

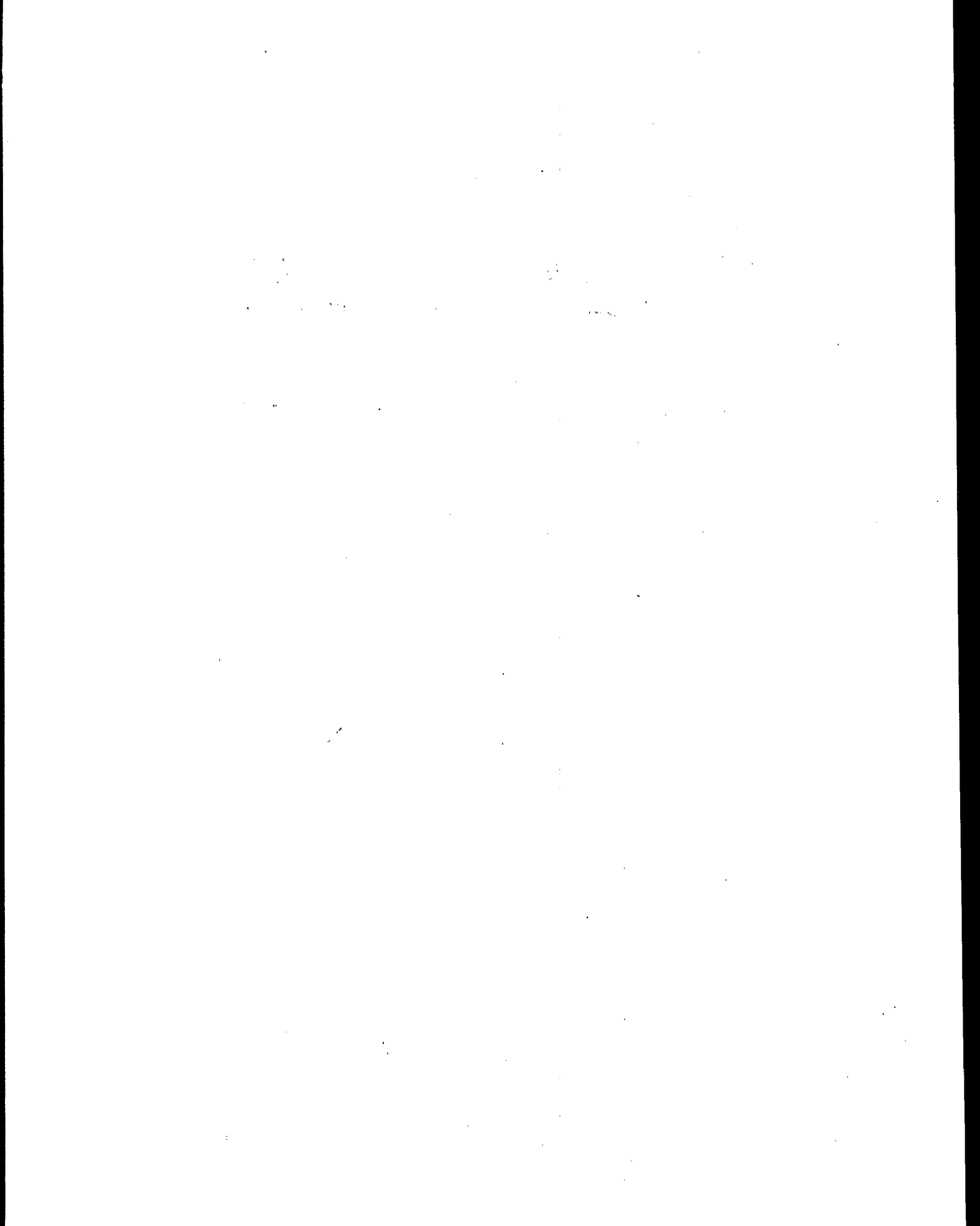

SECTION XII

PRETREATMENT STANDARDS

Section 307(b) of the Clean Water Act requires EPA to promulgate pretreatment standards for existing sources (PSES). These standards must be achieved within three years of promulgation. PSES are designed to prevent the discharges of pollutants which pass through, interfere with, or are otherwise incompatible with the operation of publicly owned treatment works (POTW). The Clean Water Act of 1977 adds a new dimension by requiring pretreatment for pollutants, such as heavy metals, that limit POTW sludge management alternatives, including the beneficial use of sludges on agricultural lands. The legislative history of the 1977 Act indicates that pretreatment standards are to be technology based, analogous to the best available technology for removal of priority pollutants.

Section 307(c) of the Act requires EPA to promulgate pretreatment standards for new sources (PSNS) at the same time that it promulgates NSPS. New indirect discharge facilities, like new direct discharge facilities, have the opportunity to incorporate the best available demonstrated technologies, including process changes, in-plant controls, and end-of-pipe treatment technologies, and to select a plant site that allows installation of an adequate treatment system.

General Pretreatment Regulations for Existing and New Sources of Pollutants were published in the Federal Register, Vol. 43, No. 123, Monday, June 26, 1978 and amended on January 28, 1981 (46 FR 9404). They appear in 40 CFR Part 403. These regulations describe the Agency's overall policy for establishing and enforcing pretreatment standards for new and existing users of a POTW and delineate the responsibilities and deadlines applicable to each party in this effort. 40 CFR 403.5(b) outlines prohibited discharges which apply to all users of a POTW.

This section describes the treatment and control technology for pretreatment of process wastewaters from existing sources and new sources, and presents mass discharge limitations of regulated pollutants for existing and new sources, based on the described control technology.

INTRODUCTION OF NONFERROUS METALS FORMING WASTEWATER INTO POTW

There are 121 plants in the nonferrous metals forming industry which discharge to a POTW. The plants that may be affected by pretreatment standards represent about 77 percent of the nonferrous metals forming plants which discharge wastewater and approximately 36 percent of the entire category.

Pretreatment standards are established to ensure removal of pollutants which interfere with, pass through, or are otherwise incompatible with a POTW. A determination of which pollutants

may pass through or be incompatible with POTW operations, and thus be subject to pretreatment standards, depends on the level of treatment employed by the POTW. In general, more pollutants will pass through or interfere with a POTW employing primary treatment (usually physical separation by settling) than one which has installed secondary treatment (settling plus biological treatment).

Many of the pollutants contained in nonferrous metals forming wastewaters are not biodegradable and are, therefore, ineffectively treated by biological treatment systems. Furthermore, these pollutants have been shown to pass through or interfere with the normal operations of these systems. Problems associated with the uncontrolled release of pollutant parameters identified in nonferrous metals forming process wastewater to POTW were discussed in Section VI. The discussion covered pass through, interference, and sludge useability.

The Agency based the selection of pretreatment standards for the nonferrous metals forming category on the minimization of pass through of priority pollutants at POTW. For each subcategory, the Agency compared removal rates for each priority pollutant limited by BAT to the national average removal rate for that pollutant at well-operated POTW achieving secondary treatment. The POTW removal rates were determined through a study conducted by the Agency at over 40 POTW and a statistical analysis of the data. (See Fate of Priority Pollutants in Publicly Owned Treatment Works, Final Report, EPA 440/1-82/303, September 1983; and Determining National Removal Credits for Selected Pollutants for Publicly Owned Treatment Works, EPA 440/2-82-008, September 1982.) The POTW removal rates of the major priority pollutants found in nonferrous metals forming wastewater are presented in Table XII-1.

The national average percentage of the priority metals removed by a well-operated POTW meeting secondary treatment requirements is about 50 percent (varying from 20 to 70 percent), whereas the percentage that can be removed by a nonferrous metals forming indirect discharger applying the best available technology economically achievable is about 90 percent. Accordingly, these pollutants pass through a POTW. Specific percent removals for the PSES technology are shown in Table XII-2. The pretreatment options selected provide for significantly more removal of priority pollutants than would occur if nonferrous metals forming wastewaters were discharged untreated to POTW. Thus, pretreatment standards will control the discharge of priority pollutants to POTW and prevent pass-through.

TECHNICAL APPROACH TO PRETREATMENT

The pretreatment options for existing sources and new sources are identical to the options considered for BAT and NSPS which are discussed in Sections X and XI of this document.

Treatment technologies and controls employed for the pretreatment

options are:

Pretreatment Option 1 is based on:

Oil skimming,
Lime and settle (chemical precipitation of metals followed
by sedimentation),
pH adjustment; and, where required,
Iron co-precipitation,
Chemical emulsion breaking,
Ammonia steam stripping,
Cyanide removal, and Hexavalent chromium reduction.

Pretreatment Option 2 is based on:

Pretreatment Option 1, plus process wastewater flow minimization by the following methods:

- Contact cooling water recycle through cooling towers or holding tanks.
- Air pollution control scrubber liquor recycle.
- Countercurrent cascade rinsing or other water efficient methods applied to surface treatment rinses and alkaline cleaning rinses.
- Use of periodic batch discharges or decreased flow rate for molten salt rinsewater.
- Recycle of equipment cleaning wastewater, tumbling, burnishing, and cleaning wastewater, and other wastewater streams through holding tanks with suspended solids removal, if necessary.

Pretreatment Option 3 is based on:

Pretreatment Option 2, plus multimedia filtration at the end of the Pretreatment Option 2 treatment train.

PSES AND PSNS OPTION SELECTION

The Agency is promulgating PSES for each of the nonferrous forming subcategories on the same technology basis as BAT except for the uranium, zinc, and refractory metals subcategories. The options selected as the technology basis for PSES and PSNS are summarized in Table XII-3. In the nonferrous metals forming category, the Agency has concluded that the regulated metal priority pollutants, ammonia, fluoride, and molybdenum pass through the POTW. A study of 40 well-operated POTW with biological treatment that are meeting secondary treatment criteria showed that regulated metals are typically removed at rates varying from 20 to 70 percent. POTW with only primary treatment have even lower rates of removal. In contrast, BAT level treatment by nonferrous metals forming industrial facilities can achieve removals of these pollutants of approximately 90 percent (see Table XII-2). Thus it is evident that metals from this category do pass through POTW. Many of the pollutants present in nonferrous metals forming waste streams, at sufficiently high

concentrations, can also inhibit biodegradation in POTW operations. In addition, a high concentration of toxic pollutants in the sludge can limit POTW use of sludge management alternatives, including the beneficial use of sludges on agricultural lands. Pass-through and concentration in POTW sludges are discussed in detail in Section VI for each priority pollutant (organics and metals) that was considered for regulation under pretreatment standards.

EPA is excluding the uranium forming subcategory from PSES because there are no existing indirect dischargers in the uranium forming subcategory. In addition, EPA is not promulgating any categorical PSES for zinc forming on the basis of available information, it appeared that the economic impact of pretreatment standards based on any available technology option would be disproportionate for this subcategory. However, these plants are still subject to the general pretreatment requirements.

PSES for the refractory metals subcategory is promulgated based on the model end-of-pipe treatment technology of lime and settle with in-process controls to reduce wastewater flows (Pretreatment Option 2). The Agency has decided not to include a filter in the model PSES technology for this subcategory because, based on the processes at existing refractory metal indirect dischargers, EPA estimates that 169,000 kg/yr (371,000 lb/yr) of pollutants, including 250 kg/yr (550 lb/yr) of toxic pollutants, will be removed after the installation of Option 2 technology at a cost of \$1.54 million in capital investment and \$0.7 million annually above equipment in place (1982 dollars). The addition of filtration would only remove an additional 9 kg/yr (20 lb/yr) of toxic pollutants (approximately 0.4 kg/yr (0.9 lb/yr) of toxic pollutants per plant), while the incremental cost of filters for refractory metal indirect dischargers is \$97,500 in capital investment and \$57,200 in annual costs (1982 dollars). These costs are significantly greater than the cost that will be incurred by existing direct dischargers.

Section 307(c) of the Act requires EPA to promulgate pretreatment standards for new sources (PSNS) at the same time that it promulgates NSPS. New indirect dischargers will produce wastes having the same pass through problems as described for existing dischargers. In selecting the technology basis for PSNS, the Agency compared the priority pollutant removals achieved by a well-operated POTW to that achieved by a direct discharger meeting NSPS. New indirect dischargers, like new direct dischargers, have the opportunity to incorporate the best available demonstrated technologies including process changes, in-plant controls, and end-of-pipe treatment technologies, and to select a plant site that allows installation of an adequate treatment system.

EPA is promulgating mass-based PSNS for all subcategories to assure that the identified flow reduction technologies are considered in new plant designs. In addition, EPA is issuing PSNS for the zinc forming and uranium forming subcategories for

which BAT and NSPS, but not PSES, are promulgated.

The technology basis for the promulgated PSNS is identical to NSPS. As discussed under PSES, pass through of the regulated pollutants will occur without adequate pretreatment and, therefore, pretreatment standards are required. The Agency did not identify any economically feasible, demonstrated technology that removes significantly more pollutants than this technology. The subcategories which have more stringent requirements for new sources than for existing sources are magnesium forming, refractory metals forming, and metal powders.

The Agency believes that compliance costs could be lower for new sources than the cost estimates for equivalent existing sources, because production processes can be designed on the basis of lower flows and there will be no costs associated with retrofitting the in-process controls. Therefore, new sources regardless, of whether they are plants with major modifications or greenfield sites, will have costs that are not greater than the costs that existing sources will incur in achieving equivalent pollutant discharge reduction. Based on this the Agency believes the PSNS do not pose a barrier to entry. Therefore, the selected PSNS is appropriate for both greenfield sites and existing sites undergoing major modifications (e.g., a primary zinc plant which installs a rolling operation).

Costs and Environmental Benefits of Treatment Options

As a means of evaluating the economic achievability of each of these options for PSES, the Agency developed estimates of the compliance costs and benefits. Estimates of capital and annual costs for the pretreatment options were prepared for each subcategory as an aid in choosing the best pretreatment option. The cost estimates for indirect dischargers are presented in Table XII-4.

The cost methodology has been described in detail in Section VIII. The benefit methodology has been described in detail in Section X. The pollutant reduction benefit estimates for eight subcategories are presented in Tables XII-5 through XII-12.

REGULATED POLLUTANT PARAMETERS

The same pollutants selected for regulation at BAT have been selected for regulation under the pretreatment standards for each of the eight subcategories regulated under PSES and each of the 10 subcategories regulated under PSNS. The selection process and pollutants selected for regulation are given in detail in Sections VI and X.

PRETREATMENT STANDARDS

PSES for this category are expressed in terms of mass per unit of production (mass-based) rather than concentration standards. Regulation on the basis of concentration is not appropriate for

this category because flow reduction is a significant part of the model technology for pretreatment. Therefore, the Agency is not proposing concentration-based pretreatment standards (40 CFR Part 403.6) for this category.

The regulatory production normalized flows for PSES are equivalent to BAT flows. The regulatory production normalized flows for PSNS are equivalent to the NSPS flows.

The selected PSES and PSNS options for each subcategory are based on the treatment effectiveness values presented in Table VII-21. The mass of pollutant allowed to be discharged per mass of product is calculated by multiplying the appropriate effectiveness value (one-day maximum and 10-day average values) (mg/l) by the production normalized flow (l/kg). The PSES values are presented for each of the eight subcategories for which PSES are promulgated in Tables XII-13 through XII-20. The PSNS values are presented for all 10 subcategories in Tables XII-21 through XII-30.

Section 307(b)(1) of the Clean Water Act requires that the date for compliance with PSES be no more than three years from the regulation's final promulgation date. Few of the 121 indirect dischargers in this category have installed and are properly operating the model treatment technologies that are the basis for PSES. The readjustment of internal processing conditions to achieve reduced wastewater flows may require further time above installation of end-of-pipe treatment equipment. Many plants in this and other industries also will be installing the treatment equipment suggested as model technologies for this regulation which may result in delays in engineering, ordering, installing, and operating this equipment. Under these circumstances, the Agency believes that three years is the appropriate compliance deadline under Section 307(b)(1) of the Clean Water Act.

Table XII-1

POTW REMOVALS OF THE TOXIC POLLUTANTS FOUND
IN NONFERROUS METALS FORMING WASTEWATER

Pollutant	Percent Removal by Secondary POTW
1. Acenaphthene	NA
2. Acrolein	NA
4. Benzene	78
5. Benzidene	NA
6. Carbon Tetrachloride	50
11. 1,1,1-Trichloroethane	87
13. 1,1-Dichloroethane	76
15. 1,1,2,2-Tetrachloroethane	NA
22. p-Chloro-m-Cresol	89
23. Chloroform	61
28. 3,3'-Dichlorobenzidene	NA
29. 1,1-Dichloroethylene	80
34. 2,4-Dimethylphenol	59
35. 2,4-Dinitrotoluene	NA
36. 2,6-Dinitrotoluene	NA
38. Ethylbenzene	84
39. Fluoranthene	NA
44. Methylene Chloride	58
45. Methyl Chloride	NA
51. Chlorodibromomethane	NA
55. Naphthalene	61
56. Nitrobenzene	NA
57. 2-Nitrophenol	NA
58. 4-Nitrophenol	NA
60. 4,6-Dinitro-o-cresol	NA
62. N-Nitrosodiphenylamine	NA
63. N-Nitrosodi-n-propylamine	NA
64. Pentachlorophenol	59
65. Phenol	96
66. Bis(2-Ethylhexyl) Phthalate	62
67. Butyl Benzyl Phthalate	59
68. Di-n-Butyl Phthalate	48
69. Di-n-Octyl Phthalate	81
70. Diethyl Phthalate	50
72. 1,2-Benzanthracene	NA
73. Benzo(a)pyrene	NA
74. 3,4-Benzofluoranthene	NA
76. Chrysene	NA
77. Acenaphthalene	NA
78. Anthracene	65
79. 1,12-Benzoperylene (Benzo(ghi)perylene)	83
80. Fluorene	NA
81. Phenanthrene	65
82. 1,2,5,6-Dibenzanthracene	NA

Table XII-1 (Continued)

POTW REMOVALS OF THE TOXIC POLLUTANTS FOUND
IN NONFERROUS METALS FORMING WASTEWATER

Pollutant	Percent Removal by Secondary POTW
83. Indeno(1,2,3-cd)pyrene	NA
84. Pyrene	40
85. Tetrachloroethylene	81
86. Toluene	90
87. Trichloroethylene	85
114. Antimony	60
115. Arsenic	65
117. Beryllium	NA
118. Cadmium	38
119. Chromium, hexavalent	18
Chromium, trivalent	NA
120. Copper	58
121. Cyanide	52
122. Lead	41
123. Mercury	48
124. Nickel	19
125. Selenium	46
126. Silver	66
127. Thallium	NA
128. Zinc	65

NA = Not Available.

NOTE: This data compiled from Fate of Priority Pollutants in Publicly Owned Treatment Works, USEPA, EPA No. 440/1-80-301, October 1980.

Table XII-2

POLLUTANT REMOVAL PERCENTAGES FOR BAT OR PSES MODEL TECHNOLOGY BY SUBCATEGORY

Pollutant	POTW	Lead-Tin-Bismuth	Magnesium	Nickel-Cobalt	Precious Metals	Refractory Metals	Titanium	Uranium	Zinc	Zirconium-Hafnium	Metal Powders
Aluminum	NA	--	--	--	--	--	--	--	--	--	47.5
Ammonia	NA	--	(A)	--	--	--	(A)	--	--	(A)	--
Antimony	NA	57.5	--	--	--	--	--	--	--	--	--
Cadmium	38	--	--	98.5	96.9	--	--	83.6	--	--	--
Chromium	65	--	100.0	99.8	--	91.9	86.1	94.7	0	87.5	0
Columbium	NA	--	--	--	--	99.7	--	--	--	--	--
Copper	58	--	--	97.7	93.1	38.1	0	78.7	--	0	93.4
Cyanide	52	--	--	--	(A)	--	(A)	--	(A)	(A)	(A)
Fluoride	NA	--	34.8	97.4	00	95.3	99.5	--	--	88.8	--
Hafnium	NA	--	--	--	--	--	--	--	--	(B)	--
Gold	NA	--	--	--	(B)	--	--	--	--	--	--
Iron	NA	--	--	--	--	--	--	--	--	--	97.8
Lead	48	99.7	--	88.8	39.1	0	97.6	99.6	--	(C)	93.2
Magnesium	NA	--	100.0	--	--	--	--	--	--	--	--
Molybdenum	NA	--	--	--	--	99.9	--	--	--	--	--
Nickel	19	--	--	99.9	0	95.5	9	57.7	93.9	(A)	0
Silver	66	--	--	--	72.9	(C)	--	--	--	--	--
Tantalum	NA	--	--	--	--	99.6	--	--	--	--	--
Titanium	NA	--	--	--	--	--	100.0	--	--	--	--
Tungsten	NA	--	--	--	--	100.0	--	--	--	--	--
Uranium	NA	--	--	--	--	--	--	99.9	--	--	--
Vanadium	NA	--	--	--	--	(B)	--	--	--	--	--
Zinc	65	--	98.9	87.5	87.4	9.0	92.1	--	99.0	94.2	53.9
Zirconium	NA	--	--	--	--	--	--	--	--	98.4	--

(A) Removal occurs at specific plants where treatment is applied if necessary, but not across the entire subcategory.

(B) Insufficient data available to calculate raw waste value.

(C) Raw waste value for indirect dischargers is zero.

Note: Uranium and zinc forming subcategory removal percentages are for BAT technology.
Refractory metals forming subcategory removal percentages are for PSES technology.

Table XII-3

OPTIONS SELECTED AS THE MODEL TECHNOLOGY BASES FOR PSES AND PSNS

Subcategory	PSES	PSNS
Lead-Tin-Bismuth Forming	Option 2	Option 2
Magnesium Forming	Option 2	Option 3
Nickel-Cobalt Forming	Option 3	Option 3
Precious Metals Forming	Option 2	Option 2
Refractory Metals Forming	Option 2	Option 3
Titanium Forming	Option 2	Option 2
Uranium Forming	Exempted	Option 3
Zinc Forming	Exempted	Option 3
Zirconium-Hafnium Forming	Option 2	Option 2
Metal Powders	Option 1	Option 2

Option 1 - Flow Normalization, Lime and Settle

Option 2 - Flow Reduction, Lime and Settle

Option 3 - Flow Reduction, Lime and Settle, Multimedia Filtration

Table XII-4

CAPITAL AND ANNUAL COST ESTIMATES FOR PSES OPTIONS
INDIRECT DISCHARGERS (\$1982)

Subcategory	Option 1	Option 2*	Option 3**
Lead-Tin-Bismuth Forming			
Capital	202,700	230,100	254,700
Annual	76,700	88,000	106,800
Magnesium Forming			
Capital	C	C	C
Annual	C	C	C
Nickel-Cobalt Forming			
Capital	2,868,800	3,238,700	3,529,500
Annual	1,857,200	1,952,000	2,104,300
Precious Metals Forming			
Capital	786,600	749,000	823,700
Annual	315,900	323,700	372,900
Refractory Metals Forming			
Capital	1,030,200	1,436,900	1,535,500
Annual	537,400	589,100	697,200
Titanium Forming			
Capital	640,800	756,900	811,300
Annual	309,400	348,400	381,800
Uranium Forming			
Capital	NA	NA	NA
Annual	NA	NA	NA
Zinc Forming			
Capital	C	C	C
Annual	C	C	C

Table XII-4 (Continued)

CAPITAL AND ANNUAL COST ESTIMATES FOR PSES OPTIONS
INDIRECT DISCHARGERS (\$1982)

Subcategory	Option 1	Option 2*	Option 3**
Zirconium-Hafnium Forming			
Capital	2,200	11,300	12,000
Annual	2,800	4,100	4,400
Metal Powders			
Capital	511,800	400,900	457,500
Annual	334,100	435,000	490,500

*Total cost to install Option 2 technology.

**Total cost to install Option 3 technology.

C - Confidential.

NA - Not applicable.

Table XII-5

NONFERROUS METALS FORMING POLLUTANT REDUCTION BENEFIT ESTIMATES (kg/yr)
 LEAD-TIN-BISMUTH FORMING SUBCATEGORY
 INDIRECT DISCHARGERS

Pollutant	Raw Waste	Option 1 Discharged	Option 1 Removed	Option 2 Discharged	Option 2 Removed	Option 3 Discharged	Option 3 Removed
Antimony	7.88	7.88	0.00	3.95	4.53	2.25	5.63
Arsenic	0.13	0.13	0.00	0.13	0.00	0.13	0.00
Beryllium	0.00	0.00	0.00	0.00	0.00	0.00	0.00
Cadmium	0.03	0.03	0.00	0.03	0.00	0.03	0.00
Chromium	19.00	2.36	16.65	0.40	18.60	0.33	18.67
Copper	2.39	2.39	0.00	2.39	0.00	1.86	0.53
Lead	177.11	3.37	173.75	0.57	176.54	0.38	176.73
Nickel	2.19	2.19	0.00	2.19	0.00	1.05	1.14
Zinc	1.23	1.23	0.00	1.23	0.00	1.10	0.13
TOTAL TOXIC METALS	209.97	19.57	190.39	10.29	199.67	7.14	202.83
Cyanide	0.33	0.33	0.00	0.33	0.00	0.33	0.00
TOTAL TOXICS	210.29	19.90	190.39	10.62	199.67	7.47	202.83
Aluminum	1.52	1.52	0.00	1.52	0.00	1.52	0.00
Ammonia	2.80	2.80	0.00	2.80	0.00	2.80	0.00
Cobalt	97.35	1.40	95.95	0.24	97.11	0.16	97.19
Fluoride	10.15	10.15	0.00	10.15	0.00	10.15	0.00
Iron	14.53	11.50	3.03	1.96	12.57	1.34	13.19
Magnesium	214.36	2.80	211.55	0.48	213.88	0.32	214.04
Manganese	0.95	0.95	0.00	0.76	0.19	0.67	0.28
Molybdenum	0.23	0.23	0.00	0.23	0.00	0.23	0.00
Tin	0.70	0.70	0.00	0.70	0.00	0.70	0.00
Titanium	0.43	0.43	0.00	0.43	0.00	0.43	0.00
Vanadium	0.38	0.38	0.00	0.38	0.00	0.38	0.00
TOTAL NONCONVENTIONALS	343.41	32.88	310.54	19.66	323.75	18.71	324.71
TSS	2,582.50	336.57	2,245.93	57.35	2,525.16	12.42	2,570.08
Oil and Grease	1,812.01	280.48	1,531.53	47.79	1,764.22	47.79	1,764.22
TOTAL CONVENTIONALS	4,394.51	617.05	3,777.47	105.13	4,289.38	60.21	4,334.30
TOTAL POLLUTANTS	4,948.22	669.82	4,278.40	135.41	4,812.81	86.39	4,861.83

2025

Table XII-6

NONFERROUS METALS FORMING POLLUTANT REDUCTION BENEFIT ESTIMATES (kg/yr)
MAGNESIUM FORMING SUBCATEGORY
INDIRECT DISCHARGERS

Pollutant	Raw Waste	Option 1 Discharged	Option 1 Removed	Option 2 Discharged	Option 2 Removed	Option 3 Discharged	Option 3 Removed
Antimony	0.00	0.00	0.00	0.00	0.00	0.00	0.00
Arsenic	0.00	0.00	0.00	0.00	0.00	0.00	0.00
Beryllium	0.03	0.03	0.00	0.03	0.00	0.03	0.00
Cadmium	0.00	0.00	0.00	0.00	0.00	0.00	0.00
Chromium	2,094.49	0.41	2,094.09	0.05	2,094.44	0.04	2,094.45
Copper	0.48	0.48	0.00	0.37	0.11	0.25	0.23
Lead	0.03	0.03	0.00	0.03	0.00	0.03	0.00
Nickel	0.00	0.00	0.00	0.00	0.00	0.00	0.00
Silver	0.00	0.00	0.00	0.00	0.00	0.00	0.00
Zinc	18.92	1.60	17.32	0.21	18.71	0.15	18.77
TOTAL TOXIC METALS	2,113.96	2.55	2,111.40	0.70	2,113.26	0.50	2,113.45
Cyanide	0.01	0.01	0.00	0.01	0.00	0.01	0.00
TOTAL TOXICS	2,113.96	2.56	2,111.40	0.70	2,113.26	0.51	2,113.45
Aluminum	16.61	10.89	5.72	1.44	15.17	0.96	15.66
Ammonia	115.78	115.78	0.00	115.78	0.00	115.78	0.00
Cobalt	0.75	0.24	0.51	0.03	0.72	0.02	0.73
Fluoride	14.26	14.26	0.00	9.30	4.96	9.30	4.96
Iron	1.02	1.02	0.00	0.26	0.76	0.18	0.84
Magnesium	2,064.41	0.49	2,063.92	0.06	2,064.34	0.04	2,064.36
Manganese	0.21	0.21	0.00	0.10	0.11	0.09	0.12
Molybdenum	0.00	0.00	0.00	0.00	0.00	0.00	0.00
Tin	0.00	0.00	0.00	0.00	0.00	0.00	0.00
Titanium	0.00	0.00	0.00	0.00	0.00	0.00	0.00
Vanadium	0.00	0.00	0.00	0.00	0.00	0.00	0.00
TOTAL NONCONVENTIONALS	2,213.04	142.89	2,070.15	126.98	2,086.06	126.37	2,086.67
TSS	762.24	58.33	703.91	7.69	754.55	1.67	760.57
Oil and Grease	117.17	48.60	68.56	6.41	110.76	6.41	110.76
TOTAL CONVENTIONALS	879.41	106.93	772.48	14.10	865.30	8.08	871.33
TOTAL POLLUTANTS	5,206.41	252.37	4,954.03	141.79	5,064.62	134.96	5,071.45

2026

Table XII-7

NONFERROUS METALS FORMING POLLUTANT REDUCTION BENEFIT ESTIMATES (kg/yr)
 NICKEL-COBALT FORMING SUBCATEGORY
 INDIRECT DISCHARGERS

Pollutant	Raw Waste	Option 1 Discharged	Option 1 Removed	Option 2 Discharged	Option 2 Removed	Option 3 Discharged	Option 3 Removed
Arsenic	3.04	3.04	0.00	3.04	0.00	3.04	0.00
Cadmium	781.65	162.31	619.33	19.37	762.27	12.02	769.63
Chromium	7,025.09	172.59	6,852.50	20.60	7,004.49	17.17	7,007.92
Copper	4,123.34	1,191.67	2,931.67	142.23	3,981.11	95.64	4,027.70
Lead	175.06	175.06	0.00	29.43	145.63	19.62	155.44
Nickel	80,285.64	1,520.40	78,765.24	181.47	80,104.17	53.95	80,231.69
Thallium	0.14	0.14	0.00	0.14	0.00	0.14	0.00
Zinc	449.57	449.57	0.00	80.93	368.65	56.40	393.17
TOTAL TOXIC METALS	92,843.46	3,674.77	89,168.69	477.20	92,366.26	257.97	92,585.49
Cyanide	0.07	0.07	0.00	0.07	0.00	0.07	0.00
TOTAL TOXICS	92,843.53	3,674.85	89,168.69	477.27	92,366.26	258.04	92,585.49
Aluminum	600.09	600.09	0.00	549.32	50.78	365.39	234.70
Ammonia	3,378.83	3,378.83	0.00	3,378.83	0.00	3,378.83	0.00
Cobalt	8,597.11	102.73	8,494.38	12.26	8,584.85	8.34	8,588.78
Fluoride	137,445.96	29,791.70	107,654.26	3,555.83	133,890.12	3,555.83	133,890.12
Iron	12,003.50	842.39	11,161.12	100.54	11,902.96	68.66	11,934.84
Molybdenum	1,388.27	1,388.27	0.00	345.77	1,042.50	230.52	1,157.76
Titanium	8,028.38	410.92	7,617.46	49.05	7,979.33	31.88	7,996.50
Vanadium	344.11	344.11	0.00	344.11	0.00	230.52	113.59
TOTAL NONCONVENTIONALS	171,791.26	36,859.05	134,932.22	8,335.72	163,455.54	7,869.98	163,921.29
TSS	272,293.43	24,655.20	247,638.23	2,942.76	269,350.67	637.60	271,655.83
Oil and Grease	256,443.38	20,546.00	235,897.38	2,452.30	253,991.08	2,452.30	253,991.08
TOTAL CONVENTIONALS	528,736.80	45,201.20	483,535.60	5,395.06	523,341.74	3,089.90	525,646.91
TOTAL POLLUTANTS	793,371.60	85,735.09	707,636.51	14,208.05	779,163.55	11,217.91	782,153.69

2027

Table XII-8

NONFERROUS METALS FORMING POLLUTANT REDUCTION BENEFIT ESTIMATES (kg/yr)
 PRECIOUS METALS FORMING SUBCATEGORY
 INDIRECT DISCHARGERS

Pollutant	Raw Waste	Option 1 Discharged	Option 1 Removed	Option 2 Discharged	Option 2 Removed	Option 3 Discharged	Option 3 Removed
Antimony	0.07	0.07	0.00	0.07	0.00	0.07	0.00
Arsenic	0.00	0.00	0.00	0.00	0.00	0.00	0.00
Cadmium	23.85	6.87	16.98	0.73	23.11	0.46	23.39
Chromium	2.55	2.55	0.00	0.78	1.77	0.65	1.90
Copper	78.88	50.42	28.46	5.39	73.49	3.62	75.26
Lead	1.84	1.84	0.00	1.12	0.72	0.74	1.09
Nickel	6.22	6.22	0.00	6.22	0.00	2.04	4.17
Selenium	0.00	0.00	0.00	0.00	0.00	0.00	0.00
Silver	3.43	3.43	0.00	0.93	2.50	0.06	3.37
Thallium	0.00	0.00	0.00	0.00	0.00	0.00	0.00
Zinc	24.37	24.37	0.00	3.07	21.31	2.14	22.23
TOTAL TOXIC METALS	141.21	95.77	45.44	18.30	122.90	9.79	131.42
Cyanide	48.55	6.09	42.47	0.65	47.90	0.44	48.12
TOTAL TOXICS	189.76	101.85	87.91	18.95	170.81	10.23	179.53
Aluminum	156.04	156.04	0.00	20.82	135.22	13.85	142.19
Ammonia	15.09	15.09	0.00	15.09	0.00	15.09	0.00
Cobalt	0.11	0.11	0.00	0.11	0.00	0.11	0.00
Fluoride	61.54	61.54	0.00	61.54	0.00	61.54	0.00
Iron	67.21	35.64	31.57	3.81	63.40	2.60	64.61
Magnesium	263.60	8.69	254.91	0.93	262.67	0.93	262.67
Manganese	11.96	11.96	0.00	1.49	10.47	1.30	10.65
Tin	0.03	0.03	0.00	0.03	0.00	0.03	0.00
Titanium	1.31	1.31	0.00	1.31	0.00	1.21	0.11
Vanadium	0.09	0.09	0.00	0.09	0.00	0.09	0.00
TOTAL NONCONVENTIONALS	576.98	290.51	286.48	105.22	471.76	96.75	480.23
TSS	7,576.10	1,043.22	6,532.89	111.53	7,464.57	24.17	7,551.94
Oil and Grease	3,721.96	869.35	2,852.62	92.95	3,629.02	92.95	3,692.02
TOTAL CONVENTIONALS	11,298.07	1,912.56	9,385.50	204.48	11,093.59	117.11	11,180.96
TOTAL POLLUTANTS	12,064.81	2,304.92	9,759.89	328.66	11,736.15	224.09	11,840.72

2028

Table XII-9

NONFERROUS METALS FORMING POLLUTANT REDUCTION BENEFIT ESTIMATES (kg/yr)
 REFRACTORY METALS FORMING SUBCATEGORY
 INDIRECT DISCHARGERS

Pollutant	Raw Waste	Option 1 Discharged	Option 1 Removed	Option 2 Discharged	Option 2 Removed	Option 3 Discharged	Option 3 Removed
Arsenic	0.00	0.00	0.00	0.00	0.00	0.00	0.00
Beryllium	0.00	0.00	0.00	0.00	0.00	0.00	0.00
Cadmium	1.38	1.38	0.00	0.60	0.78	0.48	0.90
Chromium	15.07	15.07	0.00	1.22	13.85	1.02	14.05
Copper	8.81	8.81	0.00	5.45	3.36	4.67	4.14
Lead	1.18	1.18	0.00	1.18	0.00	1.05	0.13
Nickel	240.40	186.07	54.33	10.77	229.64	3.20	237.20
Silver	0.00	0.00	0.00	0.00	0.00	0.00	0.00
Thallium	0.00	0.00	0.00	0.00	0.00	0.00	0.00
Zinc	3.23	3.23	0.00	2.95	0.29	2.54	0.70
TOTAL TOXIC METALS	270.07	215.74	54.33	22.17	247.90	12.96	257.11
Cyanide	0.00	0.00	0.00	0.00	0.00	0.00	0.00
TOTAL TOXICS	270.07	215.74	54.33	22.17	247.90	12.96	257.11
Aluminum	559.52	513.21	46.31	32.59	526.94	21.68	537.85
Ammonia	3.12	3.12	0.00	3.12	0.00	3.12	0.00
Cobalt	2.58	2.58	0.00	0.58	2.00	0.43	2.15
Fluoride	4,504.30	3,389.61	1,114.69	210.94	4,293.36	210.94	4,293.36
Iron	186.58	105.10	81.48	5.96	180.62	4.07	182.51
Magnesium	0.00	0.00	0.00	0.00	0.00	0.00	0.00
Manganese	0.00	0.00	0.00	0.00	0.00	0.00	0.00
Refractory Metals	110,589.90	592.70	109,997.19	17.15	110,572.74	12.00	110,577.90
Titanium	93.53	29.69	63.84	1.13	92.39	0.95	92.58
TOTAL NONCONVENTIONALS	115,939.53	4,636.02	111,303.51	271.48	115,668.05	253.18	115,686.35
TSS	52,773.67	5,066.29	47,707.38	174.57	52,599.10	37.82	52,735.85
Oil and Grease	355.69	355.69	0.00	103.33	252.36	103.33	252.36
TOTAL CONVENTIONALS	53,129.36	5,421.98	47,707.38	277.90	52,851.46	141.16	52,988.20
TOTAL POLLUTANTS	169,338.97	10,273.75	159,065.22	571.56	168,767.41	407.30	168,931.67

Table XII-10

NONFERROUS METALS FORMING POLLUTANT REDUCTION BENEFIT ESTIMATES (kg/yr)
 TITANIUM FORMING SUBCATEGORY
 INDIRECT DISCHARGERS

Pollutant	Raw Waste	Option 1 Discharged	Option 1 Removed	Option 2 Discharged	Option 2 Removed	Option 3 Discharged	Option 3 Removed
Arsenic	1.99	1.99	0.00	1.99	0.00	1.99	0.00
Cadmium	0.04	0.04	0.00	0.04	0.00	0.04	0.00
Chromium	24.99	24.99	0.00	3.47	21.52	2.89	22.10
Copper	18.42	18.42	0.00	18.42	0.00	16.13	2.29
Lead	209.91	44.88	165.03	4.96	204.95	3.31	206.60
Nickel	8.36	8.36	0.00	8.36	0.00	8.36	0.00
Thallium	0.07	0.07	0.00	0.07	0.00	0.07	0.00
Zinc	171.86	123.43	48.43	13.65	158.21	9.51	162.35
TOTAL TOXIC METALS	435.63	222.18	213.45	50.95	384.68	42.30	393.34
Cyanide	0.62	0.62	0.00	0.62	0.00	0.62	0.00
TOTAL TOXICS	436.25	222.80	213.45	51.57	384.68	42.91	393.34
Aluminum	7,183.93	837.84	6,346.10	92.62	7,091.31	61.61	7,122.32
Ammonia	3,542.22	3,542.22	0.00	3,542.22	0.00	3,542.22	0.00
Cobalt	134.47	18.70	115.77	2.07	132.41	1.41	133.07
Fluoride	124,028.77	5,423.49	118,605.28	599.58	123,429.19	599.58	123,429.19
Iron	33,225.34	153.35	33,071.98	16.95	33,208.38	11.58	33,213.76
Molybdenum	574.49	527.39	47.10	58.30	516.18	38.87	535.62
Tantalum	0.00	0.00	0.00	0.00	0.00	0.00	0.00
Titanium	75,702.90	74.81	75,628.09	8.27	75,694.63	5.38	75,697.53
Tungsten	0.00	0.00	0.00	0.00	0.00	0.00	0.00
Vanadium	1,630.12	527.39	1,102.73	58.30	1,571.81	38.87	1,591.25
Zirconium	0.00	0.00	0.00	0.00	0.00	0.00	0.00
Hafnium	0.00	0.00	0.00	0.00	0.00	0.00	0.00
Columbium	0.00	0.00	0.00	0.00	0.00	0.00	0.00
TOTAL NONCONVENTIONALS	246,022.24	11,105.19	234,917.05	4,378.33	241,643.91	4,299.51	241,722.73
TSS	14,541.91	4,488.40	10,053.51	496.20	14,045.71	107.51	14,434.40
Oil and Grease	871.33	871.33	0.00	413.50	457.83	413.50	457.83
TOTAL CONVENTIONALS	15,413.24	5,359.74	10,053.51	909.71	14,503.54	521.01	14,892.23
TOTAL POLLUTANTS	261,871.73	16,687.72	245,184.01	5,339.60	256,532.13	4,863.44	257,008.29

2030

Table XII-11

NONFERROUS METALS FORMING POLLUTANT REDUCTION BENEFIT ESTIMATES (kg/yr)
 ZIRCONIUM-HAFNIUM FORMING SUBCATEGORY
 INDIRECT DISCHARGERS

Pollutant	Raw Waste	Option 1 Discharged	Option 1 Removed	Option 2 Discharged	Option 2 Removed	Option 3 Discharged	Option 3 Removed
Arsenic	0.00	0.00	0.00	0.00	0.00	0.00	0.00
Cadmium	0.00	0.00	0.00	0.00	0.00	0.00	0.00
Chromium	0.16	0.13	0.02	0.02	0.14	0.01	0.14
Copper	0.06	0.06	0.00	0.06	0.00	0.06	0.00
Lead	0.00	0.00	0.00	0.00	0.00	0.00	0.00
Nickel	0.10	0.10	0.00	0.10	0.00	0.05	0.05
Thallium	0.00	0.00	0.00	0.00	0.00	0.00	0.00
Zinc	1.21	0.52	0.69	0.07	1.15	0.05	1.17
TOTAL TOXIC METALS	1.53	0.82	0.71	0.25	1.29	0.17	1.36
Cyanide	0.02	0.02	0.00	0.01	0.00	0.01	0.01
Dichloromethane	0.00	0.00	0.00	0.00	0.00	0.00	0.00
Toluene	0.00	0.00	0.00	0.00	0.00	0.00	0.00
TOTAL TOXICS	1.55	0.84	0.71	0.26	1.29	0.18	1.37
Aluminum	1.42	1.42	0.00	0.47	0.96	0.31	1.11
Ammonia	0.40	0.40	0.00	0.40	0.00	0.40	0.00
Cobalt	0.01	0.01	0.00	0.01	0.00	0.01	0.00
Fluoride	26.89	23.04	3.85	3.01	23.88	3.01	23.88
Iron	1.52	0.65	0.87	0.09	1.44	0.06	1.46
Molybdenum	0.04	0.04	0.00	0.04	0.00	0.04	0.00
Titanium	0.00	0.00	0.00	0.00	0.00	0.00	0.00
Vanadium	0.09	0.09	0.00	0.09	0.00	0.09	0.00
Zirconium	93.65	11.47	82.17	1.50	92.15	1.00	92.65
TOTAL NONCONVENTIONALS	124.03	37.14	86.89	5.61	118.42	4.92	119.11
TSS	75.70	19.07	56.63	2.49	73.21	0.54	75.16
Oil and Grease	898.86	15.89	882.97	2.08	896.78	2.08	896.78
TOTAL CONVENTIONALS	974.56	34.96	939.60	4.57	969.99	2.62	971.94
TOTAL POLLUTANTS	1,100.14	72.94	1,027.21	10.44	1,089.70	7.72	1,092.42

2031

Table XII-12

NONFERROUS METALS FORMING POLLUTANT REDUCTION BENEFIT ESTIMATES (kg/yr)
METAL POWDERS SUBCATEGORY
INDIRECT DISCHARGERS

Pollutant	Raw Waste	Option 1 Discharged	Option 1 Removed	Option 2 Discharged	Option 2 Removed	Option 3 Discharged	Option 3 Removed
Antimony	0.38	0.38	0.00	0.38	0.00	0.38	0.00
Arsenic	0.61	0.61	0.00	0.61	0.00	0.61	0.00
Cadmium	0.00	0.00	0.00	0.00	0.00	0.00	0.00
Chromium	1.88	1.88	0.00	1.88	0.00	1.88	0.00
Copper	821.05	54.25	766.80	16.24	804.80	10.92	810.12
Lead	164.50	11.22	153.27	3.36	161.14	2.24	162.26
Nickel	39.89	39.89	0.00	20.73	19.17	6.16	33.73
Silver	0.00	0.00	0.00	0.00	0.00	0.00	0.00
Thallium	0.00	0.00	0.00	0.00	0.00	0.00	0.00
Zinc	66.88	30.86	36.01	9.24	57.64	6.44	60.44
TOTAL TOXIC METALS	1,095.17	139.09	956.09	52.44	1,042.74	28.63	1,066.55
Cyanide	3.13	3.13	0.00	1.96	1.17	1.32	1.81
TOTAL TOXICS	1,098.30	142.21	956.09	54.40	1,043.91	29.94	1,068.36
Aluminum	399.15	209.50	189.65	62.74	336.41	41.73	357.42
Ammonia	15.88	15.88	0.00	15.88	0.00	15.88	0.00
Cobalt	0.01	0.01	0.00	0.01	0.00	0.01	0.00
Fluoride	39.73	39.73	0.00	39.73	0.00	39.73	0.00
Iron	1,772.76	38.35	1,734.41	11.48	1,761.28	7.84	1,764.92
Magnesium	74.00	9.35	64.65	2.80	71.20	1.88	72.13
Molybdenum	0.57	0.57	0.00	0.57	0.00	0.57	0.00
Tin	78.42	78.42	0.00	29.97	48.46	19.89	58.54
Titanium	30.77	18.71	12.07	5.60	25.17	3.64	27.13
Vanadium	0.32	0.32	0.00	0.32	0.00	0.32	0.00
TOTAL NONCONVENTIONALS	2,411.62	410.84	2,000.78	169.11	2,242.52	131.49	2,280.13
TSS	36,700.58	1,122.32	35,578.26	336.10	36,364.48	72.82	36,627.76
Oil and Grease	15,867.35	935.27	14,932.09	280.08	15,587.27	280.08	15,587.27
TOTAL CONVENTIONALS	52,567.93	2,057.58	50,510.35	616.18	51,951.75	352.90	52,215.03
TOTAL POLLUTANTS	56,077.86	2,610.64	53,467.22	839.68	55,238.18	514.34	55,563.52

2032

Table XII-13

LEAD-TIN-BISMUTH FORMING SUBCATEGORY
 PRETREATMENT STANDARDS FOR EXISTING SOURCES

PSES
 Lead-Tin-Bismuth Forming
 Rolling Spent Emulsions

Pollutant or pollutant property	Maximum for any one day	Maximum for monthly average
mg/off-kg (lb/million off-lbs) of lead-tin-bismuth rolled with emulsions		
*Antimony	.067	.030
*Lead	.010	.005

PSES
 Lead-Tin-Bismuth Forming
 Rolling Spent Soap Solutions

Pollutant or pollutant property	Maximum for any one day	Maximum for monthly average
mg/off-kg (lb/million off-lbs) of lead-tin-bismuth rolled with soap solutions		
*Antimony	.124	.055
*Lead	.018	.009

PSES
 Lead-Tin-Bismuth Forming
 Drawing Spent Neat Oils

There shall be no discharge of process wastewater
 pollutants.

Table XII-13 (Continued)

LEAD-TIN-BISMUTH FORMING SUBCATEGORY
 PRETREATMENT STANDARDS FOR EXISTING SOURCES

PSES

Lead-Tin-Bismuth Forming
 Drawing Spent Emulsions

Pollutant or pollutant property	Maximum for any one day	Maximum for monthly average
mg/off-kg (lb/million off-lbs) of lead-tin-bismuth drawn with emulsions		
*Antimony	.076	.034
*Lead	.011	.005

PSES

Lead-Tin-Bismuth Forming
 Drawing Spent Soap Solutions

Pollutant or pollutant property	Maximum for any one day	Maximum for monthly average
mg/off-kg (lb/million off-lbs) of lead-tin-bismuth drawn with soap solutions		
*Antimony	.021	.010
*Lead	.003	.001

PSES

Lead-Tin-Bismuth Forming
 Extrusion Press or Solution Heat Treatment Contact
 Cooling Water

Pollutant or pollutant property	Maximum for any one day	Maximum for monthly average
mg/off-kg (lb/million off-lbs) of lead-tin-bismuth heat treated		
*Antimony	.413	.185
*Lead	.061	.029

Table XII-13 (Continued)

LEAD-TIN-BISMUTH FORMING SUBCATEGORY
 PRETREATMENT STANDARDS FOR EXISTING SOURCES

PSES

Lead-Tin-Bismuth Forming
 Extrusion Press Hydraulic Fluid Leakage

Pollutant or pollutant property	Maximum for any one day	Maximum for monthly average
mg/off-kg (lb/million off-lbs) of lead-tin-bismuth extruded		
*Antimony	.158	.070
*Lead	.023	.011

PSES

Lead-Tin-Bismuth Forming
 Swaging Spent Emulsions

Pollutant or pollutant property	Maximum for any one day	Maximum for monthly average
mg/off-kg (lb/million off-lbs) of lead-tin-bismuth swaged with emulsions		
*Antimony	.0051	.0023
*Lead	.0008	.0004

PSES

Lead-Tin-Bismuth Forming
 Continuous Strip Casting Contact Cooling Water

Pollutant or pollutant property	Maximum for any one day	Maximum for monthly average
mg/off-kg (lb/million off-lbs) of lead-tin-bismuth cast by the continuous strip method		
*Antimony	.0029	.0013
*Lead	.0004	.0002

Table XII-13 (Continued)

LEAD-TIN-BISMUTH FORMING SUBCATEGORY
PRETREATMENT STANDARDS FOR EXISTING SOURCES

PSES
Lead-Tin-Bismuth Forming
Semi-Continuous Ingot Casting Contact Cooling Water

Pollutant or pollutant property	Maximum for any one day	Maximum for monthly average
mg/off-kg (lb/million off-lbs) of lead-tin-bismuth ingot cast by the semi-continuous method		
*Antimony	.008	.004
*Lead	.001	.001

PSES
Lead-Tin-Bismuth Forming
Shot Casting Contact Cooling Water

Pollutant or pollutant property	Maximum for any one day	Maximum for monthly average
mg/off-kg (lb/million off-lbs) of lead-tin-bismuth shot cast		
*Antimony	.107	.048
*Lead	.016	.007

PSES
Lead-Tin-Bismuth Forming
Shot-Forming Wet Air Pollution Control Blowdown

Pollutant or pollutant property	Maximum for any one day	Maximum for monthly average
mg/off-kg (lb/million off-lbs) of lead-tin-bismuth shot formed		
*Antimony	.169	.075
*Lead	.025	.012

Table XII-13 (Continued)

LEAD-TIN-BISMUTH FORMING SUBCATEGORY
 PRETREATMENT STANDARDS FOR EXISTING SOURCES

PSES

Lead-Tin-Bismuth Forming
 Alkaline Cleaning Spent Baths

Pollutant or pollutant property	Maximum for any one day	Maximum for monthly average
mg/off-kg (lb/million off-lbs) of lead-tin-bismuth alkaline cleaned		
*Antimony	.345	.154
*Lead	.050	.024

PSES

Lead-Tin-Bismuth Forming
 Alkaline Cleaning Rinse

Pollutant or pollutant property	Maximum for any one day	Maximum for monthly average
mg/off-kg (lb/million off-lbs) of lead-tin-bismuth alkaline cleaned		
*Antimony	.678	.302
*Lead	.099	.047

PSES

Lead-Tin-Bismuth Forming
 Degreasing Spent Solvents

There shall be no discharge of process wastewater
 pollutants.

Table XII-14

MAGNESIUM FORMING SUBCATEGORY
 PRETREATMENT STANDARDS FOR EXISTING SOURCES

PSES
 Magnesium Forming
 Rolling Spent Emulsions

Pollutant or pollutant property	Maximum for any one day	Maximum for monthly average
mg/off-kg (lb/million off-lbs) of magnesium rolled with emulsions		
*Chromium	.033	.013
*Zinc	.109	.046
*Ammonia	9.950	4.370
*Fluoride	4.440	1.970
Magnesium	.007	---

PSES
 Magnesium Forming
 Forging Spent Lubricants

There shall be no discharge of process wastewater
 pollutants.

PSES
 Magnesium Forming
 Forging Contact Cooling Water

Pollutant or pollutant property	Maximum for any one day	Maximum for monthly average
mg/off-kg (lb/million off-lbs) of forged magnesium cooled with water		
*Chromium	.127	.052
*Zinc	.422	.176
*Ammonia	38.500	17.000
*Fluoride	17.200	7.630
Magnesium	.029	---

Table XII-14 (Continued)

MAGNESIUM FORMING SUBCATEGORY
 PRETREATMENT STANDARDS FOR EXISTING SOURCES

PSES
 Magnesium Forming
 Forging Equipment Cleaning Wastewater

Pollutant or pollutant property	Maximum for any one day	Maximum for monthly average
mg/off-kg (lb/million off-lbs) of magnesium forged		
*Chromium	.0018	.0007
*Zinc	.0058	.0024
*Ammonia	.5320	.2340
*Fluoride	.2380	.1060
Magnesium	.0004	---

PSES
 Magnesium Forming
 Direct Chill Casting Contact Cooling Water

Pollutant or pollutant property	Maximum for any one day	Maximum for monthly average
mg/off-kg (lb/million off-lbs) of magnesium cast with direct chill methods		
*Chromium	1.740	.711
*Zinc	5.770	2.410
*Ammonia	527.000	232.000
*Fluoride	235.000	104.000
Magnesium	.395	---

Table XII-14 (Continued)

MAGNESIUM FORMING SUBCATEGORY
 PRETREATMENT STANDARDS FOR EXISTING SOURCES

PSES
 Magnesium Forming
 Surface Treatment Spent Baths

Pollutant or pollutant property	Maximum for any one day	Maximum for monthly average
mg/off-kg (lb/million off-lbs) of magnesium surface treated		
*Chromium	.205	.084
*Zinc	.681	.284
*Ammonia	62.100	27.300
*Fluoride	27.700	12.300
Magnesium	.047	---

PSES
 Magnesium Forming
 Surface Treatment Rinse

Pollutant or pollutant property	Maximum for any one day	Maximum for monthly average
mg/off-kg (lb/million off-lbs) of magnesium surface treated		
*Chromium	.832	.340
*Zinc	2.760	1.150
*Ammonia	252.000	111.000
*Fluoride	113.000	49.900
Magnesium	.189	---

Table XII-14 (Continued)

MAGNESIUM FORMING SUBCATEGORY
 PRETREATMENT STANDARDS FOR EXISTING SOURCES

PSES
 Magnesium Forming
 Sawing or Grinding Spent Emulsions

Pollutant or pollutant property	Maximum for any one day	Maximum for monthly average
mg/off-kg (lb/million off-lbs) of magnesium sawed or ground		
*Chromium	.009	.004
*Zinc	.029	.012
*Ammonia	2.600	1.140
*Fluoride	1.160	.515
Magnesium	.002	---

PSES
 Magnesium Forming
 Degreasing Spent Solvents

There shall be no discharge of process wastewater
 pollutants.

PSES
 Magnesium Forming
 Wet Air Pollution Control Blowdown

Pollutant or pollutant property	Maximum for any one day	Maximum for monthly average
mg/off-kg (lb/million off-lbs) of magnesium formed		
*Chromium	.273	.112
*Zinc	.904	.378
*Ammonia	82.500	36.300
*Fluoride	36.900	16.400
Magnesium	.062	---

Table XII-15

NICKEL-COBALT FORMING SUBCATEGORY
 PRETREATMENT STANDARDS FOR EXISTING SOURCES

PSES
 Nickel-Cobalt Forming
 Rolling Spent Neat Oils

There shall be no discharge of process wastewater
 pollutants.

PSES
 Nickel-Cobalt Forming
 Rolling Spent Emulsions

Pollutant or pollutant property	Maximum for any one day	Maximum for monthly average
mg/off-kg (lb/million off-lbs) of nickel-cobalt rolled with emulsions		
Cadmium	.034	.014
*Chromium	.063	.026
Copper	.218	.104
Lead	.048	.022
*Nickel	.094	.063
Zinc	.174	.071
*Fluoride	10.100	4.490

PSES
 Nickel-Cobalt Forming
 Rolling Contact Cooling Water

Pollutant or pollutant property	Maximum for any one day	Maximum for monthly average
mg/off-kg (lb/million off-lbs) of nickel-cobalt rolled with water		
Cadmium	.015	.006
*Chromium	.028	.011
Copper	.097	.046
Lead	.021	.010
*Nickel	.042	.028
Zinc	.077	.032
*Fluoride	4.490	1.990

Table XII-15 (Continued)

NICKEL-COBALT FORMING SUBCATEGORY
 PRETREATMENT STANDARDS FOR EXISTING SOURCES

PSES
 Nickel-Cobalt Forming
 Tube Reducing Spent Lubricants

There shall be no discharge of process wastewater pollutants.

PSES
 Nickel-Cobalt Forming
 Drawing Spent Neat Oils

There shall be no discharge of process wastewater pollutants.

PSES
 Nickel-Cobalt Forming
 Drawing Spent Emulsions

Pollutant or pollutant property	Maximum for any one day	Maximum for monthly average
mg/off-kg (lb/million off-lbs) of nickel-cobalt drawn with emulsions		
Cadmium	.019	.008
*Chromium	.035	.014
Copper	.122	.058
Lead	.027	.012
*Nickel	.053	.035
Zinc	.097	.040
*Fluoride	5.680	2.520

PSES
 Nickel-Cobalt Forming
 Extrusion Spent Lubricants

There shall be no discharge of process wastewater pollutants.

Table XII-15 (Continued)

NICKEL-COBALT FORMING SUBCATEGORY
 PRETREATMENT STANDARDS FOR EXISTING SOURCES

PSES

Nickel-Cobalt Forming

Extrusion Press or Solution Heat Treatment Contact

Cooling Water

Pollutant or pollutant property	Maximum for any one day	Maximum for monthly average
mg/off-kg (lb/million off-lbs) of nickel-cobalt heat treated		
Cadmium	.017	.007
*Chromium	.031	.013
Copper	.107	.051
Lead	.023	.011
*Nickel	.046	.031
Zinc	.085	.035
*Fluoride	4.950	2.200

PSES

Nickel-Cobalt Forming

Extrusion Press Hydraulic Fluid Leakage

Pollutant or pollutant property	Maximum for any one day	Maximum for monthly average
mg/off-kg (lb/million off-lbs) of nickel-cobalt extruded		
Cadmium	.046	.019
*Chromium	.086	.035
Copper	.297	.142
Lead	.065	.030
*Nickel	.128	.086
Zinc	.237	.098
*Fluoride	13.800	6.130

PSES

Nickel-Cobalt Forming

Forging Spent Lubricants

There shall be no discharge of process wastewater
 pollutants.

Table XII-15 (Continued)

NICKEL-COBALT FORMING SUBCATEGORY
 PRETREATMENT STANDARDS FOR EXISTING SOURCES

PSES

Nickel-Cobalt Forming
 Forging Contact Cooling Water

Pollutant or pollutant property	Maximum for any one day	Maximum for monthly average
mg/off-kg (lb/million off-lbs) of forged nickel-cobalt cooled with water		
Cadmium	.009	.004
*Chromium	.018	.007
Copper	.061	.029
Lead	.013	.006
*Nickel	.026	.018
Zinc	.048	.020
*Fluoride	2.820	1.250

PSES

Nickel-Cobalt Forming
 Forging Equipment Cleaning Wastewater

Pollutant or pollutant property	Maximum for any one day	Maximum for monthly average
mg/off-kg (lb/million off-lbs) of nickel-cobalt forged		
Cadmium	.0008	.0003
*Chromium	.0015	.0006
Copper	.0051	.0024
Lead	.0011	.0005
*Nickel	.0022	.0015
Zinc	.0041	.0017
*Fluoride	.2380	.1060

Table XII-15 (Continued)

NICKEL-COBALT FORMING SUBCATEGORY
 PRETREATMENT STANDARDS FOR EXISTING SOURCES

PSES
 Nickel-Cobalt Forming
 Forging Press Hydraulic Fluid Leakage

Pollutant or pollutant property	Maximum for any one day	Maximum for monthly average
mg/off-kg (lb/million off-lbs) of nickel-cobalt forged		
Cadmium	.037	.015
*Chromium	.069	.028
Copper	.240	.114
Lead	.052	.024
*Nickel	.103	.069
Zinc	.191	.079
*Fluoride	11.100	4.940

PSES
 Nickel-Cobalt Forming
 Metal Powder Production Atomization Wastewater

Pollutant or pollutant property	Maximum for any one day	Maximum for monthly average
mg/off-kg (lb/million off-lbs) of nickel-cobalt metal powder atomized		
Cadmium	.524	.210
*Chromium	.970	.393
Copper	3.360	1.600
Lead	.734	.341
*Nickel	1.440	.970
Zinc	2.670	1.100
*Fluoride	156.000	69.200

Table XII-15 (Continued)

NICKEL-COBALT FORMING SUBCATEGORY
 PRETREATMENT STANDARDS FOR EXISTING SOURCES

PSES
 Nickel-Cobalt Forming
 Stationary Casting Contact Cooling Water

Pollutant or pollutant property	Maximum for any one day	Maximum for monthly average
mg/off-kg (lb/million off-lbs) of nickel-cobalt cast with stationary casting methods		
Cadmium	.242	.097
*Chromium	.448	.182
Copper	1.550	.738
Lead	.339	.158
*Nickel	.666	.448
Zinc	1.240	.508
*Fluoride	72.000	32.000

PSES
 Nickel-Cobalt Forming
 Vacuum Melting Steam Condensate

There shall be no allowance for the discharge of
 process wastewater pollutants.

PSES
 Nickel-Cobalt Forming
 Annealing and Solution Heat Treatment Contact Cooling Water

There shall be no allowance for the discharge of
 process wastewater pollutants.

Table XII-15 (Continued)

NICKEL-COBALT FORMING SUBCATEGORY
 PRETREATMENT STANDARDS FOR EXISTING SOURCES

PSES
 Nickel-Cobalt Forming
 Surface Treatment Spent Baths

Pollutant or pollutant property	Maximum for any one day	Maximum for monthly average
mg/off-kg (lb/million off-lbs) of nickel-cobalt surface treated		
Cadmium	.187	.075
*Chromium	.346	.140
Copper	1.200	.571
Lead	.262	.122
*Nickel	.514	.346
Zinc	.954	.393
*Fluoride	55.700	24.700

PSES
 Nickel-Cobalt Forming
 Surface Treatment Rinse

Pollutant or pollutant property	Maximum for any one day	Maximum for monthly average
mg/off-kg (lb/million off-lbs) of nickel-cobalt surface treated		
Cadmium	.472	.189
*Chromium	.873	.354
Copper	3.020	1.440
Lead	.661	.307
*Nickel	1.300	.873
Zinc	2.410	.991
*Fluoride	141.000	62.300

Table XII-15(Continued)

NICKEL-COBALT FORMING SUBCATEGORY
 PRETREATMENT STANDARDS FOR EXISTING SOURCES

PSES

Nickel-Cobalt Forming
 Ammonia Rinse

Pollutant or pollutant property	Maximum for any one day	Maximum for monthly average
mg/off-kg (lb/million off-lbs) of nickel-cobalt treated with ammonia solution		
Cadmium	.003	.001
*Chromium	.005	.002
Copper	.019	.009
Lead	.004	.002
*Nickel	.008	.005
Zinc	.015	.006
*Fluoride	.881	.391

PSES

Nickel-Cobalt Forming
 Alkaline Cleaning Spent Baths

Pollutant or pollutant property	Maximum for any one day	Maximum for monthly average
mg/off-kg (lb/million off-lbs) of nickel-cobalt alkaline cleaned		
Cadmium	.007	.003
*Chromium	.013	.005
Copper	.043	.021
Lead	.009	.004
*Nickel	.019	.013
Zinc	.035	.014
*Fluoride	2.020	.895

Table XII-15 (Continued)

NICKEL-COBALT FORMING SUBCATEGORY
 PRETREATMENT STANDARDS FOR EXISTING SOURCES

PSES
 Nickel-Cobalt Forming
 Alkaline Cleaning Rinse

Pollutant or pollutant property	Maximum for any one day	Maximum for monthly average
mg/off-kg (lb/million off-lbs) of nickel-cobalt alkaline cleaned		
Cadmium	.047	.019
*Chromium	.086	.035
Copper	.298	.142
Lead	.065	.030
*Nickel	.128	.086
Zinc	.238	.098
*Fluoride	13.900	6.150

PSES
 Nickel-Cobalt Forming
 Molten Salt Rinse

Pollutant or pollutant property	Maximum for any one day	Maximum for monthly average
mg/off-kg (lb/million off-lbs) of nickel-cobalt treated with molten salt		
Cadmium	.169	.068
*Chromium	.312	.127
Copper	1.080	.515
Lead	.237	.110
*Nickel	.464	.312
Zinc	.861	.355
*Fluoride	50.200	22.300

Table XII-15 (Continued)

NICKEL-COBALT FORMING SUBCATEGORY
 PRETREATMENT STANDARDS FOR EXISTING SOURCES

PSES
 Nickel-Cobalt Forming
 Sawing or Grinding Spent Emulsions

Pollutant or pollutant property	Maximum for any one day	Maximum for monthly average
mg/off-kg (lb/million off-lbs) of nickel-cobalt sawed or ground with emulsions		
Cadmium	.008	.003
*Chromium	.015	.006
Copper	.051	.024
Lead	.011	.005
*Nickel	.022	.015
Zinc	.040	.017
*Fluoride	2.350	1.040

PSES
 Nickel-Cobalt Forming
 Sawing or Grinding Rinse

Pollutant or pollutant property	Maximum for any one day	Maximum for monthly average
mg/off-kg (lb/million off-lbs) of sawed or ground nickel-cobalt rinsed		
Cadmium	.036	.015
*Chromium	.067	.027
Copper	.232	.111
Lead	.051	.024
*Nickel	.100	.067
Zinc	.185	.076
*Fluoride	10.800	4.780

Table XII-15 (Continued)

NICKEL-COBALT FORMING SUBCATEGORY
 PRETREATMENT STANDARDS FOR EXISTING SOURCES

PSES
 Nickel-Cobalt Forming
 Steam Cleaning Condensate

Pollutant or pollutant property	Maximum for any one day	Maximum for monthly average
mg/off-kg (lb/million off-lbs) of nickel-cobalt steam cleaned		
Cadmium	.006	.002
*Chromium	.011	.005
Copper	.039	.018
Lead	.008	.004
*Nickel	.017	.011
Zinc	.031	.013
*Fluoride	1.790	.795

PSES
 Nickel-Cobalt Forming
 Hydrostatic Tube Testing and Ultrasonic Testing Wastewater

There shall be no allowance for the discharge of
 process wastewater pollutants.

PSES
 Nickel-Cobalt Forming
 Dye Penetrant Testing Wastewater

Pollutant or pollutant property	Maximum for any one day	Maximum for monthly average
mg/off-kg (lb/million off-lbs) of nickel-cobalt tested with dye penetrant methods		
Cadmium	.043	.017
*Chromium	.079	.032
Copper	.273	.130
Lead	.060	.028
*Nickel	.117	.079
Zinc	.217	.090
*Fluoride	12.700	5.630

Table XII-15 (Continued)

NICKEL-COBALT FORMING SUBCATEGORY
 PRETREATMENT STANDARDS FOR EXISTING SOURCES

PSES
 Nickel-Cobalt Forming
 Miscellaneous Wastewater Sources

Pollutant or pollutant property	Maximum for any one day	Maximum for monthly average
mg/off-kg (lb/million off-lbs) of nickel-cobalt formed		
Cadmium	.049	.020
*Chromium	.091	.037
Copper	.315	.150
Lead	.069	.032
*Nickel	.136	.091
Zinc	.251	.104
*Fluoride	14.700	6.500

PSES
 Nickel-Cobalt Forming
 Degreasing Spent Solvents

There shall be no discharge of process wastewater
 pollutants.

PSES
 Nickel-Cobalt Forming
 Wet Air Pollution Control Blowdown

Pollutant or pollutant property	Maximum for any one day	Maximum for monthly average
mg/off-kg (lb/million off-lbs) of nickel-cobalt formed		
Cadmium	.162	.065
*Chromium	.300	.122
Copper	1.040	.494
Lead	.227	.106
*Nickel	.446	.300
Zinc	.826	.340
*Fluoride	48.200	21.400

Table XII-15 (Continued)

NICKEL-COBALT FORMING SUBCATEGORY
 PRETREATMENT STANDARDS FOR EXISTING SOURCES

PSES
 Nickel-Cobalt Forming
 Electrocoating Rinse

Pollutant or pollutant property	Maximum for any one day	Maximum for monthly average
mg/off-kg (lb/million off-lbs) of nickel-cobalt electrocoated		
Cadmium	.674	.270
*Chromium	1.250	.506
Copper	4.320	2.060
Lead	.944	.438
*Nickel	1.860	1.250
Zinc	3.440	1.420
*Fluoride	201.000	89.000

Table XII-16

PRECIOUS METALS FORMING SUBCATEGORY
 PRETREATMENT STANDARDS FOR EXISTING SOURCES

PSES
 Precious Metals Forming
 Rolling Spent Neat Oils

There shall be no discharge of process wastewater pollutants.

PSES
 Precious Metals Forming
 Rolling Spent Emulsions

Pollutant or pollutant property	Maximum for any 'one day	Maximum for monthly average
mg/off-kg (lb/million off-lbs) of precious metals rolled with emulsions		
*Cadmium	.026	.012
Chromium	.034	.014
*Copper	.147	.077
*Cyanide ^N	.022	.009
*Lead	.032	.015
Nickel	.148	.098
*Silver	.032	.013
Zinc	.113	.047

PSES
 Precious Metals Forming
 Drawing Spent Neat Oils

There shall be no discharge of process wastewater pollutants.

Table XII-16 (Continued)

PRECIOUS METALS FORMING SUBCATEGORY
 PRETREATMENT STANDARDS FOR EXISTING SOURCES

PSES
 Precious Metals Forming
 Drawing Spent Emulsions

Pollutant or pollutant property	Maximum for any one day	Maximum for monthly average
mg/off-kg (lb/million off-lbs) of precious metals drawn with emulsions		
*Cadmium	.016	.007
Chromium	.021	.009
*Copper	.090	.048
*Cyanide	.014	.006
*Lead	.020	.010
Nickel	.091	.060
*Silver	.020	.008
Zinc	.069	.029

PSES
 Precious Metals Forming
 Drawing Spent Soap Solutions

Pollutant or pollutant property	Maximum for any one day	Maximum for monthly average
mg/off-kg (lb/million off-lbs) of precious metals drawn with soap solutions		
*Cadmium	.0011	.0005
Chromium	.0014	.0006
*Copper	.0059	.0031
*Cyanide	.0009	.0004
*Lead	.0013	.0006
Nickel	.0060	.0040
*Silver	.0013	.0005
Zinc	.0046	.0019

Table XII-16 (Continued)

PRECIOUS METALS FORMING SUBCATEGORY
 PRETREATMENT STANDARDS FOR EXISTING SOURCES

PSES
 Precious Metals Forming
 Metal Powder Production Atomization Wastewater

Pollutant or pollutant property	Maximum for any one day	Maximum for monthly average
mg/off-kg (lb/million off-lbs) of precious metals powder wet atomized		
*Cadmium	2.270	1.000
Chromium	2.940	1.200
*Copper	12.700	6.680
*Cyanide	1.940	.802
*Lead	2.810	1.340
Nickel	12.800	8.490
*Silver	2.740	1.140
Zinc	9.750	4.080

PSES
 Precious Metals Forming
 Direct Chill Casting Contact Cooling Water

Pollutant or pollutant property	Maximum for any one day	Maximum for monthly average
mg/off-kg (lb/million off-lbs) of precious metals cast by the direct chill method		
*Cadmium	.367	.162
Chromium	.475	.195
*Copper	2.050	1.080
*Cyanide	.313	.130
*Lead	.454	.216
Nickel	2.080	1.370
*Silver	.443	.184
Zinc	1.580	.659

Table XII-16 (Continued)

PRECIOUS METALS FORMING SUBCATEGORY
 PRETREATMENT STANDARDS FOR EXISTING SOURCES

PSES
 Precious Metals Forming
 Shot Casting Contact Cooling Water

Pollutant or pollutant property	Maximum for any one day	Maximum for monthly average
<hr/>		
mg/off-kg (lb/million off-lbs) of precious metals shot cast		
*Cadmium	.125	.055
Chromium	.162	.066
*Copper	.698	.367
*Cyanide	.107	.044
*Lead	.154	.073
Nickel	.705	.466
*Silver	.151	.062
Zinc	.536	.224

PSES
 Precious Metals Forming
 Stationary Casting Contact Cooling Water

There shall be no discharge of process wastewater
 pollutants.

PSES
 Precious Metals Forming
 Semi-Continuous and Continuous Casting Contact Cooling
 Water

Pollutant or pollutant property	Maximum for any one day	Maximum for monthly average
<hr/>		
mg/off-kg (lb/million off-lbs) of precious metals cast by the semi-continuous or continuous method		
*Cadmium	.350	.155
Chromium	.453	.186
*Copper	1.960	1.030
*Cyanide	.299	.124
*Lead	.433	.206
Nickel	1.980	1.310
*Silver	.423	.175
Zinc	1.510	.629

Table XII-16 (Continued)

PRECIOUS METALS FORMING SUBCATEGORY
 PRETREATMENT STANDARDS FOR EXISTING SOURCES

PSES
 Precious Metals Forming
 Heat Treatment Contact Cooling Water

Pollutant or pollutant property	Maximum for any one day	Maximum for monthly average
mg/off-kg (lb/million off-lbs) of extruded precious metals heat treated		
*Cadmium	.142	.063
Chromium	.184	.075
*Copper	.793	.417
*Cyanide	.121	.050
*Lead	.175	.083
Nickel	.801	.530
*Silver	.171	.071
Zinc	.609	.255

PSES
 Precious Metals Forming
 Surface Treatment Spent Baths

Pollutant or pollutant property	Maximum for any one day	Maximum for monthly average
mg/off-kg (lb/million off-lbs) of precious metals surface treated		
*Cadmium	.033	.015
Chromium	.042	.017
*Copper	.183	.096
*Cyanide	.028	.012
*Lead	.041	.019
Nickel	.185	.123
*Silver	.040	.016
Zinc	.141	.059

Table XII-16 (Continued)

PRECIOUS METALS FORMING SUBCATEGORY
 PRETREATMENT STANDARDS FOR EXISTING SOURCES

PSES
 Precious Metals Forming
 Surface Treatment Rinse

Pollutant or pollutant property	Maximum for any one day	Maximum for monthly average
mg/off-kg (lb/million off-lbs) of precious metals surface treated		
*Cadmium	.210	.092
Chromium	.271	.111
*Copper	1.170	.616
*Cyanide	.179	.074
*Lead	.259	.123
Nickel	1.180	.783
*Silver	.253	.105
Zinc	.900	.376

PSES
 Precious Metals Forming
 Alkaline Cleaning Spent Baths

Pollutant or pollutant property	Maximum for any one day	Maximum for monthly average
mg/off-kg (lb/million off-lbs) of precious metals alkaline cleaned		
*Cadmium	.020	.009
Chromium	.026	.011
*Copper	.114	.060
*Cyanide	.017	.007
*Lead	.025	.012
Nickel	.115	.076
*Silver	.025	.010
Zinc	.088	.037

Table XII-16 (Continued)

PRECIOUS METALS FORMING SUBCATEGORY
 PRETREATMENT STANDARDS FOR EXISTING SOURCES

PSES
 Precious Metals Forming
 Alkaline Cleaning Rinse

Pollutant or pollutant property	Maximum for any one day	Maximum for monthly average
mg/off-kg (lb/million off-lbs) of precious metals alkaline cleaned		
*Cadmium	.381	.168
Chromium	.493	.202
*Copper	2.130	1.120
*Cyanide	.325	.135
*Lead	.471	.224
Nickel	2.150	1.420
*Silver	.459	.191
Zinc	1.640	.683

PSES
 Precious Metals Forming
 Alkaline Cleaning Prebonding Wastewater

Pollutant or pollutant property	Maximum for any one day	Maximum for monthly average
mg/off-kg (lb/million off-lbs) of precious metals and base metal cleaned prior to bonding		
*Cadmium	.395	.174
Chromium	.511	.209
*Copper	2.210	1.160
*Cyanide	.337	.139
*Lead	.487	.232
Nickel	2.230	1.480
*Silver	.476	.197
Zinc	1.700	.708

Table XII-16 (Continued)

PRECIOUS METALS FORMING SUBCATEGORY
 PRETREATMENT STANDARDS FOR EXISTING SOURCES

PSES
 Precious Metals Forming
 Tumbling or Burnishing Wastewater

Pollutant or pollutant property	Maximum for any one day	Maximum for monthly average
mg/off-kg (lb/million off-lbs) of precious metals tumbled or burnished		
*Cadmium	.412	.182
Chromium	.533	.218
*Copper	2.300	1.210
*Cyanide	.351	.145
*Lead	.508	.242
Nickel	2.330	1.540
*Silver	.496	.206
Zinc	1.770	.738

PSES
 Precious Metals Forming
 Sawing or Grinding Spent Neat Oils

There shall be no discharge of process wastewater
 pollutants.

PSES
 Precious Metals Forming
 Sawing or Grinding Spent Emulsions

Pollutant or pollutant property	Maximum for any one day	Maximum for monthly average
mg/off-kg (lb/million off-lbs) of precious metals sawed or ground with emulsions		
*Cadmium	.032	.014
Chromium	.041	.017
*Copper	.178	.093
*Cyanide	.027	.011
*Lead	.039	.019
Nickel	.180	.119
*Silver	.038	.016
Zinc	.137	.057

Table XII-16 (Continued)

PRECIOUS METALS FORMING SUBCATEGORY
 PRETREATMENT STANDARDS FOR EXISTING SOURCES

PSES

Precious Metals Forming
 Pressure Bonding Contact Cooling Water

Pollutant or pollutant property	Maximum for any one day	Maximum for monthly average
mg/off-kg (lb/million off-lbs) of precious metals and base metal pressure bonded		
*Cadmium	.028	.013
Chromium	.037	.015
*Copper	.159	.084
*Cyanide	.024	.010
*Lead	.035	.017
Nickel	.161	.106
*Silver	.034	.014
Zinc	.122	.051

PSES

Precious Metals Forming
 Degreasing Spent Solvents

There shall be no discharge of process wastewater
 pollutants.

PSES

Precious Metals Forming
 Wet Air Pollution Control Blowdown

There shall be no discharge of process wastewater
 pollutants.

Table XII-17

REFRACTORY METALS FORMING SUBCATEGORY
 PRETREATMENT STANDARDS FOR EXISTING SOURCES

PSES

Refractory Metals Forming
 Rolling Spent Neat Oils and Graphite-Based Lubricants

There shall be no discharge of process wastewater
 pollutants.

PSES

Refractory Metals Forming
 Rolling Spent Emulsions

Pollutant or pollutant property	Maximum for any one day	Maximum for monthly average
mg/off-kg (lb/million off-lbs) of refractory metals rolled with emulsions		
Chromium	.189	.077
*Copper	.815	.429
Lead	.180	.086
*Nickel	.824	.545
Silver	.176	.073
Zinc	.627	.262
Columbium	.052	---
*Fluoride	25.500	11.300
*Molybdenum	2.840	1.470
Tantalum	.193	---
Vanadium	.043	---
Tungsten	2.990	1.190

PSES

Refractory Metals Forming
 Drawing Spent Lubricants

There shall be no discharge of process wastewater
 pollutants.

Table XII-17 (Continued)

REFRACTORY METALS FORMING SUBCATEGORY
 PRETREATMENT STANDARDS FOR EXISTING SOURCES

PSES
 Refractory Metals Forming
 Extrusion Spent Lubricants

There shall be no discharge of process wastewater pollutants.

PSES
 Refractory Metals Forming
 Extrusion Press Hydraulic Fluid Leakage

Pollutant or pollutant property	Maximum for any one day	Maximum for monthly average
mg/off-kg (lb/million off-lbs) of refractory metals extruded		
Chromium	.524	.214
*Copper	2.260	1.190
Lead	.500	.238
*Nickel	2.290	1.510
Silver	.488	.203
Zinc	1.740	.726
Columbium	.143	---
*Fluoride	70.800	31.400
*Molybdenum	7.870	4.070
Tantalum	.536	---
Vanadium	.119	---
Tungsten	8.280	3.310

PSES
 Refractory Metals Forming
 Forging Spent Lubricants

There shall be no discharge of process wastewater pollutants.

Table XII-17 (Continued)

REFRACTORY METALS FORMING SUBCATEGORY
PRETREATMENT STANDARDS FOR EXISTING SOURCES

PSES

Refractory Metals Forming
Forging Contact Cooling Water

Pollutant or pollutant property	Maximum for any one day	Maximum for monthly average
mg/off-kg (lb/million off-lbs) of forged refractory metals cooled with water		
Chromium	.014	.006
*Copper	.061	.032
Lead	.014	.006
*Nickel	.062	.041
Silver	.013	.005
Zinc	.047	.020
Columbium	.004	---
*Fluoride	1.920	.853
*Molybdenum	.214	.111
Tantalum	.015	---
Vanadium	.003	---
Tungsten	.225	.090

PSES

Refractory Metals Forming
Metal Powder Production Wastewater

Pollutant or pollutant property	Maximum for any one day	Maximum for monthly average
mg/off-kg (lb/million off-lbs) of refractory metals powder produced		
Chromium	.124	.051
*Copper	.534	.281
Lead	.118	.056
*Nickel	.540	.357
Silver	.115	.048
Zinc	.410	.172
Columbium	.034	---
*Fluoride	16.700	7.420
*Molybdenum	1.860	.961
Tantalum	.127	---
Vanadium	.028	---
Tungsten	1.960	.781

Table XII-17 (Continued)

REFRACTORY METALS FORMING SUBCATEGORY
 PRETREATMENT STANDARDS FOR EXISTING SOURCES

PSES

Refractory Metals Forming
 Metal Powder Production Floor Wash Water

There shall be no discharge of process wastewater pollutants.

PSES

Refractory Metals Forming
 Metal Powder Pressing Spent Lubricants

There shall be no discharge of process wastewater pollutants.

PSES

Refractory Metals Forming
 Surface Treatment Spent Baths

Pollutant or pollutant property	Maximum for any one day	Maximum for monthly average
mg/off-kg (lb/million off-lbs) of refractory metals surface treated		
Chromium	.171	.070
*Copper	.739	.389
Lead	.164	.078
*Nickel	.747	.494
Silver	.160	.066
Zinc	.568	.237
Columbium	.047	---
*Fluoride	23.200	10.300
*Molybdenum	2.570	1.330
Tantalum	.175	---
Vanadium	.039	---
Tungsten	2.710	1.080

Table XII-17 (Continued)

REFRACTORY METALS FORMING SUBCATEGORY
PRETREATMENT STANDARDS FOR EXISTING SOURCESPFS
Refractory Metals Forming
Surface Treatment Rinse

Pollutant or pollutant property	Maximum for any one day	Maximum for monthly average
mg/off-kg (lb/million off-lbs) of refractory metals surface treated		
Chromium	5.330	2.180
*Copper	23.000	12.100
Lead	5.080	2.420
*Nickel	23.300	15.400
Silver	4.960	2.060
Zinc	17.700	7.380
Columbium	1.450	---
*Fluoride	720.000	320.000
*Molybdenum	80.000	41.400
Tantalum	5.450	---
Vanadium	1.210	---
Tungsten	84.200	33.700

PSES
Refractory Metals Forming
Alkaline Cleaning Spent Baths

Pollutant or pollutant property	Maximum for any one day	Maximum for monthly average
mg/off-kg (lb/million off-lbs) of refractory metals alkaline cleaned		
Chromium	.147	.060
*Copper	.635	.334
Lead	.140	.067
*Nickel	.641	.424
Silver	.137	.057
Zinc	.488	.204
Columbium	.040	---
*Fluoride	19.900	8.820
*Molybdenum	2.210	1.140
Tantalum	.151	---
Vanadium	.033	---
Tungsten	2.330	.929

Table XII-17 (Continued)

REFRACTORY METALS FORMING SUBCATEGORY
PRETREATMENT STANDARDS FOR EXISTING SOURCES

PSES

Refractory Metals Forming
Alkaline Cleaning Rinse

Pollutant or pollutant property	Maximum for any one day	Maximum for monthly average
mg/off-kg (lb/million off-lbs) of refractory metals alkaline cleaned		
Chromium	3.590	1.470
*Copper	15.500	8.160
Lead	3.430	1.630
*Nickel	15.700	10.400
Silver	3.350	1.390
Zinc	11.900	4.980
Columbium	.979	---
*Fluoride	486.000	216.000
*Molybdenum	54.000	27.900
Tantalum	3.670	---
Vanadium	.816	---
Tungsten	56.800	22.700

PSES

Refractory Metals Forming
Molten Salt Rinse

Pollutant or pollutant property	Maximum for any one day	Maximum for monthly average
mg/off-kg (lb/million off-lbs) of refractory metals treated with molten salt		
Chromium	.279	.114
*Copper	1.200	.633
Lead	.266	.127
*Nickel	1.220	.804
Silver	.260	.108
Zinc	.924	.386
Columbium	.076	---
*Fluoride	37.700	16.700
*Molybdenum	4.190	2.170
Tantalum	.285	---
Vanadium	.063	---
Tungsten	4.410	1.760

Table XII-17 (Continued)

REFRACTORY METALS FORMING SUBCATEGORY
PRETREATMENT STANDARDS FOR EXISTING SOURCES

PSES
Refractory Metals Forming
Tumbling or Burnishing Wastewater

Pollutant or pollutant property	Maximum for any one day	Maximum for monthly average
mg/off-kg (lb/million off-lbs) of refractory metals tumbled or burnished		
Chromium	.550	.225
*Copper	2.380	1.250
Lead	.525	.250
*Nickel	2.400	1.590
Silver	.513	.213
Zinc	1.830	.763
Columbium	.150	---
*Fluoride	74.400	33.000
*Molybdenum	8.260	4.280
Tantalum	.563	---
Vanadium	.125	---
Tungsten	8.700	3.480

PSES
Refractory Metals Forming
Sawing or Grinding Spent Neat Oils

There shall be no discharge of process wastewater
pollutants.

Table XII-17 (Continued)

REFRACTORY METALS FORMING SUBCATEGORY
PRETREATMENT STANDARDS FOR EXISTING SOURCESPSES
Refractory Metals Forming
Sawing or Grinding Spent Emulsions

Pollutant or pollutant property	Maximum for any one day	Maximum for monthly average
mg/off-kg (lb/million off-lbs) of refractory metals sawed or ground with emulsions		
Chromium	.131	.054
*Copper	.565	.297
Lead	.125	.059
*Nickel	.570	.377
Silver	.122	.051
Zinc	.434	.181
Columbium	.036	---
*Fluoride	17.700	7.840
*Molybdenum	1.970	1.020
Tantalum	.134	---
Vanadium	.030	---
Tungsten	2.070	.826

PSES
Refractory Metals Forming
Sawing or Grinding Contact Cooling Water

Pollutant or pollutant property	Maximum for any one day	Maximum for monthly average
mg/off-kg (lb/million off-lbs) of refractory metals sawed or ground with contact cooling water		
Chromium	1.070	.438
*Copper	4.620	2.430
Lead	1.020	.486
*Nickel	4.670	3.090
Silver	.997	.413
Zinc	3.550	1.480
Columbium	.292	---
*Fluoride	145.000	64.200
*Molybdenum	16.100	8.310
Tantalum	1.100	---
Vanadium	.243	---
Tungsten	16.900	6.760

Table XII-17 (Continued)

REFRACTORY METALS FORMING SUBCATEGORY
PRETREATMENT STANDARDS FOR EXISTING SOURCES

PSES

Refractory Metals Forming
Sawing or Grinding Rinse

Pollutant or pollutant property	Maximum for any one day	Maximum for monthly average
mg/off-kg (lb/million off-lbs) of sawed or ground refractory metals rinsed		
Chromium	.006	.002
*Copper	.026	.014
Lead	.006	.003
*Nickel	.026	.017
Silver	.006	.002
Zinc	.020	.008
Columbium	.002	---
*Fluoride	.803	.357
*Molybdenum	.089	.046
Tantalum	.006	---
Vanadium	.001	---
Tungsten	.094	.038

PSES

Refractory Metals Forming
Dye Penetrant Testing Wastewater

Pollutant or pollutant property	Maximum for any one day	Maximum for monthly average
mg/off-kg (lb/million off-lbs) of refractory metals tested with dye penetrant methods		
Chromium	.034	.014
*Copper	.148	.078
Lead	.033	.016
*Nickel	.149	.099
Silver	.032	.013
Zinc	.113	.047
Columbium	.009	---
*Fluoride	4.620	2.050
*Molybdenum	.513	.266
Tantalum	.035	---
Vanadium	.008	---
Tungsten	.540	.216

Table XII-17 (Continued)

REFRACTORY METALS FORMING SUBCATEGORY
PRETREATMENT STANDARDS FOR EXISTING SOURCESPSES
Refractory Metals Forming
Equipment Cleaning Wastewater

Pollutant or pollutant property	Maximum for any one day	Maximum for monthly average
mg/off-kg (lb/million off-lbs) of refractory metals formed		
Chromium	.060	.025
*Copper	.259	.136
Lead	.057	.027
*Nickel	.261	.173
Silver	.056	.023
Zinc	.199	.083
Columbium	.016	---
*Fluoride	8.090	3.590
*Molybdenum	.899	.465
Tantalum	.061	---
Vanadium	.014	---
Tungsten	.947	.378

PSES
Refractory Metals Forming
Miscellaneous Wastewater Sources

Pollutant or pollutant property	Maximum for any one day	Maximum for monthly average
mg/off-kg (lb/million off-lbs) of refractory metals formed		
Chromium	.152	.062
*Copper	.656	.345
Lead	.145	.069
*Nickel	.663	.438
Silver	.142	.059
Zinc	.504	.211
Columbium	.041	---
*Fluoride	20.500	9.110
*Molybdenum	2.280	1.180
Tantalum	.155	---
Vanadium	.035	---
Tungsten	2.400	.959

Table XII-17 (Continued)

REFRACTORY METALS FORMING SUBCATEGORY
PRETREATMENT STANDARDS FOR EXISTING SOURCES

PSES
Refractory Metals Forming
Degreasing Spent Solvents

There shall be no discharge of process wastewater pollutants.

PSES
Refractory Metals Forming
Wet Air Pollution Control Blowdown

Pollutant or pollutant property	Maximum for any one day	Maximum for monthly average
mg/off-kg (lb/million off-lbs) of refractory metals formed		
Chromium	.346	.142
*Copper	1.500	.787
Lead	.331	.158
*Nickel	1.510	1.000
Silver	.323	.134
Zinc	1.150	.480
Columbium	.095	---
*Fluoride	46.800	20.800
*Molybdenum	5.200	2.690
Tantalum	.354	---
Vanadium	.079	---
Tungsten	5.480	2.190

Table XII-18

TITANIUM FORMING SUBCATEGORY
 PRETREATMENT STANDARDS FOR EXISTING SOURCES

PSES

Titanium Forming
 Rolling Spent Neat Oils

There shall be no discharge of process wastewater pollutants.

PSES

Titanium Forming
 Rolling Contact Cooling Water

Pollutant or pollutant property	Maximum for any one day	Maximum for monthly average
mg/off-kg (lb/million off-lbs) of titanium rolled with contact cooling water		
Chromium	.215	.088
Copper	.927	.488
*Cyanide	.142	.059
*Lead	.205	.098
Nickel	.937	.620
*Zinc	.713	.298
*Ammonia	65.100	28.600
*Fluoride	29.100	12.900
Titanium	.459	.200

PSES

Titanium Forming
 Drawing Spent Neat Oils

There shall be no discharge of process wastewater pollutants.

PSES

Titanium Forming
 Extrusion Spent Neat Oils

There shall be no discharge of process wastewater pollutants.

Table XII-18 (Continued)

TITANIUM FORMING SUBCATEGORY
 PRETREATMENT STANDARDS FOR EXISTING SOURCES

PSES
 Titanium Forming
 Extrusion Spent Emulsions

Pollutant or pollutant property	Maximum for any one day	Maximum for monthly average
mg/off-kg (lb/million off-lbs) of titanium extruded with emulsions		
Chromium	.032	.013
Copper	.137	.072
*Cyanide	.021	.009
*Lead	.030	.014
Nickel	.138	.091
*Zinc	.105	.044
*Ammonia	9.590	4.220
*Fluoride	4.280	1.900
Titanium	.068	.030

PSES
 Titanium Forming
 Extrusion Press Hydraulic Fluid Leakage

Pollutant or pollutant property	Maximum for any one day	Maximum for monthly average
mg/off-kg (lb/million off-lbs) of titanium extruded		
Chromium	.078	.032
Copper	.338	.178
*Cyanide	.052	.021
*Lead	.075	.036
Nickel	.342	.226
*Zinc	.260	.109
*Ammonia	23.700	10.500
*Fluoride	10.600	4.700
Titanium	.168	.073

Table XII-18 (Continued)

TITANIUM FORMING SUBCATEGORY
 PRETREATMENT STANDARDS FOR EXISTING SOURCES

PSES

Titanium Forming
 Forging Spent Lubricants

There shall be no discharge of process wastewater pollutants.

PSES

Titanium Forming
 Forging Contact Cooling Water

Pollutant or pollutant property	Maximum for any one day	Maximum for monthly average
mg/off-kg (lb/million off-lbs) of forged titanium cooled with water		
Chromium	.044	.018
Copper	.190	.100
*Cyanide	.029	.012
*Lead	.042	.020
Nickel	.192	.127
*Zinc	.146	.061
*Ammonia	13.300	5.860
*Fluoride	5.950	2.640
Titanium	.094	.041

PSES

Titanium Forming
 Forging Equipment Cleaning Wastewater

Pollutant or pollutant property	Maximum for any one day	Maximum for monthly average
mg/off-kg (lb/million off-lbs) of titanium forged		
Chromium	.018	.007
Copper	.076	.040
*Cyanide	.012	.005
*Lead	.017	.008
Nickel	.077	.051
*Zinc	.058	.024
*Ammonia	5.330	2.350
*Fluoride	2.380	1.060
Titanium	.038	.016

Table XII-18 (Continued)

TITANIUM FORMING SUBCATEGORY
 PRETREATMENT STANDARDS FOR EXISTING SOURCES

PSES
 Titanium Forming
 Forging Press Hydraulic Fluid Leakage

Pollutant or pollutant property	Maximum for any one day	Maximum for monthly average
mg/off-kg (lb/million off-lbs) of titanium forged		
Chromium	.445	.182
Copper	1.920	1.010
*Cyanide	.293	.121
*Lead	.424	.202
Nickel	1.940	1.280
*Zinc	1.480	.616
*Ammonia	135.000	59.200
*Fluoride	60.100	26.700
Titanium	.950	.414

PSES
 Titanium Forming
 Tube Reducing Spent Lubricants

There shall be no discharge of process wastewater
 pollutants.

PSES
 Titanium Forming
 Heat Treatment Contact Cooling Water

There shall be no allowance for the discharge of
 process wastewater pollutants.

Table XII-18 (Continued)

TITANIUM FORMING SUBCATEGORY
 PRETREATMENT STANDARDS FOR EXISTING SOURCES

PSES

Titanium Forming
 Surface Treatment Spent Baths

Pollutant or pollutant property	Maximum for any one day	Maximum for monthly average
mg/off-kg (lb/million off-lbs) of titanium surface treated		
Chromium	.092	.038
Copper	.395	.208
*Cyanide	.060	.025
*Lead	.087	.042
Nickel	.400	.264
*Zinc	.304	.127
*Ammonia	27.700	12.200
*Fluoride	12.400	5.490
Titanium	.196	.085

PSES

Titanium Forming
 Surface Treatment Rinse

Pollutant or pollutant property	Maximum for any one day	Maximum for monthly average
mg/off-kg (lb/million off-lbs) of titanium surface treated		
Chromium	1.290	.526
Copper	5.550	2.920
*Cyanide	.847	.351
*Lead	1.230	.584
Nickel	5.610	3.710
*Zinc	4.270	1.780
*Ammonia	389.000	171.000
*Fluoride	174.000	77.100
Titanium	2.750	1.200

Table XII-18 (Continued)

TITANIUM FORMING SUBCATEGORY
PRETREATMENT STANDARDS FOR EXISTING SOURCES

PSES
Titanium Forming
Alkaline Cleaning Spent Baths

Pollutant or pollutant property	Maximum for any one day	Maximum for monthly average
mg/off-kg (lb/million off-lbs) of titanium alkaline cleaned		
Chromium	.106	.043
Copper	.456	.240
*Cyanide	.070	.029
*Lead	.101	.048
Nickel	.461	.305
*Zinc	.351	.147
*Ammonia	32.000	14.100
*Fluoride	14.300	6.340
Titanium	.226	.098

PSES
Titanium Forming
Alkaline Cleaning Rinse

Pollutant or pollutant property	Maximum for any one day	Maximum for monthly average
mg/off-kg (lb/million off-lbs) of titanium alkaline cleaned		
Chromium	.122	.050
Copper	.525	.276
*Cyanide	.080	.033
*Lead	.116	.055
Nickel	.530	.351
*Zinc	.403	.169
*Ammonia	36.800	16.200
*Fluoride	16.400	7.290
Titanium	.260	.113

Table XII-18 (Continued)

TITANIUM FORMING SUBCATEGORY
 PRETREATMENT STANDARDS FOR EXISTING SOURCES

PSES
 Titanium Forming
 Molten Salt Rinse

Pollutant or pollutant property	Maximum for any one day	Maximum for monthly average
mg/off-kg (lb/million off-lbs) of titanium treated with molten salt		
Chromium	.420	.172
Copper	1.820	.955
*Cyanide	.277	.115
*Lead	.401	.191
Nickel	1.840	1.210
*Zinc	1.400	.583
*Ammonia	128.000	56.000
*Fluoride	56.800	25.200
Titanium	.898	.392

PSES
 Titanium Forming
 Tumbling Wastewater

Pollutant or pollutant property	Maximum for any one day	Maximum for monthly average
mg/off-kg (lb/million off-lbs) of titanium tumbled		
Chromium	.035	.014
Copper	.150	.079
*Cyanide	.023	.009
*Lead	.033	.016
Nickel	.152	.101
*Zinc	.116	.048
*Ammonia	10.600	4.630
*Fluoride	4.700	2.090
Titanium	.074	.032

Table XII-18 (Continued)

TITANIUM FORMING SUBCATEGORY
 PRETREATMENT STANDARDS FOR EXISTING SOURCES

PSES

Titanium Forming
 Sawing or Grinding Spent Neat Oils

There shall be no discharge of process wastewater
 pollutants.

PSES

Titanium Forming
 Sawing or Grinding Spent Emulsions

Pollutant or pollutant property	Maximum for any one day	Maximum for monthly average
mg/off-kg (lb/million off-lbs) of titanium sawed or ground with emulsions		
Chromium	.081	.033
Copper	.348	.183
*Cyanide	.053	.022
*Lead	.077	.037
Nickel	.352	.233
*Zinc	.267	.112
*Ammonia	24.400	10.700
*Fluoride	10.900	4.830
Titanium	.172	.075

PSES

Titanium Forming
 Sawing or Grinding Contact Cooling Water

Pollutant or pollutant property	Maximum for any one day	Maximum for monthly average
mg/off-kg (lb/million off-lbs) of titanium sawed or ground with contact cooling water		
Chromium	.210	.086
Copper	.905	.476
*Cyanide	.138	.057
*Lead	.200	.095
Nickel	.914	.605
*Zinc	.695	.291
*Ammonia	63.500	27.900
*Fluoride	28.300	12.600
Titanium	.448	.195

Table XII-18 (Continued)

TITANIUM FORMING SUBCATEGORY
 PRETREATMENT STANDARDS FOR EXISTING SOURCES

PSES

Titanium Forming

Dye Penetrant Testing Wastewater

Pollutant or pollutant property	Maximum for any one day	Maximum for monthly average
mg/off-kg (lb/million off-lbs) of titanium tested with dye penetrant methods		
Chromium	.493	.202
Copper	2.130	1.120
*Cyanide	.325	.135
*Lead	.471	.224
Nickel	2.150	1.420
*Zinc	1.640	.683
*Ammonia	149.000	65.700
*Fluoride	66.700	29.600
Titanium	1.050	.459

PSES

Titanium Forming

Miscellaneous Wastewater Sources

Pollutant or pollutant property	Maximum for any one day	Maximum for monthly average
mg/off-kg (lb/million off-lbs) of titanium formed		
Chromium	.014	.006
Copper	.062	.032
*Cyanide	.009	.004
*Lead	.014	.006
Nickel	.062	.041
*Zinc	.047	.020
*Ammonia	4.320	1.900
*Fluoride	1.930	.856
Titanium	.031	.013

Table XII-18 (Continued)

TITANIUM FORMING SUBCATEGORY
 PRETREATMENT STANDARDS FOR EXISTING SOURCES

PSES
 Titanium Forming
 Degreasing Spent Solvents

There shall be no discharge of process wastewater pollutants.

PSES
 Titanium Forming
 Wet Air Pollution Control Blowdown

Pollutant or pollutant property	Maximum for any one day	Maximum for monthly average
mg/off-kg (lb/million off-lbs) of titanium formed		
Chromium	.094	.039
Copper	.407	.214
*Cyanide	.062	.026
*Lead	.090	.043
Nickel	.411	.272
*Zinc	.313	.131
*Ammonia	28.500	12.600
*Fluoride	12.800	5.650
Titanium	.201	.088

Table XII-19

URANIUM FORMING SUBCATEGORY
 PRETREATMENT STANDARDS FOR EXISTING SOURCES

PSES
 Uranium Forming
 Extrusion Tool Contact Cooling Water

Pollutant or pollutant property	Maximum for any one day	Maximum for monthly average
mg/off-kg (lb/million off-lbs) of uranium extruded		
*Cadmium	.007	.003
*Chromium	.013	.005
*Copper	.044	.021
*Lead	.010	.004
*Nickel	.019	.013
Zinc	.035	.015
*Fluoride	2.050	.908
*Molybdenum	.173	.077
Uranium	.148	.108

PSES
 Uranium Forming
 Heat Treatment Contact Cooling Water

Pollutant or pollutant property	Maximum for any one day	Maximum for monthly average
mg/off-kg (lb/million off-lbs) of extruded or forged uranium heat treated		
*Cadmium	.006	.003
*Chromium	.012	.005
*Copper	.040	.019
*Lead	.009	.004
*Nickel	.017	.012
Zinc	.032	.013
*Fluoride	1.860	.827
*Molybdenum	.158	.070
Uranium	.134	.098

Table XII-19 (Continued)

URANIUM FORMING SUBCATEGORY
 PRETREATMENT STANDARDS FOR EXISTING SOURCES

PSES
 Uranium Forming
 Surface Treatment Spent Baths

Pollutant or pollutant property	Maximum for any one day	Maximum for monthly average
mg/off-kg (lb/million off-lbs) of uranium surface treated		
*Cadmium	.005	.002
*Chromium	.010	.004
*Copper	.035	.017
*Lead	.008	.004
*Nickel	.015	.010
Zinc	.028	.011
*Fluoride	1.620	.718
*Molybdenum	.137	.061
Uranium	.117	.085

PSES
 Uranium Forming
 Surface Treatment Rinse

Pollutant or pollutant property	Maximum for any one day	Maximum for monthly average
mg/off-kg (lb/million off-lbs) of uranium surface treated		
*Cadmium	.067	.027
*Chromium	.125	.051
*Copper	.432	.206
*Lead	.094	.044
*Nickel	.186	.125
Zinc	.344	.142
*Fluoride	20.100	8.900
*Molybdenum	1.700	.752
Uranium	1.450	1.050

Table XII-19 (Continued)

URANIUM FORMING SUBCATEGORY
PRETREATMENT STANDARDS FOR EXISTING SOURCES

PSES

Uranium Forming
Sawing or Grinding Spent Emulsions

Pollutant or pollutant property	Maximum for any one day	Maximum for monthly average
------------------------------------	----------------------------	--------------------------------

mg/off-kg (lb/million off-lbs) of uranium
sawed or ground with emulsions

*Cadmium	.0011	.0005
*Chromium	.0021	.0009
*Copper	.0073	.0035
*Lead	.0016	.0007
*Nickel	.0031	.0021
Zinc	.0058	.0024
*Fluoride	.3380	.1500
*Molybdenum	.0286	.0127
Uranium	.0244	.0178

PSES

Uranium Forming
Sawing or Grinding Contact Cooling Water

Pollutant or pollutant property	Maximum for any one day	Maximum for monthly average
------------------------------------	----------------------------	--------------------------------

mg/off-kg (lb/million off-lbs) of uranium
sawed or ground with contact cooling water

*Cadmium	.033	.013
*Chromium	.061	.025
*Copper	.211	.101
*Lead	.046	.022
*Nickel	.091	.061
Zinc	.169	.069
*Fluoride	9.820	4.360
*Molybdenum	.830	.368
Uranium	.708	.515

Table XII-19 (Continued)

URANIUM FORMING SUBCATEGORY
 PRETREATMENT STANDARDS FOR EXISTING SOURCES

PSES

Uranium Forming
 Sawing or Grinding Rinse

Pollutant or pollutant property	Maximum for any one day	Maximum for monthly average
mg/off-kg (lb/million off-lbs) of sawed or ground uranium rinsed		
*Cadmium	.0009	.0004
*Chromium	.0017	.0007
*Copper	.0060	.0028
*Lead	.0013	.0006
*Nickel	.0026	.0017
Zinc	.0048	.0020
*Fluoride	.2770	.1230
*Molybdenum	.0234	.0104
Uranium	.0200	.0145

PSES

Uranium Forming
 Area Cleaning Washwater

Pollutant or pollutant property	Maximum for any one day	Maximum for monthly average
mg/off-kg (lb/million off-lbs) of uranium formed		
*Cadmium	.009	.003
*Chromium	.016	.006
*Copper	.055	.026
*Lead	.012	.006
*Nickel	.024	.016
Zinc	.044	.018
*Fluoride	2.550	1.130
*Molybdenum	.216	.096
Uranium	.184	.134

Table XII-19 (Continued)

URANIUM FORMING SUBCATEGORY
 PRETREATMENT STANDARDS FOR EXISTING SOURCES

PSES
 Uranium Forming
 Wet Air Pollution Control Blowdown

Pollutant or pollutant property	Maximum for any one day	Maximum for monthly average
mg/off-kg (lb/million off-lbs) of uranium surface treated		
*Cadmium	.0007	.0003
*Chromium	.0013	.0005
*Copper	.0045	.0021
*Lead	.0010	.0005
*Nickel	.0019	.0013
Zinc	.0036	.0015
*Fluoride	.2080	.0922
*Molybdenum	.0176	.0078
Uranium	.0150	.0109

PSES
 Uranium Forming
 Drum Washwater

Pollutant or pollutant property	Maximum for any one day	Maximum for monthly average
mg/off-kg (lb/million off-lbs) of uranium formed		
*Cadmium	.009	.004
*Chromium	.016	.007
*Copper	.057	.027
*Lead	.012	.006
*Nickel	.024	.016
Zinc	.045	.019
*Fluoride	2.640	1.170
*Molybdenum	.223	.099
Uranium	.190	.138

Table XII-19 (Continued)

URANIUM FORMING SUBCATEGORY
 PRETREATMENT STANDARDS FOR EXISTING SOURCES

PSES
 Uranium Forming
 Laundry Washwater

Pollutant or pollutant property	Maximum for any one day	Maximum for monthly average
<hr/> mg/employee-day uranium formed <hr/>		
Cadmium	.005	.002
*Cadmium	.010	.004
*Chromium	.034	.016
*Copper	.007	.003
*Lead	.014	.010
*Nickel	.027	.011
Zinc	1.560	.692
*Fluoride	.132	.058
*Molybdenum	.113	.082
Uranium	.190	.138

Table XII-20

ZINC FORMING SUBCATEGORY
 PRETREATMENT STANDARDS FOR EXISTING SOURCES

PSES
 Zinc Forming
 Rolling Spent Emulsions

Pollutant or pollutant property	Maximum for any one day	Maximum for monthly average
mg/off-kg (lb/million off-lbs) of zinc rolled with emulsions		
*Chromium	.0005	.0002
*Copper	.0018	.0009
*Cyanide	.0003	.0001
Nickel	.0008	.0005
*Zinc	.0014	.0006

PSES
 Zinc Forming
 Rolling Contact Cooling Water

Pollutant or pollutant property	Maximum for any one day	Maximum for monthly average
mg/off-kg (lb/million off-lbs) of zinc rolled with contact cooling water		
*Chromium	.020	.008
*Copper	.069	.033
*Cyanide	.011	.004
Nickel	.030	.020
*Zinc	.055	.023

Table XII-20 (Continued)

ZINC FORMING SUBCATEGORY
 PRETREATMENT STANDARDS FOR EXISTING SOURCES

PSES
 Zinc Forming
 Drawing Spent Emulsions

Pollutant or pollutant property	Maximum for any one day	Maximum for monthly average
mg/off-kg (lb/million off-lbs) of zinc drawn with emulsions		
*Chromium	.0022	.0009
*Copper	.0074	.0035
*Cyanide	.0012	.0005
Nickel	.0032	.0022
*Zinc	.0059	.0024

PSES
 Zinc Forming
 Direct Chill Casting Contact Cooling Water

Pollutant or pollutant property	Maximum for any one day	Maximum for monthly average
mg/off-kg (lb/million off-lbs) of zinc cast by the direct chill method		
*Chromium	.019	.008
*Copper	.065	.031
*Cyanide	.010	.004
Nickel	.028	.019
*Zinc	.052	.021

Table XII-20 (Continued)

ZINC FORMING SUBCATEGORY
 PRETREATMENT STANDARDS FOR EXISTING SOURCES

PSES
 Zinc Forming
 Heat Treatment Contact Cooling Water

Pollutant or pollutant property	Maximum for any one day	Maximum for monthly average
mg/off-kg (lb/million off-lbs) of zinc heat treated		
*Chromium	.028	.012
*Copper	.098	.047
*Cyanide	.015	.006
Nickel	.042	.028
*Zinc	.078	.032

PSES
 Zinc Forming
 Surface Treatment Spent Baths

Pollutant or pollutant property	Maximum for any one day	Maximum for monthly average
mg/off-kg (lb/million off-lbs) of zinc surface treated		
*Chromium	.033	.013
*Copper	.114	.054
*Cyanide	.018	.007
Nickel	.049	.033
*Zinc	.091	.037

Table XII-20 (Continued)

ZINC FORMING SUBCATEGORY
 PRETREATMENT STANDARDS FOR EXISTING SOURCES

PSES
 Zinc Forming
 Surface Treatment Rinse

Pollutant or pollutant property	Maximum for any one day	Maximum for monthly average
mg/off-kg (lb/million off-lbs) of zinc surface treated		
*Chromium	.133	.054
*Copper	.458	.219
*Cyanide	.072	.029
Nickel	.197	.133
*Zinc	.365	.151

PSES
 Zinc Forming
 Alkaline Cleaning Spent Baths

Pollutant or pollutant property	Maximum for any one day	Maximum for monthly average
mg/off-kg (lb/million off-lbs) of zinc alkaline cleaned		
*Chromium	.0013	.0005
*Copper	.0046	.0022
*Cyanide	.0007	.0003
Nickel	.0020	.0013
*Zinc	.0036	.0015

Table XII-20 (Continued)

ZINC FORMING SUBCATEGORY
 PRETREATMENT STANDARDS FOR EXISTING SOURCES

PSES
 Zinc Forming
 Alkaline Cleaning Rinse

Pollutant or pollutant property	Maximum for any one day	Maximum for monthly average
mg/off-kg (lb/million off-lbs) of zinc alkaline cleaned		
*Chromium	.626	.254
*Copper	2.170	1.030
*Cyanide	.338	.135
Nickel	.930	.626
*Zinc	1.730	.710

PSES
 Zinc Forming
 Sawing or Grinding Spent Emulsions

Pollutant or pollutant property	Maximum for any one day	Maximum for monthly average
mg/off-kg (lb/million off-lbs) of zinc sawed or ground with emulsions		
*Chromium	.009	.004
*Copper	.031	.015
*Cyanide	.005	.002
Nickel	.013	.009
*Zinc	.024	.010

Table XII-20 (Continued)

ZINC FORMING SUBCATEGORY
 PRETREATMENT STANDARDS FOR EXISTING SOURCES

PSES
 Zinc Forming
 Electrocoating Rinse

Pollutant or pollutant property	Maximum for any one day	Maximum for monthly average
mg/off-kg (lb/million off-lbs) of zinc electrocoated		
*Chromium	.085	.034
*Copper	.293	.140
*Cyanide	.046	.018
Nickel	.126	.085
*Zinc	.234	.096

Table XII-21

ZIRCONIUM-HAFNIUM FORMING SUBCATEGORY
 PRETREATMENT STANDARDS FOR EXISTING SOURCES

PSES

Zirconium-Hafnium Forming
 Rolling Spent Neat Oils

There shall be no discharge of process wastewater
 pollutants.

PSES

Zirconium-Hafnium Forming
 Drawing Spent Lubricants

There shall be no discharge of process wastewater
 pollutants.

PSES

Zirconium-Hafnium Forming
 Extrusion Spent Lubricants

There shall be no discharge of process wastewater
 pollutants.

PSES

Zirconium-Hafnium Forming
 Extrusion Press Hydraulic Fluid Leakage

Pollutant or pollutant property	Maximum for any one day	Maximum for monthly average
<hr/>		
mg/off-kg (lb/million off-lbs) of zirconium-hafnium extruded		
*Chromium	.104	.043
Copper	.451	.237
*Cyanide	.069	.029
Lead	.100	.047
*Nickel	.455	.301
Zinc	.346	.145
*Ammonia	31.600	13.900
*Fluoride	14.100	6.260
Zirconium	6.830	3.300

Table XII-21 (Continued)

ZIRCONIUM-HAFNIUM FORMING SUBCATEGORY
 PRETREATMENT STANDARDS FOR EXISTING SOURCES

PSES
 Zirconium-Hafnium Forming
 Swaging Spent Neat Oils

There shall be no discharge of process wastewater pollutants.

PSES
 Zirconium-Hafnium Forming
 Tube Reducing Spent Lubricants

There shall be no discharge of process wastewater pollutants.

PSES
 Zirconium-Hafnium Forming
 Heat Treatment Contact Cooling Water

Pollutant or pollutant property	Maximum for any one day	Maximum for monthly average
mg/off-kg (lb/million off-lbs) of zirconium-hafnium heat treated		
*Chromium	.015	.006
Copper	.065	.034
*Cyanide	.010	.004
Lead	.014	.007
*Nickel	.066	.044
Zinc	.050	.021
*Ammonia	4.570	2.010
*Fluoride	2.040	.906
Zirconium	.988	.477

Table XII-21 (Continued)

ZIRCONIUM-HAFNIUM FORMING SUBCATEGORY
 PRETREATMENT STANDARDS FOR EXISTING SOURCES

PSES

Zirconium-Hafnium Forming
 Surface Treatment Spent Baths

Pollutant or pollutant property	Maximum for any one day	Maximum for monthly average
mg/off-kg (lb/million off-lbs) of zirconium-hafnium surface treated		
*Chromium	.150	.061
Copper	.646	.340
*Cyanide	.099	.041
Lead	.143	.068
*Nickel	.653	.432
Zinc	.497	.208
*Ammonia	45.300	19.900
*Fluoride	20.300	8.980
Zirconium	9.790	4.730

PSES

Zirconium-Hafnium Forming
 Surface Treatment Rinse

Pollutant or pollutant property	Maximum for any one day	Maximum for monthly average
mg/off-kg (lb/million off-lbs) of zirconium-hafnium surface treated		
*Chromium	.391	.160
Copper	1.690	.888
*Cyanide	.258	.107
Lead	.373	.178
*Nickel	1.710	1.130
Zinc	1.300	.542
*Ammonia	119.000	52.100
*Fluoride	52.900	23.500
Zirconium	25.600	12.400

Table XII-21 (Continued)

ZIRCONIUM-HAFNIUM FORMING SUBCATEGORY
 PRETREATMENT STANDARDS FOR EXISTING SOURCES

PSES
 Zirconium-Hafnium Forming
 Alkaline Cleaning Spent Baths

Pollutant or pollutant property	Maximum for any one day	Maximum for monthly average
mg/off-kg (lb/million off-lbs) of zirconium-hafnium alkaline cleaned		
*Chromium	.704	.288
Copper	3.040	1.600
*Cyanide	.464	.192
Lead	.672	.320
*Nickel	3.070	2.030
Zinc	2.340	.976
*Ammonia	213.000	93.800
*Fluoride	95.200	42.300
Zirconium	46.100	22.300

PSES
 Zirconium-Hafnium Forming
 Alkaline Cleaning Rinse

Pollutant or pollutant property	Maximum for any one day	Maximum for monthly average
mg/off-kg (lb/million off-lbs) of zirconium-hafnium alkaline cleaned		
*Chromium	1.380	.565
Copper	5.970	3.140
*Cyanide	.911	.377
Lead	1.320	.628
*Nickel	6.030	3.990
Zinc	4.590	1.920
*Ammonia	419.000	184.000
*Fluoride	187.000	82.900
Zirconium	90.500	43.700

Table XII-21 (Continued)

ZIRCONIUM-HAFNIUM FORMING SUBCATEGORY
 PRETREATMENT STANDARDS FOR EXISTING SOURCES

PSES
 Zirconium-Hafnium Forming
 Molten Salt Rinse

Pollutant or pollutant property	Maximum for any one day	Maximum for monthly average
mg/off-kg (lb/million off-lbs) of zirconium-hafnium treated with molten salt		
*Chromium	.333	.136
Copper	1.440	.756
*Cyanide	.219	.091
Lead	.318	.151
*Nickel	1.450	.960
Zinc	1.110	.461
*Ammonia	101.000	44.300
*Fluoride	45.000	20.000
Zirconium	21.800	10.500

PSES
 Zirconium-Hafnium Forming
 Sawing or Grinding Spent Neat Oils

There shall be no discharge of process wastewater
 pollutants.

Table XII-21 (Continued)

ZIRCONIUM-HAFNIUM FORMING SUBCATEGORY
PRETREATMENT STANDARDS FOR EXISTING SOURCES

PSES

Zirconium-Hafnium Forming
Sawing or Grinding Spent Emulsions

Pollutant or pollutant property	Maximum for any one day	Maximum for monthly average
mg/off-kg (lb/million off-lbs) of zirconium-hafnium sawed or ground with emulsions		
*Chromium	.124	.051
Copper	.534	.281
*Cyanide	.082	.034
Lead	.118	.056
*Nickel	.540	.357
Zinc	.410	.172
*Ammonia	37.500	16.500
*Fluoride	16.700	7.420
Zirconium	8.090	3.910

PSES

Zirconium-Hafnium Forming
Sawing or Grinding Contact Cooling Water

Pollutant or pollutant property	Maximum for any one day	Maximum for monthly average
mg/off-kg (lb/million off-lbs) of zirconium-hafnium sawed or ground with contact cooling water		
*Chromium	.141	.058
Copper	.610	.321
*Cyanide	.093	.039
Lead	.135	.064
*Nickel	.617	.408
Zinc	.469	.196
*Ammonia	42.800	18.800
*Fluoride	19.100	8.480
Zirconium	9.250	4.460

Table XII-21 (Continued)

ZIRCONIUM-HAFNIUM FORMING SUBCATEGORY
 PRETREATMENT STANDARDS FOR EXISTING SOURCES

PSES

Zirconium-Hafnium Forming
 Sawing or Grinding Rinse

Pollutant or pollutant property	Maximum for any one day	Maximum for monthly average
mg/off-kg (lb/million off-lbs) of sawed or ground zirconium-hafnium rinsed		
*Chromium	.079	.032
Copper	.342	.180
*Cyanide	.052	.022
Lead	.076	.036
*Nickel	.346	.229
Zinc	.263	.110
*Ammonia	24.000	10.600
*Fluoride	10.700	4.750
Zirconium	5.190	2.500

PSES

Zirconium-Hafnium Forming
 Inspection and Testing Wastewater

Pollutant or pollutant property	Maximum for any one day	Maximum for monthly average
mg/off-kg (lb/million off-lbs) of zirconium-hafnium tested		
*Chromium	.007	.003
Copper	.029	.015
*Cyanide	.004	.002
Lead	.006	.003
*Nickel	.030	.020
Zinc	.023	.009
*Ammonia	2.050	.903
*Fluoride	.917	.407
Zirconium	.444	.214

Table XII-21 (Continued)

ZIRCONIUM-HAFNIUM FORMING SUBCATEGORY
PRETREATMENT STANDARDS FOR EXISTING SOURCES

PSES

Zirconium-Hafnium Forming
Degreasing Spent Solvents

There shall be no discharge of process wastewater pollutants.

PSES

Zirconium-Hafnium Forming
Wet Air Pollution Control Blowdown

There shall be no allowance for the discharge of process wastewater pollutants.

PSES

Zirconium-Hafnium Forming
Degreasing Rinse

There shall be no discharge of process wastewater pollutants.

Table XII-22

METAL POWDERS SUBCATEGORY
 PRETREATMENT STANDARDS FOR EXISTING SOURCES

PSES
 Metal Powders
 Metal Powder Production Atomization Wastewater

Pollutant or pollutant property	Maximum for any one day	Maximum for monthly average
mg/off-kg (lb/million off-lbs) of powder wet atomized		
Chromium	2.220	.907
*Copper	9.580	5.040
*Cyanide	1.460	.605
*Lead	2.120	1.010
Nickel	9.680	6.400
Zinc	7.360	3.080
Aluminum	32.400	16.100
Iron	6.050	3.080

PSES
 Metal Powders
 Tumbling, Burnishing, or Cleaning Wastewater

Pollutant or pollutant property	Maximum for any one day	Maximum for monthly average
mg/off-kg (lb/million off-lbs) of powder metallurgy parts tumbled, burnished, or cleaned		
Chromium	1.940	.792
*Copper	8.360	4.400
*Cyanide	1.280	.528
*Lead	1.850	.880
Nickel	8.450	5.590
Zinc	6.430	2.690
Aluminum	28.300	14.100
Iron	5.280	2.690

Table XII-22 (Continued)

METAL POWDERS SUBCATEGORY
 PRETREATMENT STANDARDS FOR EXISTING SOURCES

PSES
 Metal Powders
 Sawing or Grinding Spent Neat Oils

There shall be no discharge of process wastewater
 pollutants.

PSES
 Metal Powders
 Sawing or Grinding Spent Emulsions

Pollutant or pollutant property	Maximum for any one day	Maximum for monthly average
mg/off-kg (lb/million off-lbs) of powder metallurgy parts sawed or ground with emulsions		
Chromium	.008	.003
*Copper	.034	.018
*Cyanide	.005	.002
*Lead	.008	.004
Nickel	.035	.023
Zinc	.026	.011
Aluminum	.117	.058
Iron	.022	.011

PSES
 Metal Powders
 Sawing or Grinding Contact Cooling Water

Pollutant or pollutant property	Maximum for any one day	Maximum for monthly average
mg/off-kg (lb/million off-lbs) of powder metallurgy parts sawed or ground with contact cooling water		
Chromium	.713	.292
*Copper	3.080	1.620
*Cyanide	.470	.195
*Lead	.681	.324
Nickel	3.110	2.060
Zinc	2.370	.988
Aluminum	10.400	5.190
Iron	1.950	.988

Table XII-22 (Continued)

METAL POWDERS SUBCATEGORY
 PRETREATMENT STANDARDS FOR EXISTING SOURCES

PSES
 Metal Powders
 Sizing Spent Neat Oils

There shall be no discharge of process wastewater pollutants.

PSES
 Metal Powders
 Sizing Spent Emulsions

Pollutant or pollutant property	Maximum for any one day	Maximum for monthly average
mg/off-kg (lb/million off-lbs) of powder sized		
Chromium	.006	.003
*Copper	.028	.015
*Cyanide	.004	.002
*Lead	.006	.003
Nickel	.028	.019
Zinc	.021	.009
Aluminum	.094	.047
Iron	.018	.009

PSES
 Metal Powders
 Steam Treatment Wet Air Pollution Control Blowdown

Pollutant or pollutant property	Maximum for any one day	Maximum for monthly average
mg/off-kg (lb/million off-lbs) of powder metallurgy parts steam treated		
Chromium	.349	.143
*Copper	1.510	.792
*Cyanide	.230	.095
*Lead	.333	.159
Nickel	1.520	1.010
Zinc	1.160	.483
Aluminum	5.090	2.540
Iron	.951	.483

Table XII-22 (Continued)

METAL POWDERS SUBCATEGORY
 PRETREATMENT STANDARDS FOR EXISTING SOURCES

PSES
 Metal Powders
 Oil-Resin Impregnation Spent Neat Oils

There shall be no discharge of process wastewater pollutants.

PSES
 Metal Powders
 Degreasing Spent Solvents

There shall be no discharge of process wastewater pollutants.

PSES
 Metal Powders
 Hot Pressing Contact Cooling Water

Pollutant or pollutant property	Maximum for any one day	Maximum for monthly average
mg/off-kg (lb/million off-lbs) of powder cooled after pressing		
Chromium	3.870	1.590
*Copper	16.700	8.800
*Cyanide	2.550	1.060
*Lead	3.700	1.760
Nickel	16.900	11.200
Zinc	12.900	5.370
Aluminum	56.600	28.200
Iron	10.600	5.370

Table XII-22 (Continued)

METAL POWDERS SUBCATEGORY
 PRETREATMENT STANDARDS FOR EXISTING SOURCES

PSES

Metal Powders

Mixing Wet Air Pollution Control Blowdown

Pollutant or pollutant property	Maximum for any one day	Maximum for monthly average
mg/off-kg (lb/million off-lbs) of powder mixed		
Chromium	3.480	1.420
*Copper	15.000	7.900
*Cyanide	2.290	.948
*Lead	3.320	1.580
Nickel	15.200	10.100
Zinc	11.600	4.820
Aluminum	50.800	25.300
Iron	9.480	4.820

Table XII-23

LEAD-TIN-BISMUTH FORMING SUBCATEGORY
 PRETREATMENT STANDARDS FOR NEW SOURCES

PSNS
 Lead-Tin-Bismuth Forming
 Rolling Spent Emulsions

Pollutant or pollutant property	Maximum for any one day	Maximum for monthly average
mg/off-kg (lb/million off-lbs) of lead-tin-bismuth rolled with emulsions		
*Antimony	.067	.030
*Lead	.010	.005

PSNS
 Lead-Tin-Bismuth Forming
 Rolling Spent Soap Solutions

Pollutant or pollutant property	Maximum for any one day	Maximum for monthly average
mg/off-kg (lb/million off-lbs) of lead-tin-bismuth rolled with soap solutions		
*Antimony	.124	.055
*Lead	.018	.009

PSNS
 Lead-Tin-Bismuth Forming
 Drawing Spent Neat Oils

There shall be no discharge of process wastewater
 pollutants.

Table XII-23 (Continued)

LEAD-TIN-BISMUTH FORMING SUBCATEGORY
PRETREATMENT STANDARDS FOR NEW SOURCES

PSNS

Lead-Tin-Bismuth Forming
Drawing Spent Emulsions

Pollutant or pollutant property	Maximum for any one day	Maximum for monthly average
mg/off-kg (lb/million off-lbs) of lead-tin-bismuth drawn with emulsions		
*Antimony	.076	.034
*Lead	.011	.005

PSNS

Lead-Tin-Bismuth Forming
Drawing Spent Soap Solutions

Pollutant or pollutant property	Maximum for any one day	Maximum for monthly average
mg/off-kg (lb/million off-lbs) of lead-tin-bismuth drawn with soap solutions		
*Antimony	.021	.010
*Lead	.003	.001

PSNS

Lead-Tin-Bismuth Forming
Extrusion Press or Solution Heat Treatment Contact
Cooling Water

Pollutant or pollutant property	Maximum for any one day	Maximum for monthly average
mg/off-kg (lb/million off-lbs) of lead-tin-bismuth heat treated		
*Antimony	.413	.185
*Lead	.061	.029

Table XII-23

LEAD-TIN-BISMUTH FORMING SUBCATEGORY
 PRETREATMENT STANDARDS FOR NEW SOURCES

PSNS

Lead-Tin-Bismuth Forming
 Extrusion Press Hydraulic Fluid Leakage

Pollutant or pollutant property	Maximum for any one day	Maximum for monthly average
mg/off-kg (lb/million off-lbs) of lead-tin-bismuth extruded		
*Antimony	.158	.070
*Lead	.023	.011

PSNS

Lead-Tin-Bismuth Forming
 Swaging Spent Emulsions

Pollutant or pollutant property	Maximum for any one day	Maximum for monthly average
mg/off-kg (lb/million off-lbs) of lead-tin-bismuth swaged with emulsions		
*Antimony	.0051	.0023
*Lead	.0008	.0004

PSNS

Lead-Tin-Bismuth Forming
 Continuous Strip Casting Contact Cooling Water

Pollutant or pollutant property	Maximum for any one day	Maximum for monthly average
mg/off-kg (lb/million off-lbs) of lead-tin-bismuth cast by the continuous strip method		
*Antimony	.0029	.0013
*Lead	.0004	.0002

Table XII-23

LEAD-TIN-BISMUTH FORMING SUBCATEGORY
 PRETREATMENT STANDARDS FOR NEW SOURCES

PSNS
 Lead-Tin-Bismuth Forming
 Semi-Continuous Ingot Casting Contact Cooling Water

Pollutant or pollutant property	Maximum for any one day	Maximum for monthly average
mg/off-kg (lb/million off-lbs) of lead-tin-bismuth ingot cast by the semi-continuous method		
*Antimony	.008	.004
*Lead	.001	.001

PSNS
 Lead-Tin-Bismuth Forming
 Shot Casting Contact Cooling Water

Pollutant or pollutant property	Maximum for any one day	Maximum for monthly average
mg/off-kg (lb/million off-lbs) of lead-tin-bismuth shot cast		
*Antimony	.107	.048
*Lead	.016	.007

PSNS
 Lead-Tin-Bismuth Forming
 Shot-Forming Wet Air Pollution Control Blowdown

Pollutant or pollutant property	Maximum for any one day	Maximum for monthly average
mg/off-kg (lb/million off-lbs) of lead-tin-bismuth shot formed		
*Antimony	.169	.075
*Lead	.025	.012

Table XII-23

LEAD-TIN-BISMUTH FORMING SUBCATEGORY
 PRETREATMENT STANDARDS FOR NEW SOURCES

PSNS
 Lead-Tin-Bismuth Forming
 Alkaline Cleaning Spent Baths

Pollutant or pollutant property	Maximum for any one day	Maximum for monthly average
mg/off-kg (lb/million off-lbs) of lead-tin-bismuth alkaline cleaned		
*Antimony	.345	.154
*Lead	.050	.024

PSNS
 Lead-Tin-Bismuth Forming
 Alkaline Cleaning Rinse

Pollutant or pollutant property	Maximum for any one day	Maximum for monthly average
mg/off-kg (lb/million off-lbs) of lead-tin-bismuth alkaline cleaned		
*Antimony	.678	.302
*Lead	.099	.047

PSNS
 Lead-Tin-Bismuth Forming
 Degreasing Spent Solvents

There shall be no discharge of process wastewater
 pollutants.

Table XII-24

MAGNESIUM FORMING SUBCATEGORY
PRETREATMENT STANDARDS FOR NEW SOURCES

PSNS
Magnesium Forming
Rolling Spent Emulsions

Pollutant or pollutant property	Maximum for any one day	Maximum for monthly average
mg/off-kg (lb/million off-lbs) of magnesium rolled with emulsions		
*Chromium	.028	.011
*Zinc	.076	.031
*Ammonia	9.950	4.370
*Fluoride	4.440	1.970
Magnesium	.005	---

PSNS
Magnesium Forming
Forging Spent Lubricants

There shall be no discharge of process wastewater
pollutants.

PSNS
Magnesium Forming
Forging Contact Cooling Water

Pollutant or pollutant property	Maximum for any one day	Maximum for monthly average
mg/off-kg (lb/million off-lbs) of forged magnesium cooled with water		
*Chromium	.107	.043
*Zinc	.295	.122
*Ammonia	38.500	17.000
*Fluoride	17.200	7.630
Magnesium	.019	---

Table XII-24 (Continued)

MAGNESIUM FORMING SUBCATEGORY
 PRETREATMENT STANDARDS FOR NEW SOURCES

PSNS
 Magnesium Forming
 Forging Equipment Cleaning Wastewater

Pollutant or pollutant property	Maximum for any one day	Maximum for monthly average
mg/off-kg (lb/million off-lbs) of magnesium forged		
*Chromium	.0015	.0006
*Zinc	.0041	.0017
*Ammonia	.5320	.2340
*Fluoride	.2380	.1060
Magnesium	.0003	---

PSNS
 Magnesium Forming
 Direct Chill Casting Contact Cooling Water

Pollutant or pollutant property	Maximum for any one day	Maximum for monthly average
mg/off-kg (lb/million off-lbs) of magnesium cast with direct chill methods		
*Chromium	1.460	.593
*Zinc	4.030	1.660
*Ammonia	527.000	232.000
*Fluoride	235.000	104.000
Magnesium	.265	---

Table XII-24 (Continued)

MAGNESIUM FORMING SUBCATEGORY
 PRETREATMENT STANDARDS FOR NEW SOURCES

PSNS
 Magnesium Forming
 Surface Treatment Spent Baths

Pollutant or pollutant property	Maximum for any one day	Maximum for monthly average
mg/off-kg (lb/million off-lbs) of magnesium surface treated		
*Chromium	.173	.070
*Zinc	.476	.196
*Ammonia	62.100	27.300
*Fluoride	27.700	12.300
Magnesium	.031	---

PSNS
 Magnesium Forming
 Surface Treatment Rinse

Pollutant or pollutant property	Maximum for any one day	Maximum for monthly average
mg/off-kg (lb/million off-lbs) of magnesium surface treated		
*Chromium	.700	.284
*Zinc	1.930	.794
*Ammonia	252.000	111.000
*Fluoride	113.000	49.900
Magnesium	.127	---

Table XII-24 (Continued)

MAGNESIUM FORMING SUBCATEGORY
PRETREATMENT STANDARDS FOR NEW SOURCES

PSNS

Magnesium Forming
Sawing or Grinding Spent Emulsions

Pollutant or pollutant property	Maximum for any one day	Maximum for monthly average
mg/off-kg (lb/million off-lbs) of magnesium sawed or ground		
*Chromium	.007	.003
*Zinc	.020	.008
*Ammonia	2.600	1.140
*Fluoride	1.160	.515
Magnesium	.001	---

PSNS

Magnesium Forming
Degreasing Spent Solvents

There shall be no discharge of process wastewater
pollutants.

PSNS

Magnesium Forming
Wet Air Pollution Control Blowdown

Pollutant or pollutant property	Maximum for any one day	Maximum for monthly average
mg/off-kg (lb/million off-lbs) of magnesium formed		
*Chromium	.229	.093
*Zinc	.632	.260
*Ammonia	82.500	36.300
*Fluoride	36.900	16.400
Magnesium	.042	---

Table XII-25

NICKEL-COBALT FORMING SUBCATEGORY
 PRETREATMENT STANDARDS FOR NEW SOURCES

PSNS
 Nickel-Cobalt Forming
 Rolling Spent Neat Oils

There shall be no discharge of process wastewater pollutants.

PSNS
 Nickel-Cobalt Forming
 Rolling Spent Emulsions

Pollutant or pollutant property	Maximum for any one day	Maximum for monthly average
mg/off-kg (lb/million off-lbs) of nickel-cobalt rolled with emulsions		
Cadmium	.034	.014
*Chromium	.063	.026
Copper	.218	.104
Lead	.048	.022
*Nickel	.094	.063
Zinc	.174	.071
*Fluoride	10.100	4.490

PSNS
 Nickel-Cobalt Forming
 Rolling Contact Cooling Water

Pollutant or pollutant property	Maximum for any one day	Maximum for monthly average
mg/off-kg (lb/million off-lbs) of nickel-cobalt rolled with water		
Cadmium	.015	.006
*Chromium	.028	.011
Copper	.097	.046
Lead	.021	.010
*Nickel	.042	.028
Zinc	.077	.032
*Fluoride	4.490	1.990

Table XII-25 (Continued)

NICKEL-COBALT FORMING SUBCATEGORY
 PRETREATMENT STANDARDS FOR NEW SOURCES

PSNS
 Nickel-Cobalt Forming
 Tube Reducing Spent Lubricants

There shall be no discharge of process wastewater pollutants.

PSNS
 Nickel-Cobalt Forming
 Drawing Spent Neat Oils

There shall be no discharge of process wastewater pollutants.

PSNS
 Nickel-Cobalt Forming
 Drawing Spent Emulsions

Pollutant or pollutant property	Maximum for any one day	Maximum for monthly average
mg/off-kg (lb/million off-lbs) of nickel-cobalt drawn with emulsions		
Cadmium	.019	.008
*Chromium	.035	.014
Copper	.122	.058
Lead	.027	.012
*Nickel	.053	.035
Zinc	.097	.040
*Fluoride	5.680	2.520

PSNS
 Nickel-Cobalt Forming
 Extrusion Spent Lubricants

There shall be no discharge of process wastewater pollutants.

Table XII-25 (Continued)

NICKEL-COBALT FORMING SUBCATEGORY
 PRETREATMENT STANDARDS FOR NEW SOURCES

PSNS

Nickel-Cobalt Forming
 Extrusion Press or Solution Heat Treatment Contract
 Cooling Water

Pollutant or pollutant property	Maximum for any one day	Maximum for monthly average
mg/off-kg (lb/million off-lbs) of nickel-cobalt heat treated		
Cadmium	.017	.007
*Chromium	.031	.013
Copper	.107	.051
Lead	.023	.011
*Nickel	.046	.031
Zinc	.085	.035
*Fluoride	4.950	2.200

PSNS

Nickel-Cobalt Forming
 Extrusion Press Hydraulic Fluid Leakage

Pollutant or pollutant property	Maximum for any one day	Maximum for monthly average
mg/off-kg (lb/million off-lbs) of nickel-cobalt extruded		
Cadmium	.046	.019
*Chromium	.086	.035
Copper	.297	.142
Lead	.065	.030
*Nickel	.128	.086
Zinc	.237	.098
*Fluoride	13.800	6.130

PSNS

Nickel-Cobalt Forming
 Forging Spent Lubricants

There shall be no discharge of process wastewater pollutants.

Table XII-25 (Continued)

NICKEL-COBALT FORMING SUBCATEGORY
 PRETREATMENT STANDARDS FOR NEW SOURCES

PSNS

Nickel-Cobalt Forming
 Forging Contact Cooling Water

Pollutant or pollutant property	Maximum for any one day	Maximum for monthly average
mg/off-kg (lb/million off-lbs) of forged nickel-cobalt cooled with water		
Cadmium	.009	.004
*Chromium	.018	.007
Copper	.061	.029
Lead	.013	.006
*Nickel	.026	.018
Zinc	.048	.020
*Fluoride	2.820	1.250

PSNS

Nickel-Cobalt Forming
 Forging Equipment Cleaning Wastewater

Pollutant or pollutant property	Maximum for any one day	Maximum for monthly average
mg/off-kg (lb/million off-lbs) of nickel-cobalt forged		
Cadmium	.0008	.0003
*Chromium	.0015	.0006
Copper	.0051	.0024
Lead	.0011	.0005
*Nickel	.0022	.0015
Zinc	.0041	.0017
*Fluoride	.2380	.1060

Table XII-25 (Continued)

NICKEL-COBALT FORMING SUBCATEGORY
 PRETREATMENT STANDARDS FOR NEW SOURCES

PSNS

Nickel-Cobalt Forming

Forging Press Hydraulic Fluid Leakage

Pollutant or pollutant property	Maximum for any one day	Maximum for monthly average
mg/off-kg (lb/million off-lbs) of nickel-cobalt forged		
Cadmium	.037	.015
*Chromium	.069	.028
Copper	.240	.114
Lead	.052	.024
*Nickel	.103	.069
Zinc	.191	.079
*Fluoride	11.100	4.940

PSNS

Nickel-Cobalt Forming

Metal Powder Production Atomization Wastewater

Pollutant or pollutant property	Maximum for any one day	Maximum for monthly average
mg/off-kg (lb/million off-lbs) of nickel-cobalt metal powder atomized		
Cadmium	.524	.210
*Chromium	.970	.393
Copper	3.360	1.600
Lead	.734	.341
*Nickel	1.440	.970
Zinc	2.670	1.100
*Fluoride	156.000	69.200

Table XII-25 (Continued)

NICKEL-COBALT FORMING SUBCATEGORY
 PRETREATMENT STANDARDS FOR NEW SOURCES

PSNS
 Nickel-Cobalt Forming
 Stationary Casting Contact Cooling Water

Pollutant or pollutant property	Maximum for any one day	Maximum for monthly average
mg/off-kg (lb/million off-lbs) of nickel-cobalt cast with stationary casting methods		
Cadmium	.242	.097
*Chromium	.448	.182
Copper	1.550	.738
Lead	.339	.158
*Nickel	.666	.448
Zinc	1.240	.508
*Fluoride	72.000	32.000

PSNS
 Nickel-Cobalt Forming
 Vacuum Melting Steam Condensate

There shall be no allowance for the discharge of
 process wastewater pollutants.

PSNS
 Nickel-Cobalt Forming
 Annealing and Solution Heat Treatment Contact Cooling Water

There shall be no allowance for the discharge of
 process wastewater pollutants.

Table XII-25 (Continued)

NICKEL-COBALT FORMING SUBCATEGORY
 PRETREATMENT STANDARDS FOR NEW SOURCES

PSNS
 Nickel-Cobalt Forming
 Surface Treatment Spent Baths

Pollutant or pollutant property	Maximum for any one day	Maximum for monthly average
mg/off-kg (lb/million off-lbs) of nickel-cobalt surface treated		
Cadmium	.187	.075
*Chromium	.346	.140
Copper	1.200	.571
Lead	.262	.122
*Nickel	.514	.346
Zinc	.954	.393
*Fluoride	55.700	24.700

PSNS
 Nickel-Cobalt Forming
 Surface Treatment Rinse

Pollutant or pollutant property	Maximum for any one day	Maximum for monthly average
mg/off-kg (lb/million off-lbs) of nickel-cobalt surface treated		
Cadmium	.472	.189
*Chromium	.873	.354
Copper	3.020	1.440
Lead	.661	.307
*Nickel	1.300	.873
Zinc	2.410	.991
*Fluoride	141.000	62.300

Table XII-25 (Continued)

NICKEL-COBALT FORMING SUBCATEGORY
PRETREATMENT STANDARDS FOR NEW SOURCES

PSNS
Nickel-Cobalt Forming
Ammonia Rinse

Pollutant or pollutant property	Maximum for any one day	Maximum for monthly average
mg/off-kg (lb/million off-lbs) of nickel-cobalt treated with ammonia solution		
Cadmium	.003	.001
*Chromium	.005	.002
Copper	.019	.009
Lead	.004	.002
*Nickel	.008	.005
Zinc	.015	.006
*Fluoride	.881	.391

PSNS
Nickel-Cobalt Forming
Alkaline Cleaning Spent Baths

Pollutant or pollutant property	Maximum for any one day	Maximum for monthly average
mg/off-kg (lb/million off-lbs) of nickel-cobalt alkaline cleaned		
Cadmium	.007	.003
*Chromium	.013	.005
Copper	.043	.021
Lead	.009	.004
*Nickel	.019	.013
Zinc	.035	.014
*Fluoride	2.020	.895

Table XII-25 (Continued)

NICKEL-COBALT FORMING SUBCATEGORY
 PRETREATMENT STANDARDS FOR NEW SOURCES

PSNS

Nickel-Cobalt Forming
 Alkaline Cleaning Rinse

Pollutant or pollutant property	Maximum for any one day	Maximum for monthly average
mg/off-kg (lb/million off-lbs) of nickel-cobalt alkaline cleaned		
Cadmium	.047	.019
*Chromium	.086	.035
Copper	.298	.142
Lead	.065	.030
*Nickel	.128	.086
Zinc	.238	.098
*Fluoride	13.900	6.150

PSNS

Nickel-Cobalt Forming
 Molten Salt Rinse

Pollutant or pollutant property	Maximum for any one day	Maximum for monthly average
mg/off-kg (lb/million off-lbs) of nickel-cobalt treated with molten salt		
Cadmium	.169	.068
*Chromium	.312	.127
Copper	1.080	.515
Lead	.237	.110
*Nickel	.464	.312
Zinc	.861	.355
*Fluoride	50.200	22.300

Table XII-25 (Continued)

NICKEL-COBALT FORMING SUBCATEGORY
 PRETREATMENT STANDARDS FOR NEW SOURCES

PSNS
 Nickel-Cobalt Forming
 Sawing or Grinding Spent Emulsions

Pollutant or pollutant property	Maximum for any one day	Maximum for monthly average
mg/off-kg (lb/million off-lbs) of nickel-cobalt sawed or ground with emulsions		
Cadmium	.008	.003
*Chromium	.015	.006
Copper	.051	.024
Lead	.011	.005
*Nickel	.022	.015
Zinc	.040	.017
*Fluoride	2.350	1.040

PSNS
 Nickel-Cobalt Forming
 Sawing or Grinding Rinse

Pollutant or pollutant property	Maximum for any one day	Maximum for monthly average
mg/off-kg (lb/million off-lbs) of sawed or ground nickel-cobalt rinsed		
Cadmium	.036	.015
*Chromium	.067	.027
Copper	.232	.111
Lead	.051	.024
*Nickel	.100	.067
Zinc	.185	.076
*Fluoride	10.800	4.780

Table XII-25 (Continued)

NICKEL-COBALT FORMING SUBCATEGORY
 PRETREATMENT STANDARDS FOR NEW SOURCES

PSNS
 Nickel-Cobalt Forming
 Steam Cleaning Condensate

Pollutant or pollutant property	Maximum for any one day	Maximum for monthly average
mg/off-kg (lb/million off-lbs) of nickel-cobalt steam cleaned		
Cadmium	.006	.002
*Chromium	.011	.005
Copper	.039	.018
Lead	.008	.004
*Nickel	.017	.011
Zinc	.031	.013
*Fluoride	1.790	.795

PSNS
 Nickel-Cobalt Forming
 Hydrostatic Tube Testing and Ultrasonic Testing Wastewater

There shall be no allowance for the discharge of
 process wastewater pollutants.

PSNS
 Nickel-Cobalt Forming
 Dye Penetrant Testing Wastewater

Pollutant or pollutant property	Maximum for any one day	Maximum for monthly average
mg/off-kg (lb/million off-lbs) of nickel-cobalt tested with dye penetrant methods		
Cadmium	.043	.017
*Chromium	.079	.032
Copper	.273	.130
Lead	.060	.028
*Nickel	.117	.079
Zinc	.217	.090
*Fluoride	12.700	5.630

Table XII-25 (Continued)

NICKEL-COBALT FORMING SUBCATEGORY
 PRETREATMENT STANDARDS FOR NEW SOURCES

PSNS
 Nickel-Cobalt Forming
 Miscellaneous Wastewater Sources

Pollutant or pollutant property	Maximum for any one day	Maximum for monthly average
mg/off-kg (lb/million off-lbs) of nickel-cobalt formed		
Cadmium	.049	.020
*Chromium	.091	.037
Copper	.315	.150
Lead	.069	.032
*Nickel	.136	.091
Zinc	.251	.104
*Fluoride	14.700	6.500

PSNS
 Nickel-Cobalt Forming
 Degreasing Spent Solvents

There shall be no discharge of process wastewater pollutants.

PSNS
 Nickel-Cobalt Forming
 Wet Air Pollution Control Blowdown

Pollutant or pollutant property	Maximum for any one day	Maximum for monthly average
mg/off-kg (lb/million off-lbs) of nickel-cobalt formed		
Cadmium	.162	.065
*Chromium	.300	.122
Copper	1.040	.494
Lead	.227	.106
*Nickel	.446	.300
Zinc	.826	.340
*Fluoride	48.200	21.400

Table XII-25 (Continued)

NICKEL-COBALT FORMING SUBCATEGORY
 PRETREATMENT STANDARDS FOR NEW SOURCES

PSNS
 Nickel-Cobalt Forming
 Electrocoating Rinse

Pollutant or pollutant property	Maximum for any one day	Maximum for monthly average
mg/off-kg (lb/million off-lbs) of nickel-cobalt electrocoated		
Cadmium	.674	.270
*Chromium	1.250	.506
Copper	4.320	2.060
Lead	.944	.438
*Nickel	1.860	1.250
Zinc	3.440	1.420
*Fluoride	201.000	89.000

Table XII-26

PRECIOUS METALS FORMING SUBCATEGORY
 PRETREATMENT STANDARDS FOR NEW SOURCES

PSNS
 Precious Metals Forming
 Rolling Spent Neat Oils

There shall be no discharge of process wastewater
 pollutants.

PSNS
 Precious Metals Forming
 Rolling Spent Emulsions

Pollutant or pollutant property	Maximum for any one day	Maximum for monthly average
mg/off-kg (lb/million off-lbs) of precious metals rolled with emulsions		
*Cadmium	.026	.012
Chromium	.034	.014
*Copper	.147	.077
*Cyanide	.022	.009
*Lead	.032	.015
Nickel	.148	.098
*Silver	.032	.013
Zinc	.113	.047

PSNS
 Precious Metals Forming
 Drawing Spent Neat Oils

There shall be no discharge of process wastewater
 pollutants.

Table XII-26 (Continued)

PRECIOUS METALS FORMING SUBCATEGORY
 PRETREATMENT STANDARDS FOR NEW SOURCES

PSNS
 Precious Metals Forming
 Drawing Spent Emulsions

Pollutant or pollutant property	Maximum for any one day	Maximum for monthly average
mg/off-kg (lb/million off-lbs) of precious metals drawn with emulsions		
*Cadmium	.016	.007
Chromium	.021	.009
*Copper	.090	.048
*Cyanide	.014	.006
*Lead	.020	.010
Nickel	.091	.060
*Silver	.020	.008
Zinc	.069	.029

PSNS
 Precious Metals Forming
 Drawing Spent Soap Solutions

Pollutant or pollutant property	Maximum for any one day	Maximum for monthly average
mg/off-kg (lb/million off-lbs) of precious metals drawn with soap solutions		
*Cadmium	.0011	.0005
Chromium	.0014	.0006
*Copper	.0059	.0031
*Cyanide	.0009	.0004
*Lead	.0013	.0006
Nickel	.0060	.0040
*Silver	.0013	.0005
Zinc	.0046	.0019

Table XII-26 (Continued)

PRECIOUS METALS FORMING SUBCATEGORY
 PRETREATMENT STANDARDS FOR NEW SOURCES

PSNS
 Precious Metals Forming
 Metal Powder Production Atomization Wastewater

Pollutant or pollutant property	Maximum for any one day	Maximum for monthly average
mg/off-kg (lb/million off-lbs) of precious metals powder wet atomized		
*Cadmium	2.270	1.000
Chromium	2.940	1.200
*Copper	12.700	6.680
*Cyanide	1.940	.802
*Lead	2.810	1.340
Nickel	12.800	8.490
*Silver	2.740	1.140
Zinc	9.750	4.080

PSNS
 Precious Metals Forming
 Direct Chill Casting Contact Cooling Water

Pollutant or pollutant property	Maximum for any one day	Maximum for monthly average
mg/off-kg (lb/million off-lbs) of precious metals cast by the direct chill method		
*Cadmium	.367	.162
Chromium	.475	.195
*Copper	2.050	1.080
*Cyanide	.313	.130
*Lead	.454	.216
Nickel	2.080	1.370
*Silver	.443	.184
Zinc	1.580	.659

Table XII-26 (Continued)

PRECIOUS METALS FORMING SUBCATEGORY
 PRETREATMENT STANDARDS FOR NEW SOURCES

PSNS
 Precious Metals Forming
 Shot Casting Contact Cooling Water

Pollutant or pollutant property	Maximum for any one day	Maximum for monthly average
mg/off-kg (lb/million off-lbs) of precious metals shot cast		
*Cadmium	.125	.055
Chromium	.162	.066
*Copper	.698	.367
*Cyanide	.107	.044
*Lead	.154	.073
Nickel	.705	.466
*Silver	.151	.062
Zinc	.536	.224

PSNS
 Precious Metals Forming
 Stationary Casting Contact Cooling Water

There shall be no discharge of process wastewater
 pollutants.

PSNS
 Precious Metals Forming
 Semi-Continuous and Continuous Casting Contact
 Cooling Water

Pollutant or pollutant property	Maximum for any one day	Maximum for monthly average
mg/off-kg (lb/million off-lbs) of precious metals cast by the semi-continuous or continuous method		
*Cadmium	.350	.155
Chromium	.453	.186
*Copper	1.960	1.030
*Cyanide	.299	.124
*Lead	.433	.206
Nickel	1.980	1.310
*Silver	.423	.175
Zinc	1.510	.629

Table XII-26 (Continued)

PRECIOUS METALS FORMING SUBCATEGORY
 PRETREATMENT STANDARDS FOR NEW SOURCES

PSNS
 Precious Metals Forming
 Heat Treatment Contact Cooling Water

Pollutant or pollutant property	Maximum for any one day	Maximum for monthly average
mg/off-kg (lb/million off-lbs) of extruded precious metals heat treated		
*Cadmium	.142	.063
Chromium	.184	.075
*Copper	.793	.417
*Cyanide	.121	.050
*Lead	.175	.083
Nickel	.801	.530
*Silver	.171	.071
Zinc	.609	.255

PSNS
 Precious Metals Forming
 Surface Treatment Spent Baths

Pollutant or pollutant property	Maximum for any one day	Maximum for monthly average
mg/off-kg (lb/million off-lbs) of precious metals surface treated		
*Cadmium	.033	.015
Chromium	.042	.017
*Copper	.183	.096
*Cyanide	.028	.012
*Lead	.041	.019
Nickel	.185	.123
*Silver	.040	.016
Zinc	.141	.059

Table XII-26 (Continued)

PRECIOUS METALS FORMING SUBCATEGORY
PRETREATMENT STANDARDS FOR NEW SOURCES

PSNS

Precious Metals Forming
Surface Treatment Rinse

Pollutant or pollutant property	Maximum for any one day	Maximum for monthly average
mg/off-kg (lb/million off-lbs) of precious metals surface treated		
*Cadmium	.210	.092
Chromium	.271	.111
*Copper	1.170	.616
*Cyanide	.179	.074
*Lead	.259	.123
Nickel	1.180	.783
*Silver	.253	.105
Zinc	.900	.376

PSNS

Precious Metals Forming
Alkaline Cleaning Spent Baths

Pollutant or pollutant property	Maximum for any one day	Maximum for monthly average
mg/off-kg (lb/million off-lbs) of precious metals alkaline cleaned		
*Cadmium	.020	.009
Chromium	.026	.011
*Copper	.114	.060
*Cyanide	.017	.007
*Lead	.025	.012
Nickel	.115	.076
*Silver	.025	.010
Zinc	.088	.037

Table XII-26 (Continued)

PRECIOUS METALS FORMING SUBCATEGORY
 PRETREATMENT STANDARDS FOR NEW SOURCES

PSNS
 Precious Metals Forming
 Alkaline Cleaning Rinse

Pollutant or pollutant property	Maximum for any one day	Maximum for monthly average
mg/off-kg (lb/million off-lbs) of precious metals alkaline cleaned		
*Cadmium	.381	.168
Chromium	.493	.202
*Copper	2.130	1.120
*Cyanide	.325	.135
*Lead	.471	.224
Nickel	2.150	1.420
*Silver	.459	.191
Zinc	1.640	.683

PSNS
 Precious Metals Forming
 Alkaline Cleaning Prebonding Wastewater

Pollutant or pollutant property	Maximum for any one day	Maximum for monthly average
mg/off-kg (lb/million off-lbs) of precious metals and base metal cleaned prior to bonding		
*Cadmium	.395	.174
Chromium	.511	.209
*Copper	2.210	1.160
*Cyanide	.337	.139
*Lead	.487	.232
Nickel	2.230	1.480
*Silver	.476	.197
Zinc	1.700	.708

Table XII-26 (Continued)

PRECIOUS METALS FORMING SUBCATEGORY
 PRETREATMENT STANDARDS FOR NEW SOURCES

PSNS
 Precious Metals Forming
 Tumbling or Burnishing Wastewater

Pollutant or pollutant property	Maximum for any one day	Maximum for monthly average
mg/off-kg (lb/million off-lbs) of precious metals tumbled or burnished		
*Cadmium	.412	.182
Chromium	.533	.218
*Copper	2.300	1.210
*Cyanide	.351	.145
*Lead	.508	.242
Nickel	2.330	1.540
*Silver	.496	.206
Zinc	1.770	.738

PSNS
 Precious Metals Forming
 Sawing or Grinding Spent Neat Oils

There shall be no discharge of process wastewater
 pollutants.

PSNS
 Precious Metals Forming
 Sawing or Grinding Spent Emulsions

Pollutant or pollutant property	Maximum for any one day	Maximum for monthly average
mg/off-kg (lb/million off-lbs) of precious metals sawed or ground with emulsions		
*Cadmium	.032	.014
Chromium	.041	.017
*Copper	.178	.093
*Cyanide	.027	.011
*Lead	.039	.019
Nickel	.180	.119
*Silver	.038	.016
Zinc	.137	.057

Table XII-26 (Continued)

PRECIOUS METALS FORMING SUBCATEGORY
 PRETREATMENT STANDARDS FOR NEW SOURCES

PSNS
 Precious Metals Forming
 Pressure Bonding Contact Cooling Water

Pollutant or pollutant property	Maximum for any one day	Maximum for monthly average
mg/off-kg (lb/million off-lbs) of precious metals and base metal pressure bonded		
*Cadmium	.028	.013
Chromium	.037	.015
*Copper	.159	.084
*Cyanide	.024	.010
*Lead	.035	.017
Nickel	.161	.106
*Silver	.034	.014
Zinc	.122	.051

PSNS
 Precious Metals Forming
 Degreasing Spent Solvents

There shall be no discharge of process wastewater
 pollutants.

PSNS
 Precious Metals Forming
 Wet Air Pollution Control Blowdown

There shall be no discharge of process wastewater
 pollutants.

Table XII-27

REFRACTORY METALS FORMING SUBCATEGORY
PRETREATMENT STANDARDS FOR NEW SOURCES

PSNS

Refractory Metals Forming
Rolling Spent Neat Oils and Graphite-Based LubricantsThere shall be no discharge of process wastewater
pollutants.

PSNS

Refractory Metals Forming
Rolling Spent Emulsions

Pollutant or pollutant property	Maximum for any one day	Maximum for monthly average
mg/off-kg (lb/million off-lbs) of refractory metals rolled with emulsions		
Chromium	.159	.064
*Copper	.549	.262
Lead	.120	.056
*Nickel	.236	.159
Silver	.125	.052
Zinc	.438	.180
Columbium	.052	---
*Fluoride	25.500	11.300
*Molybdenum	2.160	.957
Tantalum	.193	---
Vanadium	.043	---
Tungsten	1.490	.665

PSNS

Refractory Metals Forming
Drawing Spent LubricantsThere shall be no discharge of process wastewater
pollutants.

Table XII-27 (Continued)

REFRACTORY METALS FORMING SUBCATEGORY
PRETREATMENT STANDARDS FOR NEW SOURCESPSNS
Refractory Metals Forming
Extrusion Spent Lubricants

There shall be no discharge of process wastewater pollutants.

PSNS
Refractory Metals Forming
Extrusion Press Hydraulic Fluid Leakage

Pollutant or pollutant property	Maximum for any one day	Maximum for monthly average
mg/off-kg (lb/million off-lbs) of refractory metals extruded		
Chromium	.441	.179
*Copper	1.530	.726
Lead	.333	.155
*Nickel	.655	.441
Silver	.345	.143
Zinc	1.220	.500
Columbium	.143	---
*Fluoride	70.800	31.400
*Molybdenum	5.990	2.660
Tantalum	.536	---
Vanadium	.119	---
Tungsten	4.140	1.850

PSNS
Refractory Metals Forming
Forging Spent Lubricants

There shall be no discharge of process wastewater pollutants.

Table XII-27 (Continued)

REFRACTORY METALS FORMING SUBCATEGORY
PRETREATMENT STANDARDS FOR NEW SOURCES

PSNS

Refractory Metals Forming
Forging Contact Cooling Water

Pollutant or pollutant property	Maximum for any one day	Maximum for monthly average
mg/off-kg (lb/million off-lbs) of forged refractory metals cooled with water		
Chromium	.012	.005
*Copper	.041	.020
Lead	.009	.004
*Nickel	.018	.012
Silver	.009	.004
Zinc	.033	.014
Columbium	.004	---
*Fluoride	1.920	.853
*Molybdenum	.163	.072
Tantalum	.015	---
Vanadium	.003	---
Tungsten	.113	.050

PSNS

Refractory Metals Forming
Metal Powder Production Wastewater

Pollutant or pollutant property	Maximum for any one day	Maximum for monthly average
mg/off-kg (lb/million off-lbs) of refractory metals powder produced		
Chromium	.104	.042
*Copper	.360	.172
Lead	.079	.037
*Nickel	.155	.104
Silver	.082	.034
Zinc	.287	.118
Columbium	.034	---
*Fluoride	16.700	7.420
*Molybdenum	1.420	.627
Tantalum	.127	---
Vanadium	.028	---
Tungsten	.978	.436

Table XII-27 (Continued)

REFRACTORY METALS FORMING SUBCATEGORY
 PRETREATMENT STANDARDS FOR NEW SOURCES

PSNS

Refractory Metals Forming
 Metal Powder Production Floor Wash Water

There shall be no discharge of process wastewater pollutants.

PSNS

Refractory Metals Forming
 Metal Powder Pressing Spent Lubricants

There shall be no discharge of process wastewater pollutants.

PSNS

Refractory Metals Forming
 Surface Treatment Spent Baths

Pollutant or pollutant property	Maximum for any one day	Maximum for monthly average
mg/off-kg (lb/million off-lbs) of refractory metals surface treated		
Chromium	.144	.058
*Copper	.498	.237
Lead	.109	.051
*Nickel	.214	.144
Silver	.113	.047
Zinc	.397	.164
Columbium	.047	---
*Fluoride	23.200	10.300
*Molybdenum	1.960	.868
Tantalum	.175	---
Vanadium	.039	---
Tungsten	1.360	.603

Table XII-27 (Continued)

REFRACTORY METALS FORMING SUBCATEGORY
PRETREATMENT STANDARDS FOR NEW SOURCES

PSNS

Refractory Metals Forming
Surface Treatment Rinse

Pollutant or pollutant property	Maximum for any one day	Maximum for monthly average
mg/off-kg (lb/million off-lbs) of refractory metals surface treated		
Chromium	4.480	1.820
*Copper	15.500	7.380
Lead	3.390	1.580
*Nickel	6.660	4.480
Silver	3.510	1.450
Zinc	12.400	5.080
Columbium	1.450	---
*Fluoride	720.000	320.000
*Molybdenum	60.900	27.000
Tantalum	5.450	---
Vanadium	1.210	---
Tungsten	42.100	18.800

PSNS

Refractory Metals Forming
Alkaline Cleaning Spent Baths

Pollutant or pollutant property	Maximum for any one day	Maximum for monthly average
mg/off-kg (lb/million off-lbs) of refractory metals alkaline cleaned		
Chromium	.124	.050
*Copper	.428	.204
Lead	.094	.043
*Nickel	.184	.124
Silver	.097	.040
Zinc	.341	.140
Columbium	.040	---
*Fluoride	19.900	8.820
*Molybdenum	1.680	.745
Tantalum	.151	---
Vanadium	.033	---
Tungsten	1.160	.518

Table XII-27 (Continued)

REFRACTORY METALS FORMING SUBCATEGORY
PRETREATMENT STANDARDS FOR NEW SOURCES

PSNS

Refractory Metals Forming
Alkaline Cleaning Rinse

Pollutant or pollutant property	Maximum for any one day	Maximum for monthly average
mg/off-kg (lb/million off-lbs) of refractory metals alkaline cleaned		
Chromium	3.020	1.230
*Copper	10.500	4.980
Lead	2.290	1.060
*Nickel	4.490	3.020
Silver	2.370	.979
Zinc	8.330	3.430
Columbium	.979	---
*Fluoride	486.000	216.000
*Molybdenum	41.100	18.200
Tantalum	3.670	---
Vanadium	.816	---
Tungsten	28.400	12.700

PSNS

Refractory Metals Forming
Molten Salt Rinse

Pollutant or pollutant property	Maximum for any one day	Maximum for monthly average
mg/off-kg (lb/million off-lbs) of refractory metals treated with molten salt		
Chromium	.234	.095
*Copper	.810	.386
Lead	.177	.082
*Nickel	.348	.234
Silver	.184	.076
Zinc	.646	.266
Columbium	.076	---
*Fluoride	37.700	16.700
*Molybdenum	3.190	1.410
Tantalum	.285	---
Vanadium	.063	---
Tungsten	2.200	.981

Table XII-27 (Continued)

REFRACTORY METALS FORMING SUBCATEGORY
PRETREATMENT STANDARDS FOR NEW SOURCES

PSNS

Refractory Metals Forming
Tumbling or Burnishing Wastewater

Pollutant or pollutant property	Maximum for any one day	Maximum for monthly average
mg/off-kg (lb/million off-lbs) of refractory metals tumbled or burnished		
Chromium	.463	.188
*Copper	1.600	.763
Lead	.350	.163
*Nickel	.688	.463
Silver	.363	.150
Zinc	1.280	.525
Columbium	.150	---
*Fluoride	74.400	33.000
*Molybdenum	6.290	2.790
Tantalum	.563	---
Vanadium	.125	---
Tungsten	4.350	1.940

PSNS

Refractory Metals Forming
Sawing or Grinding Spent Neat OilsThere shall be no discharge of process wastewater
pollutants.

Table XII-27 (Continued)

REFRACTORY METALS FORMING SUBCATEGORY
PRETREATMENT STANDARDS FOR NEW SOURCES

PSNS

Refractory Metals Forming
Sawing or Grinding Spent Emulsions

Pollutant or pollutant property	Maximum for any one day	Maximum for monthly average
mg/off-kg (lb/million off-lbs) of refractory metals sawed or ground with emulsions		
Chromium	.110	.045
*Copper	.380	.181
Lead	.083	.039
*Nickel	.164	.110
Silver	.086	.036
Zinc	.303	.125
Columbium	.036	---
*Fluoride	17.700	7.840
*Molybdenum	1.500	.663
Tantalum	.134	---
Vanadium	.030	---
Tungsten	1.040	.461

PSNS

Refractory Metals Forming
Sawing or Grinding Contact Cooling Water

Pollutant or pollutant property	Maximum for any one day	Maximum for monthly average
mg/off-kg (lb/million off-lbs) of refractory metals sawed or ground with contact cooling water		
Chromium	.899	.365
*Copper	3.110	1.480
Lead	.681	.316
*Nickel	1.340	.899
Silver	.705	.292
Zinc	2.480	1.020
Columbium	.292	---
*Fluoride	145.000	64.200
*Molybdenum	12.200	5.420
Tantalum	1.100	---
Vanadium	.243	---
Tungsten	8.460	3.770

Table XII-27 (Continued)

REFRACTORY METALS FORMING SUBCATEGORY
PRETREATMENT STANDARDS FOR NEW SOURCES

PSNS

Refractory Metals Forming
Sawing or Grinding Rinse

Pollutant or pollutant property	Maximum for any one day	Maximum for monthly average
mg/off-kg (lb/million off-lbs) of sawed or ground refractory metals rinsed		
Chromium	.005	.002
*Copper	.017	.008
Lead	.004	.002
*Nickel	.007	.005
Silver	.004	.002
Zinc	.014	.006
Columbium	.002	---
*Fluoride	.803	.357
*Molybdenum	.068	.030
Tantalum	.006	---
Vanadium	.001	---
Tungsten	.047	.021

PSNS

Refractory Metals Forming
Dye Penetrant Testing Wastewater

Pollutant or pollutant property	Maximum for any one day	Maximum for monthly average
mg/off-kg (lb/million off-lbs) of refractory metals tested with dye penetrant methods		
Chromium	.029	.012
*Copper	.099	.047
Lead	.022	.010
*Nickel	.043	.029
Silver	.023	.009
Zinc	.079	.033
Columbium	.009	---
*Fluoride	4.620	2.050
*Molybdenum	.391	.173
Tantalum	.035	---
Vanadium	.008	---
Tungsten	.270	.120

Table XII-27 (Continued)

REFRACTORY METALS FORMING SUBCATEGORY
PRETREATMENT STANDARDS FOR NEW SOURCESPSNS
Refractory Metals Forming
Equipment Cleaning Wastewater

Pollutant or pollutant property	Maximum for any one day	Maximum for monthly average
mg/off-kg (lb/million off-lbs) of refractory metals formed		
Chromium	.050	.020
*Copper	.174	.083
Lead	.038	.018
*Nickel	.075	.050
Silver	.040	.016
Zinc	.139	.057
Columbium	.016	---
*Fluoride	8.090	3.590
*Molybdenum	.684	.303
Tantalum	.061	---
Vanadium	.014	---
Tungsten	.473	.211

PSNS
Refractory Metals Forming
Miscellaneous Wastewater Sources

Pollutant or pollutant property	Maximum for any one day	Maximum for monthly average
mg/off-kg (lb/million off-lbs) of refractory metals formed		
Chromium	.128	.052
*Copper	.442	.211
Lead	.097	.045
*Nickel	.190	.128
Silver	.100	.041
Zinc	.352	.145
Columbium	.041	---
*Fluoride	20.500	9.110
*Molybdenum	1.740	.770
Tantalum	.155	---
Vanadium	.035	---
Tungsten	1.200	.535

Table XII-27 (Continued)

REFRACTORY METALS FORMING SUBCATEGORY
 PRETREATMENT STANDARDS FOR NEW SOURCES

PSNS

Refractory Metals Forming
 Degreasing Spent Solvents

There shall be no discharge of process wastewater
 pollutants.

PSNS

Refractory Metals Forming
 Wet Air Pollution Control Blowdown

Pollutant or pollutant property	Maximum for any one day	Maximum for monthly average
mg/off-kg (lb/million off-lbs) of refractory metals formed		
Chromium	.291	.118
*Copper	1.010	.480
Lead	.221	.103
*Nickel	.433	.291
Silver	.228	.095
Zinc	.803	.331
Columbium	.095	---
*Fluoride	46.800	20.800
*Molybdenum	3.960	1.760
Tantalum	.354	---
Vanadium	.079	---
Tungsten	2.740	1.220

Table XII-28

TITANIUM FORMING SUBCATEGORY
 PRETREATMENT STANDARDS FOR NEW SOURCES

PSNS
 Titanium Forming
 Rolling Spent Neat Oils

There shall be no discharge of process wastewater pollutants.

PSNS
 Titanium Forming
 Rolling Contact Cooling Water

Pollutant or pollutant property	Maximum for any one day	Maximum for monthly average
mg/off-kg (lb/million off-lbs) of titanium rolled with contact cooling water		
Chromium	.215	.088
Copper	.927	.488
*Cyanide	.142	.059
*Lead	.205	.098
Nickel	.937	.620
*Zinc	.713	.298
*Ammonia	65.100	28.600
*Fluoride	29.100	12.900
Titanium	.459	.200

PSNS
 Titanium Forming
 Drawing Spent Neat Oils

There shall be no discharge of process wastewater pollutants.

PSNS
 Titanium Forming
 Extrusion Spent Neat Oils

There shall be no discharge of process wastewater pollutants.

Table XII-28 (Continued)

TITANIUM FORMING SUBCATEGORY
 PRETREATMENT STANDARDS FOR NEW SOURCES

PSNS
 Titanium Forming
 Extrusion Spent Emulsions

Pollutant or pollutant property	Maximum for any one day	Maximum for monthly average
mg/off-kg (lb/million off-lbs) of titanium extruded with emulsions		
Chromium	.032	.013
Copper	.137	.072
*Cyanide	.021	.009
*Lead	.030	.014
Nickel	.138	.091
*Zinc	.105	.044
*Ammonia	9.590	4.220
*Fluoride	4.280	1.900
Titanium	.068	.030

PSNS
 Titanium Forming
 Extrusion Press Hydraulic Fluid Leakage

Pollutant or pollutant property	Maximum for any one day	Maximum for monthly average
mg/off-kg (lb/million off-lbs) of titanium extruded		
Chromium	.078	.032
Copper	.338	.178
*Cyanide	.052	.021
*Lead	.075	.036
Nickel	.342	.226
*Zinc	.260	.109
*Ammonia	23.700	10.500
*Fluoride	10.600	4.700
Titanium	.168	.073

Table XII-28 (Continued)

TITANIUM FORMING SUBCATEGORY
PRETREATMENT STANDARDS FOR NEW SOURCES

PSNS
Titanium Forming
Forging Spent Lubricants

There shall be no discharge of process wastewater
pollutants.

PSNS
Titanium Forming
Forging Contact Cooling Water

Pollutant or pollutant property	Maximum for any one day	Maximum for monthly average
mg/off-kg (lb/million off-lbs) of forged titanium cooled with water		
Chromium	.044	.018
Copper	.190	.100
*Cyanide	.029	.012
*Lead	.042	.020
Nickel	.192	.127
*Zinc	.146	.061
*Ammonia	13.300	5.860
*Fluoride	5.950	2.640
Titanium	.094	.041

PSNS
Titanium Forming
Forging Equipment Cleaning Wastewater

Pollutant or pollutant property	Maximum for any one day	Maximum for monthly average
mg/off-kg (lb/million off-lbs) of titanium forged		
Chromium	.018	.007
Copper	.076	.040
*Cyanide	.012	.005
*Lead	.017	.008
Nickel	.077	.051
*Zinc	.058	.024
*Ammonia	5.330	2.350
*Fluoride	2.380	1.060
Titanium	.038	.016

Table XII-28 (Continued)

TITANIUM FORMING SUBCATEGORY
 PRETREATMENT STANDARDS FOR NEW SOURCES

PSNS
 Titanium Forming
 Forging Press Hydraulic Fluid Leakage

Pollutant or pollutant property	Maximum for any one day	Maximum for monthly average
mg/off-kg (lb/million off-lbs) of titanium forged		
Chromium	.445	.182
Copper	1.920	1.010
*Cyanide	.293	.121
*Lead	.424	.202
Nickel	1.940	1.280
*Zinc	1.480	.616
*Ammonia	135.000	59.200
*Fluoride	60.100	26.700
Titanium	.950	.414

PSNS
 Titanium Forming
 Tube Reducing Spent Lubricants

There shall be no discharge of process wastewater
 pollutants.

PSNS
 Titanium Forming
 Heat Treatment Contact Cooling Water

There shall be no allowance for the discharge of
 process wastewater pollutants.

Table XII-28 (Continued)

TITANIUM FORMING SUBCATEGORY
 PRETREATMENT STANDARDS FOR NEW SOURCES

PSNS
 Titanium Forming
 Surface Treatment Spent Baths

Pollutant or pollutant property	Maximum for any one day	Maximum for monthly average
mg/off-kg (lb/million off-lbs) of titanium surface treated		
Chromium	.092	.038
Copper	.395	.208
*Cyanide	.060	.025
*Lead	.087	.042
Nickel	.400	.264
*Zinc	.304	.127
*Ammonia	27.700	12.200
*Fluoride	12.400	5.490
Titanium	.196	.085

PSNS
 Titanium Forming
 Surface Treatment Rinse

Pollutant or pollutant property	Maximum for any one day	Maximum for monthly average
mg/off-kg (lb/million off-lbs) of titanium surface treated		
Chromium	1.290	.526
Copper	5.550	2.920
*Cyanide	.847	.351
*Lead	1.230	.584
Nickel	5.610	3.710
*Zinc	4.270	1.780
*Ammonia	389.000	171.000
*Fluoride	174.000	77.100
Titanium	2.750	1.200

Table XII-28 (Continued)

TITANIUM FORMING SUBCATEGORY
 PRETREATMENT STANDARDS FOR NEW SOURCES

PSNS

Titanium Forming

Alkaline Cleaning Spent Baths

Pollutant or pollutant property	Maximum for any one day	Maximum for monthly average
mg/off-kg (lb/million off-lbs) of titanium alkaline cleaned		
Chromium	.106	.043
Copper	.456	.240
*Cyanide	.070	.029
*Lead	.101	.048
Nickel	.461	.305
*Zinc	.351	.147
*Ammonia	32.000	14.100
*Fluoride	14.300	6.340
Titanium	.226	.098

PSNS

Titanium Forming

Alkaline Cleaning Rinse

Pollutant or pollutant property	Maximum for any one day	Maximum for monthly average
mg/off-kg (lb/million off-lbs) of titanium alkaline cleaned		
Chromium	.122	.050
Copper	.525	.276
*Cyanide	.080	.033
*Lead	.116	.055
Nickel	.530	.351
*Zinc	.403	.169
*Ammonia	36.800	16.200
*Fluoride	16.400	7.290
Titanium	.260	.113

Table XII-28 (Continued)

TITANIUM FORMING SUBCATEGORY
PRETREATMENT STANDARDS FOR NEW SOURCES

PSNS
Titanium Forming
Molten Salt Rinse

Pollutant or pollutant property	Maximum for any one day	Maximum for monthly average
mg/off-kg (lb/million off-lbs) of titanium treated with molten salt		
Chromium	.420	.172
Copper	1.820	.955
*Cyanide	.277	.115
*Lead	.401	.191
Nickel	1.840	1.210
*Zinc	1.400	.583
*Ammonia	128.000	56.000
*Fluoride	56.800	25.200
Titanium	.898	.392

PSNS
Titanium Forming
Tumbling Wastewater

Pollutant or pollutant property	Maximum for any one day	Maximum for monthly average
mg/off-kg (lb/million off-lbs) of titanium tumbled		
Chromium	.035	.014
Copper	.150	.079
*Cyanide	.023	.009
*Lead	.033	.016
Nickel	.152	.101
*Zinc	.116	.048
*Ammonia	10.600	4.630
*Fluoride	4.700	2.090
Titanium	.074	.032

Table XII-28 (Continued)

TITANIUM FORMING SUBCATEGORY
 PRETREATMENT STANDARDS FOR NEW SOURCES

PSNS

Titanium Forming
 Sawing or Grinding Spent Neat Oils

There shall be no discharge of process wastewater pollutants.

PSNS

Titanium Forming
 Sawing or Grinding Spent Emulsions

Pollutant or pollutant property	Maximum for any one day	Maximum for monthly average
mg/off-kg (lb/million off-lbs) of titanium sawed or ground with emulsions		
Chromium	.081	.033
Copper	.348	.183
*Cyanide	.053	.022
*Lead	.077	.037
Nickel	.352	.233
*Zinc	.267	.112
*Ammonia	24.400	10.700
*Fluoride	10.900	4.830
Titanium	.172	.075

PSNS

Titanium Forming
 Sawing or Grinding Contact Cooling Water

Pollutant or pollutant property	Maximum for any one day	Maximum for monthly average
mg/off-kg (lb/million off-lbs) of titanium sawed or ground with contact cooling water		
Chromium	.210	.086
Copper	.905	.476
*Cyanide	.138	.057
*Lead	.200	.095
Nickel	.914	.605
*Zinc	.695	.291
*Ammonia	63.500	27.900
*Fluoride	28.300	12.600
Titanium	.448	.195

Table XII-28 (Continued)

TITANIUM FORMING SUBCATEGORY
 PRETREATMENT STANDARDS FOR NEW SOURCES

PSNS
 Titanium Forming
 Dye Penetrant Testing Wastewater

Pollutant or pollutant property	Maximum for any one day	Maximum for monthly average
mg/off-kg (lb/million off-lbs) of titanium tested with dye penetrant methods		
Chromium	.493	.202
Copper	2.130	1.120
*Cyanide	.325	.135
*Lead	.471	.224
Nickel	2.150	1.420
*Zinc	1.640	.683
*Ammonia	149.000	65.700
*Fluoride	66.700	29.600
Titanium	1.050	.459

PSNS
 Titanium Forming
 Miscellaneous Wastewater Sources

Pollutant or pollutant property	Maximum for any one day	Maximum for monthly average
mg/off-kg (lb/million off-lbs) of titanium formed		
Chromium	.014	.006
Copper	.062	.032
*Cyanide	.009	.004
*Lead	.014	.006
Nickel	.062	.041
*Zinc	.047	.020
*Ammonia	4.320	1.900
*Fluoride	1.930	.856
Titanium	.031	.013

Table XII-28 (Continued)

TITANIUM FORMING SUBCATEGORY
 PRETREATMENT STANDARDS FOR NEW SOURCES

PSNS
 Titanium Forming
 Degreasing Spent Solvents

There shall be no discharge of process wastewater pollutants.

PSNS
 Titanium Forming
 Wet Air Pollution Control Blowdown

Pollutant or pollutant property	Maximum for any one day	Maximum for monthly average
mg/off-kg (lb/million off-lbs) of titanium formed		
Chromium	.094	.039
Copper	.407	.214
*Cyanide	.062	.026
*Lead	.090	.043
Nickel	.411	.272
*Zinc	.313	.131
*Ammonia	28.500	12.600
*Fluoride	12.800	5.650
Titanium	.201	.088

Table XII-29

URANIUM FORMING SUBCATEGORY
 PRETREATMENT STANDARDS FOR NEW SOURCES

PSNS
 Uranium
 Extrusion Spent Lubricants

There shall be no discharge of process wastewater pollutants.

PSNS
 Uranium
 Extrusion Tool Contact Cooling Water

Pollutant or pollutant property	Maximum for any one day	Maximum for monthly average
mg/off-kg (lb/million off-lbs) of uranium extruded		
*Cadmium	.007	.003
*Chromium	.013	.005
*Copper	.044	.021
*Lead	.010	.004
*Nickel	.019	.013
Zinc	.035	.015
*Fluoride	2.050	.908
*Molybdenum	.173	.077
Uranium	.148	.108

PSNS
 Uranium
 Forging Spent Lubricants

There shall be no discharge of process wastewater pollutants.

Table XII-29 (Continued)

URANIUM FORMING SUBCATEGORY
PRETREATMENT STANDARDS FOR NEW SOURCES

PSNS

Uranium

Heat Treatment Contact Cooling Water

Pollutant or pollutant property	Maximum for any one day	Maximum for monthly average
mg/off-kg (lb/million off-lbs) of extruded or forged uranium heat treated		
*Cadmium	.006	.003
*Chromium	.012	.005
*Copper	.040	.019
*Lead	.009	.004
*Nickel	.017	.012
Zinc	.032	.013
*Fluoride	1.860	.827
*Molybdenum	.158	.070
Uranium	.134	.098

PSNS

Uranium

Surface Treatment Spent Baths

Pollutant or pollutant property	Maximum for any one day	Maximum for monthly average
mg/off-kg (lb/million off-lbs) of uranium surface treated		
*Cadmium	.005	.002
*Chromium	.010	.004
*Copper	.035	.017
*Lead	.008	.004
*Nickel	.015	.010
Zinc	.028	.011
*Fluoride	1.620	.718
*Molybdenum	.137	.061
Uranium	.117	.085

Table XII-29 (Continued)

URANIUM FORMING SUBCATEGORY
PRETREATMENT STANDARDS FOR NEW SOURCES

PSNS

Uranium

Surface Treatment Rinse

Pollutant or pollutant property	Maximum for any one day	Maximum for monthly average
mg/off-kg (lb/million off-lbs) of uranium surface treated		
*Cadmium	.067	.027
*Chromium	.125	.051
*Copper	.432	.206
*Lead	.094	.044
*Nickel	.186	.125
Zinc	.344	.142
*Fluoride	20.100	8.900
*Molybdenum	1.700	.752
Uranium	1.450	1.050

PSNS

Uranium

Sawing or Grinding Spent Emulsions

Pollutant or pollutant property	Maximum for any one day	Maximum for monthly average
mg/off-kg (lb/million off-lbs) of uranium sawed or ground with emulsions		
*Cadmium	.0011	.0005
*Chromium	.0021	.0009
*Copper	.0073	.0035
*Lead	.0016	.0007
*Nickel	.0031	.0021
Zinc	.0058	.0024
*Fluoride	.3380	.1500
*Molybdenum	.0286	.0127
Uranium	.0244	.0178

Table XII-29 (Continued)

URANIUM FORMING SUBCATEGORY
 PRETREATMENT STANDARDS FOR NEW SOURCES

PSNS

Uranium

Sawing or Grinding Contact Cooling Water

Pollutant or pollutant property	Maximum for any one day	Maximum for monthly average
mg/off-kg (lb/million off-lbs) of uranium sawed or ground with contact cooling water		
*Cadmium	.033	.013
*Chromium	.061	.025
*Copper	.211	.101
*Lead	.046	.022
*Nickel	.091	.061
Zinc	.169	.069
*Fluoride	9.820	4.360
*Molybdenum	.830	.368
Uranium	.708	.515

PSNS

Uranium

Sawing or Grinding Rinse

Pollutant or pollutant property	Maximum for any one day	Maximum for monthly average
mg/off-kg (lb/million off-lbs) of sawed or ground uranium rinsed		
*Cadmium	.0009	.0004
*Chromium	.0017	.0007
*Copper	.0060	.0028
*Lead	.0013	.0006
*Nickel	.0026	.0017
Zinc	.0048	.0020
*Fluoride	.2770	.1230
*Molybdenum	.0234	.0104
Uranium	.0200	.0145

Table XII-29 (Continued)

URANIUM FORMING SUBCATEGORY
PRETREATMENT STANDARDS FOR NEW SOURCES

PSNS
Uranium
Area Cleaning Washwater

Pollutant or pollutant property	Maximum for any one day	Maximum for monthly average
mg/off-kg (lb/million off-lbs) of uranium formed		
*Cadmium	.009	.003
*Chromium	.016	.006
*Copper	.055	.026
*Lead	.012	.006
*Nickel	.024	.016
Zinc	.044	.018
*Fluoride	2.550	1.130
*Molybdenum	.216	.096
Uranium	.184	.134

PSNS
Uranium
Degreasing Spent Solvents

There shall be no discharge of process wastewater
pollutants.

PSNS
Uranium
Wet Air Pollution Control Blowdown

Pollutant or pollutant property	Maximum for any one day	Maximum for monthly average
mg/off-kg (lb/million off-lbs) of uranium surface treated		
*Cadmium	.0007	.0003
*Chromium	.0013	.0005
*Copper	.0045	.0021
*Lead	.0010	.0005
*Nickel	.0019	.0013
Zinc	.0036	.0015
*Fluoride	.2080	.0922
*Molybdenum	.0176	.0078
Uranium	.0150	.0109

Table XII-29 (Continued)

URANIUM FORMING SUBCATEGORY
PRETREATMENT STANDARDS FOR NEW SOURCES

PSNS
Uranium
Drum Washwater

Pollutant or pollutant property	Maximum for any one day	Maximum for monthly average
mg/off-kg (lb/million off-lbs) of uranium formed		
*Cadmium	.009	.004
*Chromium	.016	.007
*Copper	.057	.027
*Lead	.012	.006
*Nickel	.024	.016
Zinc	.045	.019
*Fluoride	2.640	1.170
*Molybdenum	.223	.099
Uranium	.190	.138

PSNS
Uranium
Laundry Washwater

Pollutant or pollutant property	Maximum for any one day	Maximum for monthly average
mg/employee-day uranium formed		
Cadmium	5.240	2.100
Chromium	9.700	3.930
Copper	33.600	16.000
Lead	7.340	3.410
Nickel	14.400	9.700
Zinc	26.700	11.000
Fluoride	1,560.000	692.000
Molybdenum	132.000	58.400
Uranium	113.000	81.800

Table XII-30

ZINC FORMING SUBCATEGORY
 PRETREATMENT STANDARDS FOR NEW SOURCES

PSNS
 Zinc Forming
 Rolling Spent Neat Oils

There shall be no discharge of process wastewater pollutants.

PSNS
 Zinc Forming
 Rolling Spent Emulsions

Pollutant or pollutant property	Maximum for any one day	Maximum for monthly average
mg/off-kg (lb/million off-lbs) of zinc rolled with emulsions		
*Chromium	.0005	.0002
*Copper	.0018	.0009
*Cyanide	.0003	.0001
Nickel	.0008	.0005
*Zinc	.0014	.0006

PSNS
 Zinc Forming
 Rolling Contact Cooling Water

Pollutant or pollutant property	Maximum for any one day	Maximum for monthly average
mg/off-kg (lb/million off-lbs) of zinc rolled with contact cooling water		
*Chromium	.020	.008
*Copper	.069	.033
*Cyanide	.011	.004
Nickel	.030	.020
*Zinc	.055	.023

Table XII-30 (Continued)

ZINC FORMING SUBCATEGORY
 PRETREATMENT STANDARDS FOR NEW SOURCES

PSNS
 Zinc Forming
 Drawing Spent Emulsions

Pollutant or pollutant property	Maximum for any one day	Maximum for monthly average
mg/off-kg (lb/million off-lbs) of zinc drawn with emulsions		
*Chromium	.0022	.0009
*Copper	.0074	.0035
*Cyanide	.0012	.0005
Nickel	.0032	.0022
*Zinc	.0059	.0024

PSNS
 Zinc Forming
 Direct Chill Casting Contact Cooling Water

Pollutant or pollutant property	Maximum for any one day	Maximum for monthly average
mg/off-kg (lb/million off-lbs) of zinc cast by the direct chill method		
*Chromium	.019	.008
*Copper	.065	.031
*Cyanide	.010	.004
Nickel	.028	.019
*Zinc	.052	.021

PSNS
 Zinc Forming
 Stationary Casting Contact Cooling Water

There shall be no discharge of process wastewater
 pollutants.

Table XII-30 (Continued)

ZINC FORMING SUBCATEGORY
 PRETREATMENT STANDARDS FOR NEW SOURCES

PSNS
 Zinc Forming
 Heat Treatment Contact Cooling Water

Pollutant or pollutant property	Maximum for any one day	Maximum for monthly average
mg/off-kg (lb/million off-lbs) of zinc heat treated		
*Chromium	.028	.012
*Copper	.098	.047
*Cyanide	.015	.006
Nickel	.042	.028
*Zinc	.078	.032

PSNS
 Zinc Forming
 Surface Treatment Spent Baths

Pollutant or pollutant property	Maximum for any one day	Maximum for monthly average
mg/off-kg (lb/million off-lbs) of zinc surface treated		
*Chromium	.033	.013
*Copper	.114	.054
*Cyanide	.018	.007
Nickel	.049	.033
*Zinc	.091	.037

Table XII-30 (Continued)

ZINC FORMING SUBCATEGORY
 PRETREATMENT STANDARDS FOR NEW SOURCES

PSNS
 Zinc Forming
 Surface Treatment Rinse

Pollutant or pollutant property	Maximum for any one day	Maximum for monthly average
mg/off-kg (lb/million off-lbs) of zinc surface treated		
*Chromium	.133	.054
*Copper	.458	.219
*Cyanide	.072	.029
Nickel	.197	.133
*Zinc	.365	.151

PSNS
 Zinc Forming
 Alkaline Cleaning Spent Baths

Pollutant or pollutant property	Maximum for any one day	Maximum for monthly average
mg/off-kg (lb/million off-lbs) of zinc alkaline cleaned		
*Chromium	.0013	.0005
*Copper	.0046	.0022
*Cyanide	.0007	.0003
Nickel	.0020	.0013
*Zinc	.0036	.0015

Table XII-30 (Continued)

ZINC FORMING SUBCATEGORY
 PRETREATMENT STANDARDS FOR NEW SOURCES

PSNS
 Zinc Forming
 Alkaline Cleaning Rinse

Pollutant or pollutant property	Maximum for any one day	Maximum for monthly average
mg/off-kg (lb/million off-lbs) of zinc alkaline cleaned		
*Chromium	.626	.254
*Copper	2.170	1.030
*Cyanide	.338	.135
Nickel	.930	.626
*Zinc	1.730	.710

PSNS
 Zinc Forming
 Sawing or Grinding Spent Emulsions

Pollutant or pollutant property	Maximum for any one day	Maximum for monthly average
mg/off-kg (lb/million off-lbs) of zinc sawed or ground with emulsions		
*Chromium	.009	.004
*Copper	.031	.015
*Cyanide	.005	.002
Nickel	.013	.009
*Zinc	.024	.010

PSNS
 Zinc Forming
 Degreasing Spent Solvents

There shall be no discharge of process wastewater
 pollutants.

Table XII-30 (Continued)

ZINC FORMING SUBCATEGORY
 PRETREATMENT STANDARDS FOR NEW SOURCES

PSNS
 Zinc Forming
 Electrocoating Rinse

Pollutant or pollutant property	Maximum for any one day	Maximum for monthly average
mg/off-kg (lb/million off-lbs) of zinc electrocoated		
*Chromium	.085	.034
*Copper	.293	.140
*Cyanide	.046	.018
Nickel	.126	.085
*Zinc	.234	.096

Table XII-31

ZIRCONIUM-HAFNIUM FORMING SUBCATEGORY
 PRETREATMENT STANDARDS FOR NEW SOURCES

PSNS
 Zirconium-Hafnium Forming
 Rolling Spent Neat Oils

There shall be no discharge of process wastewater pollutants.

PSNS
 Zirconium-Hafnium Forming
 Drawing Spent Lubricants

There shall be no discharge of process wastewater pollutants.

PSNS
 Zirconium-Hafnium Forming
 Extrusion Spent Lubricants

There shall be no discharge of process wastewater pollutants.

PSNS
 Zirconium-Hafnium Forming
 Extrusion Press Hydraulic Fluid Leakage

Pollutant or pollutant property	Maximum for any one day	Maximum for monthly average
mg/off-kg (lb/million off-lbs) of zirconium-hafnium extruded		
*Chromium	.104	.043
Copper	.451	.237
*Cyanide	.069	.029
Lead	.100	.047
*Nickel	.455	.301
Zinc	.346	.145
*Ammonia	31.600	13.900
*Fluoride	14.100	6.260
Zirconium	6.830	3.300

Table XII-31 (Continued)

ZIRCONIUM-HAFNIUM FORMING SUBCATEGORY
 PRETREATMENT STANDARDS FOR NEW SOURCES

PSNS

Zirconium-Hafnium Forming
 Swaging Spent Neat Oils

There shall be no discharge of process wastewater pollutants.

PSNS

Zirconium-Hafnium Forming
 Tube Reducing Spent Lubricants

There shall be no discharge of process wastewater pollutants.

PSNS

Zirconium-Hafnium Forming
 Heat Treatment Contact Cooling Water

Pollutant or pollutant property	Maximum for any one day	Maximum for monthly average
mg/off-kg (lb/million off-lbs) of zirconium-hafnium heat treated		
*Chromium	.015	.006
Copper	.065	.034
*Cyanide	.010	.004
Lead	.014	.007
*Nickel	.066	.044
Zinc	.050	.021
*Ammonia	4.570	2.010
*Fluoride	2.040	.906
Zirconium	.988	.477

Table XII-31 (Continued)

ZIRCONIUM-HAFNIUM FORMING SUBCATEGORY
 PRETREATMENT STANDARDS FOR NEW SOURCES

PSNS

Zirconium-Hafnium Forming
 Surface Treatment Spent Baths

Pollutant or pollutant property	Maximum for any one day	Maximum for monthly average
mg/off-kg (lb/million off-lbs) of zirconium-hafnium surface treated		
*Chromium	.150	.061
Copper	.646	.340
*Cyanide	.099	.041
Lead	.143	.068
*Nickel	.653	.432
Zinc	.497	.208
*Ammonia	45.300	19.900
*Fluoride	20.300	8.980
Zirconium	9.790	4.730

PSNS

Zirconium-Hafnium Forming
 Surface Treatment Rinse

Pollutant or pollutant property	Maximum for any one day	Maximum for monthly average
mg/off-kg (lb/million off-lbs) of zirconium-hafnium surface treated		
*Chromium	.391	.160
Copper	1.690	.888
*Cyanide	.258	.107
Lead	.373	.178
*Nickel	1.710	1.130
Zinc	1.300	.542
*Ammonia	119.000	52.100
*Fluoride	52.900	23.500
Zirconium	25.600	12.400

Table XII-31 (Continued)

ZIRCONIUM-HAFNIUM FORMING SUBCATEGORY
 PRETREATMENT STANDARDS FOR NEW SOURCES

PSNS
 Zirconium-Hafnium Forming
 Alkaline Cleaning Spent Baths

Pollutant or pollutant property	Maximum for any one day	Maximum for monthly average
mg/off-kg (lb/million off-lbs) of zirconium-hafnium alkaline cleaned		
*Chromium	.704	.288
Copper	3.040	1.600
*Cyanide	.464	.192
Lead	.672	.320
*Nickel	3.070	2.030
Zinc	2.340	.976
*Ammonia	213.000	93.800
*Fluoride	95.200	42.300
Zirconium	46.100	22.300

PSNS
 Zirconium-Hafnium Forming
 Alkaline Cleaning Rinse

Pollutant or pollutant property	Maximum for any one day	Maximum for monthly average
mg/off-kg (lb/million off-lbs) of zirconium-hafnium alkaline cleaned		
*Chromium	1.380	.565
Copper	5.970	3.140
*Cyanide	.911	.377
Lead	1.320	.628
*Nickel	6.030	3.990
Zinc	4.590	1.920
*Ammonia	419.000	184.000
*Fluoride	187.000	82.900
Zirconium	90.500	43.700

Table XII-31 (Continued)

ZIRCONIUM-HAFNIUM FORMING SUBCATEGORY
 PRETREATMENT STANDARDS FOR NEW SOURCES

PSNS
 Zirconium-Hafnium Forming
 Molten Salt Rinse

Pollutant or pollutant property	Maximum for any one day	Maximum for monthly average
mg/off-kg (lb/million off-lbs) of zirconium-hafnium treated with molten salt		
*Chromium	.333	.136
Copper	1.440	.756
*Cyanide	.219	.091
Lead	.318	.151
*Nickel	1.450	.960
Zinc	1.110	.461
*Ammonia	101.000	44.300
*Fluoride	45.000	20.000
Zirconium	21.800	10.500

PSNS
 Zirconium-Hafnium Forming
 Sawing or Grinding Spent Neat Oils

There shall be no discharge of process wastewater
 pollutants.

Table XII-31 (Continued)

ZIRCONIUM-HAFNIUM FORMING SUBCATEGORY
 PRETREATMENT STANDARDS FOR NEW SOURCES

PSNS

Zirconium-Hafnium Forming
 Sawing or Grinding Spent Emulsions

Pollutant or pollutant property	Maximum for any one day	Maximum for monthly average
mg/off-kg (lb/million off-lbs) of zirconium-hafnium sawed or ground with emulsions		
*Chromium	.124	.051
Copper	.534	.281
*Cyanide	.082	.034
Lead	.118	.056
*Nickel	.540	.357
Zinc	.410	.172
*Ammonia	37.500	16.500
*Fluoride	16.700	7.420
Zirconium	8.090	3.910

PSNS

Zirconium-Hafnium Forming
 Sawing or Grinding Contact Cooling Water

Pollutant or pollutant property	Maximum for any one day	Maximum for monthly average
mg/off-kg (lb/million off-lbs) of zirconium-hafnium sawed or ground with contact cooling water		
*Chromium	.141	.058
Copper	.610	.321
*Cyanide	.093	.039
Lead	.135	.064
*Nickel	.617	.408
Zinc	.469	.196
*Ammonia	42.800	18.800
*Fluoride	19.100	8.480
Zirconium	9.250	4.460

Table XII-31 (Continued)

ZIRCONIUM-HAFNIUM FORMING SUBCATEGORY
 PRETREATMENT STANDARDS FOR NEW SOURCES

PSNS

Zirconium-Hafnium Forming
 Sawing or Grinding Rinse

Pollutant or pollutant property	Maximum for any one day	Maximum for monthly average
mg/off-kg (lb/million off-lbs) of sawed or ground zirconium-hafnium rinsed		
*Chromium	.079	.032
Copper	.342	.180
*Cyanide	.052	.022
Lead	.076	.036
*Nickel	.346	.229
Zinc	.263	.110
*Ammonia	24.000	10.600
*Fluoride	10.700	4.750
Zirconium	5.190	2.500

PSNS

Zirconium-Hafnium Forming
 Inspection and Testing Wastewater

Pollutant or pollutant property	Maximum for any one day	Maximum for monthly average
mg/off-kg (lb/million off-lbs) of zirconium-hafnium tested		
*Chromium	.007	.003
Copper	.029	.015
*Cyanide	.004	.002
Lead	.006	.003
*Nickel	.030	.020
Zinc	.023	.009
*Ammonia	2.050	.903
*Fluoride	.917	.407
Zirconium	.444	.214

Table XII-31 (Continued)

ZIRCONIUM-HAFNIUM FORMING SUBCATEGORY
PRETREATMENT STANDARDS FOR NEW SOURCES

PSNS
Zirconium-Hafnium Forming
Degreasing Spent Solvents

There shall be no discharge of process wastewater
pollutants.

PSNS
Zirconium-Hafnium Forming
Wet Air Pollution Control Blowdown

There shall be no allowance for the discharge of process
wastewater pollutants.

PSNS
Zirconium-Hafnium Forming
Degreasing Rinse

There shall be no discharge of process wastewater
pollutants.

Table XII-32

METAL POWDERS SUBCATEGORY
 PRETREATMENT STANDARDS FOR NEW SOURCES

PSNS
 Metal Powders
 Metal Powder Production Atomization Wastewater

Pollutant or pollutant property	Maximum for any one day	Maximum for monthly average
mg/off-kg (lb/million off-lbs) of powder wet atomized		
Chromium	2.220	.907
*Copper	9.580	5.040
*Cyanide	1.460	.605
*Lead	2.120	1.010
Nickel	9.680	6.400
Zinc	7.360	3.080
Aluminum	32.400	16.100
Iron	6.050	3.080

PSNS
 Metal Powders
 Tumbling, Burnishing, or Cleaning Wastewater

Pollutant or pollutant property	Maximum for any one day	Maximum for monthly average
mg/off-kg (lb/million off-lbs) of powder metallurgy parts tumbled, burnished, or cleaned		
Chromium	.194	.079
*Copper	.836	.440
*Cyanide	.128	.053
*Lead	.185	.088
Nickel	.845	.559
Zinc	.643	.269
Aluminum	2.830	1.410
Iron	.528	.269

Table XII-32 (Continued)

METAL POWDERS SUBCATEGORY
 PRETREATMENT STANDARDS FOR NEW SOURCES

PSNS
 Metal Powders
 Sawing or Grinding Spent Neat Oils

There shall be no discharge of process wastewater pollutants.

PSNS
 Metal Powders
 Sawing or Grinding Spent Emulsions

Pollutant or pollutant property	Maximum for any one day	Maximum for monthly average
mg/off-kg (lb/million off-lbs) of powder metallurgy parts sawed or ground with emulsions		
Chromium	.008	.003
*Copper	.034	.018
*Cyanide	.005	.002
*Lead	.008	.004
Nickel	.035	.023
Zinc	.026	.011
Aluminum	.117	.058
Iron	.022	.011

PSNS
 Metal Powders
 Sawing or Grinding Contact Cooling Water

Pollutant or pollutant property	Maximum for any one day	Maximum for monthly average
mg/off-kg (lb/million off-lbs) of powder metallurgy parts sawed or ground with contact cooling water		
Chromium	.713	.292
*Copper	3.080	1.620
*Cyanide	.470	.195
*Lead	.681	.324
Nickel	3.110	2.060
Zinc	2.370	.988
Aluminum	10.400	5.190
Iron	1.950	.988

Table XII-32 (Continued)

METAL POWDERS SUBCATEGORY
 PRETREATMENT STANDARDS FOR NEW SOURCES

PSNS
 Metal Powders
 Sizing Spent Neat Oils

There shall be no discharge of process wastewater pollutants.

PSNS
 Metal Powders
 Sizing Spent Emulsions

Pollutant or pollutant property	Maximum for any one day	Maximum for monthly average
mg/off-kg (lb/million off-lbs) of powder sized		
Chromium	.006	.003
*Copper	.028	.015
*Cyanide	.004	.002
*Lead	.006	.003
Nickel	.028	.019
Zinc	.021	.009
Aluminum	.094	.047
Iron	.018	.009

PSNS
 Metal Powders
 Steam Treatment Wet Air Pollution Control Blowdown

Pollutant or pollutant property	Maximum for any one day	Maximum for monthly average
mg/off-kg (lb/million off-lbs) of powder metallurgy parts steam treated		
Chromium	.035	.014
*Copper	.151	.079
*Cyanide	.023	.010
*Lead	.033	.016
Nickel	.152	.101
Zinc	.116	.048
Aluminum	.509	.254
Iron	.095	.048

Table XII-32 (Continued)

METAL POWDERS SUBCATEGORY
 PRETREATMENT STANDARDS FOR NEW SOURCES

PSNS
 Metal Powders
 Oil-Resin Impregnation Spent Neat Oils

There shall be no discharge of process wastewater pollutants.

PSNS
 Metal Powders
 Degreasing Spent Solvents

There shall be no discharge of process wastewater pollutants.

PSNS
 Metal Powders
 Hot Pressing Contact Cooling Water

Pollutant or pollutant property	Maximum for any one day	Maximum for monthly average
mg/off-kg (lb/million off-lbs) of powder cooled after pressing		
Chromium	.387	.159
*Copper	1.670	.880
*Cyanide	.255	.106
*Lead	.370	.176
Nickel	1.690	1.120
Zinc	1.290	.537
Aluminum	5.660	2.820
Iron	1.060	.537

Table XII-32 (Continued)

METAL POWDERS SUBCATEGORY
 PRETREATMENT STANDARDS FOR NEW SOURCES

PSNS
 Metal Powders
 Mixing Wet Air Pollution Control Blowdown

Pollutant, or pollutant property	Maximum for any one day	Maximum for monthly average
mg/off-kg (lb/million off-lbs) of powder mixed		
Chromium	3.480	1.420
*Copper	15.000	7.900
*Cyanide	2.290	.948
*Lead	3.320	1.580
Nickel	15.200	10.100
Zinc	11.600	4.820
Aluminum	50.800	25.300
Iron	9.480	4.820

SECTION XIII

BEST CONVENTIONAL POLLUTANT CONTROL TECHNOLOGY

The 1977 amendments to the Clean Water Act added Section 301(b)(2)(E), establishing "best conventional pollutant control technology" (BCT) for discharge of conventional pollutants from existing industrial point sources. Biological oxygen-demand (BOD5), total suspended solids (TSS), fecal coliform, oil and grease (O&G), and pH are considered by EPA to be conventional pollutants (see 44 FR 50732, August 29, 1979).

BCT is not an additional limitation but replaces BAT for the control of conventional pollutants. In addition to other factors specified in Section 304(b)(4)(B), the Act requires that BCT limitations be assessed in light of a two-part "cost-reasonableness" test (American Paper Institute v. EPA, 660 F.2d 954 (4th Cir. 1981)). The first test compares the cost for private industry to reduce its conventional pollutants with the costs to publicly owned treatment works for similar levels of reduction in their discharge of these pollutants. The second test examines the cost-effectiveness of additional industrial treatment beyond BPT. EPA must find that limitations are "reasonable" under both tests before establishing them as BCT. In no case may BCT be less stringent than BPT.

EPA published its methodology for carrying out the BCT analysis on August 29, 1979 (44 FR 50732). In the case mentioned above, the Court of Appeals ordered EPA to correct data errors underlying EPA's calculation of the first test, and to apply the second cost test. (EPA argued that a second cost test was not required.) On October 29, 1982, the Agency proposed a revised BCT methodology (47 FR 49176). On September 20, 1984, EPA published a notice of availability of new data for comment (49 FR 37046). EPA is deferring issuance of BCT limitations for the nonferrous metals forming category until the revised methodology can be applied to the technologies available for the control of conventional pollutants in the nonferrous metals forming category.

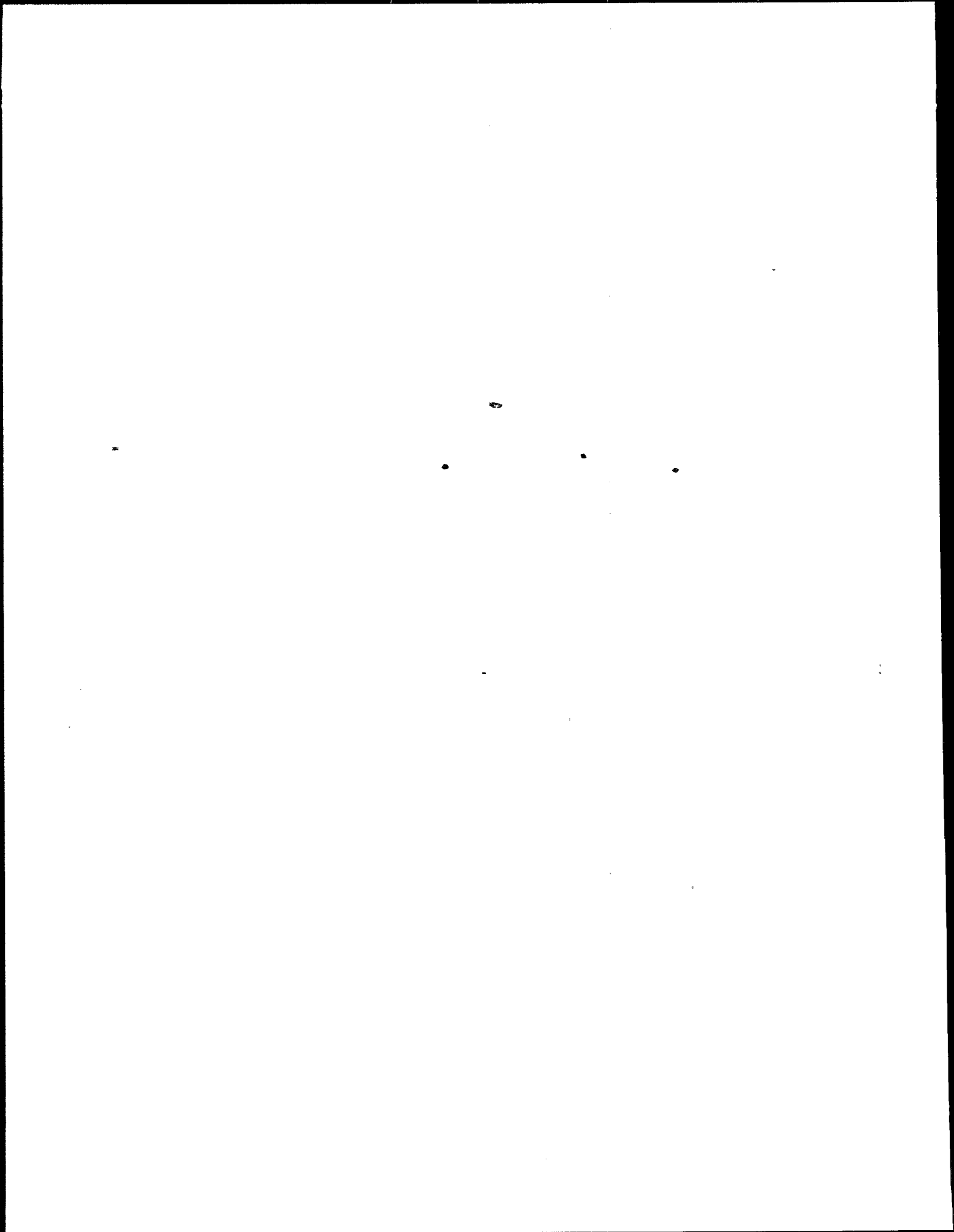

SECTION XIV

ACKNOWLEDGMENTS

The initial drafts of this document were prepared by Radian Corp. under Contract No. 68-01-6529. The document has been checked and revised at the specific direction of EPA personnel by Radian Corp. under Contract No. 68-01-6999.

The initial field sampling programs were conducted under leadership of Michael Zapkin of Radian. Some field samples were collected by Sverdrup & Parcel and Assoc. under the direction of Garry Aronberg under Contract No. 68-01-4408. Preparation and writing of the initial drafts of this document were accomplished by James Sherman, Program Manager, Mark Hereth, Project Director, Michael Zapkin, Task Leader, Marc Papai, Betsy Bicknell, Jeanne Holmes, Jill Myerson, and John Kovacic of Radian. Subsequent revisions to this document and field sampling programs after proposal were conducted under the leadership of Betsy Bicknell and Mark Hereth. Additional people who contributed in specific assignments throughout this project include Robert Eng, Matthew Phillips, Lori Stoll, Patrick Murphy, Tom Emmel, Barbara Lee, Tom Grome, John Collins, Gwen DuPoix, Carol Jamgochian, Carol Thompson, Gwen Ecklund, and Laurie Morgan.

The project was conducted by the Environmental Protection Agency, Ernst P. Hall, Chief, Metals Industries Branch. The technical project officer is Janet K. Goodwin, previous project officer was Thomas E. Fielding. The project's legal advisor is Margaret Silver, previous legal advisor who contributed to this project was Jill Weller. The economic project officer is Joseph Yance. Environmental evaluations were performed by Rod Frederick and Alexandra Tarnay with the Monitoring and Data Support Division. Statistical evaluations were performed by Henry Kahn, Barnes Johnson, Russ Roegner, and Matthew Hnatov with the Analysis and Evaluation Branch.

The cooperation and assistance of numerous individual corporations was provided during the course of this study. The numerous company and plant personnel who submitted information, cooperated with plant visits and otherwise provided information and data are acknowledged and thanked for their help.

Acknowledgment and appreciation is also given to the secretarial staffs of Radian Corporation and the Industrial Technology Division for their efforts in the typing of drafts, necessary revisions, and preparation of this effluent guidelines document.

.

.

.

.

.

.

.

.

SECTION XV

GLOSSARY

This section is an alphabetical listing of technical terms (with definitions) used in this document which may not be familiar to the reader.

4-AAP Colorimetric Method

An analytical method for total aqueous solutions to react with hydroxyl ions. Measured by titration with a standard solution of a base to a specified end point. Usually expressed as milligrams per liter of calcium carbonate.

Acidity

The quantitative capacity of aqueous solutions to react with hydroxyl ions. Measured by titration with a standard solution of a base to a specified end point. Usually expressed as milligrams per liter of calcium carbonate.

The Act

The Federal Water Pollution Control Act Amendments of 1972 as amended by the Clean Water Act of 1977 (PL 92-500).

Aging

A change in the properties of certain metals and alloys that occurs at ambient or heat treatment (quench aging in ferrous alloys, natural or artificial aging in ferrous and nonferrous alloys) or after a cold working operation (strain aging). The change in properties is often due to a phase change (precipitation), but never involves a change in chemical composition of the metal or alloy.

Alkaline Cleaning

A process in which a solution, usually detergent, is used to remove lard, oil, and other such compounds from a metal surface.

Alkalinity

The capacity of water to neutralize acids, a property imparted by the water's content of carbonates, bicarbonates, hydroxides, and occasionally borates, silicates, and phosphates. It is measured by titration with a standardized acid to a specified end point, and is usually reported in milligrams per liter of calcium carbonate.

Alloy

A substance having metallic properties and being composed of two or more chemical elements of which at least one is an elemental metal.

Amortization

The allocation of a cost or account according to a specified schedule, based on the principal, interest and period of cost allocation.

Analytical Quantification Level

The minimum concentration at which quantification of a specified pollutant can be reliably measured.

Annealing

A generic term describing a metal's treatment process that is used primarily to soften metallic materials, but also to simultaneously produce desired changes in other properties or in microstructure. The purpose of such changes may be, but is not confined to, improvement of machinability, facilitation of cold work, improvement of mechanical or electrical properties, and increase in stability of dimensions. Annealing consists of heating and cooling the metal at varying rates to achieve the desired properties.

Anvil

In drop forging, the base of the hammer into which the sower block and lower die part are set. Also, a block of steel upon which metal is forged.

Atomization

The process in which a stream of water or gas impinges upon a molten metal stream, breaking it into droplets which solidify as powder particles.

Backwashing

The operation of cleaning a filter or column by reversing the flow of liquid through it and washing out matter previously trapped.

Ball Mill

A mill in which materials are finely ground on a rotating cylinder containing balls (usually steel).

Batch Treatment

A waste treatment method where wastewater is collected over a period of time and then treated prior to discharge. Treatment is not continuous, but collection may be continuous.

Bench Scale Pilot Studies

Experiments providing data concerning the treatability of a wastewater stream or the efficiency of a treatment process conducted using laboratory-size equipment.

Best Available Demonstrated Technology (BADT)

Treatment technology upon which new source performance standards are based as defined by Section 306 of the Act.

Best Available Technology Economically Achievable (BAT)

Level of technology applicable to toxic and nonconventional pollutants on which effluent limitations are established. These limitations are to be achieved by July 1, 1984 by industrial discharges to surface waters as defined by Section 301(b)(2)(C) of the Act.

Best Conventional Pollutant Control Technology (BCT)

Level of technology applicable to conventional pollutant effluent limitations to be achieved by July 1, 1984 for industrial discharges to surface waters as defined in Section 301(b)(2)(E) of the Act.

Best Management Practices (BMP)

Regulations intended to control the release of toxic and hazardous pollutants from plant runoff, spillage, leaks, solid waste disposal, and drainage from raw material storage.

Best Practicable Control Technology Currently Available (BPT)

Level of technology applicable to effluent limitations to have been achieved by July 1, 1977 (originally) for industrial discharges to surface waters as defined by Section 301(b)(1)(A) of the Act.

Billet

A long slender cast product used as raw material in subsequent forming operations.

Biochemical Oxygen Demand (BOD)

The quantity of oxygen used in the biochemical oxidation of organic matter under specified conditions for a specified time.

Blowdown

The minimum discharge of circulating water for the purpose of discharging dissolved solids or other contaminants contained in the water, the further buildup of which would cause concentration in amounts exceeding limits established by best engineering practice.

Boring

A machining method using single-point tools on internal surfaces of revolution.

Brazing

A process that bonds two metal pieces by heating them to a suitable temperature and by using a filler material which melts above 425°C (800°F) but below the melting point of the metal being joined. The filler material is distributed between the surfaces of the joint by capillary action.

Bright Annealing

Annealing in a protective medium to prevent discoloration of the bright surface.

Brittleness

The quality of a metal that leads to crack propagation without appreciable plastic deformation.

Burnishing

A surface finishing process in which minute surface irregularities are displaced rather than removed.

Burr

A turned-over edge on a metal piece resulting from cutting, pressing, or grinding.

Catalyst

An agent that (1) reduces the energy required for activating a chemical reaction and (2) is not consumed by that reaction.

Chelation

The formation of coordinate covalent bonds between a central metal ion and a liquid that contains two or more sites for combination with the metal ion.

Chemical Finishing

Producing a desired finish on the surface of a metallic product by immersing the workpiece in a chemical bath.

Chemical Oxygen Demand (COD)

A measure of the oxygen-consuming capacity of the organic and inorganic matter present in the water or wastewater.

Chromating

Treating a metal in a solution of hexavalent chromium compound to produce a conversion coating consisting of trivalent and hexavalent chromium compound.

Clad Metal

A composite metal containing two or more layers that have been metallurgically bonded together by roll bonding (co-rolling), solder application (or brazing) and explosion bonding.

Coining

A closed-die squeezing operation, usually performed cold, in which all surfaces of the work are confined or restrained, resulting in a well-defined imprint of the die upon the work.

Cold Working

Deforming metal plastically at a temperature lower than the recrystallization temperature of the metal, generally at room temperature.

Colloid

Suspended solids whose diameter may vary between less than one micron and 15 microns.

Compact (Briquet)

An object produced by the compression of metal powder.

Composite Samples

A series of samples collected over a period of time but combined into a single sample for analysis. The individual samples can be taken after a specified amount of time has passed (time composited), or after a specified volume of water has passed the sampling point (flow composited). The sample can be automatically collected and composited by a sampler or can be manually collected and combined.

Consent Decree (Settlement Agreement)

Agreement between EPA and various environmental groups, as instituted by the United States District Court for the district of Columbia, directing EPA to study and promulgate regulations for the toxic pollutants (NRDC, Inc. v. Train, 8 ERC 2120 (D.D.C. 1976), modified March 9, 1979, 12 ERC 1833, 1841).

Contact Water

Any water or oil that comes into direct contact with nonferrous metal during forming operations, whether the metal is raw material, intermediate product, waste product, or finished product.

Continuous Casting

A casting process that produces sheet, rod, or other long shapes by solidifying the metal while it is being poured through an open-ended mold using little or no contact cooling water. Thus, no restrictions are placed on the length of the product and it is not necessary to stop the process to remove the cast product.

Continuous Treatment

Treatment of waste streams operating without interruption as opposed to batch treatment. Sometimes referred to as flow through treatment.

Contractor Removal (Contract Hauling)

Disposal of oils, spent solutions, or sludge by a commercial firm.

Conventional Pollutants

Constituents of wastewater as determined by Section 304(a)(4) of the Act, including but not limited to pollutants classified as biological-oxygen-demanding, oil and grease, suspended solids, fecal coliforms, and pH.

Conversion Coating

A coating consisting of a compound of the surface metal, produced by chemical or electrochemical treatments of the metal. Examples are chromate coatings on zinc and magnesium, oxides or phosphate coatings on steel. Also, the process of producing such a coating.

Cooling Tower

A hollow, vertical structure with internal baffles designed to break up falling water so that it is cooled by upward-flowing air and the evaporation of water.

Corrosion

The deterioration of a metal by chemical or electrochemical reaction with its environment.

Countercurrent Cascade Rinsing

A staged process that employs recycled, often untreated water as a rinsing medium to clean metal products. Water flow is opposite to product flow such that the most contaminated water encounters incoming product first.

Crucible

A vessel or pot made of a material with a high melting point used for melting metals.

Data Collection Portfolio (dcp)

The questionnaire used in the survey of the nonferrous metals forming industry.

Deoxidizing

The removal of any oxide film from a metal.

Desmutting

A process that removes smut by immersing the product in an acid solution, usually nitric acid.

Die

Various tools used to impart shape to metal primarily because of the shape of the die itself. Examples are forging dies, drawing dies, and extrusion dies.

Direct Chill Casting

A method of casting where the molten metal is poured into a water-cooled mold. The base of this mold is the top of a hydraulic cylinder that lowers the metal first through the mold and then through a water spray and bath to cause solidification. The vertical distance of the drop limits the length of the ingot. This process is also known as semi-continuous casting.

Direct Discharger

Any point source that discharges to a surface water.

Drag-out

The solution that adheres to the objects removed from a bath or rinse, more precisely defined as that solution which is carried past the edge of the tank.

Drawing

Pulling the metal through a die or succession of dies to reduce the metal's diameter or after its shape.

Drying Beds

Areas for dewatering of sludge by evaporation and seepage.

Ductility

The ability of a metal to deform plastically without fracturing.

Dummy Block

In extrusion, a thick unattached disk placed between the ram and billet to prevent overheating of the ram.

Effluent

Discharge from a point source.

Effluent Limitation

Any standard (including schedules of compliance) established by a state or EPA on quantities, rates, and concentrations of chemical, physical, biological, and other constituents that are discharged from point sources into navigable waters, the waters of the contiguous zone, or the ocean.

Electrochemical Finishing

Producing a desired finish on the surface of a metallic product by immersing the workpiece in an electrolyte bath through which direct current is passed.

Electroplating

The production of a thin coating of one metal on another by electrodeposition.

Electrostatic Precipitator (ESP)

A gas cleaning device that induces an electrical charge on a solid particle which is then attracted to an oppositely charged collector plate. The collector plates are intermittently vibrated to discharge the collector dust to a hopper.

Emulsifying Agency

A material that increase the stability of a dispersion of one liquid in another.

Emulsions

Stable dispersions of two immiscible liquids. In the nonferrous metals forming category this is usually an oil and water mixture.

End-of-Pipe Treatment

The reduction of pollutants by wastewater treatment prior to discharge or reuse.

Etching

The removal of surface imperfections, oxides, and scratches by chemical action. Etching can also provide surface roughness.

Eutectic Temperature

The lowest temperature at which a solution (in this case, the solution is molten metal and various alloying materials) remains completely liquid.

Extrusion

A process in which high pressures are applied to a metal billet, forcing the metal to flow through a die orifice.

Finishing

The coating or polishing of a metal surface.

Fluxes

Substances added to molten metal to help remove impurities and prevent excessive oxidation, or promote the fusing of the metals.

Forging

Deforming metal, usually hot, with compressive force into desired shapes, with or without dies. Where dies are used, the metal is forced to take the shape of the die.

Gas Chromatography/Mass Spectroscopy (GC/MS)

Chemical analytical instrumentation used for quantitative organic analysis.

Grab Sample

A single sample of wastewater taken without regard to time or flow.

Grain

An individual crystal in a polycrystalline metal or alloy.

Green Compact

An unsintered compact.

Grinding

The process of removing stock from a workpiece by the use of a tool consisting of abrasive grains held by a rigid or semi-rigid binder. Grinding includes surface finishing, sanding, and slicing.

Hammer Forging

Forging in which the workpiece is deformed by repeated blows.

Hardness

Resistance of metal to plastic deformation by indentation, scratching, abrasion or cutting.

Heat Treatment

A process that changes the physical properties of the metal, such as strength, ductility, and malleability by controlling the rate of cooling.

Homogenizing

Holding solidified metal at high temperature to eliminate or decrease chemical segregation by diffusion.

Hot Working

Deforming metal plastically at such a temperature and rate that strain hardening does not occur. The low limit of temperature is the recrystallization temperature of the metal.

Hydraulic Press

A press in which fluid pressure is used to actuate and control the ram.

Impacting

Forming, usually cold, a part from a metal slug confined in a die, by rapid single-stroke application of force through a punch, causing the metal to flow around the punch.

Indirect Discharger

Any point source that discharges to a publicly owned treatment works.

Inductively-Coupled Argon Plasma Spectrophotometer (ICAP)

A laboratory device used for the analysis of metals.

Ingot

A large, block-shaped casting produced by various methods. Ingots are intermediate products from which other products are made.

In-Process Control Technology

Any procedure or equipment used to conserve chemicals and water throughout the production operations, resulting in a reduction of the wastewater volume.

Jet

A stream of fluid (gas or liquid) discharged from a narrow opening or nozzle.

Mandrel

A rod used to retain the cavity in hollow metal products during working.

Metal Powder Production

Any process operations which convert metal to a finely divided form without an increase in metal purity.

Neat Oil

A pure oil with no or few impurities added. In nonferrous metals forming its use is mostly as a lubricant.

New Source Performance Standards (NSPS)

Effluent limitations for new industrial point sources as defined by Section 306 of the Act.

Nonconventional Pollutant

Parameters selected for use in performance standards that have not been previously designated as either conventional or toxic pollutants.

Nonferrous Metal

Any pure metal other than iron, copper or aluminum; or metal alloy for which a metal other than iron, copper, and aluminum is its major constituent in percent by weight.

Nonferrous Metals Forming

A set of manufacturing operations in which nonferrous metals and nonferrous alloys are made into semifinished products by hot or cold working. It also includes metal powder production and powder metallurgy of all metals, including iron, copper, and aluminum.

Non-Water Quality Environmental Impact

The ecological impact as a result of solid, air, or thermal pollution due to the application of various wastewater technologies to achieve the effluent guidelines limitations. Also associated with the non-water quality aspect is the energy impact of wastewater treatment.

NPDES Permits

Permits used by EPA or an approved state program under the National Pollutant Discharge Elimination System.

Off-Gases

Gases, vapors, and fumes produced as a result of a nonferrous metals forming operation.

Off-Kilogram (Off-Pound)

The mass of nonferrous metal or metal alloy removed from a forming operation or associated surface or heat treatment operation at the end of a process cycle for transfer to a different process or machine. For example, one kilogram for all pounds of metal that is cold rolled twice in succession on the same or tandem rolling mill and then annealed represents one off-kilogram for all pounds for cold rolling and one off-kilogram for all pounds for annealing; one off-kilogram for all pounds of metal that is cold rolled once then annealed and cold rolled again represents two off-kilograms for all pounds for cold rolling and one off-kilogram for all pounds for annealing. Product storage is also a factor in calculating off-kilograms for all pounds: one off-kilogram for all pounds of metal that is cold rolled, taken off the line and stored, then cold rolled at a later date represents two off-kilograms for all pounds for cold rolling.

Oil and Grease (O&G)

Any material that is extracted by freon from an acidified sample and that is not volatilized during the analysis, such as hydrocarbons, fatty acids, soaps, fats, waxes, and oils.

Oxidation

A reaction in which there is an increase in valence resulting from a loss of electrons.

pH

The pH is the negative logarithm of the hydrogen ion activity of a solution.

Phosphating

Forming an adherent phosphate coating on a metal immersed in a suitable aqueous phosphate solution.

Pickle Liquor

A spent acid-pickling bath.

Pickling

Removing oxides from metals by chemical or electrochemical reactions.

Pig

A metal casting used in remelting.

Plate

A flat, extended, rigid metal body having a thickness greater than or equal to 6.3 mm (0.25 inches).

Pointing

Reducing the diameter of wire, rod, or tubing over a short length by swaging, hammer forging or squeezing to facilitate entry into a drawing die and gripping in the drawhead.

Pollutant Parameters

Those constituents of wastewater determined to be detrimental and, therefore, requiring control.

Powder

Particles of mater characterized by small size, i.e., 0.1 to 1,000 um.

Powder Metallurgy

The art of producing metal powders and using metal powders for the production of massive materials (ingots, billets) and shaped objects (parts).

Press Forging

Forging metal, usually hot, between dies in a press.

Pressing

In powder metallurgy, forming a powder-metal part with compressive force.

Priority Pollutants

Those pollutants included in Table 2 of Committee Print number 95-30 of the "Committee on Public Works and Transportation of the House of Representatives," subject to the Act.

Process Water

Water used in a production process that contacts the product, raw materials, or reagents.

Production Normalized Water Discharge

The volume of water discharged from a given process per mass of nonferrous metal processed. The water may be discharged to further treatment, discharged without treatment, or removed by a contractor. Differences between the water use and wastewater flows associated with a given stream result from recycle, evaporation, and carryover on the product.

Production Normalized Water Use

The volume of water or other fluid (e.g., emulsions, lubricants) required per mass of metal processed through the operation. Water use is based on the sum of recycle and make-up flows to a given process.

Production Normalizing Parameter (PNP)

The unit of production specified in the regulations used to determine the mass of pollutants that a production facility may discharge.

PSES

Pretreatment standards (effluent regulations) for existing sources, under Section 307(b) of the Act.

PSNS

Pretreatment standards (effluent regulations) for new sources, under Section 307(c) of the Act.

Publicly Owned Treatment Works (POTW)

A waste treatment facility that is owned by a state or municipality.

Quenching

Rapid cooling, in air, vapor or water.

Ram

The moving part of a hammer or press to which a tool is fastened.

Recrystallization Temperature

The minimum temperature at which a new, strain-free grain structure is formed from that existing in a cold worked metal.

Recycle

Returning treated or untreated wastewater to the production process from which it originated for use as process water.

Reduction

A reaction in which there is a decrease in valence resulting from a gain in electrons.

Repressing

The application of pressure to a previously pressed and sintered compact, usually to improve some physical property.

Reuse

The use of treated or untreated process wastewater in a different production process.

Ring Rolling

A forging process used to shape weldless rings from pierced disks or thick-walled, ring-shaped blanks. The rings are forged between rolls or a mandrel and hammer.

Rinsing

A process in which water is used to wash surface treatment and cleaning chemicals from the surface of metal.

Rod

An intermediate metal product having a solid, round cross section 9.5 mm (3/8 inches) or more in diameter.

Roll Bonding

The process by which a permanent bond is created between two metals by rolling under high pressure in a bonding mill (co-rolling).

Rolling

A forming process that reduces the thickness of a workpiece by passing it between a pair of lubricated steel rollers.

Sand Blasting

Abrasive blasting with sand.

Sawing

Cutting a workpiece with a band, blade, or circular disk having teeth.

Scale

A thick layer of oxidation products formed on metals at high temperatures. Also deposits of water-insoluble constituents formed on surfaces in cooling towers and wet air pollution control equipment.

Scrubber Liquor

The untreated wastewater stream produced by wet scrubbers cleaning gases produced by nonferrous metals forming operations.

Seal Water

A water curtain used as a barrier between the furnace atmosphere and the outside atmosphere.

Semi-Fabricated Products

Intermediate products that are the final product of one process and the raw material for a second process.

Sheet

A flat-rolled metal product thinner than plate.

Shot

Small spherical particles of metal, larger in diameter than powder.

Shot Casting or Shotting

The production of shot by pouring metal in finely divided streams. Solidified spherical particles formed during the descent are cooled in a tank of water.

Shot Peening

Cold working the surface of a metal by metal-shot impingement.

Sintering

The bonding of adjacent surfaces of particles in a mass of metal powders or a compact, by heating to a temperature less than the melting point of the metal.

Sizing

Final pressing of a sintered compact to produce specified dimensions and tolerances.

Skiving

Removal of a material in thin layers with a high degree of shear or slippage or both. This process is used to form a trough in a strip of base metal in preparation for producing clad inlay strip.

Soldering

A process that bonds two metal pieces by heating them to a suitable temperature and by using a filler material which melts below 425°C (800°F). The filler material is distributed between the surfaces of the joint by capillary action.

Solid Solution

A single solid homogeneous crystalline phase containing two or more chemical species.

Solution Heat Treatment

Heating an alloy to a suitable temperature, holding it at that temperature long enough to cause one or more constituents to enter into solid solution, and then cooling rapidly enough to hold these constituents in solution.

Stainless Steel

An iron-base alloy, containing chromium and sometimes nickel of manganese, which is extremely resistant to corrosion. Some alloys called stainless steel are greater than 50 percent nickel.

Stationary Casting

A process in which the molten metal is poured into molds and allowed to cool. It is often used to recycle in-house scrap.

Steam Oxidation (Bluing)

Subjecting the surface of a ferrous alloy to the action of steam at a suitable temperature, thus forming a thin blue film or oxide and improving the appearance and resistance to corrosion. This process is often used for iron and steel parts pressed from metal powders.

Steel

An iron-base alloy, containing manganese, usually carbon, and often other alloying elements.

Strain Hardening

An increase in hardness and strength caused by plastic deformation at temperatures lower than the recrystallization temperature.

Strip

A sheet of metal in which the length is many times the breadth.

Subcategorization

The process of segmentation of an industry into groups of plants for which uniform effluent limitations can be established.

Surface Treatments

Operations such as pickling, etching, phosphating, and chromating which chemically alter the metal surface.

Surface Water

Any visible stream or body of water, natural or man-made. This does not include bodies of water whose sole purpose is wastewater retention or the removal of pollutants, such as holding ponds or lagoons.

Surfactants

Surface active chemicals that tend to lower the surface tension between liquids.

Swaging

A process in which a solid point is formed at the end of a tube, rod, or bar by the repeated blows of one or more pairs of opposing dies. It is often the initial step in the drawing process.

Swarf

Metallic particles and abrasive fragments removed by a cutting or grinding tool.

Tensile Strength

The ratio of maximum load to original cross-sectional area.

Total Dissolved Solids (TDS)

Organic and inorganic molecules and ions that are in solution in the water or wastewater.

Total Organic Carbon (TOC)

A measure of the organic contaminants in a wastewater. The TOC analysis does not measure as much of the organics as the COD or BOD tests, but is much quicker than these tests.

Total Recycle

The complete reuse of a stream, with makeup water added for evaporation losses. There is no blowdown stream from a totally recycled flow and the process water is not periodically or continuously discharged.

Total Suspended Solids (TSS)

Solids in suspension in water, wastewater, or treated effluent. Also known as suspended solids.

Trepanning

A type of boring where an annular cut is made into a solid material with the coincidental formation of a plug or solid cylinder. Used to prepare billets for extrusion into tubing.

Tube Reducing

Reducing both the diameter and wall thickness of tubing with a mandrel and a pair of rolls with tapered grooves.

Tubing Blank

A sample taken by passing one gallon of distilled water through a composite sampling device before initiation of actual wastewater sampling.

Tumbling (Barrel Finishing)

An operation in which castings, forgings, or parts pressed from metal powder are rotated in a barrel with ceramic or metal slugs or abrasives to remove scale, fins, or burrs. It may be done dry or with an aqueous solution.

Turning

Removing stock from a rotating workpiece with a tool.

Ultrasonic Cleaning

Immersion cleaning aided by sound waves with frequency greater than 15 kHz that cause microagitation.

Volatile Substances

Materials that are readily vaporized at relatively low temperatures.

Wet Scrubbers

Air pollution control devices used to remove particulates and fumes from air by entraining the pollutants in a water spray.

Wire

A slender strand of metal with a diameter less than 9.5 mm (3/8 inches).

Work-Hardening

An increase in hardness and strength and a loss of ductility that occurs in the workpiece as a result of passing through cold forming or cold working operations. Also known as strain-hardening.

Zero Discharger

Any industrial or municipal facility that does not discharge wastewater.

SECTION XVI

REFERENCES

Abcor, Inc., Literature on Soluble Oil Waste Treatment Systems.

"Acrolein" Final Water Quality Criteria, PB117277, Criteria and Standards Division, Office of Water Regulations and Standards (45 FR 79318-79379, November 28, 1980).

Adin, A., Baumann, E. R., Cleasby, J. L., 1979, "The Application of Filtration Theory to Pilot-Plant Design," Journal of the American Water Works Association, January.

Alloid Colloids, Inc. brochure.

Aluminum Association, Forging and Impacts Division, Aluminum Impacts Design Manual and Application Guide, July, 1979.

American Society for Metals, 1958, Handbook Metals Engineering Processes, Metals Park, Ohio.

American Society for Metals, 1964, Heat Treating, Cleaning, and Finishing, Metals Handbook, 8th ed., Vol. 2, Metals Park, Ohio.

American Society for Metals, 1970, Forging and Casting, Metals Handbook, 8th ed., Vol. 5, Metals Park, Ohio.

American Society for Metals, 1977, Definitions of Metallurgical Terms, Metals Park, Ohio.

American Society for Metals, 1982, Surface Cleaning, Finishing and Coating, Metals Handbook, 9th ed., Vol. 5, Metals Park, Ohio.

ANDCO Environmental Processes, Inc., 1981, "Andco Chromate and Heavy Metal Removal System."

"Antimony" Final Water Quality Criteria, PB117319, Criteria and Standards Division, Office of Water Regulations and Standards (45 FR 79318-79379, November 28, 1980).

API, 1969, Manual on Disposal of Refinery Wastes: Volume on Liquid Wastes, 1st ed., American Petroleum Institute, Washington, D.C.

Argo and Wesner, 1976, "AWT Energy Needs a Prime Concern," Water and Wastes Engineering, 13:5:24.

"Arsenic" Final Water Quality Criteria, PB117327, Criteria and Standards Division, Office of Water Regulations and Standards (45 FR 79318-79379, November 28, 1980).

Avitur, Betzalel, 1968, Metal Forming; Processes and Analysis, McGraw-Hill, New York, New York.

Avitur, Betzalel, 1980, Metal Forming, Dekker, New York, New York.

Bailey, P.A., "The Treatment of Waste Emulsified Oils by Ultrafiltration," Filtration and Separation, January-February, 1977.

Banerji and O'Conner, 1977, "Designing More Energy Efficient Wastewater Treatment Plants," Civil Engineering ASCE, 47:7:76.

Bansal, I. K., 1977, "Reverse Osmosis and Ultrafiltration of Oily and Pulping Effluents," Industrial Wastes, May/June.

Barksdall, J., 1966, Titanium: Its Occurrence, Chemistry and Technology.

Barnard, J. L., Eckenfelder, W. W. Jr., 1971, Treatment Cost Relationships for Industrial Waste Treatment, Technical Report #23, Vanderbilt University.

Barron, M., Donohue, J., and Dziu, L., V. J. Ciccone Associates, Inc., "Aluminum: An Environmental and Health Effects Assessment," conducted under EPA Contract No. 68-01-6572, April 27, 1983.

Basselievre, E. B., Schwartz, M., 1976, The Treatment of Industrial Wastes, McGraw-Hill Book Co., New York, NY.

Bauer, D., 1976, "Treatment of Oily Wastes--Oil Recovery Programs," Presented at 31st Annual Purdue Industrial Waste Conference.

Beddow, John K., 1978, The Production of Metal Powders by Atomization, Heyden, Philadelphia, Pennsylvania.

"Benzene" Final Water Quality Criteria, PB117293, Criteria and Standards Division, Office of Water Regulations and Standards (45 FR 79318-79379, November 28, 1980).

"Beryllium" Final Water Quality Criteria, PB117350, Criteria and Standards Division, Office of Water Regulations and Standards (45 FR 79318-79379, November 28, 1980).

Betz Labs brochure.

Birge, W. J., J. A. Black, A. G. Westerman, and J. E. Hudson, "Aquatic Toxicity Tests on Inorganic Elements Occurring in Oil Shale", Oil Shale Symposium, EPA 600/9-80-022, June 1980.

Blazynski, T. Z., 1976, Metal Forming, Wiley, New York, New York.

Bradbury, Samuel, ed., 1979, Source Book on Powder Metallurgy, American Society for Metals, Metals Park, Ohio.

Brody, M. A., Lumpkins, R. J., 1977, "Performance of Dual Media Filters," Chemical Engineering Progress, April.

Brush Wellman Inc., Alloy Information Packet.

Bureau of Mines, 1975, Mineral Facts and Problems, United States Department of the Interior.

Bureau of Mines, Mineral Commodity Profiles, 1978, Tin.

Bureau of Mines, Mineral Commodity Profiles, 1978, Zinc.

Bureau of Mines, Mineral Commodity Profiles, 1979, Antimony.

Bureau of Mines, Mineral Commodity Profiles, 1979, Beryllium.

Bureau of Mines, Mineral Commodity Profiles, Lithium.

Bureau of Mines, Mineral Commodity Profiles, 1979, Rhenium.

Bureau of Mines, 1981, Minerals Yearbook, U. S. Department of the Interior.

Bureau of Mines, Mineral Commodity Summaries, U. S. Department of Interior, 1981, pp. 174-176.

Bureau of Mines, Mineral Commodity Profiles, 1985, Columbium.

Bureau of Mines, Mineral Commodity Profiles, 1985, Magnesium.

Bureau of Mines, Mineral Commodity Profiles, 1985, Gold.

Burns and Roe, Inc., 1978, Handbook of Wastewater Treatment Costs, Randolph, New Jersey.

Butts, Allison, 1967, Silver: Economics, Metallurgy and Use, Van Nostrand, New York, New York.

"Cadmium" Final Water Quality Criteria, PB117368, Criteria and Standards Division, Office of Water Regulations and Standards (45 FR 79318-79379, November 28, 1980).

Cairns, John Harper and P. T. Gilbert, 1967, The Technology of Heavy Non-Ferrous Metals and Alloys.

"Carbon Tetrachloride" Final Water Quality Criteria, PB117376, Criteria and Standards Division, Office of Water Regulations and Standards (45 FR 79318-79379, November 28, 1980).

Carborundum, 1977, "Dissolved Air Flotation Systems," December.

Catalytic, Inc., 1979, Treatment Catalogue for the Catalytic Computer Model.

Chappell, Willard R. and Others, 1979, Human Health Effects on Molybdenum in Drinking Water. Cincinnati, Office of Research and Development, U. S. Environmental Protection Agency available from NTIS. p. 101.

Chemical Engineering, 1979, "Love Canal Aftermath: Learning from a Tragedy," Chemical Engineering, October 22.

Chemical Marketing Reporter, March 17, 1978.

Cheremisinoff, P. N., Ellerbusch, F., 1978, Carbon Adsorption Handbook, Ann Arbor Science, Ann Arbor, MI.

Chieu, J. H., Gloyna, E. F., Schechter, R. S., 1975, "Coalescence of Emulsified Oily Wastewater by Fibrous Beds," Presented at the 30th Annual Purdue Industrial Waste Conference.

"Chlorobenzene" Final Water Quality Criteria, PB117392, Criteria and Standards Division, Office of Water Regulations and Standards (45 FR 79318-79379, November 28, 1980).

"Chromium" Final Water Quality Criteria, PB117467, Criteria and Standards Division, Office of Water Regulations and Standards (45 FR 79318-79379, November 28, 1980).

Church, Fred L., "Zinc Sheet: Ample Capacity, Stable Price, Markets Needed," Modern Metals, November, 1980.

Clark, J. W., Viessman, W., Hammer, M. S., 1977, Water Supply and Pollution Control, IEP-A Dun-Donnelley Publisher, New York, NY.

Conard, B. R., E. A. Devuyt and V. A. Ettel, 1982, "Pilot Plant Operation of the INCO SO₂/Air Cyanide Removal Process," Canadian Mining Journal, August 1982.

Conard, B. R., E. A. Devuyt and W. Hudson, "Commercial-Scale Trials of the INCO SO₂/Air Cyanide Removal Process," To Be Presented at the Canada/EC Seminar Treatmnt of Complex Minerals, the Government Conference Centre, Ottawa, October 12-14, 1982.

"Copper" Final Water Quality Criteria PB117475, Criteria and Standards Division, Office of Water Regulations and Standards (45 FR 79318-79379, November 28, 1980).

Culp and Culp, 1974, New Concepts in Water Purification, Van Nostrand Reinhold, New York, NY.

Culp, R. L., Wesner, G. M., Culp, G. L., 1978, Handbook of Advanced Wastewater Treatment, Van Nostrand Reinhold Company, New York, NY.

"Cyanide" Final Water Quality Criteria, PB117483, Criteria and Standards Division, Office of Water Regulations and Standards (45 FR 79318-79379, November 28, 1980).

Davies, B. T., Vose, R. W., 1977, "Custom Designs Cut Effluent Treatment Costs, Case Histories at Chevron, U. S. A., Inc.," Purdue Industrial Waste Conference, p. 1035.

Dearborn Chemical Division brochure.

Denyo, D. J., ed., 1978, Unit Operations for Treatment of Hazardous Wastes.

"1,1-Dichloroethylene" Final Water Quality Criteria, PB117525, Criteria and Standards Division, Office of Water Regulations and Standards (45 FR 79318-79379, November 28, 1980).

Dickey, 1970, "Managing Waste Heat with the Water Cooling Tower," Marley Co.

"Dinitrotoluene" Final Water Quality Criteria, PB117566, Criteria and Standards Division, Office of Water Regulations and Standards (45 FR 79318-79379, November 28, 1980).

"Diphenylhydrazine" Final Water Quality Criteria, PB117731, Criteria and Standards Division, Office of Water Regulations and Standards (FR 79318-79379, November 28, 1980).

Dodge Building Cost Services, Dodge Guide to Public Works and Heavy Constructin Costs, McGraw-Hill, New York, New York.

Emley, Edward F., 1966, Principles of Magnesium Technology, Pergamon Press, New York, New York.

Eckenfelder, W. W. Jr., O'Connor, D. J., 1961, Biological Waste Treatment, Pergamon Press, NY.

"Endrin" Final Water Quality Criteria, PB117582, Criteria and Standards Division, Office of Water Regulations and Standards (45 FR 79418-79379, November 28, 1980).

"Endosulfan" Final Water Quality Criteria, PB117574, Criteria and Standards Division, Office of Water Regulations and Standards (45 FR 79318-79379, November 28, 1980).

Envirodyne, "Dissolved Air Flotation & Solids Settling - Model Jupiter - 7,000."

Environmental Quality Systems, Inc., 1973, Technical and Economic Review of Advanced Waste Treatment Processes.

Erbin, E. F., 1969, Applications of Titanium, ASM, Metals Engineering Institute, Metals Park, Ohio.

"Ethylbenzene" Final Water Quality Criteria PB117590, Criteria and Standards Division, Office of Water Regulations and Standards, (45 FR 79318-79379, November 28, 1980).

Federal Register, 44 FR 69464.

Federal Register, 44 FR 75028.

Federal Register, 44 FR 38749.

Federal Register, 45 FR 79318.

Federal Register, 47 FR 51512.

Federal Register, 47 FR 49176.

Federal Register, 48 FR 36942.

Federal Register, 48 FR 49126.

Federal Register, 49 FR 5831.

Floyd, D. R. and J. N. Lowe, ed., 1979, Beryllium Science and Technology, Vol. 2, Plenum Press, New York, New York.

"Fluoranthene" Final Water Quality Criteria, PB117673, Criteria and Standards Division, Office of Water Regulations and Standards (FR 79318-79379, November 28, 1980).

Ford, D. L., Elton, R. L., 1977, "Removal of Oil and Grease from Industrial Wastewaters," Chemical Engineering, October 17, p.

Forging Industries Association, 1982-1983 Forging Capability Chart, Cleveland, Ohio.

Gloyna, E. F., Ford, D. L., 1974, Cited by Osamor, F. A., Ahlert, R. C., 1978, in Oil Water Separation: State-of-the-Art, U. S. Environmental Protection Agency, Cincinnati, OH, PB-280 755.

Gumerman, R. C., R. L. Culp and S. P. Hansen, Estimating Water Treatment Costs, Volume 2, EPA-600/2-79-1620b, U. S. Environmental Protection Agency, Cincinnati, Ohio, August 1979.

Hager, D. G., 1974, "Industrial Wastewater Treatment by GAC," Industrial Water Engineering, 11:1:18.

Hammer, M. J., 1975, Water and Wastewater Technology, John Wiley & Sons, Inc., New York, NY.

Hausner, H. H., ed., 1965, Beryllium: Its Metallurgy and Properties, University of California Press, Berkeley, California.

Hawley, Gessner G., rev., The Condensed Chemical Dictionary, 9th ed.

Hawley, Gessner G., The Condensed Chemical Dictionary, 10th ed.

Hockenberry, H. R. and J. E. Lieser, "Practical Application of Membrane Techniques of Waste Oil Treatment," Journal of the American Society of Lubrication Engineers, May, 1976.

Holdway, D. A. and J. B. Sprayue, "Chronic Toxicity of Vanadium to Flagfish," Water Research, Vol. 13, 1979.

Hsiung, K. Y., Mueller, H. M., Conley, W. R., 1974, "Physical-Chemical Treatment for Oily Waste," Presented at WWEMA Industrial Water Pollution Conference and Exposition, Detroit, MI, Cited by Osamor, F. A., Ahlert, R. C., 1978 Oil/Water Separation: State-of-the-Art, U. S. Environmental Protection Agency, Cincinnati, OH, PB-280 755.

Indium Corporation of America, Product Literature.

International Magnesium Association, 1982 Buyer's Guide, Dayton, Ohio.

Jacobs Engineering Group, 1980, Draft Development Document for Effluent Limitations and Guidelines, New Source Performance Standards and Pretreatment Standards for the Metal Powders Segment of the Mechanical Products Point Source Category.

Infilco Degremont, Inc., 1974, "Sediflотор Clarifier," Company Brochure DB830, September.

"Isophorone" Final Water Quality Criteria, PB117764, Criteria and Standards Division, Office of Water Regulations and Standards (45 FR 79318-79379, November 28, 1980).

Jones, H. R., 1971, Environmental Control in the Organic and Petrochemical Industries, Noyes Data Corp., Park Ridge, NJ.

JRB Associates, Statistical Analysis Group, A Statistical Analysis of the Combined Metals Industries Effluent Data, November 4, 1982.

Katnick, K. E., Pavilcius, A. M., 1978, "A Novel Chemical Approach for the Treatment of Oily Wastewaters," Presented at 33rd Annual Purdue Industrial Waste Conference.

Keenan, Charles W. and Jesse H. Wood, 1971, General College Chemistry, 4th Edition, Harper and Row, New York.

Kennametal Inc., 1977, Properties and Proven Uses of Kennametal Hard Carbide Alloys, Latrobe, Pennsylvania.

Kirk-Othmer, 1983, Encyclopedia of Chemical Technology, Third Edition, Volume 23, John Wiley & Sons, Inc., New York, New York.

Kirk-Othmer, 1981, Encyclopedia of Chemical Technology, Third Edition, John Wiley & Sons, Inc., New York, New York.

Kirk-Othmer, 1978, Encyclopedia of Chemical Technology, Third Edition, "Molybdenum," Vol. 15, John Wiley & Sons, Inc., New York, New York.

Kirk-Othmer, 1963, Encyclopedia of Chemical Technology, Second Edition, Interscience Publishers, New York, New York.

Lacey, R. E., 1972, "Membrane Separation Processes," Chemical Engineering, Sept. 4.

Lange, Norbert, Adolph, 1973, Handbook of Chemistry, McGraw-Hill, New York, NY.

"Lead" Final Water Quality Criteria, PB117681, Criteria and Standards Division, Office of Water Regulations and Standards (45 FR 79318-79379, November 28, 1980).

Lead Industries Association, 1965, Lead and Zinc, New York, New York.

Lead Industries Association, 1979, Lead, New York, New York.

Lee, E. L., Schwab, R. E., 1978, "Treatment of Oily Machinery Waste," Presented at 33rd Annual Purdue Industrial Waste Conference.

Lenel, Fritz V., 1980, Powder Metallurgy: Principles and Applications, MPIF, Princeton, New Jersey.

"Lime for Water and Wastewater Treatment: Engineering Data," BIF, Providence, Ref. No. 1.21-24.

Lin, Y. G., Lawson, J. R., 1973, "Treatment of Oily and Metal Containing Wastewater," Pollution Engineering, November.

Liptak, B. G., 1974m Environmental Engineer's Handbook, Volume 1 - Water Pollution, Chilton Book Company, Radnor, Pennsylvania.

Lopez, C. X., Johnston, R., 1977, "Industrial Wastewater Recycling with Ultrafiltration and Reverse Osmosis," Presented at the 32nd Annual Purdue Industrial Waste Conference.

Lund, H. F., ed., 1971, Industrial Pollution Control Handbook, McGraw-Hill Book Co., New York, NY.

Luthy, R. G., Selleck, R. E., Galloway, 1978, "Removal of Emulsified Oil with Organic Coagulants and Dissolved Air Flotation," Journal Water Pollution Control Federation, 50:2:331.

Lustman and Kerze, 1955, The Metallurgy of Zirconium.

Manko, Howard H., 1979, Solders and Soldering, McGraw-Hill, New York, New York.

McKee, J. E. and Wolf, H. W., ed., 1963, Water Quality Criteria, 2nd ed., The Resources Agency of California, State Water Quality Control Board, Publication No. 3-A.

"Mercury" Final Water Quality Criteria, PB117699, Criteria and Standards Division, Office of Water Regulations and Standards (45 FR 79318-79379, November 28, 1980).

Metal Progress, "Trends in Nonferrous Metals Technology," January, 1983.

Metal Progress, "Trends in Powder Metallurgy Technology," January, 1983.

Metal Progress, "Trends in Special-Duty Materials Technology," January, 1983.

Metal Progress, "Trends in Superalloy Technology," January, 1983.

Metcalf & Eddy, Inc., 1979, Wastewater Engineering: Treatment, Disposal, Reuse, McGraw-Hill, New York, New York.

Molybdenum in the Environment: Proceedings of an International Symposium on Molybdenum in the Environment Held in Denver, Colorado / edited by Willard R. Chappell and Kathy Kellogg Petersen, New York, M. Dekker, c1976-1977. v. (xii, 812 p.): ill.: 24 cm.

MPIF, 1982, Powder Metallurgy Equipment Directory, 13th Edition, New Jersey.

MPIF, 1983, Members of the Metal Powder Industries Federation, Princeton, New Jersey.

Myansnikov, I. N., Butseva, L. N., Gandurina, L. B., 1979, "The Effectiveness of Flotation Treatments with Flocculants Applied to Oil Wastewaters," Presented at USEPA Treatment of Oil Containing Wastewaters, April 18 to 19, 1979, Cincinnati, OH.

"Naphthalene" Final Water Quality Criteria, PB117707, Criteria and Standards Division, Office of Water Regulations and Standards (45 FR 79318-79379, November 28, 1980).

"Nickel" Final Water Quality Criteria, PB117715, Criteria and Standards Division, Office of Water Regulations and Standards (45 FR 79318-79379, November 28, 1980).

NIOSH, 1980 Registry of Toxic Effects of Chemical Substances, U.S. Department of Health and Human Services.

Northcott, L., 1956, Metallurgy of Rarer Metals - 5: Molybdenum, Academic Press, New York, New York.

NTIS, 1974, Cost of Dissolved Air Flotation Thickening of Waste Activated Sludge at Municipal Sewage Treatment Plants, PB-226-582.

Nutt, S. G. and S. A. Zaidi, "Treatment of Cyanide-Containing Wastewaters by the Copper-Catalyzed SO₂/Air Oxidation Process," Presented at the 38th Annual Purdue Industrial Waste Conference Purdue University, West Lafayette, Indiana, May 10-12, 1983.

Osamor, F. A., Ahlert, R. C., 1978, Oily Water Separation: State-of-the-Art, U. S. Environmental Protection Agency, Cincinnati, OH, EPA-600/2-78-069.

"Pentachlorophenol" Final Water Quality Criteria, PB117764, Criteria and Standards Division, Office of Water Regulations and Standards (45 FR 79318-79379, November 28, 1980).

Perry, R. H. and C. H. Chilton, 1973, Chemical Engineer's Handbook, 5th Edition, McGraw-Hill.

Peters, M. S. and K. D. Timmerhaus, 1980, Plant Design and Economics for Chemical Engineers, Third Edition, McGraw-Hill.

"Phenol" Final Water Quality Criteria, PB117772, Criteria and Standards Division, Office of Water Regulations and Standards (45 FR 79318-79379, November 28, 1980).

"Phthalate Esters" Final Water Quality Criteria, PB117780, Criteria and Standards Division, Office of Water Regulations and Standards (45 FR 79318-79379, November 28, 1980).

"Polynuclear Aromatic Hydrocarbons" Final Water Quality Criteria, PB117806, Criteria and Standards Division, Office of Water Regulations and Standards (45 FR 79318-79379, November 28, 1980).

Radian Corporation, 1982, The Cost Digest - Cost Summaries of Selected Environmental Control Technologies (unpublished report), DCN 82-203-001-47-03, May.

Refractory Metals Association, 1980, What Are Refractory Metals... and How Do They Affect Our Lives? MPIF, Princeton, New Jersey.

Registry of Toxic Effects on Chemical Substances.

Richardsons Engineering Services, Inc., 1980, Process Plant Construction Estimating Standards, Volumes 1, 2, 3, and 4, Solana Beach, California.

Rinehart, John S. and John Pearson, 1963, Explosive Working of Metals, Pergamon Press, New York, New York.

Rizzo, J. L., Shephard, A. R., 1977a, "Treating Industrial Wastewater with Activated Carbon," Chemical Engineering, January 3, p. 95.

Rizzo, J. L., Shephard, A. R., 1977b, "Treating Industrial Wastewater with Activated Carbon," Chemical Engineering, September 3.

Roberts, K. L., Weeter, D. W., Ball, R. O., 1978, "Dissolved Air Flotation Performance," 33rd Annual Purdue Industrial Waste Conference, p. 194.

Ro, D. H., M. W. Toaz and V. S. Moxson, "The Direct Powder Rolling Process for Producing Thin Metal Strip," Journal of Metals, January, 1983.

Ronson Metals Corporation, Product Literature.

Russel, J. B., General Chemistry, McGraw-Hill, 1980.

Sabadell, J. E., ed., 1973, Traces of Heavy Metals in Water Removal Processes and Monitoring, USEPA, 902/9-74-001.

Schemel, J. H., 1977, ASTM Manual on Zirconium and Hafnium, ASTM Special Technical Publication 639.

Seiden and Patel, Mathematical Model of Tertiary Treatment by Lime Addition, TWRC-14.

"Selenium" Final Water Quality Criteria, PB117814, Criteria and Standards Division, Office of Water Regulations and Standards (45 FR 79318-79379, November 28, 1980).

"Silver" Final Water Quality Criteria, PB117822, Criteria and Standards Division, Office of Water Regulations and Standards (45 FR 79318-79379, November 28, 1980).

Technical Materials Inc., 1976, Handbook for Clad Metals, Lincoln, Rhode Island.

Thomas Register of American Manufacturers and Thomas Register Catalog File, 1982, Torrington, Connecticut.

Timet, Titanium.

"Toluene" Final Water Quality Criteria, PB117855, Criteria and Standards Division, Office of Water Regulations and Standards (45 FR 79318-79379, November 28, 1980).

Toxicology Data Bank.

"2,4,6-Trichlorophenol" Final Water Quality Criteria, PB117525, Criteria and Standards Division, Office of Water Regulations and Standards (45 FR 79318-79379, November 28, 1980).

"Trichloroethylene" Final Water Quality Criteria, PB117871, Criteria and Standards Division, Office of Water Regulations and Standards (45 FR 79318-79379, November 28, 1980).

"Tetrachloroethylene" Final Water Quality Criteria, PB117830, Criteria and Standards Division, Office of Water Regulations and Standards (45 FR 79318-79379, November 28, 1980).

U. S. Environmental Protection Agency, 1978h, Revised Economic Impact Analysis of Proposed Regulations on Organic Contamination Drinking Water, Office of Drinking Water.

U. S. Environmental Protection Agency, 1975, Process Design Manual for Suspended Solids Removal, EPA 625/1-75-003-a, Technology Transfer Series, January.

U. S. Environmental Protection Agency, 1977, Sampling and Analysis Procedures for Screening of Industrial Effluents for Priority Pollutants, April.

U. S. Environmental Protection Agency, 1977, Sources and Treatment of Wastewater in the Nonferrous Metals Industry, Radian Corporation, February.

U. S. Environmental Protection Agency, 1979, Methods for Chemical Analysis for Water and Wastes, EPA-600/4-79-020, March, 1979.

U. S. Environmental Protection Agency, 1980, Treatability Manual, Volume IV. Cost Estimating, EPA 600/8-80/042-d, July.

U. S. Environmental Protection Agency, 1982, Determining National Removal Credits for Selected Pollutants for Publicly Owned Treatment Works, EPA 440/2-82/008, September.

U. S. Environmental Protection Agency, 1982, Development Document for Proposed Effluent Limitations Guidelines and Standards for the Aluminum Forming Point Source Category, EPA 440/1-82/073-b, November.

U. S. Environmental Protection Agency, 1982, Development Document for Proposed Effluent Limitations Guidelines and Standards for the Copper Forming Point Source Category, EPA 449/1-82/074-b, October.

U. S. Environmental Protection Agency, 1982, Development Document for Effluent Limitations Guidelines and Standards for the Inorganic Chemicals Manufacturing Point Source Category, EPA 440/1-82/007, June.

U. S. Environmental Protection Agency, 1982, Development Document for Effluent Limitations Guidelines and Standards for the Iron and Steel Manufacturing Point Source Category, EPA 440/1-82/024, May.

U. S. Environmental Protection Agency, 1982, Development Document for Proposed Effluent Limitations Guidelines and Standards for the Metal Finishing Point Source Category, EPA 440/1-82/091-b.

U. S. Environmental Protection Agency, 1982, Fate of Priority Pollutants in Publicly Owned Treatment Works, Final Report, EPA 440/1-82/303, September.

U. S. Environmental Protection Agency, 1982, Handbook for Sampling and Sample Preservation of Water and Wastewater, EPA 600/4-82/029, September.

U. S. Environmental Protection Agency, 1983, Development Document for Proposed Effluent Limitations Guidelines and Standards for the Nonferrous Metals Point Source Category, Volume 1, EPA 440/1-83/019b, March.

U. S. Environmental Protection Agency, 1983, Development Document for Proposed Effluent Limitations Guidelines and Standards for the Inorganic Chemicals Point Source Category, Phase II, EPA 440/1-83/007-b, September.

U. S. Environmental Protection Agency, 1984, Economic Analysis of Proposed Effluent Limitations and Standards for the Nonferrous Metals Forming Industry, EPA 440/2-84/005, February.

U. S. Steel, 1971, The Making and Shaping of Steel, 9th Edition, Herbick and Held, Pittsburgh, Pennsylvania.

V. J. Ciccone & Associates, Inc., Aluminum: An Environmental and Health Effects Assessment, Additives Evaluation Branch, Criteria and Standards Division, U. S. EPA, April 27, 1983.

Verschueren and Karel, 1972, Handbook of Environmental Data on Organic Chemicals, Van Nostrand Reinhold Co., New York, NY.

Wahl, J. R., Hayes, T. C., Kleper, M. H., Pinto, S. D., 1979, "Ultrafiltration for Today's Oily Wastewaters: A Survey of Current Ultrafiltration Systems," Presented at 34th Annual Purdue Industrial Waste Conference.

Wallis, Claudia, "Slow, Steady, and Heartbreaking: Alzheimers Disease is a Devastating Illness of Advancing Age; TIME, July 11, 1983.

Wang, Yih, 1979, Tungsten: Metallurgy Properties and Application, Plenum Press, New York, New York.

Wilkinson, W. D., 1962, Uranium Metallurgy, Interscience.

Williams, S. C., 1965, Report on Titanium, The Ninth Industrial Metal.

Wise, Edmund M., 1964, Gold: Recovery, Properties and Applications, Van Nostrand, New York, New York.

"Zinc" Final Water Quality Criteria, PB117897, Criteria and Standards Division, Office of Water Regulations and Standards (45 FR 79318-79379, November 28, 1980).

Zinc Institute, Inc., U. S. Zinc and Cadmium Industries, Annual Review, 1981, New York, New York.

Zinc Institute, Inc., Zinc, December, 1983.