

Reducing Methane Emissions with Vapor Recovery on Storage Tanks



Lessons Learned
from Natural Gas STAR

Producers and Processors
Technology Transfer Workshop

Western Gas Resources and
EPA's Natural Gas STAR Program
Gillette, WY
May 9, 2006



Vapor Recovery Units: Agenda

- 🔥 Methane Losses
- 🔥 Methane Savings
- 🔥 Project Summary from Rockies Region
- 🔥 Is Recovery Profitable?
- 🔥 Industry Experience
- 🔥 Discussion Questions

Methane Losses from Storage Tanks

- Storage tanks are responsible for 6% of methane emissions in natural gas and oil production sector
 - 96% of tank losses occur from tanks without vapor recovery

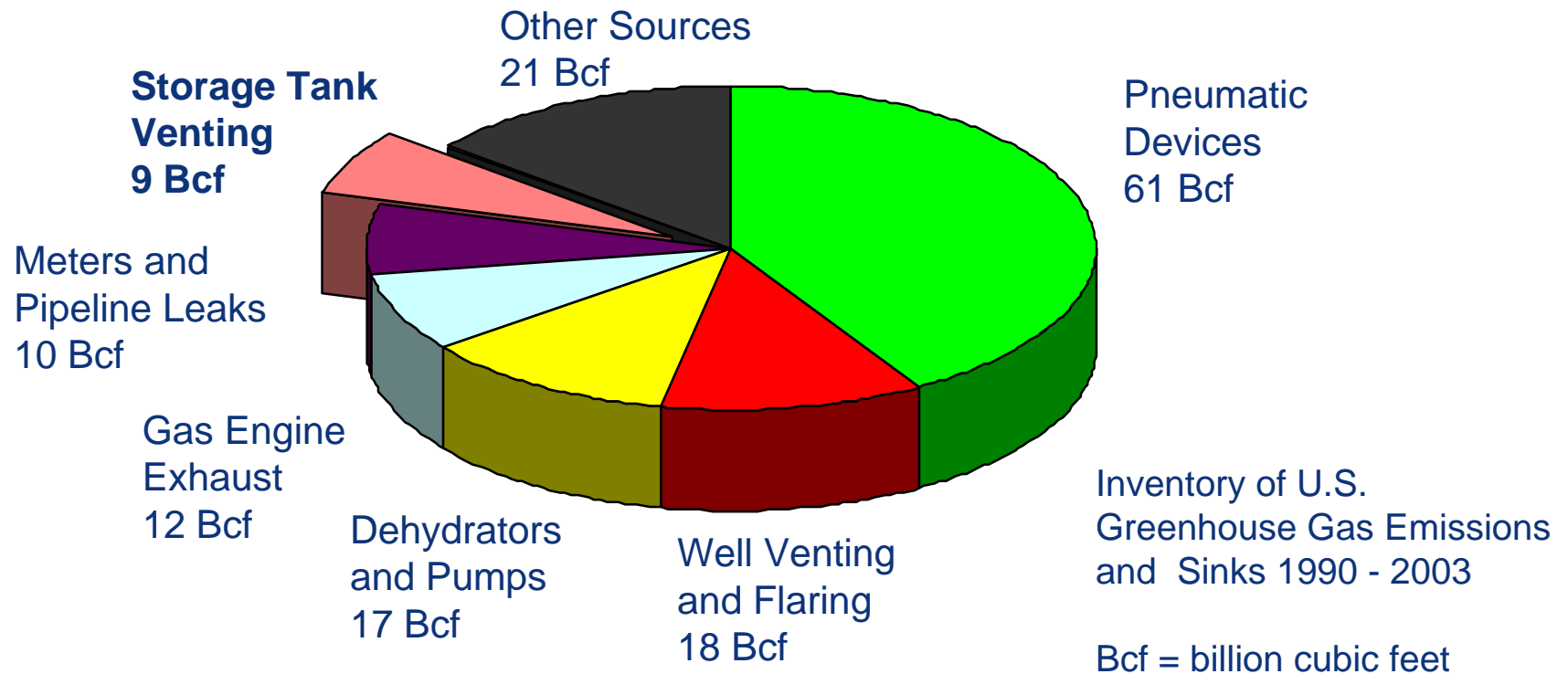

- A storage tank battery can vent 4,900 to 96,000 cubic feet (cf) of natural gas and light hydrocarbon vapors to the atmosphere each year
 - Vapor losses are primarily a function of oil throughput, gravity, and gas-oil separator pressure

Sources of Methane Losses

🔥 Flash losses

- 🔥 Occur when crude is transferred from a gas-oil separator at higher pressure to a storage tank at atmospheric pressure

🔥 Working losses

- 🔥 Occur when crude levels change and when crude in tank is agitated

🔥 Standing losses

- 🔥 Occur with daily and seasonal temperature and barometric pressure changes

Methane Savings: Vapor Recovery

- 🔥 Vapor recovery can capture up to 95% of hydrocarbon vapors from tanks
- 🔥 Recovered vapors have higher heat content than pipeline quality natural gas
- 🔥 Recovered vapors are more valuable than natural gas and have multiple uses
 - 🔥 Re-inject into sales pipeline
 - 🔥 Use as on-site fuel
 - 🔥 Send to processing plants for recovering valuable natural gas liquids

Types of Vapor Recovery Units

- 🔥 Conventional vapor recovery units (VRUs)
 - 🔥 Use rotary compressor to suck vapors out of atmospheric pressure storage tanks
 - 🔥 Require electrical power or engine driver
- 🔥 Venturi ejector vapor recovery units (EVRU™) or Vapor Jet
 - 🔥 Use Venturi jet ejectors in place of rotary compressors
 - 🔥 Contain no moving parts
 - 🔥 EVRU™ requires source of high pressure gas and intermediate pressure system
 - 🔥 Vapor Jet requires high pressure water motive

Conventional Vapor Recovery Unit

Source: Evans & Nelson (1968)

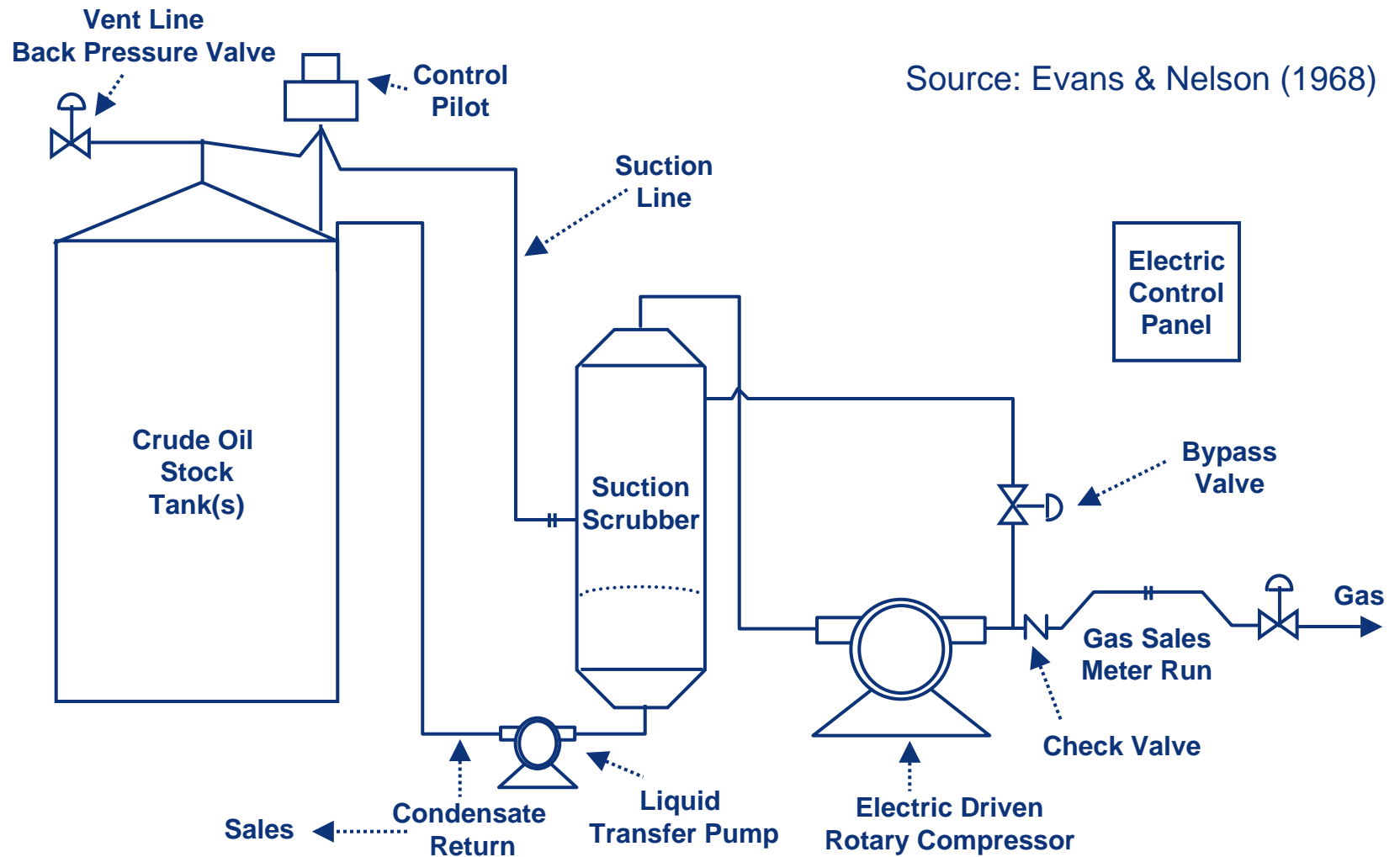

Vapor Recovery Installations



**8 Units capturing
~ 2MMSCFD**

Vapor Recovery Installations



Venturi Jet Ejector*

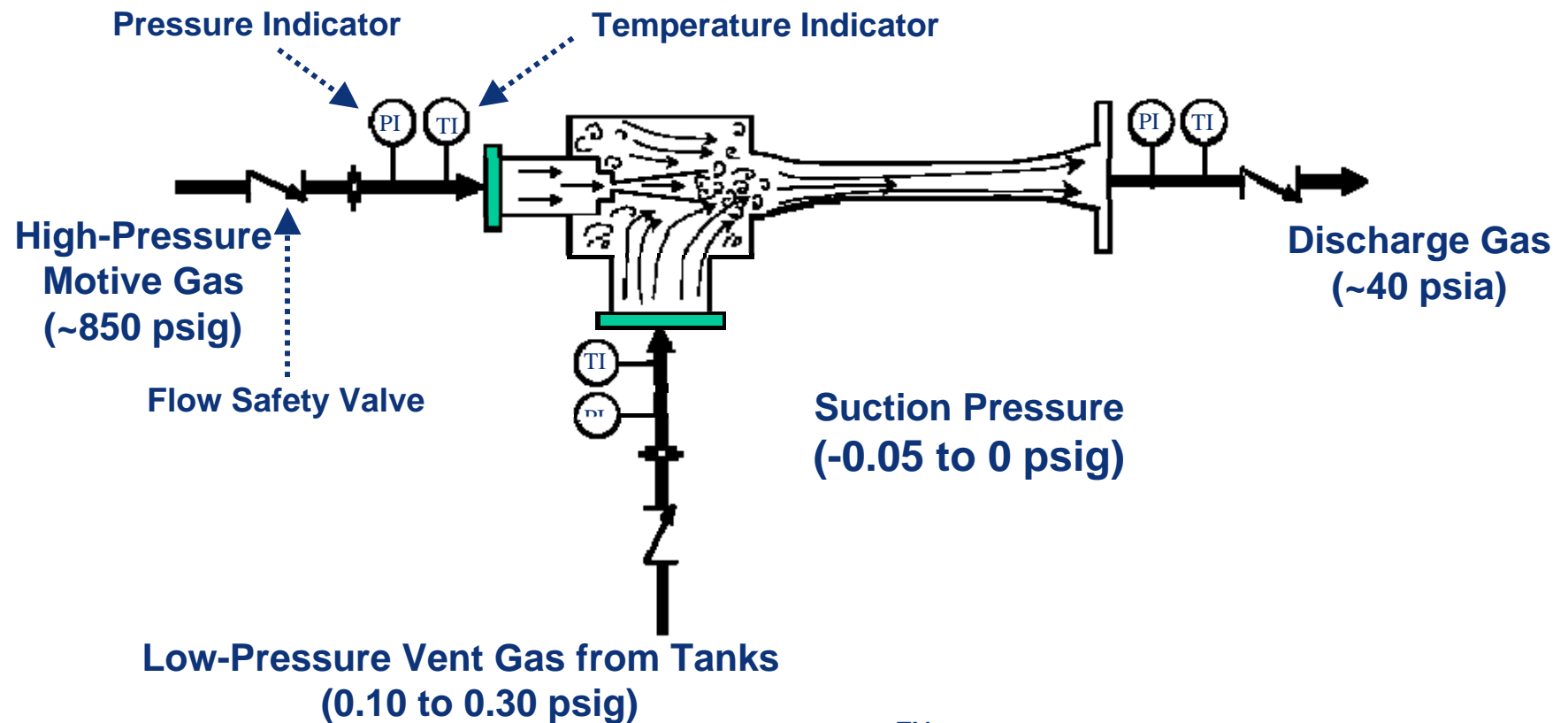

*EVRU™ Patented by COMM Engineering

Adapted from SRI/USEPA-GHG-VR-19

psig = pound per square inch, gauge

psia = pounds per square inch, atmospheric

Vapor Recovery with Ejector

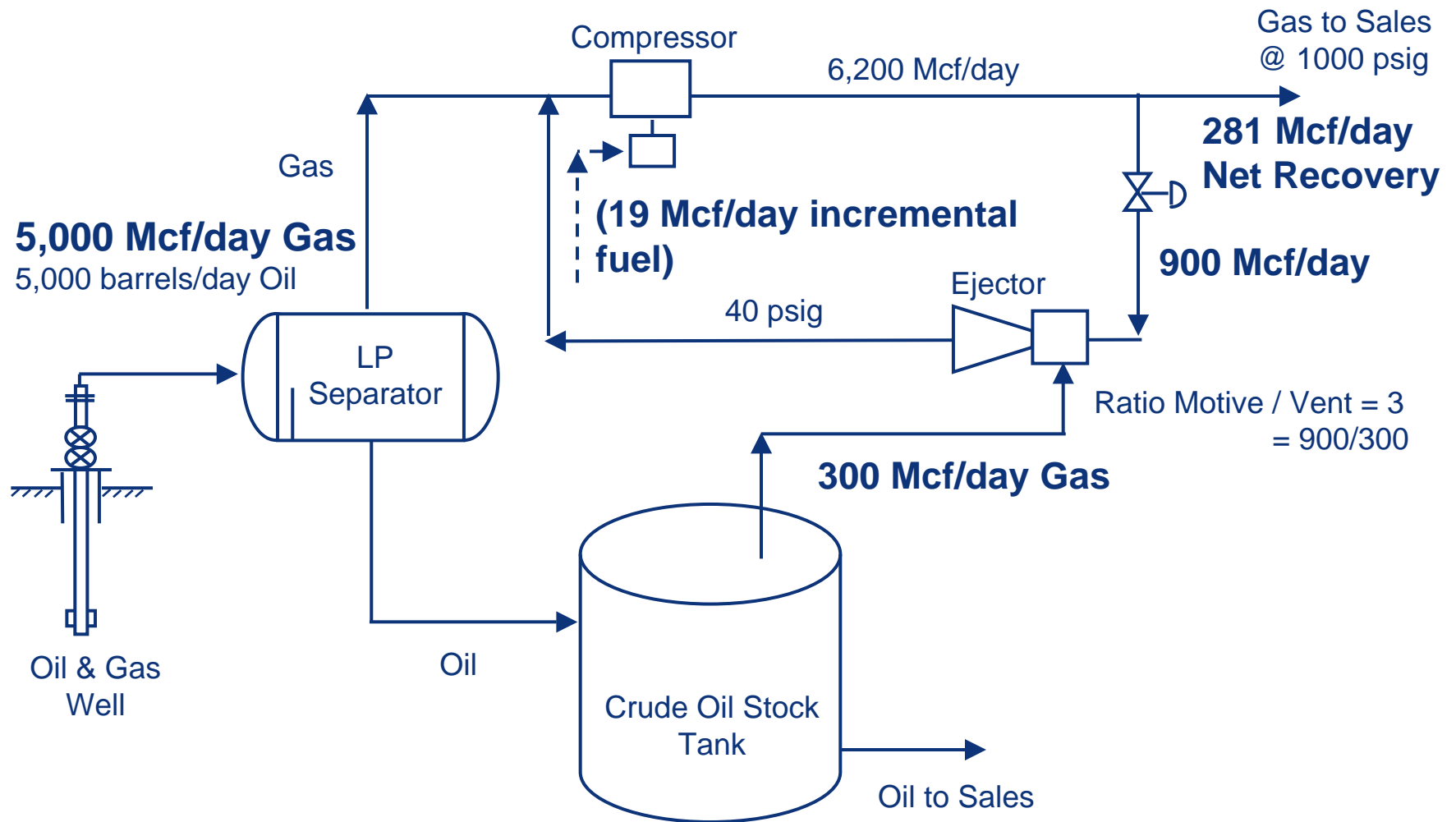

Vapor Jet System*

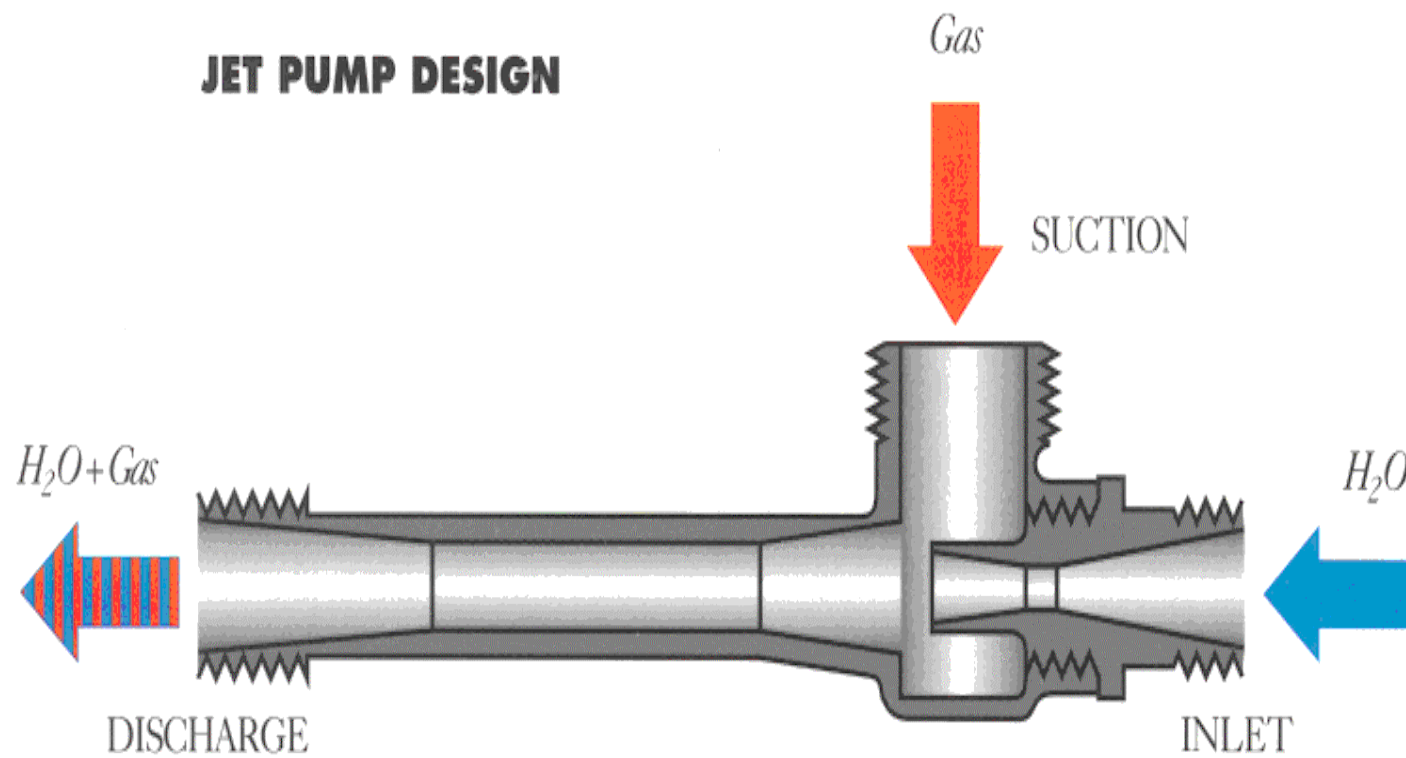

*Patented by Hy-Bon Engineering

Vapor Jet System*

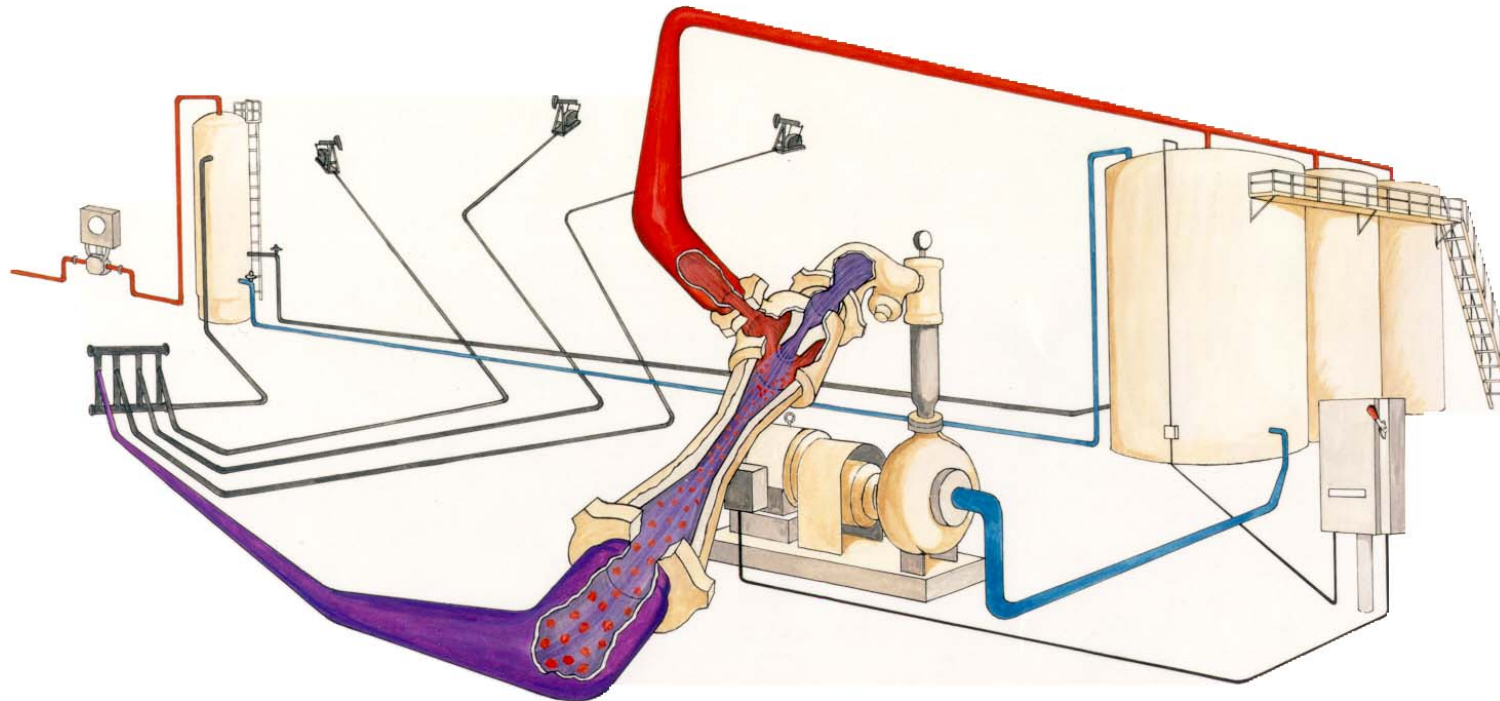

- Utilizes produced water in closed loop system to effect gas gathering from tanks
- Small centrifugal pump forces water into Venturi jet, creating vacuum effect
- Limited to gas volumes of 77 Mcf / day and discharge pressure of 40 psig

*Patented by Hy-Bon Engineering

Criteria for Vapor Recovery Unit Locations

- 🔥 Steady source and sufficient quantity of losses
 - 🔥 Crude oil stock tank
 - 🔥 Flash tank, heater/treater, water skimmer vents
 - 🔥 Gas pneumatic controllers and pumps
- 🔥 Outlet for recovered gas
 - 🔥 Access to low pressure gas pipeline, compressor suction, or on-site fuel system
- 🔥 Tank batteries not subject to air regulations

Quantify Volume of Losses

- 🔥 Estimate losses from chart based on oil characteristics, pressure, and temperature at each location ($\pm 50\%$)
- 🔥 Estimate emissions using the E&P Tank Model ($\pm 20\%$)
- 🔥 Measure losses using recording manometer and well tester or ultrasonic meter over several cycles ($\pm 5\%$)
 - 🔥 This is the best approach for facility design

Estimated Volume of Tank Vapors

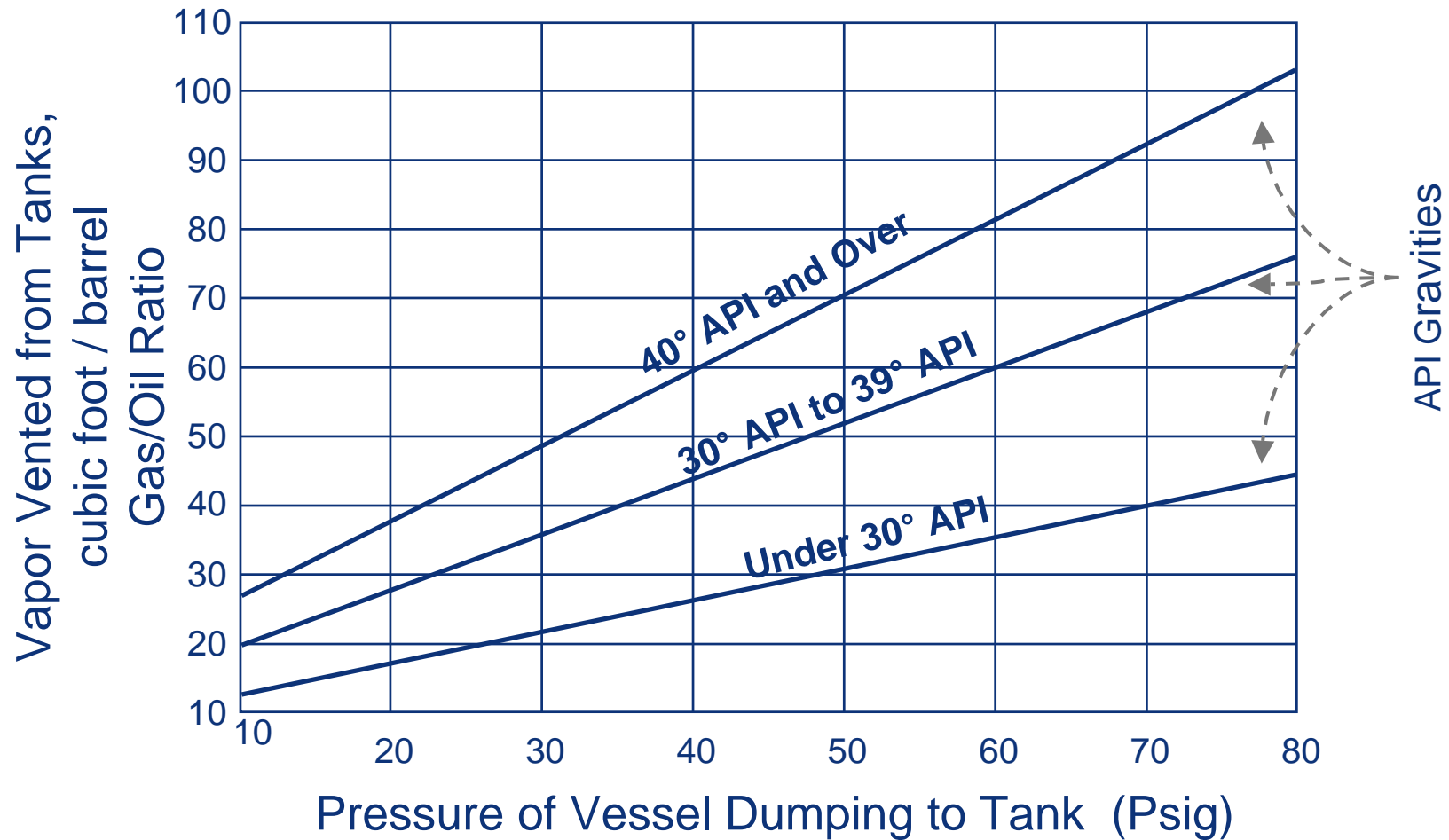

° API = API gravity

What is the Recovered Gas Worth?

- 🔥 Value depends on heat content of gas
- 🔥 Value depends on how gas is used
 - 🔥 On-site fuel
 - 🔥 Valued in terms of fuel that is replaced
 - 🔥 Natural gas pipeline
 - 🔥 Measured by the higher price for rich (higher heat content) gas
 - 🔥 Gas processing plant
 - 🔥 Measured by value of natural gas liquids and methane, which can be separated

Value of Recovered Gas

💧 Gross revenue per year = $(Q \times P \times 365) + \text{NGL}$

💧 Q = Rate of vapor recovery (Mcf per day)

💧 P = Price of natural gas

💧 NGL = Value of natural gas liquids

Value of Natural Gas Liquids

	1	2	3	4
	Btu/gallon	MMBtu/ gallon	\$/gallon	\$/MMBtu ^{1,2} (=3/2)
Methane	59,755	0.06	0.43	7.15
Ethane	74,010	0.07	0.64	9.14
Propane	91,740	0.09	0.98	10.89
n Butane	103,787	0.10	1.32	13.20
iso Butane	100,176	0.10	1.42	14.20
Pentanes+	105,000	0.11	1.50	13.63

	5	6	7	8	9	10	11
	Btu/cf	MMBtu/Mcf	\$/Mcf	\$/MMBtu	Vapor Composition	Mixture (MMBtu/Mcf)	Value (\$/Mcf) (=8*10)
	(=4*6)						
Methane	1,012	1.01	\$ 7.22	7.15	82%	0.83	\$ 5.93
Ethane	1,773	1.77	\$ 16.18	9.14	8%	0.14	\$ 1.28
Propane	2,524	2.52	\$ 27.44	10.89	4%	0.10	\$ 1.09
n Butane	3,271	3.27	\$ 43.16	13.20	3%	0.10	\$ 1.32
iso Butane	3,261	3.26	\$ 46.29	14.20	1%	0.03	\$ 0.43
Pentanes+	4,380	4.38	\$ 59.70	13.63	2%	0.09	\$ 1.23
Total						1.289	\$ 11.28

- 1 Natural Gas Price assumed at \$7.15/MMBtu as on Mar 16, 2006 at Henry Hub
 - 2 Prices of Individual NGL components are from Platts Oilgram for Mont Belvieu, TX, January 11, 2006
 - 3 Other natural gas liquids information obtained from Oil and Gas Journal, Refining Report, March 19, 2001, p-83
- Btu = British Thermal Units, MMBtu = Million British Thermal Units



Cost of a Conventional VRU

Vapor Recovery Unit Sizes and Costs				
Capacity (Mcf / day)	Compressor Horsepower	Capital Costs (\$)	Installation Costs (\$)	O&M Costs (\$ / year)
25	5-10	15,125	7,560 - 15,125	5,250
50	10-15	19,500	9,750 - 19,500	6,000
100	15 - 25	23,500	11,750 - 23,500	7,200
200	30 - 50	31,500	15,750 - 31,500	8,400
500	60 - 80	44,000	22,000 - 44,000	12,000

Cost information provided by United States Gas STAR companies and VRU manufacturers, 1998 basis.



Is Recovery Profitable?

Financial Analysis for a conventional VRU Project

Peak Capacity (Mcf / day)	Installation & Capital Costs ¹	O & M Costs (\$ / year)	Value of Gas ² (\$ / year)	Annual Savings	Simple Payback (months)	Return on Investment
25	26,470	5,250	\$ 51,465	\$ 46,215	7	175%
50	34,125	6,000	\$ 102,930	\$ 96,930	5	284%
100	41,125	7,200	\$ 205,860	\$ 198,660	3	483%
200	55,125	8,400	\$ 411,720	\$ 403,320	2	732%
500	77,000	12,000	\$ 1,029,300	\$ 1,017,300	1	1321%

1 Unit Cost plus estimated installation at 75% of unit cost
 2 \$11.28 x 1/2 capacity x 365, Assumed price includes Btu enriched gas (1.289 MMBtu/Mcf)



Industry Experience

Top five United States companies for emissions reductions using VRUs in 2004

Company	2004 Annual Reductions (Mcf)
Company 1	1,273,059
Company 2	614,977
Company 3	468,354
Company 4	412,049
Company 5	403,454



Industry Experience: Chevron

- 🔥 Chevron installed eight VRUs at crude oil stock tanks in 1996

Project Economics – Chevron				
Methane Loss Reduction (Mcf/unit/year)	Approximate Savings per Unit¹	Total Savings	Total Capital and Installation Costs	Payback
21,900	\$153,300	\$1,226,400	\$240,000	3 months

¹Assumes a \$7 per Mcf gas price; excludes value of recovered natural gas liquids. Refer to the Gas STAR *Lessons Learned* for more information.



Industry Experience: Devon Energy

- 🔥 For 5 years, Devon employed the Vapor Jet system and recovered more than 55 MMcf of gas from crude oil stock tanks
- 🔥 Prior to installing the system, tank vapor emissions were about 20 Mcf per day
- 🔥 Installed a system with maximum capacity of 77 Mcf per day, anticipating production increases
- 🔥 Revenue was about \$91,000 with capital cost of \$25,000 and operating expenses less than \$0.40 per Mcf of gas recovered
 - 🔥 At today's gas prices, payback is less than 5 months

MMcf = million standard cubic feet



Industry Experience: EVRU™

Facility Information

- 🔥 Oil production: 5,000 Barrels/day, 30° API
- 🔥 Gas production: 5,000 Mcf/day, 1060 Btu/cf
- 🔥 Separator: 50 psig, 100°F
- 🔥 Storage tanks: Four 1500 barrel tanks
@1.5 ounces relief
- 🔥 Measured tank vent: 300 Mcf/day @ 1,850 Btu/cf

EVURU™ Installation Information

- 🔥 Motive gas required: 900 Mcf/day
- 🔥 Gas sales: 5,638 MMBtu/day
- 🔥 Reported gas value: \$28,190/day @ \$5/MMBtu
- 🔥 Income increase: \$2,545/day = \$76,350/month
- 🔥 Reported EVRU™ cost: \$75,000
- 🔥 Payout: <1 month

Lessons Learned

- 🔥 Vapor recovery can yield generous returns when there are market outlets for recovered gas
 - 🔥 Recovered high heat content gas has extra value
 - 🔥 Vapor recovery technology can be highly cost-effective in most general applications
 - 🔥 Venturi jet models work well in certain niche applications, with reduced operating and maintenance costs
- 🔥 Potential for reduced compliance costs can be considered when evaluating economics of VRU, EVRU™, or Vapor Jet

Lessons Learned (cont'd)

- 🔥 VRU should be sized for maximum volume expected from storage tanks (rule-of-thumb is to double daily average volume)
- 🔥 Rotary vane or screw type compressors recommended for VRUs where Venturi ejector jet designs are not applicable
- 🔥 EVRU™ recommended where there is a high pressure gas compressor with excess capacity
- 🔥 Vapor Jet recommended where less than 75 Mcf per day and discharge pressures below 40 psig

Discussion Questions

- 🔥 To what extent are you implementing this technology?
- 🔥 How can this technology be improved upon or altered for use in your operation(s)?
- 🔥 What is stopping you from implementing this technology (technological, economic, lack of information, manpower, etc.)?