

Statement of Basis

Permittee **Wesco Operating, Inc., Oil and Gas Operations**

Facility: **Lander Field NW Discharge**
SIC: 1311, Petroleum Production - Crude

Permit Number: WY-0000221

Responsible Official: Robert Kirkwood, Engineer
Wesco Operating Inc.

Facility Contacts: Robert Kirkwood, Engineer
Tom Kirkwood, Engineer
PO Box 1706
Casper, WY 82602

307.265.5178
307.265.1791 fax
tkirkwood@tribcsp.com

Permit Type: Minor, Industrial, non-discharge to surface water,
Indian country, Permit renewal

Facility Location: HWY 789
Lander, WY 82520
Fremont County
42.865833 N, 108.693611 W

Discharge Point (if necessary) 001, South of Lander Field Site into Popo Agie River

Section 1.0 – Background Information

1.1 – Permit history

This Permit renewal is for the management of produced oil, water, and gas from the Wesco Operating Inc. – Lander Field NW Discharge oil production facility. The Lander Field oil production facility is located within the exterior boundaries of the Wind River Indian Reservation at NW ¼ NW ¼ Section 30, Township 2 South, Range 2 East in Fremont County (42.865833 N, 108.693611 W).

This Permit is a renewal of NPDES Permit Number WY-0000221, a no-discharge Permit, which expired on December 31, 2015 and was administratively extended. The permitted facility is an oil and gas separation facility that is owned by Wesco Operating Inc., and is

designed, built and operated so that there is no discharge of produced water. This Permit does not authorize a discharge from the facility, but establishes monitoring and reporting provisions should an unauthorized release of produced water occur from the oil production site.

Section 2.0 – Produced Oil and Gas Separation and Wastewater Management (see Figures 1 and 2)

The Lander Field NW facility provides separation treatment for the produced oil and gas generated from approximately 60 oil wells. Pumped liquids are transported to the header building, then to the three horizontal Free Water Knockout (FWKO) tanks where initial oil/water separation takes place. Oil from the FWKO tanks is transported to the three heater treaters and water is transferred to two water skim tanks (1,000 barrels capacity each).

The heat treater tanks are vertical and allow phase separation of the gas, oil and water. A burner tube, operating above 100° F, runs through the middle of vertical tank. The separated water from the heat treater tanks is transferred to the wooden pit (4,229 barrels capacity). The separated oil and gas produced from the heat treater tanks are collected and sent off-site via truck.

Separated water from the skim tanks is transferred to either 1) water flooding/injection (7,000 barrels/day) 2) a concrete pit (749 barrels capacity) or 3) the wooden pit (4,229 barrels capacity). Water from the concrete pit is sent to the wooden pit and water from the wooden pit can be recycled back to the skim tank if additional skimming is needed.

There is a T-siphon in the wooden pit that leads to a large earthen safety pit 1 (21,360 barrels capacity). However, the Permittee has noted that under normal conditions there should be no water transferred to the earthen safety pit. This safety pit has a high water level/overflow pipe that would discharge via outfall 001. If a significant upset occurs at the facility's treatment plant that releases enough wastewater volume to fill all pits, then a discharge to the receiving stream will likely occur. Any discharge from earthen safety pit would discharge to the Popo Agie River via outfall 001, however, the earthen pit has a high water level float valve that is connected to a callout system for notification should a high water level mark occur. The high water notification level is approximately three feet before a discharge would occur through the outfall pipe. There has been no discharge for at least the last five-year Permit cycle.

The Permittee is required to maintain no discharge from the oil and gas production facility except in accordance with the bypass provisions of the Permit. A discharge would occur from the site only after the three pits (concrete, wooden and earthen) are filled to capacity. Discharges from this system would enter the Popo Agie River. However, the Permit does not authorize a discharge to Popo Agie River.

Figure 1 – Wesco Operating, Inc. - Lander Field – Process Flow Schematic

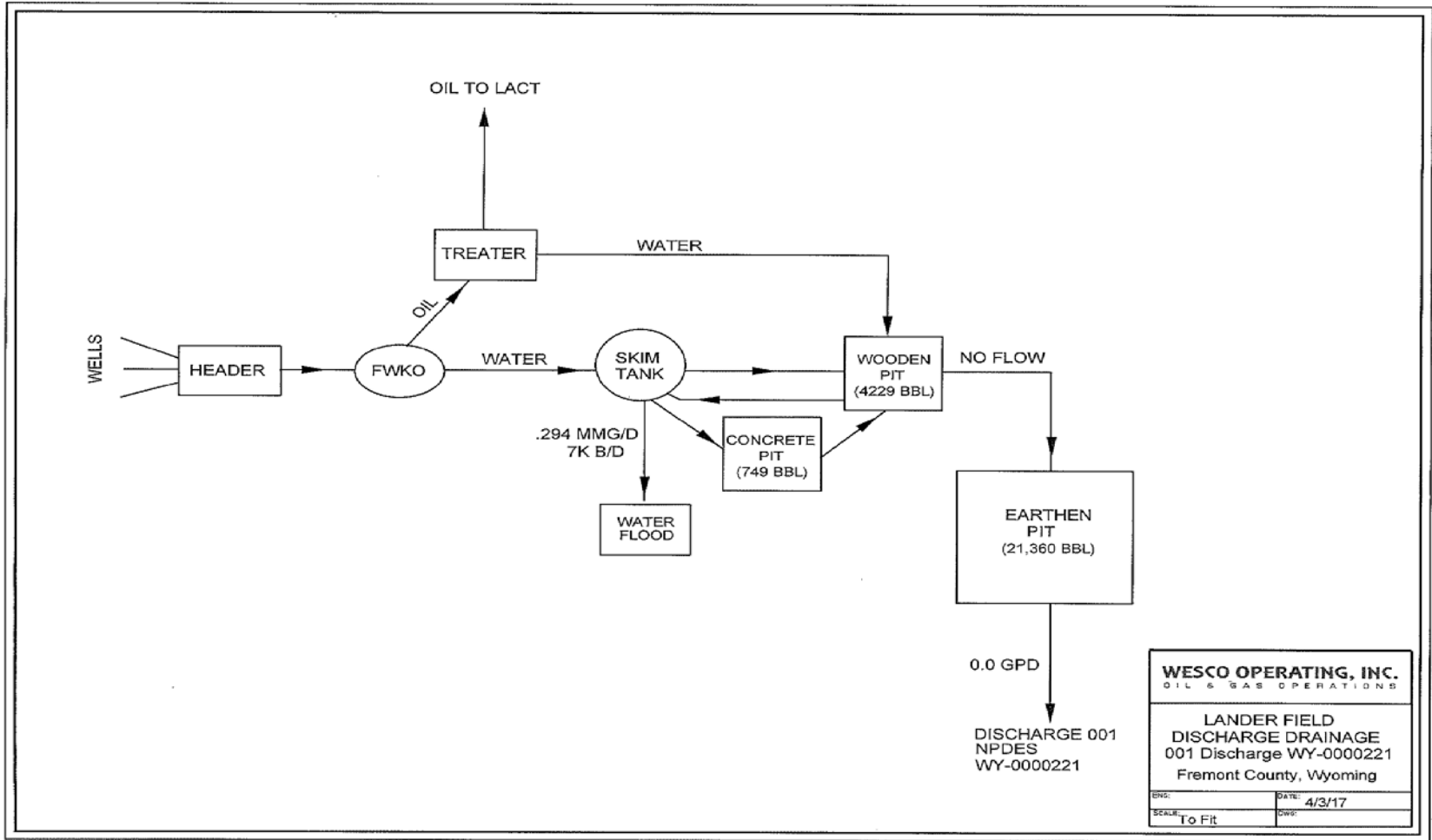
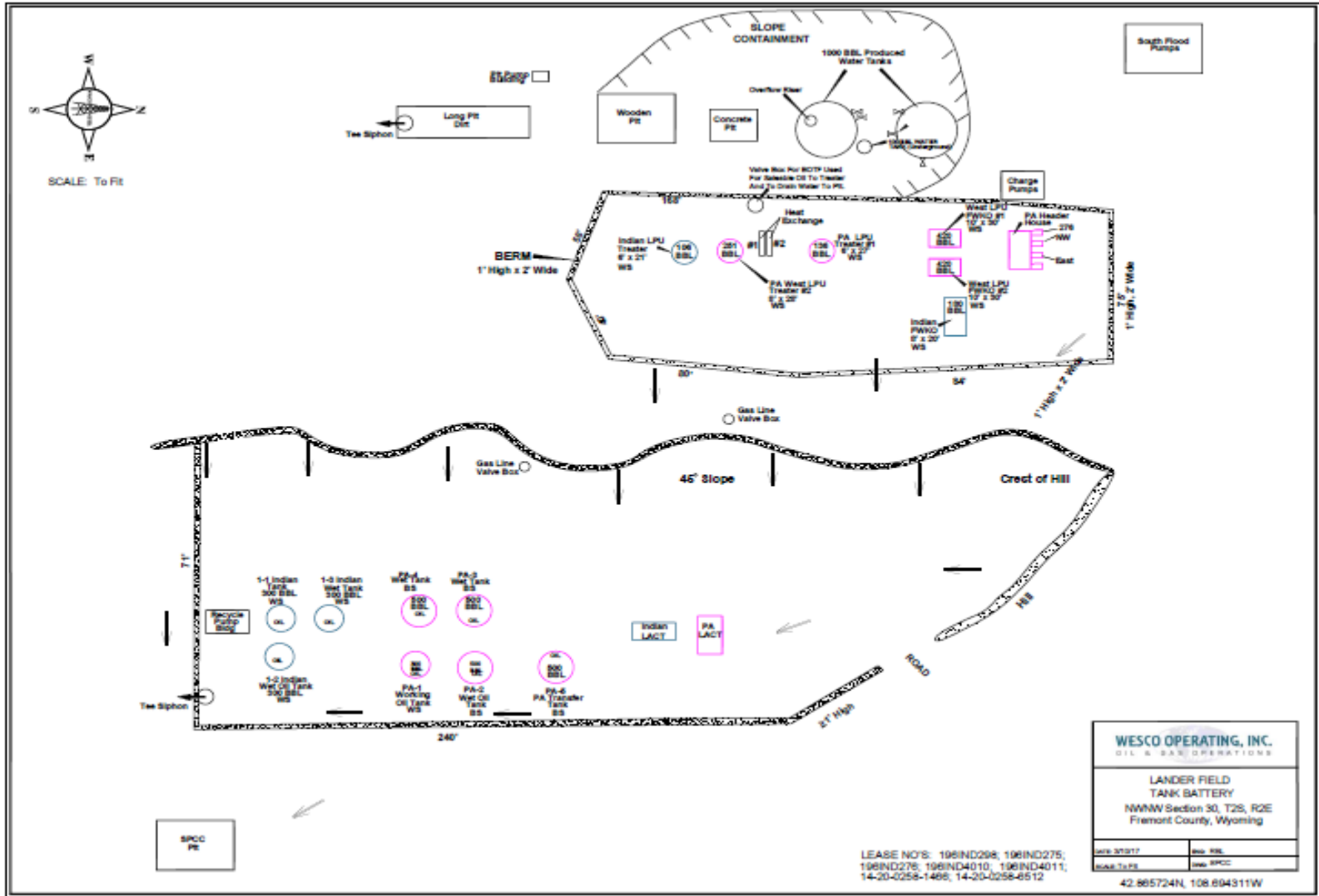

Figure 2 - Wesco Operating, Inc. - Lander Field - Site



Section 3.0 –Effluent Limitations

As in the previous Permit, there shall be no discharge except in accordance with the bypass provisions of the Permit; therefore no effluent limitations are included in this Permit. The Permittee has maintained no discharge of produced water in previous Permits and does not anticipate any discharges in the future. If the Permittee begins to produce a significant volume of produced water and anticipates a need to discharge, then the Permittee is required to obtain a Permit modification.

Section 4.0 – Self-Monitoring and Reporting Requirements

The following self-monitoring and reporting requirements are included in this Permit in the event of an unauthorized release of produced water from the oil production site.

4.1 – Monitoring Requirements

Sampling and test procedures for pollutants listed in this part shall be in accordance with guidelines promulgated in 40 CFR Part 136. The self-monitoring requirements are shown in Table 1.

Table 1– Monitoring Requirements		
Parameter	Frequency	Sample Type <u>a/</u>
Total Flow, gallons <u>b/</u>	<u>c/</u>	Instantaneous
Specific Conductance, umhos/cm	<u>c/</u>	Grab
Total Dissolved Solids, mg/L	<u>c/</u>	Grab
Sulfide (as H ₂ S), mg/L	<u>c/</u>	Grab
Chlorides, mg/L	<u>c/</u>	Grab
pH, std units	<u>c/</u>	Grab
Sulfates, mg/L	<u>c/</u>	Grab
Total Radium 226, pCi/l	<u>c/</u>	Grab
Oil and grease, mg/L	<u>c/</u>	Grab

a/ see definitions, Permit, Section 1.1

b/ The Permittee may estimate the rate of discharge if it is not possible to measure. The Permittee shall monitor the duration of discharge and estimate total volume of discharge.

c/ The discharge shall be monitored daily as soon as practical after the unauthorized release is discovered. The discharge shall be monitored at a daily frequency until the unauthorized release is terminated.

4.2 – Reporting Requirements

If there have been no unauthorized releases during the calendar year, the Permittee must submit “No Discharge During Calendar Year XXXX” Certification (see page 15 of the Permit) postmarked no later than January 28. The XXXX is the calendar year for which no discharge is being reported. The Permittee must sign and certify all submissions in accordance with the requirements of Part 4.7 of this Permit (“Signatory Requirements”).

Section 5.0 – Miscellaneous

5.1 –Impacts to the Endangered Species Act

Section 7(a) of the Endangered Species Act requires federal agencies to ensure that any actions authorized, funded, or carried out by an Agency are not likely to jeopardize the continued existence of any federally-listed endangered or threatened species or adversely modify or destroy critical habitat of such species.

Per the U. S. Fish and Wildlife Service Information for Planning and Consultation website (IPaC), the federally listed threatened, endangered and candidate species found in Fremont County, Wyoming include:

<u>Species</u>	<u>Status</u>
Least Tern (<i>Sterna antillarum</i>)	E
Piping Plover (<i>Charadrius melodus</i>)	T
Whooping Crane (<i>Grus americana</i>)	E
Yellow-billed Cuckoo (<i>Coccyzus americanus</i>)	T
Whitebark Pine (<i>Pinus albicaulis</i>)	C
Bonytail Chub (<i>Gila elegans</i>)	E
Colorado Pikeminnow (=squawfish) (<i>Ptychocheilus lucius</i>)	E
Humpback Chub (<i>Gila cypha</i>)	E
Pallid Sturgeon (<i>Scaphirhynchus albus</i>)	E
Razorback Sucker (<i>Xyrauchen texanus</i>)	E
Desert Yellowhead (<i>Yermo xanthocephalus</i>)	T
Fremont County Rockcress (<i>Boechera pusilla</i>)	C
Ute Ladies Tresses (<i>Spiranthes diluvialis</i>)	T
Western Prairie Fringed Orchid (<i>Platanthera praeclara</i>)	T
Grizzly Bear (<i>Ursus arctos horribillis</i>)	T
Canada Lynx (<i>Lynx canadensis</i>)	T
North American Wolverine (<i>Gulo gulo luscus</i>)	PT

T Threatened PT Proposed Threatened
 E Endangered C Candidate

Potential effects to critical habitats must be analyzed along with the endangered species themselves. Per IPac, Fremont County also overlaps the critical habitats for the following species:

Canada Lynx (<i>Lynx canadensis</i>)	F
Desert Yellowhead (<i>Yermo xanthocephalus</i>)	F

F Final Designated

It does not appear likely, based on recent plant performance, that a treatment plant upset will occur resulting in a discharge to the Popo Agie River. Therefore, this Permit renewal is not likely to adversely affect the endangered species or critical habitats of the Popo Agie River. The U.S. FWS has the federal responsibility to oversee the Wesco Operating, Inc. Lander Field and to meet regulations pertaining to U.S. FWS threatened and endangered species. The U.S. FWS concurred with the EPA’s determination that this Permit is “may affect, not likely to adversely affect” on June 30, 2017.

5.2 –Impacts to the Historic Preservation Act

Section 106 of the National Historic Preservation Act (NHPA), 16 U.S.C. § 470(f) requires that federal agencies consider the effects of federal undertakings on historic properties. EPA has evaluated its planned reissuance of the NPDES Permit for Wesco Operating, Inc. – Lander Field to assess this action’s potential effects on any listed or eligible historic properties or cultural resources. This correspondence is typically conducted with the Tribal Historic Preservation Office (THPO).

EPA does not anticipate any impacts on listed/eligible historic or cultural properties because this Permit is a renewal and will not be associated with any new ground disturbance or changes to the volume or point of discharge. During the public comment period, EPA notified the THPOs of the Northern Arapaho and Eastern Shoshone Tribes of the planned issuance of this NPDES Permit and requested their input on potential effects on historic properties and EPA’s preliminary determination in this regard. EPA did not receive any information from the THPOs of the Northern Arapaho and Eastern Shoshone Tribes during the public comment period.

5.3 – Public Notice

The Permit including the Statement of Basis was public noticed for thirty days in the The Ranger newspaper on August 11, 2017. EPA did not receive any comments during the public notice period.