

**FEDERAL SYNTHETIC MINOR NEW SOURCE REVIEW PERMIT  
ISSUED PURSUANT TO THE REQUIREMENTS OF 40 CFR § 49.158**

PERMITTING AUTHORITY: United States Environmental Protection Agency, Region 6

PERMITEE: Enterprise Field Services LLC  
1100 Louisiana Street  
Houston, Texas 77002

PERMIT NUMBER: R6NSR-NM-005

FACILITY: Lindrith Compressor Station  
SIC 4922, NACIS 486210

FACILITY LOCATION: 20 miles west of Lindrith  
1.5 miles east of State Highway 403  
Jicarilla Apache Reservation,  
Rio Arriba County, New Mexico  
Latitude 36.3105 N and Longitude 107.39639 W

Pursuant to Section 110(a)(2)(c) of the Clean Air Act (CAA), 42 U.S.C. § 7410(a)(2)(C), and 40 CFR §§ 49.151- 49.161, the U.S. Environmental Protection Agency, Region 6 is issuing a *Synthetic Minor New Source Review Permit* for an existing, operating source to Enterprise Field Services LLC, Lindrith Compressor Station (Lindrith). This permit places practical enforceable restrictions on the potential to emit of an existing source so that the provisions and requirements for major sources at 40 CFR § 52.21 will not apply to the source.

This authorization relates to an existing source consisting of three natural gas-fired reciprocal internal combustion engines, one emergency diesel-fired engine, eight storage tanks and a loading station. Enterprise is authorized to operate Lindrith as a synthetic minor source in accordance with the terms and conditions set forth in this permit. Failure to comply with any term or condition set forth in this permit may result in enforcement action pursuant to Section 113 of the CAA. The permit does not relieve Enterprise Field Services LLC (Enterprise) of the responsibility to comply with any other applicable provision of the CAA or other federal and tribal requirements.

In accordance with 40 CFR § 49.159(a)(3), this synthetic minor new source review permit becomes effective immediately.

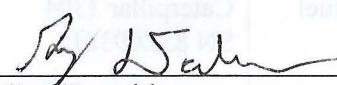
  
\_\_\_\_\_  
Guy Donaldson  
Associate Director for Air  
Multimedia Division

MAR 07 2018  
\_\_\_\_\_  
Date

## Federal Synthetic Minor New Source Review Permit

R6NSR-NM-005

### I. PROJECT DESCRIPTION

The existing Lindrith Compressor Station (Lindrith) is located on Jicarilla Apache land in New Mexico. Enterprise Field Services LLC (Enterprise or Permittee) has requested that EPA rescind their current 1997 PSD permit and convert it to a synthetic minor new source review (NSR) permit. Enterprise has also has requested an amendment to the VOC emission limits to accommodate additional condensate product generated from the compressor station. The permit will not authorize any construction or physical modification to the current facility. The gathering system/pipeline from well production sites feeds Lindrith, where the gas is compressed from 60 psig to 220 psig and finally discharged to the transmission pipeline. The condensate generated at Lindrith is collected in eight storage tanks and loaded on to trucks which are taken offsite.

This synthetic minor NSR permit will limit the source's potential to emit (PTE) of each regulated air pollutant below the major source permitting threshold of 250 tpy for this source category [40 CFR 52.21]. As provided by 40 CFR § 49.151(c)(ii), this permit will include operational throughput limitations and the use of control devices on two reciprocal internal combustion engines (RICE).

### II. EQUIPMENT LIST

Table 1 and the process diagram indicates the equipment subject to 40 CFR § 49.158.

Table 1

|  | EPN         | Construction date | Capacity                      | Content/Fuel                         | Serial No. or Manufacturer         |
|--|-------------|-------------------|-------------------------------|--------------------------------------|------------------------------------|
| 4SLB RICE, with catalytic oxidation control  | A-01        | 4-17-95           | 3267 HP<br>22.09MMBtu<br>u/hr | Natural gas                          | Caterpillar 3612 LE<br>SN 1YG00055 |
| 4SLB RICE, with catalytic oxidation control  | A-02        | 5-1-95            | 3267 HP<br>22.09<br>MMbtu/hr  | Natural Gas                          | Caterpillar 3612 LE<br>SN 1YG00050 |
| 4SLB RICE- No controls                       | A-03        | 5-15-95           | 3267 HP<br>22.09<br>MMBtu/hr  | Natural gas                          | Caterpillar 3612 LE<br>SN 1YG00064 |
| Inlet Separator<br>Pressurized- no emissions |             |                   |                               | Gathering<br>line gas/<br>condensate |                                    |
| Emergency Generator<br>engine                | EMERGEN     | 5-1-95            | 192 HP<br>1.30<br>MMBtu/hr    | Diesel fuel                          | Caterpillar 3304<br>SN 83Z09381    |
| Condensate tanks                             | T1 to<br>T8 | circa 1995        | 454 bbl each                  | Condensate                           | Fixed Roof                         |
| Loading System                               | L-load      | 1995              | 60,000<br>bbls/yr             | Condensate                           | No controls                        |

## Lindrith Compressor Station Process Flow Diagram

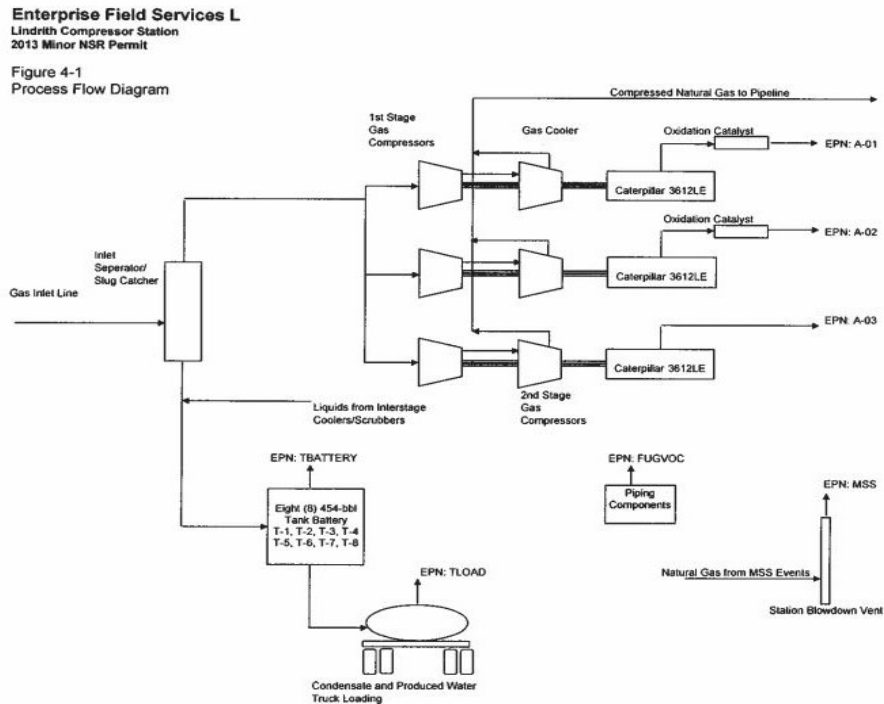

### III. REGULATORY APPLICABILITY

1. The compressor engines, EPN A-01 and A-02 will operate at all times with the catalytic oxidation control device. The three compressor engines are subject to 40 CFR § 63.6590(b)(3)(ii), and will meet all the Special Conditions of the permit in Section V.
2. The emergency generator EPN EMERGEN is subject to the 40 CFR Part 63, Subpart ZZZZ requirements for emergency generators - 40 CFR § 63.6002, Table 2c.
3. 40 CFR § 60.110(b)(d)(4) exempts vessels up to 10,000 bbl volume that are used for condensate storage prior to custody transfer.
4. Existing emission sources, not specifically identified within this permit, are authorized to continue to operate as demonstrated in the permit application. These emission sources are subject to applicable federal standards and are considered insignificant emission units for purposes of this permit. The volume of the tanks, VOC content of the product in the tanks and flow rates are below the thresholds of any applicable tank regulations, and are considered insignificant emission units. These tanks/units are listed in Appendix A.

## Federal Synthetic Minor New Source Review Permit

R6NSR-NM-005

### IV. GENERAL CONDITIONS

1. This permit and any required attachments shall be retained and made available for inspection upon request at the site.
2. All representations, statements of intent, and agreements contained in the application and other materials submitted by the Permittee shall be enforceable. The EPA shall be notified ten (10) days in advance of any significant deviation from the permit application as well as any plans, specifications or supporting data furnished.
3. The Permittee shall comply with all conditions of this permit, including emission limitations that apply to the affected emissions units at the permitted source. Noncompliance with any permit term or condition is a violation of the permit and may constitute a violation of the CAA and is grounds for an enforcement action and for a permit termination or revocation [40 CFR § 49.157(a)(7)(i)].
4. Emissions from the permitted source shall not cause or contribute to a National Ambient Air Quality Standard (NAAQS) violation or cause or contribute to a Prevention of Significant Deterioration (PSD) increment violation [40 CFR § 49.155(a)(7)(ii)].
5. Issuance of this permit does not relieve the Permittee, the owner, and/or the operator of the responsibility to comply fully with all other applicable Federal and Tribal rules, regulations, and orders now or hereafter in effect.
6. The issuance of this permit does not provide relief for any federal applicable regulations that the facility may have been subject to including 40 CFR Part 49, 40 CFR Part 52, 40 CFR Part 60, 40 CFR Part 63, or 40 CFR Part 71, prior to issuance of this permit
7. It is not a defense for the Permittee, in an enforcement action, to claim that it would have been necessary to halt or reduce the permitted activity in order to maintain compliance with the conditions of this permit.
8. For proposed modifications, as defined at 40 CFR § 49.152(d), that would increase an emissions unit's allowable emissions of a regulated NSR pollutant above its existing permitted annual allowable emissions limit, the Permittee shall first obtain a permit modification pursuant to 40 CFR §§ 49.154 and 49.155 approving the emission increase. For a proposed modification that is not otherwise subject to review under major NSR or minor NSR, such proposed increase in the annual allowable emissions limit shall be approved through an administrative permit revision as provided at 40 CFR § 49.159(f)(1)(v).
9. At such time that a new or modified source at the permitted facility or modification of the permitted facility becomes a major stationary source or major modification solely by virtue of a relaxation in any legally and practically enforceable limitation which was established after August 7, 1980, on the capacity of the permitted facility otherwise to emit a pollutant, such as a restriction on hours of operation, then the requirements of 40 CFR § 52.21 shall apply to the

Federal Synthetic Minor New Source Review Permit

R6NSR-NM-005

source or modification as though construction had not yet commenced on the source or modification.

10. *Revise, Reopen, Revoke and Reissue, or Terminate for Cause:* The permit may be revised, reopened, revoked and reissued or terminated for cause. The filing of a request by the Permittee for a permit revision, revocation and re-issuance or termination, or of a notification of planned changes or anticipated noncompliance does not stay any permit condition [40 CFR § 49.155(a)(7)(iv)]. The EPA may reopen a permit for a cause on its own initiative, e.g., if the permit contains a material mistake or the facility fails to assure compliance with the applicable requirements.
11. *Severability Clause:* The provisions of this permit are severable, and in the event of any challenge to any portion of this permit, or if any portion is held invalid, the remaining permit conditions shall remain valid and in force.
12. *Property Rights:* The permit does not convey any property rights of any sort or any exclusive privilege.
13. *Information Requests:* The Permittee shall furnish to the EPA, within a reasonable time, any information that the EPA may request in writing to determine whether cause exists for revising, revoking and reissuing, or terminating the permit or to determine compliance with the permit. For any such information claimed to be confidential, the Permittee shall also submit a claim of confidentiality in accordance with 40 CFR Part 2, Subpart B.
14. *Inspection and Entry:* The EPA or its authorized representatives may inspect the permitted facility during normal business hours for the purpose of ascertaining compliance with all conditions of this permit. Upon presentation of proper credentials, the Permittee shall allow the EPA or its authorized representative to:
  - a. Enter upon the premises where a source is located or emissions-related activity is conducted, or where records are required to be kept under the conditions of the permit;
  - b. Have access to and copy, at reasonable times, any records that are required to be kept under the conditions of the permit;
  - c. Inspect, during normal business hours or while the source is in operation, any facilities, equipment (including monitoring and air pollution control equipment), practices or operations regulated or required under the permit;
  - d. Sample or monitor, at reasonable times, substances or parameters for the purpose of assuring compliance with this permit or other applicable requirements; and
  - e. Record any inspection by use of written, electronic, magnetic and photographic media.
15. *Effective Date:* This permit is effective immediately upon issuance unless comments resulted in a change in the draft permit, in which case the permit is effective 30 days after issuance. The Permittee may notify the EPA, in writing, that this permit or a term or condition of it is rejected. Such notice should be made within thirty days of receipt of the permit and should include the reason or reasons for rejection.

Federal Synthetic Minor New Source Review Permit

R6NSR-NM-005

16. *Permit Transfers*: Permit transfers shall be made in accordance with 40 CFR § 49.159(f). The Air Program Associate Director shall be notified in writing/electronically at the address shown below if the company is sold or changes its name.

U.S. Environmental Protection Agency  
 Region 6 Air Permitting, Multimedia Division  
 Tribal Air Permitting, 6MM-AP  
 1445 Ross Ave, Dallas TX 75202  
[R6AirPermits@epa.gov](mailto:R6AirPermits@epa.gov)

**V. SPECIAL CONDITIONS**

1. The permittee shall comply with the emission limitations (in tons per year) identified in Table 2.

**Table 2**

| Emission Unit Description   | EPN <sup>1</sup> | NO <sub>x</sub> | VOC    | SO <sub>2</sub> | PM <sub>10</sub> | PM <sub>2.5</sub> | CO     | HAP <sup>2</sup> |
|---|------------------|-----------------|--------|-----------------|------------------|-------------------|--------|------------------|
| Caterpillar 3612LE (NG-fired Engine) with catalytic control.            | A-01             | 22.09           | 20.54  | 1.42            | 0.97             | 0.97              | 11.83  | 10.28            |
| Caterpillar 3612LE (NG-fired Engine) with catalytic control             | A-02             | 22.09           | 20.54  | 1.42            | 0.97             | 0.97              | 11.83  | 10.28            |
| Caterpillar 3612LE (NG-fired Engine)                                    | A-03             | 22.09           | 29.34  | 1.42            | 0.97             | 0.97              | 78.88  | 14.69            |
| Emergency Generator Caterpillar 3304 (Diesel-fired engine) <sup>3</sup> | EMERGEN          | 0.02            | 0.01   | <.001           | 0.002            | 0.002             | 0.03   |                  |
| Maintenance, startup and shutdown for the facility <sup>5</sup>         | MSS              |                 | 30.00  |                 |                  |                   |        | 0.64             |
| Fugitives for facility <sup>4</sup>                                     | FUGVOC           |                 | 3.31   |                 |                  |                   |        | 0.03             |
| Condensate Tanks T1-T8  | TBATTERY         |                 | 102.63 |                 |                  |                   |        | 1.32             |
| Loading System at 60,000 bbls/yr  | TLOAD            |                 | 4.98   |                 |                  |                   |        | 0.07             |
| <b>TOTALS in tpy</b>  |                  | 66.29           | 211.34 | 4.26            | 2.91             | 2.91              | 102.57 | 37.31            |

Notes for table 2.

1. Emission Point Number
2. HAP emissions are primarily formaldehyde emissions
3. The emission calculations are based on 50 hrs/yr for maintenance and testing purposes only.
4. Fugitive emissions are estimated and not required to be monitored and are not enforceable.
5. MSS emissions include, but are not limited to compressor shutdowns, vessel and piping blowdowns, pigging activities.

Federal Synthetic Minor New Source Review Permit

R6NSR-NM-005

2. The fuel for the compressor engines (EPNs A-01, A-02, and A-03) shall be field natural (field) gas. The quantity of field gas to *each* compressor engine (A-01, A-02, and A-03) shall be calculated using the run time meters for each compressor and the total field gas flow meter to the compressors. The flow shall not exceed 213.83 MMSCF/yr, for each engine based on a 12-month rolling average.
3. Field gas is limited to  $\leq 0.25$  grains of hydrogen sulfide per 100 dry standard cubic feet and is required to be analyzed every 12 months to determine Btu content.
4. All meters used to provide data to determine compliance with the permit limits shall be calibrated annually and may use the procedures specified by the instrument meter manufacturer, or a method published by a consensus-based standards organization such as ASTM or API, or AGA.
5. Samples of the condensate to TBATTERY should be analyzed on an annual basis to determine the molecular weight, vapor pressure and temperature, using standard industrial methods. The analyses should not be performed more than 365 days apart.
6. For each engine and its respective catalytic control system, the Permittee shall follow the manufacturer recommended maintenance schedule and procedures or equivalent maintenance schedule and procedures developed by the Permittee or vendor to ensure optimum performance of each engine and its respective catalytic control system. See Appendix B.
7. The engine exhaust temperature for the two compressor engines [EPN A-01 and EPNA-02] shall be monitored at the inlet of the oxidation catalyst system and be always maintained between the minimum and maximum parameters as in the warranty representation of the catalyst manufacturer. If the engines operate outside the parameters corrective action as stated in Special Condition V.9 should be taken.
8. Continuous catalyst performance shall also be demonstrated by the pressure drop and temperature differential across the catalyst and shall not exceed the recommendation from the catalyst manufacturer or plus 10% from the baseline pressure drop across the catalyst measured during the initial performance test. If the pressure drop exceeds the limits stated above, corrective action (Special Condition V.9) should be taken immediately. See Appendix B for representative catalyst monitoring.
9. Upon determining a deviation from the monitoring as stated above in Special Conditions 6,7, and 8, corrective action shall be taken to assess the performance problems of the oxidation catalyst. If immediate remedy is not possible, then the affected engine shall cease operating within 24 hours and shall not be returned to routine service until the deviation is resolved. EPA will be notified of the problem as noted in Section VIII.
10. The short term limit for these engines are in the Table 3 below and are verified using the CO analyzer as required in Special Condition V.11.

Federal Synthetic Minor New Source Review Permit

R6NSR-NM-005

Table 3

| Unit ID | Load | NOx     | NOx    | CO      | CO     | VOC     | VOC    |
|---------|------|---------|--------|---------|--------|---------|--------|
|         | %    | g/hp-hr | lbs/hr | g/hp-hr | lbs/hr | g/hp-hr | lbs/hr |
| A-01    | 100  | 0.70    | 5.04   | 0.38    | 2.70   | 0.65    | 4.69   |
| A-02    | 100  | 0.70    | 5.04   | 0.38    | 2.70   | 0.65    | 4.69   |
| A-03    | 100  | 0.70    | 5.04   | 2.50    | 18.01  | 0.93    | 6.70   |

11. The CO emission limits in Table 3 shall be monitored by a calibrated portable CO emission analyzer on a quarterly basis. The portable analyzer and monitoring shall be conducted in accordance with the requirements of the current version of ASTM D 6522. If the CO emissions exceed the limit in Table 3, corrective action noted in Special Condition V.9 shall be taken.
12. Diesel fuel in the emergency generator is limited to 15 ppm, sulfur content. Operations of the generator when tested or used should be recorded and monitored using the non-resettable meter.
13. There shall be no visible emissions during the startup and testing of the emergency generator engine, except for an initial two-minute interval.
14. There is no time limit on the use of emergency stationary RICE in emergency situations.
15. EMERGEN may be operated for periods where there is a deviation of voltage or frequency of 5% or greater below standard voltage or frequency.
16. For testing and readiness purposes, EMERGEN shall not be operated more than 50 hours per calendar year [40 CFR § 63.6640(f)].
17. EMERGEN shall not be used for peak shaving or non-emergency demand response, or to generate income from supplying power to an electric grid or otherwise supply power as part of a financial arrangement with another entity.
18. For EMERGEN the maintenance shall be performed in accordance with 40 CFR § 63.6002, Table 2c.
19. Condensate flow to inlet shall be determined by the truck loading tickets and shall not exceed 60,000 bbls/yr based on a 12 -month rolling average. This flow shall be used to calculate the emissions from TBATTERY tanks.
20. Loading emissions shall be calculated on a 12-month rolling basis using truck loading tickets and not exceed 60,000 bbls/yr.



Federal Synthetic Minor New Source Review Permit

R6NSR-NM-005

21. The tanks shall be maintained for integrity and the tank and loading operations shall be conducted without any spills or visible emissions.

**VI. COMPLIANCE TESTS:**

1. An initial test to determine the emissions from the compressor engines, the efficiency of the oxidation catalyst system shall be conducted within 180 days of the issuance of this permit. Thirty (30) days prior to the emission tests, a test plan shall be sent to EPA Region 6 Compliance Assurance and Enforcement Division for review at: [R6TribalNSRCompliance@epa.gov](mailto:R6TribalNSRCompliance@epa.gov)
2. At a minimum, the test plan should provide the following details:
  - a. Purpose of the test (initial, periodic, catalyst replacement etc.);
  - b. The proposed date, time and name of person that will be performing the test;
  - c. Engines and catalytic control systems to be tested;
  - d. Tests to be conducted at maximum capacity, 75% and 50% capacity of each engine, to confirm the emission factors for the pollutants. If the maximum capacity cannot be achieved, the testing will be conducted at the maximum achievable load under prevailing operating conditions. However, additional testing may be required should the engines operate at higher than + 10% of the maximum tested load;
  - e. Sampling and analysis procedures to include sampling locations, test methods and laboratory identification;
  - f. Quality assurance plan which includes calibration procedures and frequency, sample recovery and field documentation, chain of custody procedures; and
  - g. Data processing and reporting with the description of data handling and quality control procedures in the final report.
3. Each test shall consist of at least three 1-hour or longer valid test runs. Emission results shall be reported as the arithmetic average of all valid test runs and shall be in terms of the emission limits in this permit.
4. The tests shall meet the minimum specification requirements for the catalyst.
5. For the initial test, the condensate shall be sampled and analyzed to determine the vapor pressure in psia, components of the condensate, temperature and molecular weight. This data shall be used in the calculation methodology for the tanks and loading emissions to determine compliance with the emission limits in Table 2.
6. The result of the tests shall be submitted to EPA within sixty (60) days of completion of the tests.
7. Periodic compliance tests may be required upon a request from the EPA.

**VII. RECORDKEEPING AND MONITORING REQUIREMENTS**

1. The permittee shall keep records of all monitoring data, equipment calibration, maintenance, inspections, Data Acquisition and Handling System (DAHS) if used, reports, and other supporting information required by this permit for at least five (5) years from the time the data was gathered or the reports written. Each record shall clearly identify the emissions unit and/or monitoring equipment, and the date the data was gathered.
2. Monitor and maintain records on the duration of the operation of EMERGEN to include readiness tests.
3. Monitor and record the field natural gas flow rate to each compressor engine and keep records of the flow to each unit on a 12-month rolling average.
4. Calculate and record the MMBtu/hr to each engine based on the flow and analyses of the field gas to the units.
5. Record the type of maintenance operations of the compressor engines, catalytic oxidation system, tanks and other pieces of equipment to include the time and date for such an event.
6. Monitor and keep records/logs on the performance of the catalyst oxidation system as in Section V, conditions 7, 8 and 10. The records of the maintenance and operation of the catalyst oxidation system of the catalyst manufacturer should be kept on site and be readily available when requested.
7. Monitor the flow of condensate to the TBATTERY using the truck loading tickets on a monthly basis and record total throughput based on a 12-month rolling basis.
8. Monitor the volume of condensate to TLOAD on a monthly basis using the truck loading tickets, and record totals based on a 12-month rolling basis.
9. Document daily the number of pipeline pigging events to the pipeline pig receiver for MSS emissions and total the daily record for the month. Records shall be kept of the monthly total volume of gas vented during SSM events in MMSCF and of the annual inlet gas analysis specifying the percent VOC. The calculated monthly total shall be used to calculate the monthly rolling 12-month total VOC emissions
10. The permittee shall keep records of the serial numbers for each emission unit listed herein. The emission units and their serial numbers are: A-01 with serial number 1YG00055; A-02 with serial number 1YG00050; A-03 with serial number 1YG00064; and EMERGEN with a serial number 83Z09381. A change in serial number should also be reflected in the report required by Section VIII-2 below.

## VIII. REPORTING REQUIREMENTS

The following reports should be sent electronically to EPA Region 6 Compliance Assurance and Enforcement Division at: [R6TribalNSRCompliance@epa.gov](mailto:R6TribalNSRCompliance@epa.gov), and a copy to [R6AirPermits@epa.gov](mailto:R6AirPermits@epa.gov)

1. The Permittee shall promptly submit to the EPA a written report of any deviations of emission or operational limits and a description of any corrective actions or preventative measures taken. A "prompt" deviation report is one that is emailed to [R6TribalNSRCompliance@epa.gov](mailto:R6TribalNSRCompliance@epa.gov) within the time period below:
  - a. Thirty (30) days from the discovery of a deviation that would cause the Permittee to exceed the facility-wide emission limits if left uncorrected for more than five (5) days after discovering the deviation; and
  - b. Twelve (12) months from the discovery of a deviation of recordkeeping or other permit conditions that do not affect the permittee's ability to meet the facility-wide emission limits.
2. Reports for the replacement and/or repairs of the compressor engines, and use of EMERGEN for emergency purposes.
3. Annual emission reports on the volumes of condensate to the tanks, based on the annual condensate sampling analyses (Section V.5) Emissions shall be calculated using the AP-42 method or any other standard applicable to this facility's operation.
4. An annual report documenting the twelve (12) month annual emissions for each previous calendar year no later than April 1<sup>st</sup> is to be submitted to EPA to the electronic addresses as indicated above. For the first calendar year, the Permittee shall submit the cumulative facility wide limits. The report shall also document that no operational restriction established in the special conditions section of this permit has been exceeded.
5. The Permittee shall submit any record or report required by this permit upon EPA request.

Federal Synthetic Minor New Source Review Permit

R6NSR-NM-005

**Table of Acronyms**

|                 |  |
|-----------------|--|
| AGA             | American Gas Association                                 |
| API             | American Petroleum Institute                             |
| ASTM            | American Society for Testing and Materials               |
| 4SLB            | 4 Stroke Lean Burn                                       |
| CT              | Control Technology                                       |
| bhp /HP         | Brake Horse Power  |
| Btu/hr          | British Thermal Units per Hour                           |
| bbbl            | Barrels  |
| CFR             | Code of Federal Register                                 |
| CH <sub>4</sub> | Methane  |
| CAA             | Clean Air Act  |
| CO              | Carbon Monoxide  |
| dscf            | Dry Standard Cubic Feet                                  |
| FIP             | Federal Implementation Plan                              |
| FR              | Federal Register   |
| HHV             | High Heating Value                                       |
| HAP             | Hazardous Air Pollutants                                 |
| hr              | Hour   |
| kW              | Kilowatt   |
| lb              | Pound(s)   |
| lb/yr           | Pounds per year  |
| MACT            | Maximum Achievable Control Technology                    |
| MMBtu/hr        | Million British Thermal Units per hour                   |
| MMSCF           | Million Standard Cubic Feet                              |
| NESHAP          | National Emission Standards for Hazardous Air Pollutants |
| NSPS            | New Source Performance Standard                          |
| NO <sub>x</sub> | Oxides of Nitrogen                                       |
| NSR             | New Source Review  |
| PTE             | Potential to Emit  |
| RICE            | Reciprocating Internal Combustion Engine                 |
| tpy             | Tons per year  |
| VOC             | Volatile Organic Compounds                               |
| %               | Percent  |

Federal Synthetic Minor New Source Review Permit

R6NSR-NM-005

APPENDIX A

INSIGNIFICANT EMISSION UNITS

Three-300 gallons Lube Oil Tank  
One-500 gallons Lube Oil Tank  
One 120 bbl below ground Waste Oil Tank  
One 250 bbl Methanol Tank  
One 100 bbl Methanol Tank

**Appendix B****Typical Oxidation Catalyst Maintenance****6.0 MAINTENANCE**

DCL's recommended monitoring and maintenance schedule during operation is given below. Due to large variations in operating conditions, the schedule may change depending on the specifics of the application. In addition to this schedule, additional monitoring and reporting may be needed according to the requirements of your environment permit.

It is recommended that a maintenance log be maintained. Measurements and records of temperature difference ( $\Delta T$ ) and pressure difference ( $\Delta P$ ) should always be made under the same operating conditions (e.g. engine load, speed, ignition timing and exhaust oxygen concentration).

**Monitoring and Maintenance Schedule**

| Item No. | Description                             | > 4000 hours operation per year   | 500 – 3999 hours operation per year   | < 500 hours operation per year  | Directions  |
|----------|---|---|---|---|---|
| 1        | Check back-pressure ( $\Delta P$ )      | <ul style="list-style-type: none"> <li>At time of installation</li> <li>Every 3 months</li> </ul> | <ul style="list-style-type: none"> <li>At time of installation</li> <li>Every 6 months</li> </ul> | <ul style="list-style-type: none"> <li>At time of installation</li> <li>Every year</li> </ul> | If the ( $\Delta P$ ) is more than 55 mm H <sub>2</sub> O (2" H <sub>2</sub> O) higher than the initial ( $\Delta P$ ), inspect catalyst for excessive ash build-up. See Section 7 (Troubleshooting).                             |
| 2        | Check temperature change ( $\Delta T$ ) | <ul style="list-style-type: none"> <li>At time of installation</li> <li>Every 3 months</li> </ul> | <ul style="list-style-type: none"> <li>At time of installation</li> <li>Every 6 months</li> </ul> | <ul style="list-style-type: none"> <li>At time of installation</li> <li>Every year</li> </ul> | If the ( $\Delta T$ ) is more than 25 $\Delta F$ (14 $\Delta C$ ) higher than the initial ( $\Delta T$ ), check the engine for misfiring and /or inspect catalyst element for damage or fouling. See Section 7 (Troubleshooting). |
| 3        | Conduct emissions test                  | <ul style="list-style-type: none"> <li>As required by operating permit</li> </ul>                 | <ul style="list-style-type: none"> <li>As required by operating permit</li> </ul>                 | <ul style="list-style-type: none"> <li>As required by operating permit</li> </ul>             | As required by operating permit.  |
| 4        | Visual inspection of catalyst element   | <ul style="list-style-type: none"> <li>Every 2 years</li> </ul>                                   | <ul style="list-style-type: none"> <li>Every 3 years</li> </ul>                                   | <ul style="list-style-type: none"> <li>Every 3 years</li> </ul>                               | See Section 7 (Troubleshooting).  |
| 5        | Chemical cleaning of catalyst element   | <ul style="list-style-type: none"> <li>Every 2 years</li> </ul>                                   | <ul style="list-style-type: none"> <li>Every 3 years</li> </ul>                                   | <ul style="list-style-type: none"> <li>N/A</li> </ul>   | Contact DCL or authorized dealer for assistance.  |

Note: Items 1, 2 and 3 can be conducted by utilizing the ports on the inlet and outlet side of the converter.