

## DEPARTMENT OF ENVIRONMENTAL QUALITY

### AIR QUALITY DIVISION

#### PART 10. INTERMITTENT TESTING AND SAMPLING

##### **R 336.2001 Performance tests by owner.**

Rule 1001. (1) The department may require the owner or operator of any source of air contaminant to conduct acceptable performance tests, at the owner's or operator's expense, in accordance with R 336.2003 under any 1 of the following conditions:

- (a) Prior to issuance of a permit to operate.
- (b) The source is determined to be in violation of R 336.1301 and the potential emissions exceed 100 tons per year.
- (c) The owner or operator of the source has not submitted an acceptable performance test, in accordance with R 336.2003, that demonstrates that the source is in compliance with the department's rules and with the conditions specified in the permit to install.
- (d) The source of air contaminant is located in an area designated as nonattainment for 1 or more air pollutants, and more than 12 months have expired since the date of the last performance test for such designated nonattainment pollutants.
- (e) The source of air contaminant has potential emissions in excess of 100 tons per year, is located in an area designated as attainment for 1 or more air pollutants, and more than 36 months have expired since the date of the last performance test for such designated attainment pollutants.

(f) After completion of a compliance program.

(2) Performance tests required by subrule (1) of this rule shall be conducted within 60 days following receipt of written notification from the department, unless otherwise authorized by the department.

(3) Not less than 7 days before performance tests are conducted, the owner of a source of air contaminant, or his or her authorized agent, shall notify the department, in writing, of the time and place of the performance tests and who shall conduct them. A representative of the department shall have the opportunity to witness these tests.

(4) Results of performance tests shall be submitted to the department in the format prescribed by the applicable reference test method within 60 days after the last date of the test.

History: 1979 ACS 1, Eff. Jan. 19, 1980; 2002 MR 5, Eff. Mar. 19, 2002.

##### **R 336.2002 Performance tests by department.**

Rule 1002. (1) The department may conduct performance tests in accordance with R 336.2003 at any source of air contaminant, on behalf of the state, at a reasonable time and at the state's expense. During the conduct of such tests, the department may obtain samples of any air contaminant and samples of any material entering or exiting the source or air-cleaning device for the purpose of evaluating pollutant emissions with respect to process operating conditions.

(2) The department shall provide written notification to the owner or operator of a source of the department's intent to conduct performance tests pursuant to subrule (1). Within 30 days of receipt of such notification, the owner or operator shall provide, and bear the expense of, performance test facilities as specified by the department, including the following:

- (a) Sampling ports adequate for reference test methods applicable to the source.
- (b) Safe sampling platforms as required.
- (c) Safe access to sampling platforms.

(d) A suitable power source within 50 feet of any sampling location designated by the department. Upon request, additional time for installing the required performance test facilities may be authorized by the department for special situations.

(3) The owner shall not be responsible for providing sampling instruments and sensing devices.

(4) Results of performance tests shall be furnished to the owner or operator, or both, in the format prescribed by the applicable reference test method within 60 days following the last date of the test.

History: 1979 ACS 1, Eff. Jan. 19, 1980; 2002 MR 5, Eff. Mar. 19, 2002.

### **R 336.2003 Performance test criteria.**

Rule 1003. (1) Performance tests shall be conducted and data reduced according to the reference test methods listed in R 336.2004, unless the department does any of the following:

(a) Specifies or approves, in specific cases, the use of a reference test method with minor changes in procedures or equipment.

(b) Approves the use of an equivalent method.

(c) Specifies or approves the use of an alternative method if an applicable reference test method does not exist for a specific air contaminant or source of air contaminant.

(2) A performance test shall consist of a minimum of 3 separate samples of a specific air contaminant conducted within a 36- hour period, unless otherwise authorized by the department. Each of the 3 separate samples shall be obtained while the source is operating at a similar production level. For the purpose of determining compliance with an applicable emission limit, rule, or permit condition, the arithmetic mean of results of the 3 samples shall apply. If a sample is accidentally lost or conditions occur in which 1 of the 3 samples must be discontinued because of forced shutdown, failure of an irreplaceable portion of the sampling train, extreme meteorological conditions, or other circumstances beyond the owner's or operator's control, then compliance may, upon the approval of the department, be determined using the arithmetic mean of the results of 2 samples.

(3) All performance tests shall be conducted while the source of air contaminant is operating at maximum routine operating conditions, or under such other conditions, within the capacity of the equipment, as may be requested by the department. Other conditions may include source operating periods of start-up, shutdown, or such other operations, excluding malfunction, specific to certain sources. Routine operating conditions shall also include those specified within a permit to install or a permit to operate. The owner or operator shall make available to the department such records as may be necessary to determine the conditions of source operation that occurred during the period of time of the performance test.

(4) For any source that is subject to an emission limitation calculated to 50% excess air, the multipoint, integrated sampling procedure of method 3 shall be used for gas analysis. For all other sources that require a determination of the molecular weight of the exhaust, any optional sampling procedure of method 3 may be used. Alternatives or modifications to procedures are subject to the approval of the department.

(5) For reference test methods 5B and 5C, the minimum volume per sample shall be 30 cubic feet of dry gas corrected to standard conditions (70 degrees Fahrenheit, 29.92 in. Hg.). Minimum sample time shall be 60 minutes, which may be continuous or a combination of shorter sampling periods for sources that operate in a cyclic manner. Smaller sampling times or sample volumes, when necessitated by process variables or other factors, may be approved by the department.

History: 1979 ACS 1, Eff. Jan. 19, 1980; 2002 MR 5, Eff. Mar. 19, 2002.

**R 336.2004 Appendix A; reference test methods; adoption of federal reference test methods.**

Rule 1004. (1) The following federal reference test methods, described in the provisions of 40 C.F.R. part 60, appendix A (2005), are the reference test methods for performance tests required pursuant to the provisions of this part:

- (a) Method 1 - Sample and velocity traverse for stationary sources.
- (b) Method 1A - Sample and velocity traverses for stationary sources with small stacks or ducts.
- (c) Method 2 - Determination of stack gas velocity and volumetric flow rate (type-S pitot tube).
- (d) Method 2A - Direct measurement of gas volume through pipes and small ducts.
- (e) Method 2C - Determination of stack gas velocity and volumetric flow rate in small stacks and ducts (standard pitot tube).
- (f) Method 2D - Measurement of gas volumetric flow rates in small pipes and ducts.
- (g) Method 3 - Gas analysis for the determination of dry molecular weight.
- (h) Method 4 - Determination of moisture content in stack gases.
- (i) Method 6 - Determination of sulfur dioxide emissions from stationary sources.
- (j) Method 7 - Determination of nitrogen oxide emissions from stationary sources.
- (k) Method 8 - Determination of sulfuric acid mist and sulfur dioxide emissions from stationary sources.
- (l) Method 9 - Visual determination of the opacity of emissions from stationary sources.
- (m) Method 10 - Determination of carbon monoxide emissions from stationary sources.
- (n) Method 10B - Determination of carbon monoxide emissions from stationary sources.
- (o) Method 18 - Measurement of gaseous organic compound emissions by gas chromatography.
- (p) Method 21 - Determination of volatile organic compound leaks.
- (q) Method 24 - Determination of volatile matter content, water content, density, volume solids and weight solids of surface coatings.
- (r) Method 24A - Determination of volatile matter content and density of printing inks and related coatings.
- (s) Method 25 - Determination of total gaseous nonmethane organic emissions as carbon.
- (t) Method 25A - Determination of total gaseous organic concentration using a flame ionization analyzer.
- (u) Method 27 – Determination of vapor tightness of gasoline delivery tank using pressure-vacuum test.

(2) The reference test methods listed in subrule (1) of this rule are adopted by reference in this rule. Copies of the test methods may be inspected at the Lansing office of the air quality division of the department of environmental quality. A copy of title 40 of the Code of Federal Regulations, part 60, appendix A, may be obtained from the Department of Environmental Quality, Air Quality Division, P.O. Box 30260, Lansing, Michigan 48909-7760; from the Superintendent of Documents, United States Government Printing Office, P.O. Box 371954, Pittsburgh, Pennsylvania 15250-7954, at a cost at the time of adoption of these rules of \$57.00; or on the United States government printing office internet web site at <http://www.access.gpo.gov>.

(3) All alternatives that are subject to the approval of the administrator in the adopted federal reference methods are subject to the approval of the department.

(4) Determinations of compliance with visible emission standards for stationary sources shall be conducted as specified in reference test method 9 or other alternative method approved by the department, with the following exceptions:

- (a) Visible emissions from a scarfing operation at a steel manufacturing facility shall be determined as specified in reference test method 9A, which is described in R 336.2030.
- (b) Visible emissions from a coke oven pushing operation and fugitive coke oven visible emissions shall be determined as specified in reference test method 9B, which is described in R 336.2031.
- (c) Visible emissions, fugitive and nonfugitive, from basic oxygen furnace operations, hot metal

transfer operations, and hot metal desulfurization operations shall be determined as specified in reference method 9C, which is described in R 336.2032.

(5) Determinations of particulate emission rates for stationary sources shall be conducted as specified in 1 or more of the following reference test methods:

(a) Reference test method 5B, which is described in R 336.2011.

(b) Reference test method 5C, which is described in R 336.2012.

(c) Reference test method 5D, which is described in R 336.2013.

(d) Reference test method 5E, which is described in R 336.2014.

(e) "Standard Methods for the Examination of Water and Wastewater," (14th edition), section 208C, as described and modified in R 336.2033.

(6) Determinations of total gaseous nonmethane organic emissions as carbon, using the alternate version of federal reference test method 25 incorporating the Byron analysis, shall be conducted as specified in R 336.2006.

History: 1979 ACS 1, Eff. Jan. 19, 1980; 1985 MR 2, Eff. Feb. 22, 1985; 1989 MR 4, Eff. Apr. 19, 1989; 1993 MR 4, Eff. Apr. 28, 1993; 2002 MR 5, Eff. Mar. 19, 2002; 2006 MR 4, Eff. Feb. 22, 2006.

### **R 336.2005 Reference test methods for state-requested tests of delivery vessels.**

Rule 1005. The following reference test method shall be used to detect gasoline vapor leaks by a combustible gas detector:

(a) Principle. A combustible gas detector is used to indicate any incidence of leakage from gasoline delivery vessel tanks and vapor control systems. This qualitative monitoring procedure is an enforcement tool to confirm the continuing existence of leak-tight conditions.

(b) Applicability. This method is applicable to determining leak-tightness of gasoline delivery vessel tanks during loading without taking the delivery vessel tank out of service. The method is applicable only if the vapor control system does not create back pressure in excess of the pressure limits of the delivery vessel tank compliance leak test. For vapor control systems, this method is applicable to determining leak-tightness at any time.

(c) Apparatus and specifications. The following apparatus shall be used:

(i) Manometer. Liquid manometer, or equivalent, capable of measuring up to 0.9 pounds per square inch (24.9 inches of water) gauge pressure within 0.003 pounds per square inch (0.1 inches of water) precision.

(ii) Combustible gas detector. A portable hydrocarbon gas analyzer with associated sampling line and probe which complies with all of the following provisions:

(A) Safety. The device is certified as safe for operation in explosive atmospheres.

(B) Range. The device shall have a minimum range of 0 to 100% of the lower explosive limit (LEL) as propane.

(C) Probe diameter. The sampling probe shall have an internal diameter of 0.625 centimeters (1/4 inch).

(D) Probe length. The probe sampling line shall be of sufficient length for easy maneuverability during testing.

(E) Response time. The response time for full-scale deflection shall be less than 8 seconds for a detector with a sampling line and probe attached.

(d) Test procedure. The following test procedure shall be complied with:

(i) Pressure. Place a pressure tap in the terminal, plant, or service station vapor control system as close as possible to the connection with the delivery vessel tank. Record the pressure periodically during testing.

(ii) Calibration. Calibrate the combustible gas detector with 2.2% propane, by volume, in air for

100% lower explosive limit response.

(iii) Monitoring procedure. During loading or unloading, check the periphery of all potential sources of leakage of the delivery vessel tank and of the terminal, plant, or service station vapor collection system with a combustible gas detector. The check shall comply with the following procedure:

(A) Probe distance. The probe inlet shall be 2.5 centimeters from the potential leak source.

(B) Probe movement. Move the probe slowly (2.0 centimeters per second). If there is any meter deflection at a potential leak source, move the probe to locate the point of highest meter response.

(C) Probe position. As much as possible, the probe inlet shall be positioned in the path of (parallel to) the vapor flow from a leak.

(D) Wind. Attempt, as much as possible, to block the wind from the area being monitored.

(iv) Recording. Record the highest detector reading and location for each incidence of leakage.

History: 1979 ACS 7, Eff. Aug. 22, 1981; 1989 MR 4, Eff. Apr. 20, 1989; 2002 MR 5, Eff. Mar. 19, 2002; 2006 MR 4, Eff. Feb. 22, 2006.

### **R 336.2006 Reference test method serving as alternate version of federal reference test method 25 by incorporating Byron analysis.**

Rule 1006. When using the alternate version of federal reference test method 25 incorporating the Byron analysis, the procedures in method 25, which are described in R 336.2004, shall be followed, except that all of the following parts in method 25 are amended to read as follows:

- 1.2 Principle. An emission sample is withdrawn from a stack at a constant rate through a stainless steel absorber tube packed with porasil; the gaseous portion of the sample is pulled past a battery-operated sampling pump into a tedlar bag. After sampling is complete, the contents of the tedlar bag are analyzed on an automated gas chromatograph (GC), and the sample in the porasil packed tube is heated to remove all components for analysis on the GC. The GC separates CO, CO<sub>2</sub>, and CH<sub>4</sub> from the nonmethane organics (NMO), then converts the NMOs to methane for analysis.
2. Apparatus. The sampling system consists of a nonmethane organic (NMO) absorber tube, a sampling pump, and a sample bag (figure 25-1). The analytical system has 2 parts the oven for removing the sample from the absorber tube and an automated gas chromatograph (GC).
  - 2.1 Sampling. All of the following equipment is required, as shown in figure 25-1:
    - 2.1.1 Heated probe. 6.4-millimeter (mm) (1/4-inch (in.)) outside diameter (o.d.) stainless steel tubing with a heating system that is capable of maintaining a gas temperature at the exit end of not less than 129 degrees Centigrade (265 degrees Fahrenheit). The probe shall be equipped with a thermocouple at the exit end to monitor the gas temperature. The nozzle is an elbow fitting that is attached to the front end of the probe while the thermocouple is inserted in the side arm of a tee fitting that is attached to the rear of the probe. The probe is wrapped with a suitable length of high-temperature heating tape and then covered with 2 layers of glass cloth insulation and 1 layer of aluminum foil.

- 2.1.2 Heated prefilter-only for stacks with possible particulate matter interference. A stainless steel filter holder with a 47-mm type A/E fiberglass filter without organic binder. The entire prefilter shall be maintained at 110 degrees Celsius. Note - if it is not possible to use a heating system for safety reasons, an unheated system with an instack filter is a suitable alternative.
- 2.1.3 NMO absorber tube. 1/2-inch inside diameter (i.d.) stainless steel tube packed with porasil (thermally stable silica gel).
- 2.1.4 1/4-inch o.d. teflon line that is 2 to 4 feet long.
- 2.1.5 Battery-operated diaphragm sampling pump with kurz digital mass flow meter. Total flow is integrated electronically to measure flow with an accuracy of 1% at any flow rate. (Byron instruments model 90).
- 2.1.6 Sample bag. 0.3-mil tedlar, 1/2-cubic foot capacity. The sample bag undergoes nitrogen purge cycle until analysis exhibits zero carbon content in the sample bag.
- 2.2 Analysis. The following equipment is required:
  - 2.2.1 Sample recovery on the adsorber tube is done in a Byron model 75 oven in 2 stages, each stage requiring a 0.3-mil tedlar bag that has a 1/2-cubic foot capacity.
  - 2.2.2 Analysis is done on a Byron model 401 gas chromatograph (GC) that meets all criteria specified in method 25, section 2.2.2.
- 2.3 NMO analyzer. The NMO analyzer is a Byron model 401 gas chromatograph (GC). (Remainder of 2.3 as stated in method 25)
  - 2.3.5.2 Range. A full scale range of 1 to 10,000 parts per million (ppm) CH<sub>4</sub>. Signal attenuators shall be available to produce a minimum signal response of 10% of full scale.
- 3.1.1 Delete (dry ice is not required).
- 4.1.1 Model 90 and model 75 flow meter calibration. The model 90 sample pump inlet is attached to the outlet of the model 75 oven. Air is passed through the system at the rate that will be used in sampling and for the total volume anticipated to be sampled. If the flow meters on the 2 instruments do not agree within 0.01 liters, then adjust the meter on the model 90 until agreement is within 0.01 liters. After making any correction, run a full calibration again.
- 4.1.2 Sample train assembly. Assemble the probe (prefilter if needed), adsorber tube, and teflon line to the inlet of the model 90. Attach a short (8 to 10 inches) flexible line to the outlet of model 90. Have a completely clean evacuated tedlar sample bag nearby for collection of sample to be analyzed.
- 4.1.3 Pretest leak check. Stopper the inlet of the probe and place the flexible tube on the outlet of the model 90 in a small open container of water. Turn on the sampling pump. For a satisfactory leak check, bubbling should cease within 1 minute. If the leak check is unsatisfactory, tighten the fittings or change parts until a satisfactory leak check is obtained.

- 4.1.4 Sampling train operation. Place the probe and the front portion of the adsorption tube in the stack. If the stack has a temperature higher than ambient, allow time for the probe to heat before starting the sample pump. Start the model 90 pump and adjust to the desired flow, usually about 90 ml/min. After about 0.1 liter of sampling, or equivalent to the volume of air that is displaced in the sample system before the flowmeter, remove the flexible tube from the outlet of the model 90 and install the evacuated tedlar bag. This assures that gaseous components are undiluted by the air originally in the sampling system. Record requested data on the data form during the sample time. The sampling is usually done for 1 hour with a total of 5 to 6 liters sampled. When sampling is complete, record the precise volume sampled. The process may require different sample times or sample volumes. (Sampling form is figure 25-8.)
- 4.1.5 Post test leak check. Remove the tedlar bag and replace it with the flexible tube. Stopper the probe and operate the same as the pretest leak check specified in section 4.1.3. If the leak test is not acceptable, invalidate the sample.
- 4.2 Sample recovery. The tedlar bag is ready for direct analysis on the GC. The adsorber tube shall undergo the following 2-stage preparation:
- 4.2.1 Sample purge. The absorber tube is placed in the Byron model 75 oven with a clean tedlar bag attached directly to the tube. A volume of clean dry air is passed through the adsorber tube while holding the oven temperature at about 130 degrees Celsius. The volume of air should be precisely the same as that sampled. This purge is necessary to remove any CO<sub>2</sub> on the sample tube, and the elevated temperature is needed to assure CO<sub>2</sub> removal from any absorbed water. The tedlar bag is now ready for direct analysis on the GC.
- 4.2.2 Sample digest. The absorber tube, now free of CO<sub>2</sub> and the lighter NMOs, is now attached to an oxidation catalyst, and another tedlar bag is attached to the outlet of the oxidation catalyst. A volume of clean dry air equal to that sampled is passed through this system while the temperature on the sample tube is brought up to 600 degrees Celsius. If the sampled volume was less than 3 liters, a larger volume shall be used in the digestion to assure completion. Usually a multiple of precisely 1.5 or 2.0 of the sampled volume is sufficient. This third tedlar bag is now ready for direct analysis on the GC. If anything other than CO<sub>2</sub> is found in this bag, the model 75 oxidation catalyst is probably in need of replacement. In this case the test would be invalid and would have to be redone.
- 4.3 Analysis. Each of the 3 bags is analyzed on the GC. Each bag should be analyzed as soon as possible after being filled. At the completion of analysis, the bags shall be cleaned by repeated fillings with either clean air or nitrogen. Before being used again, the bags shall be checked by filling with clean air and then analyzed on the GC to assure zero concentrations of all analyzed substances. All pertinent calibration, performance, and operational checks in sections 4.4 and 5 of method 25 apply to the Byron system.
6. Calculations.
- 6.1 Nomenclature.
- C1 = Concentration of sample bag, ppm C, (NMO converted to methane).  
C2 = Concentration of purge bag, ppm C, (NMO converted to methane).  
C3 = Concentration of digest bag, ppm C, (CO<sub>2</sub> converted to methane).  
C = Ppm C (NMO).

6.2 – 6.4 (Delete).

6.5 C1, C2, C3 calculated directly as:

$$\frac{\text{ppm C calibration gas}}{\text{GC reading calibration gas}} \times \text{GC reading unknown} = \text{ppm C unknown}$$

6.6  $C = C1 + C2 + C3$

Delete figures 25.3, 25.4, 25.9, and 25.10 from method 25. Amend figures 25.1 and 25.8 from method 25 to read as follows:

Figure 25.1  
SAMPLING TRAIN

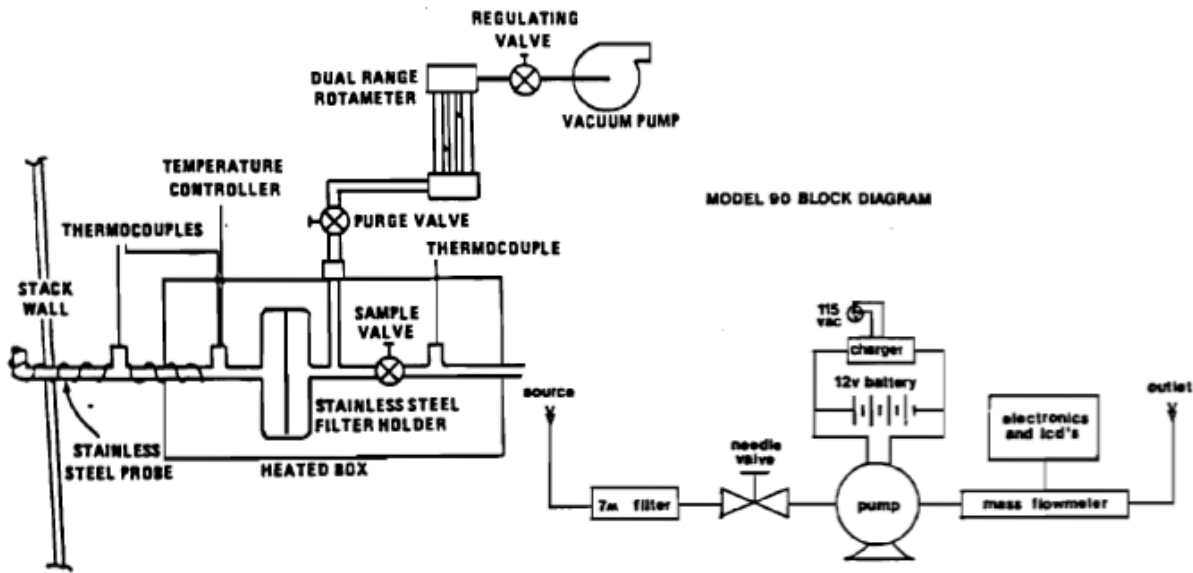



Figure 25.8  
EXAMPLE FIELD DATA FORM

Plant	Time Start	Time Stop	Temp Amb.	Temp Stack	Bag #	Filter #	Flow Rate	Leak Check
Source	Date	Bag PrePurge	Liter Sample	Liter Purge	Liter Digest	Operator		
Peak Values								
THC	NMHC	CH4	CO	CO2	Integrated Values			
THC	NMHC	CH4	CO	CO2	THC	NMHC	CH4	CO
THC	NMHC	CH4	CO	CO2	THC	NMHC	CH4	CO
SAMPLE								
BAG								
Range								
PURGE								
BAG								
Range								
DIGEST								
BAG								
Range								

History: 1993 MR 4, Eff. Apr. 28, 1993.

**R 336.2007 Alternate version of procedure L, referenced in R 336.2040(10).**

Rule 1007. (1) The alternate version of procedure L is as follows:

1. Introduction.
  - 1.1 Applicability. This procedure is applicable for determining the input of volatile organic compounds (voc), measured as equivalent propane as measured by a flame ionization instrument. It is intended to be used as a segment in the development of liquid/gas protocols for determining voc capture efficiency (ce) for surface coating and printing operations.
  - 1.2 Principle. The amount of voc introduced to the process (I) is the sum of products of the weight (w) of each voc containing liquid (ink, paint, solvent, or similar material) used and its voc content (v), corrected for a response factor (rf) to allow the input to be calculated in terms of propane, the same calibration gas used in the gaseous voc measurements. A sample of each coating used is distilled to separate the voc fraction. The distillate is used to prepare a known standard for analysis by a flame ionization analyzer (fia), calibrated against propane, to determine its rf
2. Apparatus and reagents.
  - 2.1 Liquid weight.
    - 2.1.1 Balances/digital scales. To weigh drums of voc containing liquids to within 0.2 lb.
    - 2.1.2 Volume measurement apparatus (alternative). Volume meters, flow meters, density measurement equipment, or similar material, as needed to achieve the same accuracy as direct weight measurements.
  - 2.2 Response factor (rf) determination (fia technique). The voc distillation and tedlar gas bag generation systems apparatus are shown in figures 1 and 2. The following equipment is required:
    - 2.2.1 Sample collection can. An appropriately sized metal can to collect voc-containing materials. The can shall be constructed in such a way that it can be grounded to the coating container.
    - 2.2.2 Needle valves. To control gas flow.
    - 2.2.3 Regulators. For fia, calibration, dilution, and sweep gas cylinders.
    - 2.2.4 Tubing and fittings. Teflon and stainless steel tubing and fittings with diameters and lengths and sizes determined by connection requirements of the equipment.
    - 2.2.5 Thermometer. Capable of measuring the temperature of the hot water and oil baths to within 1 degree Celsius.
    - 2.2.6 Analytical balance. To measure plus or minus 0.01 mg.
    - 2.2.7 Microliter syringe. 10-microliter size.
    - 2.2.8 Vacuum and pressure manometers. 0 to 760 mm (0 to 30 in.) hg. U-tube manometer, vacuum or pressure.
    - 2.2.9 Hot oil bath, with stirring hot plate. Capable of heating and maintaining a distillation vessel at 110 plus or minus 3 degrees Celsius.
    - 2.2.10 Vacuum/water aspirator. A device capable of drawing a vacuum to within 20 mm hg from absolute.
    - 2.2.11 Rotary evaporator system. Complete with folded inner coil, vertical style condenser, rotary speed control, and teflon sweep gas delivery tube with valved inlet. Buchi rotavapor or equivalent.

- 2.2.12 Ethylene glycol cooling/circulating bath. Capable of maintaining the condenser coil fluid at minus 10 degrees Celsius.
- 2.2.13 Dry gas meter. For the precise measurement of dilution gas volume. It shall be calibrated to a primary standard, either spirometer or bubble meter.
- 2.2.14 Activated charcoal/mole sieve trap. To remove any trace level of organics picked up from the dry gas meter.
- 2.2.15 Gas coil heater. Sufficient length of 0.125-inch stainless steel tubing to allow heating of the dilution gas to near the water bath temperature before entering the volatilization vessel.
- 2.2.16 Water bath, with stirring hot plate. Capable of heating and maintaining a volatilization vessel and coil heater at a temperature of 100 plus or minus 5 degrees Celsius.
- 2.2.17 Volatilization vessel. 50-milliliter midget impinger fitted with a septum top and loosely filled with glass wool to increase volatilization surface.
- 2.2.18 Tedlar gas bag. Capable of holding 30 liters of gas, flushed clean with zero air, leak tested and evacuated.
- 2.2.19 Cylinder of compressed zero air. Used to supply dilution air for making the tedlar bag gas samples.
- 2.2.20 Cylinder of compressed the free n<sub>2</sub>. Used as sweep gas in the rotary evaporator system.
- 2.2.21 Organic concentration analyzer. An fia with a span value of 1.5 times the expected concentration as propane; however, other span values may be used if it can be demonstrated that they would provide more accurate measurements. The fia instrument shall be the same instrument used in the gaseous analyses adjusted with the same fuel, combustion air, and sample backpressure (flowrate) settings. The system shall be capable of meeting or exceeding the following specifications:
  - 2.2.21.1 Zero drift. Less than plus or minus 3.0% of the span value.
  - 2.2.21.2 Calibration drift. Less than plus or minus 3.0% of span value.
  - 2.2.21.3 Calibration error. Less than plus or minus 5.0% of the calibration gas value.
- 2.2.22 Integrator/data acquisition system. An analog or digital device or computerized data acquisition system used to integrate the fia response or compute the average response and record measurement data. The minimum data sampling frequency for computing average or integrated values is 1 measurement value every 5 seconds. The device shall be capable of recording average values at least once per minute.
- 2.2.23 Chart recorder (optional). A chart recorder or similar device is recommended to provide a continuous analog display of the measurement results during the liquid sample analysis.

- 2.2.24 Calibration and other gases. For calibration, fuel, and combustion air, if required, contained in compressed gas cylinders. All calibration gases shall be traceable to NIST standards and shall be certified by the manufacturer to plus or minus 1% of the tag value. Additionally, the manufacturer of the cylinder should provide a recommended shelf life for each calibration gas cylinder over which the concentration does not change more than plus or minus 2% from the certified value. For calibration gas values that are not generally available, alternative methods for preparing calibration gas mixtures, such as dilution systems, may be used with prior approval.
- 2.2.24.1 Fuel. 99.995% hydrogen, 40% hydrogen/60% helium, or 40% hydrogen/ 60% nitrogen. The fia manufacturer's recommended fuel shall be used. An attempt shall be made to avoid fuels with oxygen to avoid an oxygen synergism effect that reportedly occurs when oxygen concentration varies significantly from a mean value.
- 2.2.24.2 Carrier gas. High purity air with less than 1 ppm of organic material (as propane) or less than 0.1% of the span value, whichever is greater.
- 2.2.24.3 Fia linearity calibration gases. Low-, mid-, and high-range gas mixture standards with a nominal propane concentration of 20 to 30, 45 to 55, and 70 to 80% of the span value in air, respectively. Other calibration values and other span values may be used if it can be shown that more accurate measurements would be achieved.
- 2.2.24.4 System calibration gas. Gas mixture standard which contains propane in air and which approximates the voc concentration expected for the tedlar gas bag samples.
3. Determination of liquid input weight. A capture efficiency test shall consist of not less than 3 sampling runs. Each run shall cover at least 1 complete production or processing cycle or shall be at least 1 hour in duration. For automotive surface coating operations, the sampling time per run shall be based on coating a minimum of 3 representative vehicles.
- 3.1 Weight difference. Determine the amount of material introduced to the process as the weight difference of the feed material before and after each sampling run. In determining the total voc-containing liquid usage, account for all of the following:
- (a) The initial (beginning) voc-containing liquid mixture.
  - (b) Any solvent added during the test run.
  - (c) Any coating added during the test run.
  - (d) Any residual voc-containing liquid mixture remaining at the end of the sample run.
- 3.1.1 Identify all points where voc-containing liquids are introduced to the process. To obtain an accurate measurement of voc- containing liquids, start with an empty fountain, if applicable. After completing the run, drain the liquid in the fountain back into the liquid drum, if possible, and weigh the drum again. Weigh the voc-containing liquids to plus or minus 0.5% of the total weight (full) or plus or minus 0.1% of the total weight of voc-containing liquid used during the sample run, whichever is less. If the residual liquid cannot be returned to the drum, drain the fountain into a preweighed empty drum to determine the final weight of the liquid.

- 3.1.2 If it is not possible to measure a single representative mixture, then weigh the various components separately, for example, if solvent is added during the sampling run, weigh the solvent before it is added to the mixture. If a fresh drum of voc-containing liquid is needed during the run, then weigh both the empty drum and the fresh drum.
- 3.2 Volume measurement (alternative). If direct weight measurements are not feasible, the tester may use volume meters, flow rate meters, and density measurements to determine the weight of liquids that are used if it can be demonstrated that the technique produces results equivalent to the direct weight measurements. If a single representative mixture cannot be measured, measure the components separately.
- 4. Determination of voc content in input liquids.
  - 4.1 Collection of liquid samples.
    - 4.1.1 Collect a 1-pint or larger sample of the voc-containing liquid mixture at each application location at the beginning and end of each test run. A separate sample shall be taken of each voc-containing liquid that is added to the application mixture during the test run. If a fresh drum is needed during the sampling run, then obtain a sample from the fresh drum.
    - 4.1.2 When collecting the sample, ground the sample container to the coating drum. Fill the sample container as close to the rim as possible to minimize the amount of headspace.
    - 4.1.3 After the sample is collected, seal the container so the sample cannot leak out or evaporate.
    - 4.1.4 Label the container to identify clearly the contents.
  - 4.2 Distillation of voc.
    - 4.2.1 Assemble the rotary evaporator as shown in figure 1.
    - 4.2.2 Leak check the rotary evaporation system by aspirating a vacuum of approximately 20 mm hg from absolute. Close up the system and monitor the vacuum for approximately 1 minute. If the vacuum falls more than 125 mm hg in 1 minute, repair leaks and repeat.
    - 4.2.3 Deposit approximately 20 mls of the sample (inks, paints, or similar material) into the rotary evaporation distillation vessel.
    - 4.2.4 Turn off the aspirator and gradually apply a vacuum to the evaporator of within 20 mm hg.
    - 4.2.5 Begin heating the vessel at a rate of 2 to 3 degrees Centigrade per minute, maintaining the vacuum specified in 4.2.3. Care shall be taken to prevent material bumping from the distillation flask.
    - 4.2.6 Continue heating until a temperature of 110 degrees Centigrade is achieved and maintain this temperature for not less than 10 minutes or until the sample has dried in the distillation flask.
    - 4.2.7 Slowly introduce the n2 sweep gas through the purge tube and into the distillation flask, taking care to maintain not less than 125 mm hg vacuum at all times.
    - 4.2.8 Continue sweeping the remaining solvent voc from the distillation flask and condenser assembly for 10 minutes or until all traces of condensed solvent are gone from the vessel and the still head.

- 4.2.9 Disassemble the apparatus and transfer the distillate to a labeled sealed vial.
- 4.3 Preparation of voc standard bag sample.
  - 4.3.1 Assemble the bag sample generation system as shown in figure 2 and bring the water bath up to a near-boiling temperature.
  - 4.3.2 Inflate the tedlar bag and perform a leak check on the bag.
  - 4.3.3 Evacuate the bag and close the bag inlet valve.
  - 4.3.4 Record the current barometric pressure.
  - 4.3.5 Record the starting reading on the dry gas meter, open the bag inlet valve, and start the dilution zero air flowing into the tedlar bag at approximately 2 liters per minute.
  - 4.3.6 The bag sample voc concentration shall be similar to the gaseous voc concentration measured in the exhaust gas ducts. The amount of liquid voc required can be approximated using the equations in section 6, the gaseous voc measurement results in terms of propane, and an assumed response factor of 1.0. Let  $c_{c3}$  equal the exhaust gas concentration in terms of propane and  $rf=1.0$ . Calculate  $c_{voc}$ . Let  $b_v = 20$  liters and calculate  $m_1$ , the approximate quantity of liquid to be used to prepare the bag gas sample.
  - 4.3.7 Quickly withdraw an aliquot (approximately 5 microliters) of sample from the distillate vial with the microliter syringe and record its weight from the analytical balance to the nearest 0.01 Mg.
  - 4.3.8 Inject the contents of the syringe through the septum of the volatilization vessel into the glass wool inside the vessel.
  - 4.3.9 Reweigh and record the tare weight of the now empty syringe.
  - 4.3.10 Record the pressure and temperature of the dilution gas as it is passed through the dry gas meter, as shown in the figure 2 diagram.
  - 4.3.11 After approximately 20 liters of dilution gas have passed into the tedlar bag, close the valve to the dilution air source and record the exact final reading on the dry gas meter.
  - 4.3.12 The gas bag is then analyzed by fia within 1 hour of bag preparation in accordance with the procedures contained in section 4.4.
- 4.4 Determination of voc response factor.
  - 4.4.1 Start up the fia instrument using the same settings as used for the gaseous voc measurements.
  - 4.4.2 Perform the fia analyzer calibration and linearity checks according to the procedure in section 5.1. Record the responses to each of the calibration gases and the back-pressure setting of the fia.
  - 4.4.3 Connect the tedlar bag sample to the fia sample inlet and record the bag concentration in terms of propane. Continue the analysis until a steady reading is obtained for not less than 30 seconds. Record the final reading and proceed with the calculation of the response factor.
- 4.5 Determination of coating voc content as voc ( $v_u$ ).
  - 4.5.1 Determine the voc content of the coatings used in the process using EPA method 24 or 24a as applicable.
- 5. Calibration and quality assurance.

- 5.1 Fia calibration and linearity check. Make necessary adjustments to the air and fuel supplies for the fia and ignite the burner. Allow the fia to warm up for the period recommended by the manufacturer. Inject a calibration gas into the measurement system and adjust the back-pressure regulator to the value required to achieve the flow rates specified by the manufacturer. Inject the zero- and the high-range calibration gases and adjust the analyzer calibration to provide the proper responses. Inject the low- and mid-range gases and record the responses of the measurement system. The calibration and linearity of the system are acceptable if the responses for all 4 gases are within 5% of the respective gas values. If the performance of the system is not acceptable, repair or adjust the system and repeat the linearity check. Conduct a calibration and linearity check after assembling the analysis system and after a major change is made to the system. A calibration curve consisting of zero gas and 2 calibration levels shall be performed at the beginning and end of each batch of samples.
- 5.2 Systems drift checks. After each sample, repeat the system calibration checks in section 5.1 before any adjustments to the fia or measurement system are made. If the zero or calibration drift is more than plus or minus 3% of the span value, discard the result and repeat the analysis.
- 5.3 Quality control. A minimum of 1 sample in each batch shall be distilled and analyzed in duplicate as a precision control. If the results of the 2 analyzed differ by more than plus or minus 10% of the mean, then the system shall be reevaluated and the entire batch shall be redistilled and analyzed.

6. Calculations.

- 6.1 Bag sample volume,  $B_v$ .

$$B_v = \frac{(M_v)(T_{STD})(P_M)}{(T_M)(P_{STD})}$$

Where:

$B_v$  = Bag sample volume in standard liters.

$M_v$  = Indicated dry gas meter volume, in liters.

$T_{STD}$  = 293<sup>0</sup>K.

$T_M$  = Meter gas temperature, in <sup>0</sup>K.

$P_M$  = Meter gas pressure, in mm Hg absolute.

$P_{STD}$  = 760 mm Hg.

- 6.2 Bag sample voc concentration, as voc,  $C_{voc}$ .

$$C_{voc} = M_1/B_v$$

Where:

$C_{voc}$  = Bag sample voc concentration, as voc, mg/std. liters.

$M_1$  = Weight of voc liquid injected, mg.

- 6.3 Bag sample voc concentration, as propane,  $C_{c3}$ .

$$C_{c3} = R_{c3} * K$$

Where:

$C_{c3}$  = Bag sample voc concentration, as propane, mg C<sub>3</sub>/std. liter.

$R_{c3}$  = FIA reading for bag gas sample, ppm propane.

$K$  = Conversion factor, 0.00183  $\frac{\text{mg. propane/ std. liter.}}{\text{ppm propane}}$

6.4 Response factor, RF.

$$RF = C_{voc}/C_{c3}$$

Where:

RF = Response factor, weight voc/weight propane.

6.5 Total voc content of the input voc containing liquid, as propane, L.

$$L = \sum_{j=1}^n \frac{V_{IJ}W_{IJ}}{RF_j} - \sum_{j=1}^n \frac{V_{FJ}W_{FJ}}{RF_j} + \sum_{j=1}^n \frac{V_{AJ}W_{AJ}}{RF_j}$$

Where:

L = Total voc content of liquid input, calculate as propane, kg.

V<sub>IJ</sub> = Initial voc weight fraction of voc liquid J.

V<sub>FJ</sub> = Final voc weight fraction of voc liquid J.

V<sub>AJ</sub> = Voc weight fraction of voc liquid J added during the test.

W<sub>IJ</sub> = Weight of voc containing liquid J at beginning of test, kg.

W<sub>FG</sub> = Weight of voc containing liquid J at end of test, kg.

W<sub>AJ</sub> = Weight of voc containing liquid J added during the test, kg.

RF<sub>J</sub> = Response factor for voc in liquid J, weight voc/weight propane.

FIGURE 1. VOC Distillation Apparatus  
Paint Solvent Distillation Schematic

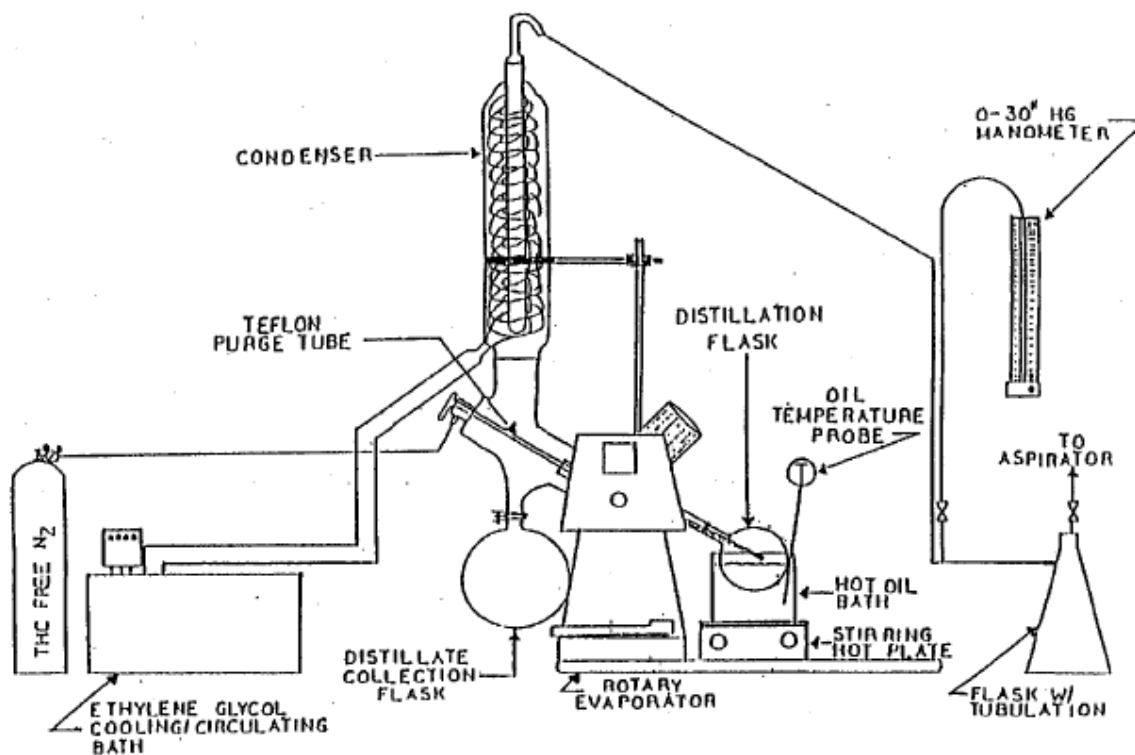
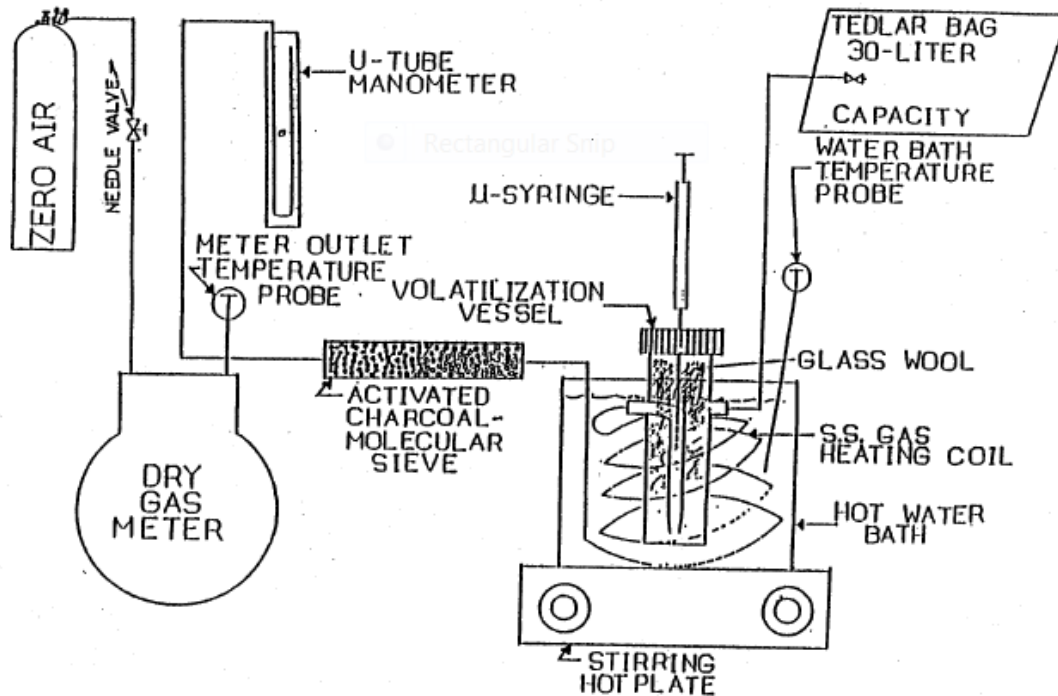



FIGURE 2. Bag Sample Generation System



Sample Preparation Equipment Schematic  
Response Factor Determination Procedure

History: 1993 MR 4, Eff. Apr. 28, 1993; 2002 MR 5, Eff. Mar. 19, 2002.

**R 336.2011 Reference test method 5B.**

Rule 1011. Reference test method 5B, in-stack filtration method, reads as follows:

(a) The principle, applicability, and performance test criteria are as follows:

(i) Principle. Particulate matter is withdrawn isokinetically from the source and collected on solid filtering media maintained at stack temperature. The particulate matter mass is determined gravimetrically after removal of uncombined water.

(ii) Applicability. This method is applicable for the determination of particulate emissions from stationary sources as identified in table 31 of R 336.1331. The method is also applicable when specifically provided for in the department's rules, orders, a permit to install, or a permit to operate.

(iii) Performance test criteria:

(A) A performance test shall consist of a minimum of 3 separate samples of a specific air contaminant conducted within a 36-hour period, unless otherwise authorized by the department. Each of the 3 separate samples shall be obtained while the source is operating at a similar production level. For the purpose of determining compliance with an applicable emission limit, rule, or permit condition, the arithmetic mean of results of the 3 samples shall apply. If a sample is accidentally lost or conditions occur in which 1 of the 3 samples must be discontinued because of forced shutdown, failure of an

irreplaceable portion of the sampling train, extreme meteorological conditions, or other circumstances beyond the owner's or operator's control, compliance may, upon the approval of the department, be determined using the arithmetic mean of the results of 2 samples.

(B) For any source that is subject to an emission limitation calculated to 50% excess air, the multipoint, integrated sampling procedure of R 336.2004(1)(c) shall be used for gas analysis. For all other sources that require a determination of the molecular weight of the exhaust, any optional sampling procedure of R 336.2004(1)(c) may be used. Alternatives or modifications to procedures are subject to the approval of the department.

(C) The minimum volume per sample shall be 30 cubic feet of dry gas corrected to standard conditions (70 degrees Fahrenheit, 29.92 inches mercury). Minimum sample time shall be 60 minutes, which may be continuous or a combination of shorter sampling periods for sources that operate in a cyclic manner. Smaller sampling times or sample volumes, if necessitated by process variables or other factors, may be approved by the department.

(D) For any source whose emission control device alters the moisture content of the exhaust gas, a moisture determination shall be performed in a location upstream from the emission control device and in accordance with R 336.2004(1)(d) or an alternative method approved by the department.

(b) The following provisions apply to apparatus:

(i) Sampling train. A schematic of the sampling train used in this method is shown in figure 102. Construction details for many, but not all, of the train components are given in APTD-0581. (See subdivision (g)(ii) of this rule.) For changes from the APTD-0581 document and for allowable modifications to figure 102, the user shall consult with the department.

The operating and maintenance procedures for many, but not all, of the sampling train are described in APTD-0576. (See subdivision (g)(iii) of this rule.) Since correct usage is important in obtaining valid results, all users shall read APTD-0576 and adopt the applicable operating and maintenance procedures outlined in it, unless otherwise specified herein. The sampling train shall consist of the following components:

(A) Probe nozzle. Stainless steel (316) or glass with sharp, tapered leading edge. The angle of taper shall be less than 30 degrees and the taper shall be on the outside to preserve a constant internal diameter. The probe nozzle shall be of the button-hook design, unless otherwise specified by the department. If made of stainless steel, the nozzle shall be constructed from seamless tubing. Other materials of construction may be used, subject to the approval of the department.

A range of nozzle sizes suitable for isokinetic sampling shall be available, for example, 0.32 to 1.27 cm (1/8 to 1/2 in. - or larger if higher volume sampling trains are used - inside diameter (ID) nozzles in increments of 0.16 cm (1/16 in.). Each nozzle shall be calibrated according to the procedures outlined in subdivision (e) of this rule.

(B) Probe liner. Interior surface may be constructed of stainless steel (no specific grade), glass, teflon, or such other material that maintains proper flow at the stack conditions experienced.

(C) Pitot tube. Type S, as described in section 2.1 of method 2, or other device approved by the department. The pitot tube shall be attached to the probe, as shown in figure 102, to allow constant monitoring of the stack gas velocity. The impact (high pressure) opening plane of the pitot tube shall be even with or above the nozzle entry plane (see method 2, figure 2-6b) during sampling. The type S pitot tube assembly shall have a known coefficient, determined as outlined in section 4 of method 2.

(D) Differential pressure gauge. Incline manometer or equivalent devices (2) as described in section 2.2 of method 2. One manometer shall be used for velocity head (p) readings and the other shall be used for orifice differential pressure readings.

(E) Filter holders. Two separate filter holders in series or 1 filter holder with separate filter supports and seals for 2 filters. One filter holder with 2 filters held in contact with each other is not acceptable. Materials of construction may be stainless steel (316), glass, teflon, or other material approved by the department.

(F) Filter heating system. Auxiliary heating of the filter media is not acceptable. For saturated stack gases, the operator may opt to use filters that do not blind when wet and that do not require heating (see subdivision (c)(i)(A) of this rule).

(G) Condenser. The following system shall be used to determine the stack gas moisture content: Three impingers connected in series with leak-free ground glass fittings or any similar leak-free noncontaminating fittings. All impingers shall be of the Greenburg-Smith design and shall be modified by replacing the tip with a 1.3 cm (1/2 in.) ID glass tube extending to about 1.3 cm (1/2 in.) from the bottom of the flask. Modifications, such as using flexible connections between the impingers or using materials other than glass, are permitted, subject to the approval of the department. The first impinger shall contain a known quantity of water (subdivision (d)(i)(C) of this rule); the second shall be empty; and the third shall contain a known weight of silica gel or equivalent desiccant.

Alternatively, any system that cools the sample gas stream and allows measurement of the water condensed and moisture leaving the condenser, each to within 1 ml or 1 g, may be used, subject to the approval of the department. In any case, the means for measuring the moisture leaving the condenser shall be by passing the sample gas stream through a tared silica gel, or equivalent desiccant, trap with exit gases kept below 20 degrees Centigrade (68 degrees Fahrenheit) and determining the weight gain.

If a determination of the particulate matter collected in the impingers is required by the department's rules, a permit to install, or a permit to operate, then the impinger system described above shall be used without modification. Contact the department as to the sample recovery and analysis of the impinger contents.

(H) Metering system. Vacuum gauge, leak-free pump, thermometers capable of measuring temperature to within 3 degrees Centigrade (5.4 degrees Fahrenheit), dry-gas meter capable of measuring volume to within 2%, and related equipment as shown in figure 102. Other metering systems capable of maintaining sampling rates within 10% of isokinetic and capable of determining sample volumes to within 2% may be used, subject to the approval of the department. When the metering system is used in conjunction with a pitot tube, the system shall enable checks of isokinetic rates.

Sampling trains utilizing metering systems designed for higher flow rates than those described in APTD-0581 or APTD-0576 may be used if the specifications of this method are met.

(I) Barometer. Mercury, aneroid, or other barometer capable of measuring atmospheric pressure to within 2.5 mm Hg (0.1 in. Hg). In many cases, the barometric reading may be obtained from a nearby national weather service station. In this case, the station value, which is the absolute barometric pressure, shall be requested and an adjustment for elevation differences between the weather station and sampling point shall be applied at a rate of minus 2.5 mm Hg (0.1 in. Hg) per 30 M (100 ft.) elevation increase or vice versa for elevation decrease.

(J) Gas density determination equipment. Temperature sensor and pressure gauge, as described in sections 2.3 and 2.4 of method 2, and gas analyzer, if necessary, as described in method 3. The temperature sensor shall, preferably, be permanently attached to the pitot tube or sampling probe in a fixed configuration such that the tip of the sensor extends beyond the leading edge of the probe sheath and does not touch any metal. Alternatively, the sensor may be attached just before use in the field. If the temperature sensor is attached in the field, then the sensor shall be placed in an interference-free arrangement with respect to the type S pitot tube openings (see method 2, figure 2-7). As a second alternative, if a difference of not more than 1% in the average velocity measurement is to be introduced, then the temperature gauge need not be attached to the probe or pitot tube. This alternative is subject to the approval of the department.

“Construction Details of Isokinetic Source Sampling Equipment,” APTD-0581, April 1971 (PB203-060-LL), and “Maintenance, Calibration, and Operation of Isokinetic Source Sampling Equipment,” APTD-0576, March 1972 (PB209-022-LL), are adopted by reference in this rule. Copies of these documents may be inspected at the Lansing office of the air quality division of the department of environmental quality. Copies of APTD-0581 and APTD-0576 may be obtained from the Department of

Environmental Quality, Air Quality Division, P.O. Box 30260, Lansing, Michigan 48909-7760, or from the National Technical Information Service, U.S. Department of Commerce, 5285 Port Royal Road, Springfield, Virginia 22161, at a cost at the time of adoption of these rules of \$28.50 each.

(ii) Sample recovery. The following items are required:

(A) Probe-liner and probe-nozzle brushes. Nylon bristle brushes with stainless steel wire handles. The probe brush shall have extensions, at least as long as the probe, made of stainless steel, nylon, teflon, or similarly inert material. The brushes shall be properly sized and shaped to brush out the probe liner and nozzle.

(B) Wash bottles -- 2. Glass wash bottles are recommended; the tester may use polyethylene wash bottles, but the acetone should not be stored in polyethylene bottles for longer than 1 month.

(C) Glass sample storage containers. Chemically resistant, borosilicate glass bottles for acetone washes, 500 ml or 1000 ml. Screw cap liners shall either be rubber-backed teflon or shall be constructed so as to be leak-free and resistant to chemical attack by acetone. Narrow-mouth glass bottles are less prone to leakage. Alternatively, polyethylene bottles may be used.

(D) Filter containers. Glass, polyethylene, or aluminum tube containers, unless otherwise specified by the department.

(E) Graduated cylinder or balance. To measure condensed water to within 1 ml or 1 g., graduated cylinders shall have subdivisions of not more than 2 ml. Most laboratory balances are capable of weighing to the nearest 0.5 g or less. Any of these balances may be used here and in paragraph (iii)(D) of this subdivision.

(F) Plastic storage containers. Airtight containers to store silica gel.

(G) Funnel and rubber policeman. To aid in the transfer of silica gel to container; not necessary if silica gel is weighed in the field.

(H) Funnel. Glass or polyethylene, to aid in sample recovery.

(iii) Analysis. The following equipment is required for analysis:

(A) Glass weighing dishes.

(B) Desiccator.

(C) Analytical balance. To measure to within 0.1 mg.

(D) Balance. To measure to within 0.5 mg.

(E) Beakers. 250 ml.

(F) Hygrometer. To measure the relative humidity of the laboratory environment.

(G) Temperature gauge. To measure the temperature of the laboratory environment.

(c) The following provisions shall apply to reagents:

(i) Sampling. The reagents used in sampling are as follows:

(A) Filters. Two in-stack filters may be any combination of alundum ceramic thimble filters, type RA-98, or glass fiber filters, type A without organic binder. The size of such filters shall allow proper sampling rates to maintain isokinetics using the nozzle sizes specified in subdivision (b)(i)(A) of this rule.

Alternatively, other types of filters may be used, subject to the approval of the department.

(B) Silica gel. Indicating type, 6 to 16 mesh. If previously used, dry at 175 degrees Centigrade (350 degrees Fahrenheit) for 2 hours. New silica gel may be used as received. Alternatively, other types of desiccants that are equivalent or better may be used, subject to the approval of the department.

(C) Water. When analysis of the material caught in the impingers is required, distilled water shall be used. Run blanks before field use to eliminate a high blank of test samples.

(D) Crushed ice.

(E) Stopcock grease. Acetone-insoluble, heat-stable silicone grease. This is not necessary if screw-on connectors with teflon sleeves, or equivalent, are used. Alternatively, other types of stopcock grease may be used, subject to the approval of the department.

(ii) Sample recovery. Washing solvent. Either acetone or distilled water may be used for sample

recovery. If acetone is used for washing solvent, then reagent grade, less than 0.001% residue, in glass bottles is required. Acetone from metal containers generally has a high residue blank and shall not be used.

If suppliers transfer acetone to glass bottles from metal containers, then acetone blanks shall be run before field use and only acetone with low blank values (less than 0.001%) shall be used. In no case shall a blank value of more than 0.001% of the weight of acetone used be subtracted from the sample weight.

If distilled water is used for washing solvent, use distilled water with less than 0.001% residue. Run blanks before field use to eliminate a high blank on test samples.

(iii) Analysis. Two reagents are required for the analysis:

(A) Solvent. Same as paragraph (ii) of this subdivision for quantitative transfer.

(B) Desiccant. Anhydrous calcium sulfate, indicating type. Alternatively, other types of desiccants may be used, subject to the approval of the department.

(d) The following provisions shall apply to procedure:

(i) Sampling. The complexity of this method is such that, in order to obtain reliable results, testers shall be trained and experienced with the test procedures. Sampling shall comply with the following provisions:

(A) Pretest preparation. All the components shall be maintained and calibrated according to the applicable procedures described in APTD-0576, unless otherwise specified in this rule.

Weigh several 200 to 300 g portions of silica gel in airtight containers to the nearest 0.5 g. Record the total weight of the silica gel plus container on each container. As an alternative, the silica gel need not be preweighed, but may be weighed directly in its impinger or sampling holder just before train assembly.

Check filters visually against light for irregularities, flaws, pinhole leaks, or cracks. Label filters of the proper size on the back side using numbering machine ink. As an alternative, label the shipping containers (subdivision (b)(ii)(D) of this rule) and keep the filters in these containers at all times, except during sampling and weighing.

Dry the filters in an oven at 105 degrees Centigrade (220 degrees Fahrenheit) for a minimum of 2 hours, cool for at least 1 hour in a desiccator containing anhydrous calcium sulfate, and individually weigh and record their weights to the nearest 0.1 mg. During the weighing, the filter shall not be exposed to the laboratory atmosphere for a period of more than 2 minutes and a relative humidity above 50%. Procedures, other than those specified, that account for relative humidity effects may be used, subject to the approval of the department.

(B) Preliminary determinations. Select the sampling site and the minimum number of sampling points according to method 1 or as specified by the department. Determine the stack pressure, temperature, and the range of velocity heads using method 2; it is recommended that a leak check of the pitot lines (see method 2, section 3.1) be performed. Determine the moisture content using approximation method 4, or its alternatives, for the purpose of making isokinetic sampling rate settings. Determine the stack gas dry molecular weight, as described in method 2, section 3.6; if integrated method 3 sampling is used for molecular weight determination, the integrated bag sample shall be taken simultaneously with, and for the same total length of time as, the particulate sample run.

Select a nozzle size based on the range of velocity heads so that it is not necessary to change the nozzle size to maintain isokinetic sampling rates. During the run, do not change the nozzle size. Ensure that the proper differential pressure gauge is chosen for the range of velocity heads encountered (see section 2.2 of method 2).

Select a suitable probe liner and probe length so that all traverse points may be sampled. For large stacks, sampling from opposite sides of the stack may reduce the length of probes.

Select a total sampling time greater than or equal to the minimum total sampling time specified in the department's rules so that the sampling time per point is not less than 5 minutes, unless approved by

the department, or some greater time interval as specified by the department, and so that the sample volume taken, corrected to standard conditions, exceeds the required minimum total gas sample volume. The latter is based on an approximate average sampling rate.

The number of minutes sampled at each point may be an integer or an integer plus 1/2 minute to avoid timekeeping errors.

In some circumstances, such as in batch cycles, it may be necessary to sample for shorter times at the traverse points and to obtain smaller gas sample volumes. In these cases, the department's approval shall first be obtained.

(C) Preparation of collection train. During preparation and assembly of the sampling train, keep all openings where contamination can occur covered until just before assembly or until sampling is about to begin.

Place 100 ml of water in the first impinger, leave the second impinger empty, and transfer approximately 200 to 300 g of preweighed silica gel from its container to the third impinger. More silica gel may be used, but care shall be taken to ensure that it is not entrained and carried out from the impinger during sampling. Place the container in a clean place for later use in the sample recovery. Alternatively, the weight of the silica gel plus impinger may be determined to the nearest 0.5 g and recorded.

Using tweezers or clean disposable surgical gloves, place a labeled (identified) and weighed filter in each filter holder. Be sure that the filter is properly centered and the gasket properly placed so as to prevent the sample gas stream from circumventing the filter.

Install the selected nozzle using a Viton A O-ring when stack temperatures are less than 260 degrees Centigrade (500 degrees Fahrenheit) and an asbestos string gasket when temperatures are higher. See APTD-0576 for requirements. Other connecting systems using either 310 stainless steel or teflon ferrules may be used to form a leak-free direct mechanical connection. Mark the probe with heat-resistant tape or by some other method to denote the proper distance into the stack or duct for each sampling point.

Set up the train as in figure 102. If necessary, use a very light coat of silicone grease on all ground glass joints. Grease only the outer portion (see APTD-0576) to avoid the possibility of contamination by the silicone grease. Place crushed ice around the impingers.

(D) Leak check procedures:

(1) Pretest leak check. A pretest leak check is strongly recommended, but not required, to prevent invalid sampling and wasted time. If the tester opts to conduct the pretest leak check, the following procedure shall be used:

Perform the leak check on the entire system, including filter housings and nozzle, by plugging the nozzle and pulling a 380 mm Hg (15 in. Hg) vacuum. Alternatively, a lower vacuum may be used if it is not exceeded during the test. Leakage rates in excess of 4% of the average sampling rate or 0.00057 m<sup>3</sup>/min (0.02 cfm), whichever is less, are unacceptable.

The following leak check instructions for the sampling train described in APTD-0576 and APTD-0581 may be helpful. Start the pump with the bypass valve fully open and the coarse adjust valve completely closed. Partially open the coarse adjust valve and slowly close the bypass valve until the desired vacuum is reached. Do not reverse the direction of the bypass valve; this will cause water to back up into the flexible sample tube and the probe. If the desired vacuum is exceeded, either leak-check at this higher vacuum or end the leak check and start over.

When the leak check is completed, first slowly remove the plug from the inlet to the nozzle and immediately turn off the vacuum pump. This prevents the water in the first impinger from being forced backward into the sample tube and prevents silica gel from being entrained backward into the second impinger.

(2) Leak checks during sample run. If, during the sampling run, a component (such as a filter assembly or impinger) change becomes necessary, a leak check shall be conducted immediately before

the change is made. The leak check shall be done according to the procedure outlined in paragraph (i)(D)(1) of this subdivision, except that it shall be done at a vacuum equal to or greater than the maximum value recorded up to that point in the test. If the leakage rate is not more than 0.00057 m<sup>3</sup>/min (0.02 cfm) or 4% of the average sampling rate, whichever is less, then the results are acceptable and no correction need be applied to the total volume of dry gas metered. If a higher leakage rate is obtained, then the tester shall either record the leakage rate and plan to correct the sample volume, as shown in subdivision (f)(iii) of this rule, or shall void the sampling run.

Immediately after component changes, leak checks may be performed. If leak checks are done, then the procedure outlined in paragraph (i)(D)(1) of this subdivision shall be used.

(3) Post-test leak check. A leak check is required at the conclusion of each sampling run. The leak check shall be performed in accordance with the procedures in paragraph (i)(D)(1) of this subdivision, except that it shall be conducted at a vacuum equal to or greater than the maximum value reached during the sampling run. If the leakage rate is not more than 0.00057 m<sup>3</sup>/min (0.02 cfm) or 4% of the average sampling rate, whichever is less, then the results are acceptable and no correction need be applied to the total volume of dry gas metered. If a higher leakage rate is obtained, then the tester shall either record the leakage rate and correct the sample volume, as shown in subdivision (f)(iii) of this rule, or shall void the sampling run.

(E) Particulate train operation. During the sampling run, maintain an isokinetic sampling rate that is within 10% of true isokinetic, unless otherwise specified by the department.

For each run, record the data required on a data sheet such as the data sheet in figure 104. Record the initial dry-gas meter reading. Record the dry-gas meter readings at the beginning and end of each sampling time increment, when changes in flow rates are made, before and after each leak check, and when sampling is halted. Take other readings required by figure 104 at least once at each sample point during each time increment, and take additional readings when significant changes (20% variation in velocity head readings) necessitate additional adjustments in flow rate. Level and zero the manometer. Because the manometer level and zero may drift due to vibrations and temperature changes, make periodic checks during the traverse. Clean the portholes before the test run to minimize the chance of sampling deposited material. To begin sampling, remove the nozzle cap and verify that the pitot tube and probe are properly positioned. Position the nozzle at the first traverse point with the tip pointing directly into the gas stream. Immediately start the pump and adjust the flow to isokinetic conditions.

Nomographs that aid in the rapid adjustment of the isokinetic sampling rate without excessive computations are available. These nomographs are designed for use when the type S pitot tube coefficient is  $0.85 \pm 0.02$  and the stack gas equivalent density (dry molecular weight) is equal to  $29 \pm 4$ . APTD-0576 details the procedure for using the nomographs. If  $C_p$  and  $M_d$  are outside the above stated ranges, do not use the nomographs unless appropriate steps (subdivision (g)(iv) of this rule) are taken to compensate for the deviations.

When the stack is under significant negative pressure (height of impinger stem), take care to pull low flow when inserting the probe into the stack to prevent water from backing into the sample tubing and to avoid pulsation through the filter and possible loss of materials.

When the probe is in position, block off the openings around the probe and porthole to prevent unrepresentative dilution of the gas stream.

Traverse the stack cross section, as required by method 1 or as specified by the department, being careful not to bump the probe nozzle into the stack walls when sampling near the walls or when removing or inserting the probe through the portholes; this minimizes the chance of extracting deposited material.

During the test run, add more ice and, if necessary, salt to maintain a temperature of less than 20 degrees Centigrade (68 degrees Fahrenheit) at the condenser/silica gel outlet. Also, periodically check the level and zero of the manometer.

If the pressure drop across the filter becomes too high and makes isokinetic sampling difficult to

maintain, the filter may be replaced in the midst of a sample run. It is recommended that another complete filter assembly be used rather than attempting to change the filter itself. Before a new filter assembly is installed, conduct a leak check (paragraph (i)(D)(2) of this subdivision). The total particulate weight shall include the summation of all filter assembly catches.

A single train shall be used for the entire sample run, except in cases where simultaneous sampling is required in 2 or more separate ducts, at 2 or more different locations within the same duct, or where equipment failure necessitates a change of trains. In all other situations, the use of 2 or more trains shall be subject to the approval of the department.

When 2 or more trains are used, separate analyses of the front-half and, if applicable, impinger catches from each train shall be performed, unless identical nozzle sizes were used on all trains. If identical nozzle sizes were used, the front-half catches from the individual trains may be combined, as may the impinger catches, and 1 analysis of front-half catch and 1 analysis of impinger catch may be performed. Consult with the department for details concerning the calculation of results when 2 or more trains are used.

At the end of the sample run, turn off the coarse adjust valve, remove the probe and nozzle from the stack, turn off the pump, record the final dry-gas meter reading, and conduct a post-test leak check, as outlined in paragraph (i)(D)(3) of this subdivision. Leak-check the pitot lines as described in method 2, section 3.1; the lines shall pass this leak check to validate the velocity head data.

(F) Calculation of percent isokinetic. Calculate percent isokinetic (see subdivision (f) of this rule) to determine if the run was valid or if another test run should be made. If there was difficulty in maintaining isokinetic rates due to source conditions, consult with the department for possible variance on the isokinetic rates.

(ii) Sample recovery. Proper cleanup procedure begins as soon as the probe is removed from the stack at the end of the sampling period. Allow the probe to cool.

When the probe can be safely handled, wipe off all external particulate matter near the tip of the probe nozzle and place a cap over it to prevent losing or gaining particulate matter. Do not cap off the probe tip tightly while the sampling train is cooling down as this creates a vacuum in the filter holder and draws water from the impingers into the sample tube.

Before moving the sampling train to the cleanup site, make sure all condensed water in the probe and flexible sample lines are drained into the first impinger. Disconnect all sample lines and remove the nozzle-filter set assembly from the probe. Cap all openings to prevent contamination or accidental loss of sample. Remove all excess particulate from the exterior of the nozzle-filter assembly to prevent contamination during disassembly.

Transfer the nozzle-filter set assembly and impinger set to the cleanup area. The cleanup area shall be clean and protected from the wind so that the chances of contaminating or losing the sample are minimized.

Save a portion of the solvent used for cleanup as a blank. Take 200 ml of this solvent directly from the wash bottle being used and place it in a glass sample container labeled "solvent blank".

Inspect the train before and during disassembly and note any abnormal conditions. Treat the samples in the following manner:

Container Nos. 1, 1A. Carefully remove the filters from the filter holders and place in their identified containers. Use a pair of tweezers or clean disposable surgical gloves, or both, to handle the filters. Carefully transfer to the container any particulate matter or filter fibers, or both, that adhere to the filter holder gasket by using a dry nylon bristle brush or sharp-edged blade, or both. Seal the containers.

Container No. 2. Taking care to see that particulate on the outside of the nozzle and filter holders does not get into the sample, the testor shall carefully remove the nozzle and clean the inside surface by rinsing with solvent from a wash bottle and brushing with a nylon bristle brush. Brush until the solvent rinse shows no visible particles and then make a final rinse of the inside surface with solvent.

After ensuring that all joints have been cleaned of all extraneous material, the testor shall



quantitatively remove particulate from the filter holders by rubbing the surfaces with a nylon bristle brush and rinsing with solvent. Rinse each surface 3 times, or more if needed, to remove visible particulate. Make a final rinse of the brush and filter holder set. After all solvent washings and particulate matter have been collected in the sample container, tighten the lid on the sample container so that solvent will not leak out when it is shipped to the laboratory. Mark the height of the fluid level to determine if leakage occurred during transport. Label the container to clearly identify its contents.

Container No. 3. Note the color of the indicating silica gel to determine if it has been completely spent and make a notation of its condition. Transfer the silica gel from the third impinger to its original container and seal. A funnel may make it easier to pour the silica gel without spilling it. A rubber policeman may be used as an aid in removing the silica gel from the impinger. It is not necessary to remove the small amount of dust particles that adhere to the impinger wall and are difficult to remove. Since the gain in weight will be used for moisture calculations, do not use any water or other liquids to transfer the silica gel. If a balance is available in the field, follow the procedure for container No. 3 in paragraph (iii) of this subdivision.

Impinger water. Treat the impingers in the following manner: Make a notation of any color or film in the liquid catch. Measure the liquid that is in the first 2 impingers to within  $\pm 1$  ml by using a graduated cylinder or by weighing it to within  $\pm 1.0$  g by using a balance if one is available. Record the volume or weight of liquid present. This information is required to calculate the moisture content of the effluent gas.

Discard the liquid after measuring and recording the volume or weight, unless analysis of the impinger catch is required (subdivision (b)(i)(G) of this rule).

If a different type of condenser is used, measure the amount of moisture condensed either volumetrically or gravimetrically. If possible, containers shall be shipped in a manner that keeps them upright at all times.

(iii) Analysis. Record the data required on a sheet such as the sheet in figure 106. Handle each sample container in the following manner:

Container Nos. 1, 1A. Analyze and report each filter separately. Transfer the filter and any loose particulate from the sample container to a tared-glass weighing dish. Dry the filter in an oven at 105 degrees Centigrade (220 degrees Fahrenheit) for a minimum of 2 hours, cool for at least 1 hour in a desiccator containing anhydrous calcium sulfate and weigh and record its weight to the nearest 0.1 mg. During the weighing the filter shall not be exposed to the laboratory atmosphere for a period greater than 2 minutes or a relative humidity above 50%. Procedures, other than those specified, that account for relative humidity effects may be used, subject to the approval of the department. The method used for drying and weighing of filters shall be consistent before and after the test.

Container No. 2. Note the level of liquid in the container and confirm on the analysis sheet if leakage occurred during transport. If a noticeable amount of leakage has occurred, then either void the sample or use methods, subject to the approval of the department, to correct the final results. Measure the liquid in this container either volumetrically to  $\pm 1$  ml or gravimetrically to  $\pm 1.0$  g. Transfer the contents to a tared 250 ml beaker and evaporate to dryness either at ambient temperature and pressure for acetone or at 95 degrees Centigrade (203 degrees Fahrenheit) in an oven for distilled water.

Then subject the sample to 250 degrees Centigrade (482 degrees Fahrenheit) in an oven for 2 to 3 hours. Desiccate 24 hours and weigh to a constant weight. Report the results to the nearest 0.1 mg.

Container No. 3. Weigh the spent silica gel, or silica gel plus impinger, to the nearest 0.5 g using a balance. This step may be conducted in the field.

"Solvent blank" container. Measure solvent in this container either volumetrically or gravimetrically. Transfer the contents to a tared 250 ml beaker and evaporate to dryness either at ambient temperature and pressure for acetone or at 95 degrees Centigrade (203 degrees Fahrenheit) in an oven for distilled water. Then subject the sample to 250 degrees Centigrade (482 degrees Fahrenheit) in an oven for 2 to 3 hours. Desiccate for 24 hours and weigh to a constant weight. Report the results to the

nearest 0.1 mg.

If acetone is used, the contents of Container No. 2, as well as the acetone blank container, may be evaporated at temperatures higher than ambient. If evaporation is done at an elevated temperature, then the temperature shall be closely supervised, and the contents of the beaker shall be swirled occasionally to maintain an even temperature. Use extreme care, as acetone is highly flammable and has a low flash point.

(e) Calibration. Maintain a laboratory log of all calibrations. Calibrations shall comply with the following provisions:

(i) Probe nozzle. Probe nozzles shall be calibrated before their initial use in the field. Using a micrometer, measure the inside diameter of the nozzle to the nearest 0.025 mm (0.001 in.). Make 3 separate measurements using different diameters each time and obtain the average of the measurements. The difference between the high and low numbers shall not exceed 0.1 mm (0.004 in.). When nozzles become nicked, dented, or corroded, they shall be reshaped, sharpened, and recalibrated before use. Each nozzle shall be permanently and uniquely identified.

(ii) Pitot tube. The type S pitot tube assembly shall be calibrated according to the procedures in section 4 of method 2.

(iii) Metering system. Before its initial use in the field, the metering system shall be calibrated according to the procedure in APTD-0576. Instead of physically adjusting the dry-gas meter dial readings to correspond to the wet-test meter readings, calibration factors may be used to mathematically correct the gas meter dial readings to the proper values. Before calibrating the metering system, a leak check may be conducted. For metering systems having diaphragm or rotary pumps, the normal leak check procedure will not detect leakages within the pump. For these cases, the following leak check procedure may be used: Make a 10-minute calibration run at 0.00057 m<sup>3</sup>/min (0.02 cfm); at the end of the run, take the difference of the measured wet-test meter and dry-gas meter volumes; divide the difference by 10 to get the leak rate. The leak rate shall not exceed 0.00057 m<sup>3</sup>/min (0.02 cfm).

After each field use, the calibration of the metering system shall be checked by performing 3 calibration runs at a single, intermediate orifice setting, based on the previous field test, with the vacuum set at the maximum value reached during the test series. To adjust the vacuum, insert a valve between the wet-test meter and the inlet of the metering system. Calculate the average value of the calibration factor. If the calibration has changed by more than 5%, then recalibrate the meter over the full range of orifice settings, as outlined in APTD-0576.

Alternatively, a spirometer may be substituted for a wet-test meter in the above calibration procedures.

Alternative procedures, such as using the orifice meter coefficients, may be used, subject to the approval of the department. If the dry-gas meter coefficient values obtained before and after a test series differ by more than 5%, then the test series shall be performed using whichever meter coefficient value (before or after) gives the lower value of total sample volume.

(iv) Temperature gauges. Use the procedure in section 4.3 of method 2 to calibrate in-stack temperature gauges. Dial thermometers, such as those used for the dry-gas meter and condenser outlet, shall be calibrated against mercury-in-glass thermometers.

(v) Leak check of metering system shown in figure 102. That portion of the sampling train from the pump to the orifice meter shall be leak-checked before initial use and after each shipment. Leakage after the pump will result in less volume being recorded than is actually sampled. The following procedure is suggested (see figure 107): Close the main valve on the meter box. Insert a 1-hole rubber stopper with rubber tubing attached into the orifice exhaust pipe. Disconnect and vent the low side of the orifice manometer. Close off the low side orifice tap. Pressurize the system to 13 to 18 cm (5 to 7 in.) water column by blowing into the rubber tubing. Pinch off the tubing and observe the manometer for 1 minute. A loss of pressure on the manometer indicates a leak in the meter box; leaks, if present, shall be corrected.

(vi) Barometer. Calibrate against a mercury barometer.

(f) Calculations. When carrying out calculations, retain at least 1 extra decimal figure beyond that of the acquired data. Round off figures after the final calculation. Other forms of the equations may be used if they give equivalent results. The following provisions apply to calculations:

(i) Nomenclature:

$A_n$  = Cross-sectional area of nozzle,  $m^2(ft.^2)$ .

$A$  = Cross-sectional area of stack or flue at the point of sampling,  $ft^2$ .

$B_{ws}$  = Water vapor in the gas stream, proportion by volume, expressed as a fraction.

$B_{wi}$  = Percent water vapor in gas entering source particulate control device determined by method 4.

$B_{wo}$  = Percent water vapor in gas exiting source particulate control device.

$C_a$  = Wash blank residue concentration,  $mg/g$ .

$C_s$  = Concentration of particulate matter in stack gas, pounds per 1,000 pounds of actual stack gas.

$C_{sD}$  = Concentration of particulate matter in stack gas, moisture excluded, pounds per 1000 pounds of dry stack gas.

$C_{s50}$  = Concentration of particulate matter corrected to 50% excess air, pounds per 1000 pounds of stack gas.

$C_{s50D}$  = Concentration of particulate matter corrected to 50% excess air, excluding any water addition from a collector, pounds per 1000 pounds of stack gas.

$E$  = Mass emission rate of particulate,  $lb/hr$ .

$F_{50}$  = Concentration conversion factor to 50% excess air with no moisture alterations in exhaust.

$F_{50D}$  = Concentration conversion factor to 50% excess air, excluding any moisture added to exhaust gas by pollution collection system.

$F_D$  = Concentration conversion factor to dry basis, excluding any water in the stack gas.

$I$  = Percent of isokinetic sampling.

$L_a$  = Maximum acceptable leakage rate for either a pretest leak check or for a leak check following a component change; equal to  $0.00057 m^3/min$  ( $0.02 cfm$ ) or 4% of the average sampling rate, whichever is less.

$L_i$  = Individual leakage rate observed during the leak check conducted before the "ith" component change ( $i = 1, 2, 3 \dots n$ ),  $m^3/min$  ( $cfm$ ).

$L_p$  = Leakage rate observed during the post-test leak check,  $m^3/min$  ( $cfm$ ).

$M_d$  = Molecular weight of dry stack gas,  $g/g$  mole ( $lb/lb$ -mole), calculated by method 3, equation 3-2, using data from integrated method 3.

$m_n$  = Total amount of particulate matter collected,  $mg$ .

$M_w$  = Molecular weight of water,  $18.0 g/g$ -mole ( $18.0 lb/lb$ -mole).

$m_a$  = Mass of residue of solvent after evaporation,  $mg$ .

$m_g$  = Total weight of gas samples through nozzle,  $lb$ .

$P_{bar}$  = Barometric pressure at the sampling site,  $mm Hg$  ( $in. Hg$ ).

$P_s$  = Absolute stack gas pressure.

$P_{std}$  = Standard absolute pressure, 760 mm Hg (29.92 in. Hg).  
 $R$  = Ideal gas constant, 0.06236 mm Hg-m<sup>3</sup>/°K-g-mole (21.85 in. Hg-ft.<sup>3</sup>/°R-lb-mole).  
 $T_m$  = Absolute average dry-gas meter temperature (see figure 104), °K (°R).  
 $T_s$  = Absolute average stack gas temperature (see figure 104), °K (°R).  
 $T_{std}$  = Standard absolute temperature, 294.1°K (530°R).  
 $V_a$  = Volume of solvent blank, ml.  
 $V_{aw}$  = Volume of solvent used in wash, ml.  
 $V_{lc}$  = Total volume of liquid collected in impingers and silica gel (see figure 106), ml.  
 $V_m$  = Volume of gas sample as measured by the dry-gas meter, dcm (dcf).  
 $V_{m(std)}$  = Volume of gas sample measured by the dry-gas meter, corrected to standard conditions, dscm (dscf).  
 $V_{w(std)}$  = Volume of water vapor in the gas sample, corrected to standard conditions, scm (scf).  
 $V_s$  = Stack gas velocity, calculated by method 2, equation 2-9, using data obtained from method 5, m/sec (ft./sec).  
 $W_a$  = Weight of residue in solvent wash, mg.  
 $Y$  = Dry-gas meter calibration factor.  
 $\Delta H$  = Average pressure differential across the orifice meter (see figure 104), mm H<sub>2</sub>O (in. H<sub>2</sub>O).  
%O<sub>2</sub> = Percent oxygen in stack gas by volume (dry basis).  
%N<sub>2</sub> = Percent nitrogen in stack gas by volume (dry basis).  
 $\rho_a$  = Density of solvent, mg/ml.  
 $\rho_{s(std)}$  = Density of all sampled gas at standard conditions, lb/ft.<sup>3</sup>  
 $\rho_w$  = Density of water, 0.9982 g/ml (0.002201 lb/ml).  
 $\theta$  = Total sample time, min.  
 $\theta_1$  = Sample time, interval, from the beginning of a run until the first component change, min.  
 $\theta_i$  = Sampling time interval, between 2 successive component changes, beginning with the interval between the first and second changes, min.  
 $\theta_p$  = Sampling time interval, from the final (nth) component change until the end of the sampling run, min.  
13.6 = Specific gravity of mercury.  
60 = Sec/min.  
100 = Conversion to percent.  
386.9 = Cubic feet per lb-mole of ideal gas at standard conditions.  
453.6 = Conversion of pounds to grams.  
3600 = Conversion of hours to sec.  
1000 = Conversion of 1000 lb units to lb units.

(ii) Average the dry-gas meter temperature and average the orifice pressure drop. See data sheet

(figure 5-2).

(iii) Dry gas volume. Correct the sample volume measured by the dry-gas meter to standard conditions (21.11 degrees Centigrade, 760 mm Hg or 70 degrees Fahrenheit, 29.92 in. Hg) by using equation 5-1.

equation 5-1

$$V_{m(std)} = \frac{V_m Y T_{std} (P_{bar} + \Delta H/13.6)}{T_m P_{std}} = K_1 V_m Y \frac{(P_{bar} + \Delta H/13.6)}{T_m}$$

Where:

$K_1 = 0.3869$  °K/mm Hg for metric units.  
 $= 17.71$  °R/in. Hg for English units.

Equation 5-1 may be used as written. However, if the leakage rate observed during any of the mandatory leak checks (for example, the post-test leak check or leak checks conducted before component changes) exceeds  $L_a$ , equation 5-1 shall be modified in the following manner:

(A) Case I. No component changes made during sampling run. In this case, replace  $V_m$  in equation 5-1 with the following expression:

$$V_m - (L_p - L_a)\theta$$

(B) Case II. One or more component changes made during the sampling run. In this case, replace  $V_m$  in equation 5-1 by the following expression:

$$V_m - (L_1 - L_a)\theta_1 - \sum_{i=2}^n (L_i - L_a)\theta_i - (L_p - L_a)\theta_p$$

and substitute only for those leakage rates ( $L_i$  or  $L_p$ ) that exceed  $L_a$ .

(iv) Volume of water vapor.

equation 5-2

$$V_{w(std)} = V_{1c} (P_w/M_w) (R T_{std}/P_{std}) = K_2 V_{1c}$$

Where:

$K_2 = 0.001338$  mm/ml for metric units.

(v) Moisture content.

equation 5-3

$$B_{ws} = V_{w(std)} / (V_{m(std)} + V_{w(std)})$$

In saturated or water droplet--laden gas streams, 2 calculations of the moisture content of the stack gas shall be made: 1 from the impinger analysis (equation 5-3), and a second from the assumption of saturated conditions. The lower of the 2 values of  $B_{ws}$  shall be considered correct. The procedure for determining the moisture content based upon assumption of saturated conditions is given in the note of section 1.2 of method 4. For the purpose of this method, the average stack gas temperature from figure 104 may be used to make the determination, if the accuracy of the instack temperature sensor is  $\pm 1$  degree Centigrade (2 degrees Fahrenheit).

(vi) Solvent blank concentration.

equation 5-4

$$C_a = m_a / (V_a P_a)$$

(vii) Solvent wash blank.

equation 5-5

$$W_a = C_a V_{aw} P_a$$

(viii) Total particulate weight. Determine the total particulate catch from the sum of the weights obtained from containers 1, 1A, and 2 less the wash solvent blank (see figure 106).

Refer to subdivision (d)(i)(E) of this rule to assist in the calculation of results involving 2 or more pairs of filters or 2 or more sampling trains.

(ix) Sampled gas density. Determine the density of the gas sampled from the stack, at standard conditions (lb/ft.<sup>3</sup>).

equation 5-6

$$P_{s(std)} = (M_d (1 - B_{ws}) + M_w B_{ws}) / 386.9$$

(x) Total weight of gas sampled (lbs).

equation 5-7

$$m_g = (V_{m(std)} + V_{w(std)}) P_{s(std)}$$

(xi) Particulate concentration (lbs/1000 lbs).

equation 5-8

$$C_s = m_n / (453.6 m_g)$$

(xii) Excess air and moisture correction factors:

(A) Correction factor to 50% excess air for those sources with or without any particulate collector where no increase in moisture content of the exhaust gas occurs after the process and before the point of sampling.

equation 5-9

$$F_{50} = \frac{M_d + 18 B_{wo} / (100 - B_{wo})}{0.1826 \%N_2 - 2.0592 \%O_2 + M_d + 18 B_{wo} / (100 - B_{wo})}$$

(B) Correction factor to 50% excess air for those sources with a wet collection device (scrubber) that increases the moisture content of the exhaust gas after the process and before the point of sampling.

equation 5-10

$$F_{50D} = \frac{M_d + 18 B_{wo} / (100 - B_{wo})}{0.1826 \%N_2 - 2.0592 \%O_2 + M_d + 18 B_{wi} / (100 - B_{wi})}$$

(C) Correction factor to convert the actual concentration,  $C_s$ , to dry conditions.

equation 5-11

$$F_D = \frac{M_d + 18 B_{wo} / (100 - B_{wo})}{M_d}$$

(xiii) Converted particulate concentrations, where applicable under the department's rules or permit.

equation 5-12

$$C_{s50} = C_s F_{50}$$

equation 5-13

$$C_{s50D} = C_s F_{50D}$$

equation 5-14

$$C_{s0} = C_s F_D$$

(xiv) Mass emission rate (lb/hr).

equation 5-15

$$E = \frac{3600 A V_s C_s P_s T_{std} P_{s(std)}}{1000 T_s P_{std}} = K_3 A V_s C_s P_s P_{s(std)} / T_s$$

Where:

$K_3 = 63.77$  for English units.

(xv) Isokinetic variation:

(A) Calculation from raw data.

equation 5-16

$$I = \frac{100 T_s (K_4 V_{lc} + (V_m / T_m)(P_{bar} + \Delta H / 13.6))}{60 \theta V_s P_s A_n}$$

Where:

$K_4 = 0.003458$  mm Hg -  $m^3/ml$  -  $^{\circ}K$  for metric units.

$= 0.002672$  in. Hg -  $ft.^3/ml$  -  $^{\circ}R$  for English units.

(B) Calculation from intermediate values.

equation 5-17

$$I = \frac{T_s V_{m(std)} P_{std} 100}{T_{std} V_s \theta A_n P_s 60 (1 - B_{ws})} = K_5 \frac{T_s V_{m(std)}}{P_s V_s A_n \theta (1 - B_{ws})}$$

Where:

$K_5 = 4.307$  for metric units.

$= 0.09409$  for English units.

(xvi) Acceptable results. If  $90\% \leq I \leq 110\%$ , then the results are acceptable. If the results are low in comparison to the standard and  $I$  is beyond the acceptable range, or if  $I$  is less than 90%, then the department may opt to accept the results. Otherwise, reject the results and repeat the test.

(g) Bibliography:

(i) Federal Register, Volume 42, No. 160, Part 160, Chapter 1, Title 40, Appendix A, Method 5, August 18, 1977.

(ii) Martin, Robert M. Construction Details of Isokinetic Source Sampling Equipment. Environmental Protection Agency. Research Triangle Park, N.C. APTD-0581. April, 1971.

(iii) Rom, Jerome J. Maintenance, Calibration, and Operation of Isokinetic Source Sampling Equipment. Environmental Protection Agency. Research Triangle Park, N.C. APTD-0576. March, 1972.

(iv) Shigehara, R. T. "Adjustments in the EPA Nomograph for Different Pitot Tube Coefficients and Dry Molecular Weights." Stack Sampling News, 2:4 - 11. October, 1974.

(v) Guidelines for Source Testing of Particulate. Michigan Department of Natural Resources, Air Quality Division. June 1, 1977.

History: 1985 MR 2, Eff. Feb. 22, 1985; 1992 MR 9, Eff. Oct. 31, 1992; 2002 MR 5, Eff. Mar. 19, 2002; Corrected 2004 MR 18, Oct. 15, 2004; 2005 MR 8, Eff. Apr. 29, 2005.

**R 336.2012 Reference test method 5C.**

Rule 1012. Reference test method 5C, outstack filtration method, reads as follows:

(a) The principle, applicability, and performance test criteria are as follows:

(i) Principle. Particulate matter is withdrawn isokinetically from the source and collected on solid filtering media maintained at a temperature in the range of  $120 \pm 14$  degrees Centigrade ( $248 \pm 25$  degrees Fahrenheit) or such other temperature as specified by the department's rules or a permit condition, or as approved by the department for a particular application. The particulate mass, which includes any material that condenses at or above the filtration temperature, is determined gravimetrically after removal of uncombined water.

(ii) Applicability. This method is applicable for the determination of particulate emissions from stationary sources as identified in table 31 of R 336.1331. The method is also applicable when specifically provided for in the department's rules, orders, a permit to install, or a permit to operate.

(iii) Performance test criteria:

(A) A performance test shall consist of a minimum of 3 separate samples of a specific air contaminant conducted within a 36- hour period, unless otherwise authorized by the department. Each of the 3 separate samples shall be obtained while the source is operating at a similar production level. For the purpose of determining compliance with an applicable emission limit, rule, or permit condition, the arithmetic mean of results of the 3 samples shall apply. If a sample is accidentally lost or conditions occur in which 1 of the 3 samples must be discontinued because of forced shutdown, failure of an irreplaceable portion of the sampling train, extreme meteorological conditions, or other circumstances beyond the owner's or operator's control, compliance may, upon the approval of the department, be determined using the arithmetic mean of the results of 2 samples.

(B) For any source that is subject to an emission limitation calculated to 50% excess air, the multipoint, integrated sampling procedure of R 336.2004(1)(c) shall be used for gas analysis. For all other sources that require a determination of the molecular weight of the exhaust, any optional sampling procedure of R 336.2004(1)(c) may be used. Alternatives or modifications to procedures are subject to the approval of the department.

(C) The minimum volume per sample shall be 30 cubic feet of dry gas corrected to standard conditions (70 degrees Fahrenheit, 29.92 inches mercury). Minimum sample time shall be 60 minutes, which may be continuous or a combination of shorter sampling periods for sources that operate in a cyclic manner. Smaller sampling times or sample volumes, when necessitated by process variables or other factors, may be approved by the department.

(D) For any source whose emission control device alters the moisture content of the exhaust gas, a moisture determination shall be performed in a location upstream from the emission control device and in accordance with R 336.2004(1)(d) or an alternative method approved by the department.

(b) The following provisions apply to apparatus:

(i) Sampling train. A schematic of the sampling train used in this method is shown in figure 103. Construction details for many, but not all, of the train components are given in APTD-0581 (subdivision (g)(ii) of this rule). For changes from the APTD-0581 document and for allowable modifications to figure 103, consult with the department.

The operating and maintenance procedures for many, but not all, of the sampling train are described in APTD-0576 (subdivision (g)(iii) of this rule). Since correct usage is important in obtaining valid results, all users shall read APTD-0576 and adopt the applicable operating and maintenance procedures outlined in it, unless otherwise specified herein. The sampling train consists of the following components:



(A) Probe nozzle. Stainless steel (316) or glass with sharp, tapered leading edge. The angle of taper shall be less than 30 degrees and the taper shall be on the outside to preserve a constant internal diameter. The probe nozzle shall be of the button-hook design, unless otherwise specified by the department. If made of stainless steel, the nozzle shall be constructed from seamless tubing. Other materials of construction may be used, subject to the approval of the department.

A range of nozzle sizes suitable for isokinetic sampling shall be available, for example, 0.32 to 1.27 cm (1/8 to 1/2 in.) - or larger if higher volume sampling trains are used - inside diameter (ID) nozzles in increments of 0.16 cm (1/16 in.). Each nozzle shall be calibrated according to the procedures outlined in subdivision (e) of this rule.

(B) Probe liner. Borosilicate or quartz glass tubing with a heating system capable of maintaining a gas temperature at the exit end during sampling of  $120 \pm 14$  degrees Centigrade ( $248 \pm 25$  degrees Fahrenheit), another temperature as specified by the department's rules, or a temperature approved by the department for a particular application. The tester may opt to operate the equipment at a temperature lower than that specified. Since the actual temperature at the outlet of the probe is not usually monitored during sampling, probes constructed according to APTD-0581 which utilize the calibration curves of APTD-0576, or calibrated according to the procedure outlined in APTD-0576, are acceptable.

Either borosilicate or quartz glass probe liners may be used for stack temperatures up to about 480 degrees Centigrade (900 degrees Fahrenheit); quartz liners shall be used for temperatures between 480 and 900 degrees Centigrade (900 and 1,650 degrees Fahrenheit). Both types of liners may be used at higher temperatures than specified for short periods of time, subject to the approval of the department. The softening temperature for borosilicate is 820 degrees Centigrade (1,508 degrees Fahrenheit) and for quartz it is 1,500 degrees Centigrade (2,732 degrees Fahrenheit).

When practical, every effort shall be made to use borosilicate or quartz glass probe liners. Alternatively, metal liners, such as 316 stainless steel, Incoloy 825, or other corrosion-resistant materials made of seamless tubing, may be used, subject to the approval of the department.

(C) Pitot tube. Type S, as described in section 2.1 of method 2, or other device approved by the department. The pitot tube shall be attached to the probe, as shown in figure 103, to allow constant monitoring of the stack gas velocity. The impact (high pressure) opening plane of the pitot tube shall be even with or above the nozzle entry plane (see method 2, figure 2-6b) during sampling. The type S pitot tube assembly shall have a known coefficient, determined as outlined in section 4 of method 2.

(D) Differential pressure gauge. Incline manometer or equivalent devices (2), as described in section 2.2 of method 2. One manometer shall be used for velocity head (p) readings, and the other shall be used for orifice differential pressure readings.

(E) Filter holders. Two separate filter holders in series or 1 filter holder with separate filter supports and seals for 2 filters. One filter holder with 2 filters held in contact with each other is not acceptable. Materials of construction may be stainless steel (316), glass, teflon, or such other material approved by the department.

(F) Filter heating system. Any heating system capable of maintaining a temperature around the filter holder during sampling of  $120 \pm 14$  degrees Centigrade ( $248 \pm 25$  degrees Fahrenheit), another temperature as specified by the department's rules or a permit condition, or a temperature approved by the department for a particular application. Alternatively, the tester may opt to operate the equipment at a temperature lower than that specified. A temperature gauge capable of measuring temperature to within 3 degrees Centigrade (5.4 degrees Fahrenheit) shall be installed so that the temperature around the filter holders can be regulated and monitored during sampling. Heating systems other than the one shown in APTD-0581 may be used.

(G) Condenser. The following system shall be used to determine the stack gas moisture content: Three impingers connected in series with leak-free ground glass fittings or any similar leak-free noncontaminating fittings. All impingers shall be of the Greenburg-Smith design and shall be modified by replacing the tip with a 1.3 cm (1/2 in.) ID glass tube extending to about 1.3 cm (1/2 in.) from the

bottom of the flask. Modifications, such as using flexible connections between the impingers or using materials other than glass, are permitted subject to the approval of the department's staff. The first impinger shall contain a known quantity of water (subdivision (d)(i)(C) of this rule), the second shall be empty, and the third shall contain a known weight of silica gel or equivalent desiccant.

Alternatively, any system that cools the sample gas stream and allows measurement of the water condensed and moisture leaving the condenser, each to within 1 ml or 1 g, may be used subject to the approval of the department. In any case, the means for measuring the moisture leaving the condenser shall be by passing the sample gas stream through a tared silica gel, or equivalent desiccant, trap with exit gases kept below 20 degrees Centigrade (68 degrees Fahrenheit) and determining the weight gain.

If a determination of the particulate matter collected in the impingers is required by the department's rules, a permit to install, or a permit to operate, the impinger system described in this subparagraph shall be used, without modification. Contact the department as to the sample recovery and analysis of the impinger contents.

(H) Metering system. Vacuum gauge, leak-free pump, thermometers capable of measuring temperature to within 3 degrees Centigrade (5.4 degrees Fahrenheit), dry-gas meter capable of measuring volume to within 2%, and related equipment as shown in figure 103. Other metering systems capable of maintaining sampling rates within 10% of isokinetic and capable of determining sample volumes to within 2% may be used, subject to the approval of the department. When the metering system is used in conjunction with a pitot tube, the system shall enable checks of isokinetic rates.

Sampling trains utilizing metering systems designed for higher flow rates than those described in APTD-0581 or APTD-0576 may be used if the specifications of this method are met.

(I) Barometer. Mercury, aneroid, or other barometer capable of measuring atmospheric pressure to within 2.5 mm Hg (0.1 in. Hg). In many cases, the barometric reading may be obtained from a nearby national weather service station. When obtained from this source, the station value, which is the absolute barometric pressure, shall be requested and an adjustment for elevation differences between the weather station and sampling point shall be applied at a rate of minus 2.5 mm Hg (0.1 in. Hg) per 30 m (100 ft.) elevation increase or vice versa for elevation decrease.

(J) Gas density determination equipment. Temperature sensor and pressure gauge, as described in sections 2.3 and 2.4 of method 2, and gas analyzer, if necessary, as described in method 3. The temperature sensor shall, preferably, be permanently attached to the pitot tube or sampling probe in a fixed configuration such that the tip of the sensor extends beyond the leading edge of the probe sheath and does not touch any metal. Alternatively, the sensor may be attached just prior to use in the field. Note, however, that if the temperature sensor is attached in the field, the sensor shall be placed in an interference-free arrangement with respect to the type S pitot tube openings (see method 2, figure 2.7). As a second alternative, if a difference of not more than 1% in the average velocity measurement is to be introduced, the temperature gauge need not be attached to the probe or pitot tube. This alternative is subject to the approval of the department.

(ii) Sample recovery. The following items are needed:

(A) Probe-liner and probe-nozzle brushes. Nylon bristle brushes with stainless steel wire handles. The probe brush shall have extensions, at least as long as the probe, made of stainless steel, nylon, teflon, or similarly inert material. The brushes shall be properly sized and shaped to brush out the probe liner and nozzle.

(B) Wash bottles--2. Glass wash bottles are recommended; polyethylene wash bottles may be used at the option of the tester. It is recommended that acetone not be stored in polyethylene bottles for longer than a month.

(C) Glass sample storage containers. Chemically resistant, borosilicate glass bottles, for acetone washes, 500 ml or 1000 ml. Screw cap liners shall either be rubber-backed teflon or shall be constructed so as to be leak-free and resistant to chemical attack by acetone. Narrow-mouth glass bottles have been found to be less prone to leakage. Alternatively, polyethylene bottles may be used.

(D) Filter containers. Glass, polyethylene, or aluminum tube containers, unless otherwise specified by the department.

(E) Graduated cylinder or balance. To measure condensed water to within 1 ml or 1 g. Graduated cylinders shall have subdivisions of not more than 2 ml. Most laboratory balances are capable of weighing to the nearest 0.5 g or less. Any of these balances are suitable for use here and in paragraph (iii)(D) of this subdivision.

(F) Plastic storage containers. Airtight containers to store silica gel.

(G) Funnel and rubber policeman. To aid in the transfer of silica gel to container; not necessary if silica gel is weighed in the field.

(H) Funnel. Glass or polyethylene, to aid in sample recovery.

(iii) Analysis. The following equipment is needed for analysis:

(A) Glass weighing dishes.

(B) Desiccator.

(C) Analytical balance. To measure to within 0.1 mg.

(D) Balance. To measure to within 0.5 mg.

(E) Beakers. 250 ml.

(F) Hygrometer. To measure the relative humidity of the laboratory environment.

(G) Temperature gauge. To measure the temperature of the laboratory environment.

(c) The following provisions apply to reagents:

(i) Sampling. The reagents used in sampling are as follows:

(A) Filters. Two outstack filters may be any combination of alundum ceramic thimble filters, type RA-98 or glass fiber filters, type A without organic binder. The size of such filters shall allow proper sampling rates to maintain isokinetics using the nozzle sizes specified in subdivision (b)(i)(A) of this rule.

Alternatively, other types of filters may be used, subject to the approval of the department.

(B) Silica gel. Indicating type, 6 to 16 mesh. If previously used, dry at 175 degrees Centigrade (350 degrees Fahrenheit) for 2 hours. New silica gel may be used as received. Alternatively, other types of desiccants (equivalent or better) may be used, subject to the approval of the department.

(C) Water. When analysis of the material caught in the impingers is required, distilled water shall be used. Run blanks prior to field use to eliminate a high blank on test samples.

(D) Crushed ice.

(E) Stopcock grease. Acetone-insoluble, heat-stable silicone grease. This is not necessary if screw-on connectors with teflon sleeves, or equivalent, are used. Alternatively, other types of stopcock grease may be used, subject to the approval of the department.

(ii) Sample recovery. Washing solvent. Either acetone or distilled water may be used for sample recovery. If acetone is used for washing solvent, then reagent grade, less than 0.001% residue, in glass bottles is required. Acetone from metal containers generally has a high residue blank and shall not be used. Suppliers sometimes transfer acetone to glass bottles from metal containers; thus, acetone blanks shall be run prior to field use and only acetone with low blank values (less than 0.001%) shall be used. A blank value of more than 0.001% of the weight of acetone used shall not be subtracted from the sample weight.

If distilled water is used for washing solvent, use distilled water with less than 0.001% residue. Run blanks before field use to eliminate a high blank on test samples.

(iii) Analysis. Two reagents are required for the analysis:

(A) Solvent. Same as paragraph (ii) of this subdivision for quantitative transfer.

(B) Desiccant. Anhydrous calcium sulfate, indicating type. Alternatively, other types of desiccants may be used, subject to the approval of the department.

(d) The following provisions apply to procedure:

(i) Sampling. The complexity of this method is such that, in order to obtain reliable results, testers

shall be trained and experienced with the test procedures. Sampling shall comply with the following provisions:

(A) Pretest preparation. All the components shall be maintained and calibrated according to the applicable procedures described in APTD-0576, unless otherwise specified in this rule.

Weigh several 200 to 300 g portions of silica gel in airtight containers to the nearest 0.5 g. Record the total weight of the silica gel plus container on each container. As an alternative, the silica gel need not be preweighed, but may be weighed directly in its impinger or sampling holder just prior to train assembly.

Check filters visually against light for irregularities, flaws, pinhole leaks, or cracks. Label filters of the proper size on the back side using numbering machine ink. As an alternative, label the shipping containers (subdivision (b)(ii)(D) of this rule) and keep the filters in these containers at all times, except during sampling and weighing.

Dry the filters in an oven at 105 degrees Centigrade (220 degrees Fahrenheit) for a minimum of 2 hours, cool for at least 1 hour in a desiccator containing anhydrous calcium sulfate, and individually weigh and record their weights to the nearest 0.1 mg. During the weighing, the filters shall not be exposed to the laboratory atmosphere for a period of more than 2 minutes and a relative humidity above 50%. Procedures, other than those specified, that account for relative humidity effects may be used, subject to the approval of the department.

(B) Preliminary determinations. Select the sampling site and the minimum number of sampling points according to method 1 or as specified by the department. Determine the stack pressure, temperature, and the range of velocity heads using method 2; it is recommended that a leak check of the pitot lines (see method 2, section 3.1) be performed. Determine the moisture content using approximation method 4, or its alternatives, for the purpose of making isokinetic sampling rate settings. Determine the stack gas dry molecular weight, as described in method 2, section 3.6; if integrated method 3 sampling is used for molecular weight determination, the integrated bag sample shall be taken simultaneously with, and for the same total length of time as, the particulate sample run.

Select a nozzle size based on the range of velocity heads so that it is not necessary to change the nozzle size in order to maintain isokinetic sampling rates. During the run, do not change the nozzle size. Ensure that the proper differential pressure gauge is chosen for the range of velocity heads encountered (see section 2.2 of method 2).

Select a suitable probe liner and probe length so that all traverse points can be sampled. For large stacks, consider sampling from opposite sides of the stack to reduce the length of probes.

Select a total sampling time greater than or equal to the minimum total sampling time specified in the test procedures for the specific industry so that the sampling time per point is not less than 5 minutes, unless approved by the department, or some greater time interval as specified by the department, and so that the sample volume taken, corrected to standard conditions, exceeds the required minimum total gas sample volume. The latter is based on an approximate average sampling rate.

It is recommended that the number of minutes sampled at each point be an integer or an integer plus 1/2 minute to avoid timekeeping errors.

In some circumstances, such as in batch cycles, it may be necessary to sample for shorter times at the traverse points and to obtain smaller gas sample volumes. In these cases, the department's approval shall first be obtained.

(C) Preparation of collection train. During preparation and assembly of the sampling train, keep all openings where contamination can occur covered until just before assembly or until sampling is about to begin.

Place 100 ml of water in the first impinger, leave the second impinger empty, and transfer approximately 200 to 300 g of preweighed silica gel from its container to the third impinger. More silica gel may be used, but care should be taken to ensure that it is not entrained and carried out from the impinger during sampling. Place the container in a clean place for later use in the sample recovery.

Alternatively, the weight of the silica gel plus impinger may be determined to the nearest 0.5 g and recorded.

Using tweezers or clean disposable surgical gloves, place a labeled (identified) and weighed filter in the filter holder. Be sure that the filter is properly centered and the gasket properly placed so as to prevent the sample gas stream from circumventing the filter. Check the filter for tears after assembly is completed.

When glass liners are used, install the selected nozzle using a Viton A O-ring when stack temperatures are less than 260 degrees Centigrade (500 degrees Fahrenheit) and an asbestos string gasket when temperatures are higher. See APTD-0576 for details. Other connecting systems using either 310 stainless steel or teflon ferrules may be used. When metal liners are used, install the nozzle in the same manner as for glass liners or by a leak-free direct mechanical connection. Mark the probe with heat-resistant tape or by some other method to denote the proper distance into the stack or duct for each sampling point.

Set up the train as in figure 103. If necessary, use a very light coat of silicone grease on all ground glass joints. Grease only the outer portion (see APTD-0576) to avoid the possibility of contamination by the silicone grease.

Place crushed ice around the impingers.

(D) Leak check procedures:

(1) Pretest leak check. A pretest leak check is strongly recommended, but not required, to prevent invalid sampling and wasted time. If the tester opts to conduct the pretest leak check, the following procedure shall be used:

After the sampling train has been assembled, turn it on and set the filter and probe heating systems at the desired operating temperatures. Allow time for the temperatures to stabilize. If a Viton A O-ring or other leak-free connection is used in assembling the probe nozzle to the probe liner, leakcheck the train at the sampling site by plugging the nozzle and pulling a 380 mm Hg (15 in. Hg) vacuum. A lower vacuum may be used, if it is not exceeded during the test.

If an asbestos string is used, do not connect the probe to the train during the leak check. Instead, leak check the train by first plugging the inlet to the filter holder (cyclone, if applicable) and pulling a 380 mm Hg (15 in. Hg) vacuum. A lower vacuum may be used if it is not exceeded during the test. Then connect the probe to the train and leak check at about 25 mm Hg (1 in. Hg) vacuum; alternatively, the probe may be leak checked with the rest of the sampling train, in 1 step, at 380 mm Hg (15 in. Hg) vacuum. Leakage rates in excess of 4% of the average sampling rate or 0.00057 m<sup>3</sup>/min (0.02 cfm), whichever is less, are unacceptable.

The following leak check instructions for the sampling train described in APTD-0576 and APTD-0581 may be helpful. Start the pump with the bypass valve fully open and the coarse adjust valve completely closed. Partially open the coarse adjust valve and slowly close the bypass valve until the desired vacuum is reached. Do not reverse the direction of the bypass valve; this will cause water to back up into the filter holder. If the desired vacuum is exceeded, either leak check at this higher vacuum or end the leak check and start over.

When the leak check is completed, first slowly remove the plug from the inlet to the probe, filter holder, or cyclone (if applicable) and immediately turn off the vacuum pump. This prevents the water in the impingers from being forced backward into the filter holder and prevents silica gel from being entrained backward into the third impinger.

(2) Leak checks during sample run. If, during the sampling run, a component (such as a filter assembly or impinger) change becomes necessary, a leak check shall be conducted immediately before the change is made. The leak check shall be done according to the procedure outlined in paragraph (i)(D)(1) of this subdivision, except that it shall be done at a vacuum equal to or greater than the maximum value recorded up to that point in the test. If the leakage rate is found to be not more than 0.00057 m<sup>3</sup>/min (0.02 cfm) or 4% of the average sampling rate, whichever is less, the results are

acceptable and no correction need be applied to the total volume of dry gas metered; if, however, a higher leakage rate is obtained, the tester shall either record the leakage rate and plan to correct the sample volume, as shown in subdivision (f)(iii) of this rule, or shall void the sampling run.

Immediately after component changes, leak checks are optional; if such leak checks are done, the procedure outlined in paragraph (i)(D)(1) of this subdivision shall be used.

(3) Post-test leak check. A leak check is mandatory at the conclusion of each sampling run. The leak check shall be done in accordance with the procedures outlined in paragraph (i)(D)(1) of this subdivision, except that it shall be conducted at a vacuum equal to or greater than the maximum value reached during the sampling run. If the leakage rate is found to be not more than 0.00057 m<sup>3</sup>/min (0.02 cfm) or 4% of the average sampling rate, whichever is less, the results are acceptable and no correction need be applied to the total volume of dry gas metered. If, however, a higher leakage rate is obtained, the tester shall either record the leakage rate and correct the sample volume, as shown in subdivision (f)(iii) of this rule, or shall void the sampling run.

(E) Particulate train operation. During the sampling run, maintain an isokinetic sampling rate that is within 10% of true isokinetic, unless otherwise specified by the department.

For each run, record the data required on a data sheet such as the one shown in figure 104. Be sure to record the initial dry- gas meter reading. Record the dry-gas meter readings at the beginning and end of each sampling time increment, when changes in flow rates are made, before and after each leak check, and when sampling is halted. Take other readings required by figure 104 at least once at each sample point during each time increment, and take additional readings when significant changes (20% variation in velocity head readings) necessitate additional adjustments in flow rate. Level and zero the manometer. Because the manometer level and zero may drift due to vibrations and temperature changes, make periodic checks during the traverse.

Clean the portholes prior to the test run to minimize the chance of sampling deposited material. To begin sampling, remove the nozzle cap and verify that the pitot tube and probe are properly positioned. Position the nozzle at the first traverse point with the tip pointing directly into the gas stream. Immediately start the pump and adjust the flow to isokinetic conditions. Nomographs that aid in the rapid adjustment of the isokinetic sampling rate without excessive computations are available. These nomographs are designed for use when the type S pitot tube coefficient is  $0.85 \pm 0.02$  and the stack gas equivalent density (dry molecular weight) is equal to  $29 \pm 4$ . APTD-0576 details the procedure for using the nomographs. If  $C_p$  and  $M_d$  are outside the above stated ranges, do not use the nomographs unless appropriate steps (see subdivision (g)(iv) of this rule) are taken to compensate for the deviations.

When the stack is under significant negative pressure (height of impinger stem), take care to pull low flow when inserting the probe into the stack to prevent water from backing into the sample tubing and to avoid pulsation through the filter and possible loss of materials.

When the probe is in position, block off the openings around the probe and porthole to prevent unrepresentative dilution of the gas stream.

Traverse the stack cross section, as required by method 1 or as specified by the department, being careful not to bump the probe nozzle into the stack walls when sampling near the walls or when removing or inserting the probe through the portholes; this minimizes the chance of extracting deposited material.

During the test run, add more ice and, if necessary, salt to maintain a temperature of less than 20 degrees Centigrade (68 degrees Fahrenheit) at the condenser/silica gel outlet. Also, periodically check the level and zero of the manometer.

If the pressure drop across the filter becomes too high and makes isokinetic sampling difficult to maintain, the filter may be replaced in the midst of a sample run. It is recommended that another complete filter assembly be used rather than attempting to change the filter itself. Before a new filter assembly is installed, conduct a leak check (see paragraph (i)(D)(2) of this subdivision). The total particulate weight shall include the summation of all filter assembly catches.

A single train shall be used for the entire sample run, except in cases where simultaneous sampling is required in 2 or more separate ducts, at 2 or more different locations within the same duct, or where equipment failure necessitates a change of trains. In all other situations, the use of 2 or more trains shall be subject to the approval of the department.

Note that when 2 or more trains are used, separate analyses of the front-half catches from the individual trains may be combined, as may the impinger catches, and 1 analysis of the front-half catch and 1 analysis of impinger catch may be performed. Consult with the department for details concerning the calculation of results when 2 or more trains are used.

At the end of the sample run, turn off the coarse adjust valve, remove the probe and nozzle from the stack, turn off the pump, record the final dry-gas meter reading, and conduct a post-test leak check, as outlined in paragraph (i)(D)(3). Also, leak check the pitot lines as described in method 2, section 3.1; the lines shall pass this leak check to validate the velocity head data.

(F) Calculation of percent isokinetic. Calculate percent isokinetic (see subdivision (f) of this rule) to determine whether the run was valid or whether another test run should be made. If there was difficulty in maintaining isokinetic rates due to source conditions, consult with the department for possible variance on the isokinetic rates.

(ii) Sample recovery. Proper cleanup procedure begins as soon as the probe is removed from the stack at the end of the sampling period. Allow the probe to cool. When the probe can be safely handled, wipe off all external particulate matter near the tip of the probe nozzle and place a cap over it to prevent losing or gaining particulate matter. Do not cap off the probe tip tightly while the sampling train is cooling down as this creates a vacuum in the filter holder and draws water from the impingers into the filter holder.

Before moving the sample train to the cleanup site, remove the probe from the sample train, wipe off the silicone grease, and cap the open outlet of the probe. Be careful not to lose any condensate that might be present. Wipe off the silicone grease from the filter inlet where the probe was fastened and cap it. Remove the umbilical cord from the last impinger and cap the impinger. If a flexible line is used between the first impinger or condenser and the filter holder, disconnect the line at the filter holder and let any condensed water or liquid drain into the impingers or condenser. After wiping off the silicone grease, cap off the filter holder outlet and impinger inlet. Ground-glass stoppers, plastic caps, or serum caps may be used to close these openings.

Transfer the probe and filter-impinger assembly to the cleanup area. This area shall be clean and protected from the wind so that the chances of contaminating or losing the sample are minimized.

Save a portion of the solvent used for cleanup as a blank. Take 200 ml of this solvent directly from the wash bottle being used and place it in a glass sample container labeled "solvent blank."

Inspect the train prior to and during disassembly and note any abnormal conditions. Treat the samples as follows:

Container Nos. 1, 1A. Carefully remove the filters from the filter holders and place in their identified containers. Use a pair of tweezers or clean disposable surgical gloves, or both, to handle the filters. Carefully transfer to the container any particulate matter or filter fibers, or both, that adhere to the filter holder gasket by using a dry nylon bristle brush or sharp-edged blade, or both. Seal the container.

Container No. 2. Taking care to see that dust on the outside of the probe or other exterior surfaces does not get into the sample, the testor shall quantitatively recover from particulate matter or any condensate from the nozzle, probe fitting, probe liner, and from both filter holders by washing these components with solvent and placing the wash in a glass container.

Perform the solvent rinses as follows:

Carefully remove the probe nozzle and clean the inside surface by rinsing with solvent from a wash bottle and brushing with a nylon bristle brush. Brush until the solvent rinse shows no visible particles and then make a final rinse of the inside surface with solvent.

Brush and rinse the inside parts of the Swagelok fitting with solvent in a similar way until no visible

particles remain.

Rinse the probe liner with solvent by tilting and rotating the probe while squirting solvent into its upper end so that all inside surfaces are wetted with acetone. Let the solvent drain from the lower end into the sample container. A glass or polyethylene funnel may be used to aid in transferring liquid washes to the container. Follow the solvent rinse with a probe brush. Hold the probe in an inclined position and squirt solvent into the upper end as the probe brush is being pushed with a twisting action through the probe; hold a sample container underneath the lower end of the probe and catch any solvent and particulate matter that is brushed from the probe. Run the brush through the probe 3 or more times until no visible particulate matter is carried out with the solvent or until none remains in the probe liner on visual inspection. With stainless steel or other metal probes, run the brush through, in the above prescribed manner, not less than 6 times, since metal probes have small crevices in which particulate matter can be entrapped. Rinse the brush with solvent and quantitatively collect these washings in the sample container. After the brushing, make a final solvent rinse of the probe as described above.

It is recommended that 2 people be used to clean the probe to minimize sample losses. Between sampling runs, keep brushes clean and protected from contamination.

After ensuring that all joints have been wiped clean of silicone grease, clean the inside of both filter holders by rubbing the surfaces with a nylon bristle brush and rinsing with solvent. Rinse each surface 3 times, or more if needed, to remove visible particulate. Make a final rinse of the brush and filter holder.

After all solvent washings and particulate matter have been collected in the sample container, tighten the lid on the sample container so that solvent will not leak out when it is shipped to the laboratory. Mark the height of the fluid level to determine whether or not leakage occurred during transport. Label the container to clearly identify its contents.

Container No. 3. Note the color of the indicating silica gel to determine if it has been completely spent and make a notation of its condition. Transfer the silica gel from the third impinger to its original container and seal. A funnel may make it easier to pour the silica gel without spilling it. A rubber policeman may be used as an aid in removing the silica gel from the impinger. It is not necessary to remove the small amount of dust particles that adhere to the impinger wall and are difficult to remove. Since the gain in weight is to be used for moisture calculations, do not use any water or other liquids to transfer the silica gel. If a balance is available in the field, follow the procedure for container No. 3 in paragraph (iii) of this subdivision. Impinger water. Treat the impingers as follows: Make a notation of any color or film in the liquid catch. Measure the liquid that is in the first 2 impingers to within  $\pm 1$  ml by using a graduated cylinder or by weighing it to within  $\pm 1.0$  g by using a balance if none is available. Record the volume or weight of liquid present. This information is required to calculate the moisture content of the effluent gas.

Discard the liquid after measuring and recording the volume or weight, unless analysis of the impinger catch is required (see subdivision (b)(i)(G) of this rule).

If a different type of condenser is used, measure the amount of moisture condensed either volumetrically or gravimetrically. Whenever possible, containers shall be shipped in a manner that keeps them upright at all times.

(iii) Analysis. Record the data required on a sheet such as the one shown in figure 106. Handle each sample container as follows:

Container Nos. 1, 1A. Analyze and report each filter separately. Transfer the filter and any loose particulate from the sample container to a tared-glass weighing dish. Dry the filter in an oven at 105 degrees Centigrade (220 degrees Fahrenheit) for a minimum of 2 hours, cool for at least 1 hour in a desiccator containing anhydrous calcium sulfate, and weigh and record its weight to the nearest 0.1 mg. During the weighing, the filter shall not be exposed to the laboratory atmosphere for a period of more than 2 minutes or a relative humidity above 50%. Procedures, other than those specified, that account for relative humidity effects may be used, subject to the approval of the department. The method used for the drying and weighing of filters shall be consistent before and after the test.



Container No. 2. Note the level of liquid in the container and confirm on the analysis sheet whether or not leakage occurred during transport. If a noticeable amount of leakage has occurred, either void the sample or use methods, subject to the approval of the department, to correct the final results.

Measure the liquid in this container either volumetrically to  $\pm 1$  ml or gravimetrically to  $\pm 1.0$  g. Transfer the contents to a tared 250-ml beaker and evaporate to dryness either at ambient temperature and pressure for acetone or at 95 degrees Centigrade (203 degrees Fahrenheit) in an oven for distilled water. Then subject the sample to 250 degrees Centigrade (482 degrees Fahrenheit) in an oven for 2 to 3 hours. Desiccate for 24 hours and weigh to a constant weight. Report the results to the nearest 0.1 mg.

Container No. 3. Weigh the spent silica gel, or silica gel plus impinger, to the nearest 0.5 g using a balance. This step may be conducted in the field.

"Solvent blank" container. Measure solvent in this container either volumetrically or gravimetrically. Transfer the contents to a tared 250-ml beaker and evaporate to dryness either at ambient temperature and pressure for acetone or at 95 degrees Centigrade (203 degrees Fahrenheit) in an oven for distilled water. Then subject the sample to 250 degrees Centigrade (482 degrees Fahrenheit) in an oven for 2 to 3 hours. Desiccate for 24 hours and weigh to a constant weight. Report the results to the nearest 0.1 mg.

If acetone is used, the contents of container No. 2, as well as the acetone blank container, may be evaporated at temperatures higher than ambient. If evaporation is done at an elevated temperature, the temperature shall be closely supervised, and the contents of the beaker shall be swirled occasionally to maintain an even temperature. Use extreme care, as acetone is highly flammable and has a low flash point.

(e) Calibration. Maintain a laboratory log of all calibrations. Calibrations shall comply with all of the following provisions:

(i) Probe nozzle. Probe nozzles shall be calibrated before their initial use in the field. Using a micrometer, measure the inside diameter of the nozzle to the nearest 0.025 mm (0.001 in.). Make 3 separate measurements using different diameters each time and obtain the average of the measurements. The difference between the high and low numbers shall not exceed 0.1 mm (0.004 in.). When nozzles become nicked, dented, or corroded, they shall be reshaped, sharpened, and recalibrated before use. Each nozzle shall be permanently and uniquely identified.

(ii) Pitot tube. The type S pitot tube assembly shall be calibrated according to the procedure outlined in section 4 of method 2.

(iii) Metering system. Before its initial use in the field, the metering system shall be calibrated according to the procedure outlined in APTD-0576. Instead of physically adjusting the dry-gas meter dial readings to correspond to the wet-test meter readings, calibration factors may be used to mathematically correct the gas meter dial readings to the proper values. Before calibrating the metering system, it is suggested that a leak check be conducted. For metering systems having diaphragm or rotary pumps, the normal leak check procedure will not detect leakages within the pump. For these cases, the following leak check procedure is suggested: Make a 10-minute calibration run at 0.00057 m<sup>3</sup>/min (0.02 cfm); at the end of the run, take the difference of the measured wet-test meter and dry-gas meter volumes; divide the difference by 10 to get the leak rate. The leak rate shall not exceed 0.00057 m<sup>3</sup>/min (0.02 cfm).

After each field use, the calibration of the metering system shall be checked by performing 3 calibration runs at a single, intermediate orifice setting, based on the previous field test, with the vacuum set at the maximum value reached during the test series. To adjust the vacuum, insert a valve between the wet-test meter and the inlet of the metering system. Calculate the average value of the calibration factor. If the calibration has changed by more than 5%, recalibrate the meter over the full range of orifice settings, as outlined in APTD-0576.

Alternatively, a spirometer may be substituted for a wet-test meter in the above mentioned calibration procedures. Alternative procedures, such as using the orifice meter coefficients, may be used, subject to the approval of the department.

If the dry-gas meter coefficient values obtained before and after a test series differ by more than 5%, the test series shall be performed using whichever meter coefficient value (before or after) gives the lower value of total sample volume.

(iv) Probe heater calibration. The probe heating system shall be calibrated before its initial use in the field according to the procedures outlined in APTD-0576. Probes constructed according to APTD-0581 need not be calibrated if the calibration curves in APTD-0576 are used.

(v) Temperature gauges. Use the procedure in section 4.3 of method 2 to calibrate in-stack temperature gauges. Dial thermometers, such as those used for the dry-gas meter and condenser outlet, shall be calibrated against mercury-in-glass thermometers.

(vi) Leak check of metering system shown in figure 103. That portion of the sampling train from the pump to the orifice meter shall be leak checked before initial use and after each shipment. Leakage after the pump will result in less volume being recorded than is actually sampled. The following procedure is suggested (see figure 107): Close the main valve on the meter box. Insert a 1-hole rubber stopper with rubber tubing attached into the orifice exhaust pipe. Disconnect and vent the low side of the orifice manometer. Close off the low side orifice tap. Pressurize the system to 13 to 18 cm (5 to 7 in.) water column by blowing into the rubber tubing. Pinch off the tubing and observe the manometer for 1 minute. A loss of pressure on the manometer indicates a leak in the meter box; leaks, if present, shall be corrected.

(vii) Barometer. Calibrate against a mercury barometer.

(f) Calculations. When carrying out calculations, retain at least 1 extra decimal figure beyond that of the acquired data. Round off figures after the final calculation. Other forms of the equations may be used if they give equivalent results. All of the following provisions apply to calculations:

(i) Nomenclature:

$A_n$  = Cross-sectional area of nozzle,  $m^2$  ( $ft^2$ )

$A$  = Cross-sectional area of stack or flue at the point of sampling,  $ft.^2$ .

$B_{ws}$  = Water vapor in the gas stream, proportion by volume, expressed as a fraction.

$B_{wi}$  = Percent water vapor in gas entering source particulate control device, determined by method 4.

$B_{wo}$  = Percent water vapor in gas exiting source particulate control device.

$C_a$  = Wash blank residue concentration,  $mg/g$ .

$C_s$  = Concentration of particulate matter in stack gas, pounds per 1,000 pounds of actual stack gas.

$C_{sD}$  = Concentration of particulate matter in stack gas, moisture excluded, pounds per 1,000 pounds of dry stack gas.

$C_{s50}$  = Concentration of particulate matter corrected to 50% excess air, pounds per 1,000 pounds of stack gas.

$C_{s50D}$  = Concentration of particulate matter corrected to 50% excess air, excluding any water addition from a collector, pounds per 1,000 pounds of stack gas.

$E$  = Mass emission rate of particulate,  $lb/hr$ .

$F_{50}$  = Concentration conversion factor to 50% excess air with no moisture alterations in exhaust.

$F_{50D}$  = Concentration conversion factor to 50% excess air, excluding any moisture added to exhaust gas by pollution collection system.

$F_D$  = Concentration conversion factor to dry basis, excluding any water in the stack gas.

I = Percent of isokinetic sampling.

$L_a$  = Maximum acceptable leakage rate for either a pretest leak check or for a leak check following a component change; equal to 0.00057 m<sup>3</sup>/min (0.02 cfm) or 4% of the average sampling rate, whichever is less.

$L_i$  = Individual leakage rate observed during the leak check conducted BEFORE the "ith" component change (i = 1, 2, 3 . . . . n), m<sup>3</sup>/min (cfm).

$L_p$  = Leakage rate observed during the post-test leak check, m<sup>3</sup>/min (cfm).

$M_d$  = Molecular weight of dry stack gas, g/g mole (lb/lb-mole), calculated by method 3, equation 3-2, using data from integrated method 3.

$m_n$  = Total amount of particulate matter collected, mg.

$M_w$  = Molecular weight of water, 18.0 g/g-mole (18.0 lb/lb-mole).

$m_a$  = Mass of residue of solvent after evaporation, mg.

$m_g$  = Total weight of gas samples through nozzle, lb.

$P_{bar}$  = Barometric pressure at the sampling site, mm Hg (in. Hg).

$P_s$  = Absolute stack gas pressure.

$P_{std}$  = Standard absolute pressure, 760 mm Hg (29.92 in. Hg).

R = Ideal gas constant, 0.06236 mm Hg-m<sup>3</sup>/°K-g-mole (21.85 in. Hg-ft<sup>3</sup>/°R-lb-mole).

$T_m$  = Absolute average dry-gas meter temperature (see figure 104), °K (°R).

$T_s$  = Absolute average stack gas temperature (see figure 104), °K (°R).

$T_{std}$  = Standard absolute temperature, 294.1 °K (530 °R).

$V_a$  = Volume of solvent blank, ml.

$V_{aw}$  = Volume of solvent used in wash, ml.

$V_{lc}$  = Total volume of liquid collected in impingers and silica gel (see figure 106), ml.

$V_m$  = Volume of gas sample as measured by dry-gas meter, dcm (dcf).

$V_{m(std)}$  = Volume of gas sample measured by the dry-gas meter, corrected to standard conditions, dscm (dscf).

$V_{w(std)}$  = Volume of water vapor in the gas sample, corrected to standard conditions, scm (scf).

$V_s$  = Stack gas velocity, calculated by method 2, equation 2-9, using data obtained from method 5, m/sec (ft./sec).

$W_a$  = Weight of residue in solvent wash, mg.

Y = Dry-gas meter calibration factor.

$\Delta H$  = Average pressure differential across the orifice meter (see figure 104), mm H<sub>2</sub>O (in. H<sub>2</sub>O).

%O<sub>2</sub> = Percent oxygen in stack gas by volume (dry basis).

%N<sub>2</sub> = Percent nitrogen in stack gas by volume (dry basis).

$\rho_a$  = Density of solvent, mg/ml.

$\rho_{s(std)}$  = Density of all sampled gas at standard conditions, lb/ft.<sup>3</sup>.

$\rho_w$  = Density of water, 0.9982 g/ml (0.002201 lb/ml).

$\theta$  = Total sample time, min.

$\theta_1$  = Sample time, interval, from the beginning of a run until the first component change, min.

$\theta_i$  = Sampling time interval, between 2 successive component changes beginning with the interval between the first and second changes, min.

$\theta_p$  = Sampling time interval, from the final (nth) component change until the end of the sampling run, min.

13.6 = Specific gravity of mercury.

60 = Sec/min.

100 = Conversion to percent.

386.9 = Cubic feet per lb-mole of ideal gas at standard conditions.

453.6 = Conversion of pounds to grams.

3600 = Conversion of hours to sec.

1000 = Conversion of 1000 lb units to lb units.

(ii) Average the dry-gas meter temperature and average the orifice pressure drop. See data sheet (figure 104).

(iii) Dry gas volume. Correct the sample volume measured by the dry-gas meter to standard conditions (21.1 degrees Centigrade, 760 mm Hg or 70 degrees Fahrenheit, 29.92 in. Hg) by using equation 5-1.

equation 5-1

$$V_{m(std)} = \frac{V_m Y T_{std} (P_{bar} + \Delta H/13.6)}{T_m P_{std}} = K_1 V_m Y \frac{(P_{bar} + \Delta H/13.6)}{T_m}$$

Where:

$K_1$  = 0.3869 °K/mm Hg for metric units.  
= 17.71 °R/in. Hg for English units.

Equation 5-1 can be used as written. However, if the leakage rate observed during any of the mandatory leak checks (for example, the post-test leak check or leak checks conducted prior to component changes) exceeds  $L_a$ , equation 5-1 shall be modified as follows:

(A) Case I. No component changes made during sampling run. In this case, replace  $V_m$  in equation 5-1 with the expression:

$$V_m - (L_p - L_a)\theta$$

(B) Case II. One or more component changes made during the sampling run. In this case, replace  $V_m$  in equation 5-1 by the expression:

$$V_m - (L_1 - L_a)\theta_1 - \sum_{i=2}^n (L_i - L_a)\theta_i - (L_p - L_a)\theta_p$$

and substitute only for those leakage rates ( $L_i$  or  $L_p$ ) that exceed  $L_a$ .

(iv) Volume of water vapor.

equation 5-2

$$V_{w(std)} = V_{1c} (P_w/M_w) (R T_{std}/P_{std}) = K_2 V_{1c}$$

Where:

$K_2 = 0.001338$  mm/ml for metric units.  
 $= 0.04733$  ft<sup>3</sup>/ml for English units

(v) Moisture content.

equation 5-3

$$B_{ws} = V_{w(std)} / (V_{m(std)} + V_{w(std)})$$

In saturated or water droplet-laden gas streams, 2 calculations of the moisture content of the stack gas shall be made: 1 from the impinger analysis (equation 5-3), and a second from the assumption of saturated conditions. The lower of the 2 values of Bws shall be considered correct. The procedure for determining the moisture content based upon assumption of saturated conditions is given in the note of section 1.2 of method 4. For the purpose of this method, the average stack gas temperature from figure 104 may be used to make the determination, if the accuracy of the in-stack temperature sensor is  $\pm 1$  degree Centigrade (2 degrees Fahrenheit).

(vi) Solvent blank concentration.

equation 5-4

$$C_a = m_a / (V_a P_a)$$

(vii) Solvent wash blank.

equation 5-5

$$W_a = C_a V_{aw} P_a$$

(viii) Total particulate weight. Determine the total particulate catch from the sum of the weights obtained from containers 1, 1A, and 2 less the wash solvent blank (see figure 106).

Refer to subdivision (d)(i)(E) of this rule to assist in the calculation of results involving 2 or more pairs of filters or 2 or more sampling trains.

(ix) Sampled gas density. Determine the density of the gas sampled from the stack, at standard conditions (lb/ft.<sup>3</sup>).

equation 5-6

$$P_{s(std)} = (M_d (1 - B_{ws}) + M_w B_{ws}) / 386.9$$

(x) Total weight of gas sampled (lbs).

equation 5-7

$$m_g = (V_{m(std)} + V_{w(std)}) P_{s(std)}$$

(xi) Particulate concentration (lbs/1000 lbs).

equation 5-8

$$C_s = m_n / (453.6 m_g)$$

(xii) Excess air and moisture correction factors:

(A) Correction factor to 50% excess air for those sources with or without any particulate collector where no increase in moisture content of the exhaust gas occurs after the process and before the point of sampling.

equation 5-9

$$F_{50} = \frac{M_d + 18 B_{wo}/(100 - B_{wo})}{0.1826 \%N_2 - 2.0592 \%O_2 + M_d + 18 B_{wo} / (100 - B_{wo})}$$

(B) Correction factor to 50% excess air for those sources with a wet collection device (scrubber) that increases the moisture content of the exhaust gas after the process and before the point of sampling.

equation 5-10

$$F_{50D} = \frac{M_d + 18 B_{wo}/(100 - B_{wo})}{0.1826 \%N_2 - 2.0592 \%O_2 + M_d + 18 B_{wi} / (100 - B_{wi})}$$

(C) Correction factor to convert the actual concentration,  $C_s$ , to dry conditions.

equation 5-11

$$F_D = \frac{M_d + 18 B_{wo}/(100 - B_{wo})}{M_d}$$

(xiii) Converted particulate concentrations, where applicable under the department's rules or permit.

equation 5-12

$$C_{s50} = C_s F_{50}$$

equation 5-13

$$C_{s50D} = C_s F_{50D}$$

equation 5-14

$$C_{s0} = C_s F_D$$

(xiv) Mass emission rate (lb/hr).

equation 5-15

$$E = \frac{3600 A V_s C_s P_s T_{std} P_{s(std)}}{1000 T_s P_{std}} = K_3 A V_s C_s P_s P_{s(std)} / T_s$$

Where:

$K_3 = 63.77$  for English units.

(xv) Isokinetic variation:

(A) Calculation from raw data.

equation 5-16

$$I = \frac{100 T_s (K_4 V_{lc} + (V_m / T_m)(P_{bar} + \Delta H / 13.6))}{60 \theta V_s P_s A_n}$$

Where:

$K_4 = 0.003458$  mm Hg -  $m^3$ ml -  $^{\circ}$ K for metric units.

$= 0.002672$  in. Hg -  $ft.^3$ /ml -  $^{\circ}$ R for English units.

(B) Calculation from intermediate values.

$$I = \frac{T_s V_{m(std)} P_{std} 100}{T_{std} V_s \theta A_n P_s 60 (1 - B_{ws})} = K_5 \frac{T_s V_{m(std)}}{P_s V_s A_n \theta (1 - B_{ws})}$$

Where:

$K_5 = 4.307$  for metric units.  
 $= 0.09409$  for English units.

(xvi) Acceptable results. If  $90\% \leq I \leq 110\%$ , the results are acceptable. If the results are low in comparison to the standard and  $I$  is beyond the acceptable range, or if  $I$  is less than 90%, the department may opt to accept the results. Otherwise, reject the results and repeat the test.

(g) Bibliography:

(i) Federal Register, Volume 42, No. 160, Part 60, Chapter 1, Title 40, Appendix A, Method 5. August 18, 1977.

(ii) Martin, Robert M. Construction Details of Isokinetic Source Sampling Equipment. Environmental Protection Agency. Research Triangle Park, N.C. APTD-0581. April, 1971.

(iii) Rom, Jerome J. Maintenance, Calibration, and Operation of Isokinetic Source Sampling Equipment. Environmental Protection Agency. Research Triangle Park, N.C. APTD-0576. March, 1972.

(iv) Shigehara, R. T. "Adjustments in the EPA Nomograph for Different Pitot Tube Coefficients and Dry Molecular Weights." Stack Sampling News 2:4-11. October, 1974.

(v) Guidelines for Source Testing of Particulate. Michigan Department of Natural Resources, Air Quality Division. June 1, 1977.

History: 1985 MR 2, Eff. Feb. 22, 1985; 1992 MR 9, Eff. Oct. 31, 1992; 2002 MR 5, Eff. Mar. 19, 2002; Corrected 2004 MR 18, Oct. 15, 2004.

### **R 336.2013 Reference test method 5D.**

Rule 1013. Reference test method 5D, testing of steel manufacturing sources, reads as follows:

(a) General description. Emission testing procedures shall follow the methodology specified in R 336.2004(1)(c) and (d) and R 336.2012, unless otherwise provided in this rule.

(b) Coke battery pushing emission control equipment outlet test procedure for scrubbers. Outlet emission tests for any scrubber emission control equipment controlling coke battery emissions shall be conducted as follows:

(i) The pushing emission control system is operated on a batch type process and shall be tested as such using the reference test methods specified in subdivision (a) of this rule.

(ii) Each sampling point shall be sampled for 1 cycle operation, which is defined as beginning when the coke guide and snorkels are engaged and continuing until the quench car leaves the hood.

(iii) For a shed, the sampling period shall begin with the first movement of coke and shall end when the car enters the quench tower.

(iv) Integrated gas samples shall be taken over the entire test period. The samples shall be analyzed for carbon monoxide, carbon dioxide, oxygen, and nitrogen by means of an Orsat analyzer. The sampling and sample analysis shall be performed in accordance with R 336.2004(1)(c). The average values from the 3 samples shall be used in determining the dry molecular weight of the exhaust gas. If a complete test is not performed during the day, at least 1 sample shall be taken.

(v) Based on design and previous data, saturated conditions shall be assumed. The moisture content shall be calculated as per R 336.2004(1)(d), based on stack conditions during the preliminary and sampling traverses.

(vi) The stack sampling equipment and procedures as described in method 5C shall be used in performing a particulate emission test, with the following variations:

(A) Due to the varying time required for pushing operations, an integer sampling time increment shall not be required.

(B) Because of the shorter sampling periods at each sampling point, a specific gas volume cannot be guaranteed. Therefore, an average sampling rate of not less than 0.90 dry standard cubic feet per minute shall be used during each sampling run.

(C) A stainless steel probe liner after the nozzle may be used.

(D) Glass or glass-lined stainless steel tubing and a glass cyclone between the probe and filter holder may be used.

(E) The probe and filter heating system may be heated at  $248 \pm 25$  degrees Fahrenheit.

(c) Basic oxygen furnace primary emissions control equipment outlet test procedure. Outlet emission tests for any emission control equipment controlling only the primary emissions from a basic oxygen furnace shall be conducted as follows:

(i) The testing program shall consist of 3 valid sampling runs. A sampling run is the composite of those portions of 4 heats starting with oxygen blowing and ending not more than 180 seconds following the last oxygen blow or the beginning of the tap, whichever occurs first. Each process cycle shall be used to obtain the sample for 1 quadrant of the traverse.

(ii) When testing a wet scrubber outlet, saturated conditions shall be assumed and moisture content shall be calculated based on stack conditions during the preliminary and sampling traverses.

(iii) The particulate emission rate shall be determined as specified in reference test method 5C, with the following variations:

(A) A stainless steel probe liner after the nozzle may be used.

(B) Glass or glass-lined stainless steel tubing and a glass cyclone between the probe and filter holder may be used.

(C) The probe and filter heating system may be heated to  $248 \pm 25$  degrees Fahrenheit.

(d) Basic oxygen furnace secondary emissions control equipment outlet test procedure. Outlet emission tests for any emission control equipment controlling only the secondary emissions from a basic oxygen furnace shall be conducted as follows:

(i) The testing program shall consist of 3 valid sampling runs. A sampling run shall be defined as the composite of the following portions of 4 heats:

(A) Charging.

(B) Tapping.

(C) Turndown.

(D) Slagging.

(E) The first 5 minutes of oxygen blowing for those systems with a separate secondary collector.

(ii) When testing a wet scrubber outlet, saturated conditions shall be assumed and moisture content shall be calculated based on stack conditions during the preliminary and sampling traverses.

(iii) The particulate emission rate shall be determined as specified in reference test method 5C, with the following variations:

(A) A stainless steel probe liner after the nozzle may be used.

(B) Glass or glass-lined stainless steel tubing and a glass cyclone between the probe and filter holder may be used.

(C) The probe and filter heating system may be heated to  $248 \pm 25$  degrees Fahrenheit.

(e) Basic oxygen furnace primary and secondary emissions control equipment outlet test procedures. Outlet emission tests for any emission control equipment controlling both the primary and secondary emissions from a basic oxygen furnace shall be conducted as follows:

(i) One vessel:

(A) For testing of primary control equipment that captures secondary emissions from a single vessel, the testing program shall consist of 3 valid sampling runs. A sampling run is the composite of the following portions of 8 heats:

(1) Charging.

(2) Oxygen blowing.



- (3) Tapping.
- (4) Turndown.
- (5) Slagging.

Four heats are to be sampled only during oxygen blowing, with each heat used to obtain the sample from 1 quadrant. The remaining 4 heats are to be sampled only during the portions of the heat other than oxygen blowing, with each heat used to obtain the sample from 1 quadrant.

(B) When testing a wet scrubber outlet, saturated conditions shall be assumed and moisture content shall be calculated based on stack conditions during the preliminary and sampling traverses.

(C) The particulate emission rate shall be determined as specified in reference test method 5C, with the following variations:

- (1) A stainless steel probe liner after the nozzle may be used.
- (2) Glass or glass-lined stainless steel tubing and a glass cyclone between the probe and filter holder may be used.
- (3) The probe and filter heating system may be heated to  $248 \pm 25$  degrees Fahrenheit.

(ii) More than one vessel:

(A) For testing of control equipment that captures both primary and secondary emissions from more than 1 vessel, the testing program shall consist of 3 valid sampling runs. A sampling run is the composite of the following portions of 4 heats for 1 or more vessels:

- (1) Charging.
- (2) Oxygen blowing.
- (3) ) Tapping.
- (4) Turndown.
- (5) Slagging.

At least 1 heat shall be used to obtain the sample from each quadrant of the traverse.

(B) When testing a wet scrubber outlet, saturated conditions shall be assumed and moisture content shall be calculated based on stack conditions during the preliminary and sampling traverses.

(C) The particulate emission rate shall be determined as specified in reference test method 5C, with the following variations:

- (1) A stainless steel probe liner after the nozzle may be used.
- (2) Glass or glass-lined stainless steel tubing and a glass cyclone between the probe and filter holder may be used.
- (3) The probe and filter heating system may be heated to  $248 \pm 25$  degrees Fahrenheit.

(f) Blast furnace casthouse air-cleaning device outlet test procedure. Outlet emission tests for any air-cleaning device controlling fugitive emissions from a blast furnace casthouse shall be conducted as follows:

(i) The testing program shall consist of 3 sampling runs. A sampling run shall be performed during a 2-hour period, sampling only when casting takes place. If 50 dry standard cubic feet are not sampled during this period, the sampling run shall be extended so as to fulfill this condition.

(ii) The particulate emission rate shall be determined as specified in reference test method 5C, with the following variations:

- (A) A stainless steel probe liner after the nozzle may be used.
- (B) Glass or glass-lined stainless steel tubing and a glass cyclone between the probe and filter holder may be used.

(C) The probe and filter heating system may be heated to  $248 \pm 25$  degrees Fahrenheit.

(g) Coke oven combustion stack test procedures. Emissions from any coke oven combustion stack shall be tested as follows:

(i) The testing program shall consist of 3 valid sampling runs.

(ii) Saturated conditions shall be assumed for stacks controlled by wet scrubbers. The moisture content shall be calculated as per R 336.2004(1)(d) based on stack conditions during the preliminary and

sampling traverses.

(iii) The stack sampling equipment and procedures described in method 5C shall be used in performing a particulate emission test with the following variations:

(A) A stainless steel probe liner after the nozzle may be used.

(B) Heated flexible teflon tubing and a glass cyclone between the probe and filter holder may be used.

(C) The probe and filter heating system may be heated at  $248 \pm 25$  degrees Fahrenheit.

(D) All filters shall be cooled and stored in a dessicator previous to weighing. Exposure to the ambient air shall be minimized to the extent that it is practical. This same procedure shall be used if any subsequent weighing is necessary.

(iv) The sampling time shall correspond to a minimum of 5 coke oven pushes per battery.

(h) Coke oven coal preheater scrubber outlet test procedures. Outlet emission tests for any scrubber emission control equipment controlling emissions from a coke oven coal preheater shall be conducted as follows:

(i) The testing program shall consist of 3 valid sampling runs.

(ii) Based on design and previous data, saturated conditions shall be assumed. The moisture content shall be calculated as per R 336.2004(1)(d) based on stack conditions during the preliminary and sampling traverses.

(iii) The stack sampling equipment and procedures described in method 5C shall be used in performing a particulate emission test with the following variations:

(A) A stainless steel probe liner after the nozzle may be used.

(B) Glass or glass-lined stainless steel tubing and a glass cyclone between the probe and filter holder may be used.

(C) The probe and filter heating system may be heated at  $248 \pm 25$  degrees Fahrenheit.

(i) Electric arc furnace stack test procedures. Emissions from any electric arc furnace stack shall be tested as follows:

(i) The testing program shall consist of 3 valid sampling runs. A sampling run is the time beginning when the roof is placed on the furnace, after the first charge, and ending with the time when the roof is removed, just prior to tapping.

(ii) The particulate emission rate shall be determined as specified in reference test method 5C, with the following exceptions:

(A) A stainless steel probe liner after the nozzle may be used.

(B) Glass or glass-lined stainless steel tubing and a glass cyclone between the probe and filter holder may be used.

(C) The probe and filter heating system may be heated to  $248 \pm 25$  degrees Fahrenheit.

(D) The emission rate for any furnace controlled by a positive pressure baghouse, or by a baghouse exhausted by more than 5 stacks, shall be determined as specified in R 336.2014.

(j) Sinter plant gravel bed filter test procedures. Emissions from any gravel bed filter emission control equipment controlling emissions from a sinter plant shall be tested as follows:

(i) The testing program shall consist of 3 valid sampling runs.

(ii) The stack sampling equipment and procedures described in method 5C shall be used in performing a particulate emission test with the following variations:

(A) A stainless steel probe liner after the nozzle may be used.

(B) Glass or glass-lined stainless steel tubing and a glass cyclone between the probe and filter holder may be used.

(C) The probe and filter heating system may be heated at  $248 \pm 25$  degrees Fahrenheit.

(k) Miscellaneous. During each stack test performed, the owner or operator shall provide a representative of the department access to production data and other parameters that are necessary for determining compliance.

(l) Sample volume. The minimum volume per sample shall be 50 cubic feet of dry gas corrected to standard conditions, 70 degrees Fahrenheit, 29.92 inches of mercury, unless specified otherwise in the provisions of this rule.

(m) Opacity tests. During each stack test performed, simultaneous visible emission evaluations shall be conducted according to the reference test method specified in R 336.1303 for the process being tested.

(n) Operating conditions. During each run of a stack test, the facility to be tested shall be operated at a batch or other similar production level which is representative of the actual level during the preceding 3 months before the first day of the test, unless the department approves or specifies alternate acceptable operating conditions.

(o) Compliance. Compliance with any mass emission standard shall be determined by averaging 3 test runs using all test procedures specified for the tested process in this rule.

History: 1985 MR 2, Eff. Feb. 22, 1985; 2002 MR 5, Eff. Mar. 19, 2002.

### **R 336.2014 Reference test method 5E.**

Rule 1014. Reference test method 5 E, determination of particulate matter emissions from positive pressure fabric filters, reads as follows:

(a) The principle, applicability, and performance test criteria are as follows:

(i) Principle. Particulate matter is withdrawn isokinetically from the source and collected on a glass fiber filter maintained at a temperature at or above the exhaust gas temperature up to a nominal 248 ±25 degrees Fahrenheit. The particulate mass, which includes any material that condenses at or above the filtration temperature, is determined gravimetrically after the removal of uncombined water.

(ii) Applicability. This method is applicable for the determination of particulate emissions from the stationary sources as identified in table 31 of R 336.1331. The method is also applicable when specifically provided for in the department's rules, orders, a permit to install, or a permit to operate.

(iii) Performance test criteria:

(A) A performance test shall consist of a minimum of 3 separate samples of a specific air contaminant conducted within a 36-hour period, unless otherwise authorized by the department. Each of the 3 separate samples shall be obtained while the source is operating at a similar production level. For the purpose of determining compliance with an applicable emission limit, rule, or permit condition, the arithmetic mean of results of the 3 samples shall apply. If a sample is accidentally lost or conditions occur in which 1 of the 3 samples must be discontinued because of forced shutdown, failure of an irreplaceable portion of the sampling train, extreme meteorological conditions, or other circumstances beyond the owner's or operator's control, compliance may, upon the approval of the department, be determined using the arithmetic mean of the results of 2 samples.

(B) For any source that is subject to an emission limitation calculated to 50% excess air, the multipoint, integrated sampling procedure of R 336.2004(1)(c) shall be used for gas analysis. For all other sources that require a determination of the molecular weight of the exhaust, any optional sampling procedure of R 336.2004(1)(c) may be used. Alternatives or modifications to procedures are subject to the approval of the department.

(C) The minimum volume per sample shall be 30 cubic feet actual gas. Minimum sample time shall be 60 minutes, which may be continuous or a combination of shorter sampling periods for sources that operate in a cyclic manner. Smaller sampling times or sample volumes, when necessitated by process variables or other factors, may be approved by the department.

(D) For any source whose emission control device alters the moisture content of the exhaust gas, a moisture determination shall be performed in a location upstream from the emission control device and in accordance with R 336.2004(1)(d) or an alternative method approved by the department.

(b) The following provisions apply to apparatus:

(i) Sampling train. A schematic of the sampling train used in this method is shown in figure 103. Construction details for many, but not all, of the train components are given in APTD-0581 (subdivision (g)(ii) of this rule). For changes from the APTD-0581 document and for allowable modifications to figure 103, consult with the department.

The operating and maintenance procedures for many, but not all, of the sampling train are described in APTD-0576 (subdivision (g)(iii) of this rule). Since correct usage is important in obtaining valid results, all users shall read APTD-0576 and adopt the applicable operating and maintenance procedures outlined in it, unless otherwise specified in these rules. The sampling train consists of the following components:

(A) Probe nozzle. Stainless steel (316) or glass with sharp, tapered leading edge. The angle of taper shall be less than 30 degrees and the taper shall be on the outside to preserve a constant internal diameter. The probe nozzle shall be of the button-hook design, unless otherwise specified by the department. If made of stainless steel, the nozzle shall be constructed from seamless tubing. Other materials of construction may be used, subject to the approval of the department.

A range of nozzle sizes suitable for isokinetic sampling shall be available, for example, 0.32 to 1.27 cm (1/8 to 1/2 in.) or larger if higher volume sampling trains are used inside diameter (ID) nozzles in increments of 0.16 cm (1/16 in.). Each nozzle shall be calibrated according to the procedures outlined in subdivision (e) of this rule.

(B) Probe liner. Borosilicate or quartz glass tubing with a heating system capable of maintaining a gas temperature at the exit end during sampling of  $120 \pm 14$  degrees Centigrade ( $248 \pm 25$  degrees Fahrenheit), another temperature as specified by the department's rules, or a temperature approved by the department for a particular application. The tester may opt to operate the equipment at a temperature lower than that specified. Since the actual temperature at the outlet of the probe is not usually monitored during sampling, probes constructed according to APTD-0581 which utilize the calibration curves of APTD-0576, or calibrated according to the procedure outlined in APTD-0576, are acceptable.

Either borosilicate or quartz glass probe liners may be used for stack temperatures up to about 480 degrees Centigrade (900 degrees Fahrenheit); quartz liners shall be used for temperatures between 480 and 900 degrees Centigrade (900 and 1,650 degrees Fahrenheit). Both types of liners may be used at higher temperatures than specified for short periods of time, subject to the approval of the department. The softening temperature for borosilicate is 820 degrees Centigrade (1,508 degrees Fahrenheit) and for quartz it is 1,500 degrees Centigrade (2,732 degrees Fahrenheit).

When practical, every effort shall be made to use borosilicate or quartz glass probe liners. Alternatively, metal liners, such as 316 stainless steel, Incoloy 825, or other corrosion-resistant materials made of seamless tubing, may be used, subject to the approval of the department.

(C) Pitot tube. Type S, as described in section 2.1 of method 2, or other device approved by the department. The pitot tube shall be attached to the probe, as shown in figure 103, to allow constant monitoring of the stack gas velocity. The impact (high pressure) opening plane of the pitot tube shall be even with or above the nozzle entry plane (see method 2, figure 2-6b) during sampling. The type S pitot tube assembly shall have a known coefficient, determined as outlined in section 4 of method 2.

(D) Differential pressure gauge. Incline manometer or equivalent devices (2), as described in section 2.2 of method 2. One manometer shall be used for velocity head readings, and the other shall be used for orifice differential pressure readings.

(E) Filter holders. Two separate filter holders in series or 1 filter holder with separate filter supports and seals for 2 filters. One filter holder with 2 filters held in contact with each other is not acceptable. Materials of construction may be stainless steel (316), glass, teflon, or such other material approved by the department.

(F) Filter heating system. Any heating system capable of maintaining a temperature around the filter holder during sampling of  $120 \pm 14$  degrees Centigrade ( $248 \pm 25$  degrees Fahrenheit), another

temperature as specified by the department's rules or a permit condition, or a temperature approved by the department for a particular application. Alternatively, the tester may opt to operate the equipment at a temperature lower than that specified. A temperature gauge capable of measuring temperature to within 3 degrees Centigrade (5.4 degrees Fahrenheit) shall be installed so that the temperature around the filter holders can be regulated and monitored during sampling. Heating systems other than the one shown in APTD-0581 may be used.

(G) Condenser. The following system shall be used to determine the stack gas moisture content: Three impingers connected in series with leak-free ground glass fittings or any similar leak-free noncontaminating fittings. All impingers shall be of the Greenburg-Smith design and shall be modified by replacing the tip with a 1.3 cm (1/2 in.) ID glass tube extending to about 1.3 cm (1/2 in.) from the bottom of the flask. Modifications, such as using flexible connections between the impingers or using materials other than glass, are permitted subject to the approval of the department. The first impinger shall contain a known quantity of water (subdivision (d)(i)(C) of this rule), the second shall be empty, and the third shall contain a known weight of silica gel or equivalent desiccant.

Alternatively, any system that cools the sample gas stream and allows measurement of the water condensed and moisture leaving the condenser, each to within 1 ml or 1 g, may be used subject to the approval of the department. In any case, the means for measuring the moisture leaving the condenser shall be by passing the sample gas stream through a tared silica gel, or equivalent desiccant, trap with exit gases kept below 20 degrees Centigrade (68 degrees Fahrenheit) and determining the weight gain.

If a determination of the particulate matter collected in the impingers is required by the department's rules, a permit to install, or a permit to operate, the impinger system described in this subdivision shall be used, without modification. Contact the department as to the sample recovery and analysis of the impinger contents.

(H) Metering system. Vacuum gauge, leak-free pump, thermometers capable of measuring temperature to within 3 degrees Centigrade (5.4 degrees Fahrenheit), dry-gas meter capable of measuring volume to within 2%, and related equipment as shown in figure 103. Other metering systems capable of maintaining sampling rates within 10% of isokinetic and capable of determining sample volumes to within 2% may be used, subject to the approval of the department. When the metering system is used in conjunction with a pitot tube, the system shall enable checks of isokinetic rates.

Sampling trains utilizing metering systems designed for higher flow rates than those described in APTD-0581 or APTD-0576 may be used if the specifications of this rule are met.

(I) Barometer. Mercury, aneroid, or other barometer capable of measuring atmospheric pressure to within 2.5 mm Hg (0.1 in. Hg). In many cases, the barometric reading may be obtained from a nearby national weather service station. When obtained from this source, the station value, which is the absolute barometric pressure, shall be requested and an adjustment for elevation differences between the weather station and sampling point shall be applied at a rate of minus 2.5 mm Hg (0.1 in.Hg) per 30 m (100 ft.) elevation increase or vice versa for elevation decrease.

(J) Gas density determination equipment. Temperature sensor and pressure gauge, as described in sections 2.3 and 2.4 of method 2, and gas analyzer, if necessary, as described in method 3. The temperature sensor shall, preferably, be permanently attached to the pitot tube or sampling probe in a fixed configuration such that the tip of the sensor extends beyond the leading edge of the probe sheath and does not touch any metal. Alternatively, the sensor may be attached just before use in the field. Note, however, that if the temperature sensor is attached in the field, the sensor shall be placed in an interference-free arrangement with respect to the type S pitot tube openings (see method 2, figure 2.7). As a second alternative, if a difference of not more than 1% in the average velocity measurement is to be introduced, the temperature gauge need not be attached to the probe or pitot tube. This alternative is subject to the approval of the department.

(ii) Sample recovery. The following items are needed:

(A) Probe-liner and probe-nozzle brushes. Nylon bristle brushes with stainless steel wire handles.

The probe brush shall have extensions, at least as long as the probe, made of stainless steel, nylon, teflon, or similarly inert material. The brushes shall be properly sized and shaped to brush out the probe liner and nozzle.

(B) Wash bottles--2. Glass wash bottles are recommended; polyethylene wash bottles may be used at the option of the tester. It is recommended that acetone not be stored in polyethylene bottles for longer than a month.

(C) Glass sample storage containers. Chemically resistant, borosilicate glass bottles, for acetone washes, 500 ml or 1000 ml. Screw cap liners shall either be rubber-backed teflon or shall be constructed so as to be leak-free and resistant to chemical attack by acetone. Narrow-mouth glass bottles have been found to be less prone to leakage. Alternatively, polyethylene bottles may be used.

(D) Filter containers. Glass, polyethylene, or aluminum tube containers, unless otherwise specified by the department.

(E) Graduated cylinder or balance. To measure condensed water to within 1 ml or 1 g. Graduated cylinders shall have subdivisions of not more than 2 ml. Most laboratory balances are capable of weighing to the nearest 0.5 g or less. Any of these balances are suitable for use here and in paragraph (iii)(D) of this subdivision.

(F) Plastic storage containers. Airtight containers to store silica gel.

(G) Funnel and rubber policeman. To aid in the transfer of silica gel to container; not necessary if silica gel is weighed in the field.

(H) Funnel. Glass or polyethylene, to aid in sample recovery.

(iii) Analysis. The following equipment is needed for analysis:

(A) Glass weighing dishes.

(B) Desiccator.

(C) Analytical balance. To measure to within 0.1 mg.

(D) ) Balance. To measure to within 0.5 mg.

(E) Beakers. 250 ml.

(F) Hygrometer. To measure the relative humidity of the laboratory environment.

(G) Temperature gauge. To measure the temperature of the laboratory environment.

(c) The following provisions apply to reagents:

(i) Sampling. The reagents used in sampling are as follows:

(A) Filters. Two outstack filters may be any combination of alundum ceramic thimble filters, type RA-98 or glass fiber filters, type A without organic binder. The size of such filters shall allow proper sampling rates to maintain isokinetics using the nozzle sizes specified in subdivision (b)(i)(A) of this rule.

Alternatively, other types of filters may be used, subject to the approval of the department.

(B) Silica gel. Indicating type, 6 to 16 mesh. If previously used, dry at 175 degrees Centigrade (350 degrees Fahrenheit) for 2 hours. New silica gel may be used as received. Alternatively, other types of desiccants, the equivalent or better of silica gel, may be used, subject to the approval of the department.

(C) Water. When analysis of the material caught in the impingers is required, distilled water shall be used. Run blanks before field use to eliminate a high blank on test samples.

(D) Crushed ice.

(E) Stopcock grease. Acetone-insoluble, heat-stable silicone grease. This is not necessary if screw-on connectors with teflon sleeves, or equivalent, are used. Alternatively, other types of stopcock grease may be used, subject to the approval of the department.

(ii) Sample recovery. Washing solvent. Either acetone or distilled water may be used for sample recovery. If acetone is used for washing solvent, then reagent grade, less than 0.001% residue, in glass bottles is required. Acetone from metal containers generally has a high residue blank and shall not be used. Suppliers sometimes transfer acetone to glass bottles from metal containers; thus, acetone blanks shall be run before field use, and only acetone with low blank values, less than 0.001%, shall be used. In

no case shall a blank value of more than 0.001% of the weight of acetone used be subtracted from the sample weight.

If distilled water is used for washing solvent, use distilled water with less than 0.001% residue. Run blanks before field use to eliminate a high blank on test samples.

(iii) Analysis. Two reagents are required for the analysis:

(A) Solvent. Same as paragraph (ii) of this subdivision for quantitative transfer.

(B) Desiccant. Anhydrous calcium sulfate, indicating type. Alternatively, other types of desiccants may be used, subject to the approval of the department.

(d) The following provisions apply to procedures:

(i) Determination of single measurement sites. The measurement site for a positive pressure fabric filter with an exhaust stack meeting method 1 criteria shall be in accordance with section 2.1 of method 1. The measurement site for positive pressure fabric filters with short stacks or physical configuration not amenable to the requirements of method 1 shall be determined from the following alternatives, or as approved by the department:

(A) Short stacks not meeting method 1 criteria: Short stacks may be extended in accordance with the procedures set forth in method 1 or by the use of flow straightening vanes. The flow straightening vanes shall be of the egg crate design (see figure 109). The measurement site, when using straightening vanes, shall be at a distance not less than 2 times the average equivalent diameter of the vane opening and not less than 1/2 of the overall stack diameter upstream of the stack outlet.

(B) Roof monitor or monovent exhaust outlets: For positive pressure fabric filters equipped with peaked roof monitors, ridge vents, or other types of monovalents, use a measurement site at the base of the monovent. Examples of such locations are shown in figure 108. The measurement site shall be upstream of any exhaust point.

(C) Measurement site in fabric filter compartment housing. Sample immediately downstream of the filter bags directly as shown in the examples in figure 108. Depending on the housing design, use sampling ports in the housing walls or locate the sampling equipment within the compartment housing.

(ii) Determination of number and location of traverse points. The number and location of traverse points for single exhaust stacks on positive pressure fabric filters meeting method 1 criteria shall be in accordance with section 2.3 of method 1. The number of traverse points for other single measurement sites not meeting method 1 criteria shall not be less than 24. For example, a rectangular measurement site, such as a monovent, would require the use of a balanced 5-by-5 traverse point matrix. All traverse points shall be sampled for each test run.

(iii) Multiple measurement sites. Sampling from 2 or more stacks or measurement sites may be combined for a test run, if all of the following requirements are met:

(A) All measurement sites up to 12 shall be sampled. For more than 12 measurement sites, conduct sampling on not less than 12 sites or 50% of the sites, whichever is greater. The measurement sites sampled shall be evenly, or nearly evenly, distributed among the available sites, if not all of the sites are to be sampled.

(B) The same number of measurement sites shall be sampled for each test run.

(C) The minimum number of traverse points per test run is 24. An exception to the 24-point minimum would be a test combining the sampling from 2 stacks meeting method 1 criteria for acceptable stack length, and method 1 specifies fewer than 12 points per site.

(D) As long as the 24 traverse points per test run criterion is met, the number of traverse points per measurement site may be reduced to 8.

Alternatively, conduct a test run for each measurement site individually using the criteria in this paragraph and paragraph (ii) of this subdivision for number of traverse points. Each test shall count toward the total of 3 required for a performance test. If more than 3 measurement sites are sampled, the number of traverse points per measurement site may be reduced to 8 if not less than 72 traverse points

are sampled for all 3 tests.

(iv) Sampling. The complexity of this method is such that, in order to obtain reliable results, testers shall be trained and experienced with the test procedures. Sampling shall comply with the following provisions:

(A) Pretest preparation. All the components shall be maintained and calibrated according to the applicable procedures described in APTD-0576, unless otherwise specified in this rule.

Weigh several 200 to 300 g portions of silica gel in airtight containers to the nearest 0.5 g. Record the total weight of the silica gel plus container on each container. As an alternative, the silica gel need not be preweighed, but may be weighed directly in its impinger or sampling holder just before train assembly.

Check filters visually against light for irregularities, flaws, pinhole leaks, or cracks. Label filters of the proper size on the back side using numbering machine ink. As an alternative, label the shipping containers (subdivision (b)(ii)(D) of this rule) and keep the filters in these containers at all times, except during sampling and weighing.

Dry the filters in an oven at 105 degrees Centigrade (220 degrees Fahrenheit) for a minimum of 2 hours, cool for at least 1 hour in a desiccator containing anhydrous calcium sulfate, and individually weigh and record their weights to the nearest 0.1 mg. During the weighing, the filters shall not be exposed to the laboratory atmosphere for a period of more than 2 minutes and a relative humidity above 50%. Procedures, other than those specified, that account for relative humidity effects may be used, subject to the approval of the department.

(B) Preliminary determinations. Select the sampling site and the minimum number of sampling points according to method 1 or as specified by the department. Determine the stack pressure, temperature, and the range of velocity heads using method 2; it is recommended that a leak check of the pitot lines (see method 2, section 3.1) be performed. Determine the moisture content using approximation method 4, or its alternatives, for the purpose of making isokinetic sampling rate settings. Determine the stack gas dry molecular weight, as described in method 2, section 3.6; if integrated method 3 sampling is used for molecular weight determination, the integrated bag sample shall be taken simultaneously with, and for the same total length of time as, the particulate sample run.

Select a nozzle size based on the range of velocity heads so that it is not necessary to change the nozzle size in order to maintain isokinetic sampling rates. During the run, do not change the nozzle size. Ensure that the proper differential pressure gauge is chosen for the range of velocity heads encountered (see section 2.2 of method 2).

Select a suitable probe liner and probe length so that all traverse points can be sampled. For large stacks, consider sampling from opposite sides of the stack to reduce the length of probes.

Select a total sampling time greater than or equal to the minimum total sampling time specified in the test procedures for the specific industry so that the sampling time per point is not less than 5 minutes, unless approved by the department, or some greater time interval as specified by the department, and so that the sample volume taken, corrected to standard conditions, exceeds the required minimum total gas sample volume. The latter is based on an approximate average sampling rate.

It is recommended that the number of minutes sampled at each point be an integer or an integer plus 1/2 minute to avoid timekeeping errors.

In some circumstances, such as in batch cycles, it may be necessary to sample for shorter times at the traverse points and to obtain smaller gas sample volumes. In these cases, the department's approval shall first be obtained.

(C) Preparation of collection train. During preparation and assembly of the sampling train, keep all openings where contamination can occur covered until just before assembly or until sampling is about to begin.

Place 100 ml of water in the first impinger, leave the second impinger empty, and transfer approximately 200 to 300 g of preweighed silica gel from its container to the third impinger. More silica



gel may be used, but care should be taken to ensure that it is not entrained and carried out from the impinger during sampling. Place the container in a clean place for later use in the sample recovery. Alternatively, the weight of the silica gel plus impinger may be determined to the nearest 0.5 g and recorded.

Using tweezers or clean disposable surgical gloves, place a labeled (identified) and weighed filter in the filter holder. Be sure that the filter is properly centered and the gasket properly placed so as to prevent the sample gas stream from circumventing the filter. Check the filter for tears after assembly is completed.

When glass liners are used, install the selected nozzle using a Viton A O-ring when stack temperatures are less than 260 degrees Centigrade (500 degrees Fahrenheit) and an asbestos string gasket when temperatures are higher. See APTD-0576 for details. Other connecting systems using either 310 stainless steel or teflon ferrules may be used. When metal liners are used, install the nozzle in the same manner as for glass liners or by a leak-free direct mechanical connection. Mark the probe with heat-resistant tape or by some other method to denote the proper distance into the stack or duct for each sampling point.

Set up the train as in figure 103. If necessary, use a very light coat of silicone grease on all ground glass joints. Grease only the outer portion (see APTD-0576) to avoid the possibility of contamination by the silicone grease.

Place crushed ice around the impingers.

(D) Leak check procedures:

(1) Pretest leak check. A pretest leak check is strongly recommended, but not required, to prevent invalid sampling and wasted time. If the tester opts to conduct the pretest leak check, the following procedure shall be used:

After the sampling train has been assembled, turn it on and set the filter and probe heating systems at the desired operating temperatures. Allow time for the temperatures to stabilize. If a Viton A O-ring or other leak-free connection is used in assembling the probe nozzle to the probe liner, leak check the train at the sampling site by plugging the nozzle and pulling a 380 mm Hg (15 in. Hg) vacuum. A lower vacuum may be used if it is not exceeded during the test.

If an asbestos string is used, do not connect the probe to the train during the leak check. Instead, leak check the train by first plugging the inlet to the filter holder (cyclone, if applicable) and pulling a 380 mm Hg (15 in.Hg) vacuum. A lower vacuum may be used if it is not exceeded during the test. Then connect the probe to the train and leak check at about 25 mm Hg (1 in.Hg) vacuum; alternatively, the probe may be leak checked with the rest of the sampling train, in 1 step, at 380 mm Hg (15 in. Hg) vacuum. Leakage rates in excess of 4% of the average sampling rate or 0.00057 m<sup>3</sup>/min (0.02 cfm), whichever is less, are unacceptable.

The following leak check instructions for the sampling train described in APTD-0576 and APTD-0581 may be helpful. Start the pump with the bypass valve fully open and the coarse adjust valve completely closed. Partially open the coarse adjust valve and slowly close the bypass valve until the desired vacuum is reached. Do not reverse the direction of the bypass valve; this will cause water to back up into the filter holder. If the desired vacuum is exceeded, either leak check at this higher vacuum or end the leak check and start over.

When the leak check is completed, first slowly remove the plug from the inlet to the probe, filter holder, or cyclone, if applicable, and immediately turn off the vacuum pump. This prevents the water in the impingers from being forced backward into the filter holder and prevents silica gel from being entrained backward into the third impinger.

(2) Leak checks during sample run. If, during the sampling run, a component, such as a filter assembly or impinger, change becomes necessary, a leak check shall be conducted immediately before the change is made. The leak check shall be done according to the procedure outlined in paragraph (iv)(D)(1) of this subdivision, except that it shall be done at a vacuum equal to or greater than the

maximum value recorded up to that point in the test. If the leakage rate is found to be not more than 0.00057 m<sup>3</sup>/min (0.02 cfm) or 4% of the average sampling rate, whichever is less, the results are acceptable and no correction need be applied to the total volume of dry gas metered; if, however, a higher leakage rate is obtained, the tester shall either record the leakage rate and plan to correct the sample volume, as shown in subdivision (f)(iii) of this rule, or shall void the sampling run.

Immediately after component changes, leak checks are optional; if such leak checks are done, the procedure outlined in paragraph (iv)(D)(1) of this subdivision shall be used.

(3) Post-test leak check. A leak check is mandatory at the conclusion of each sampling run. The leak check shall be done in accordance with the procedures outlined in paragraph (iv)(D)(1) of this subdivision, except that it shall be conducted at a vacuum equal to or greater than the maximum value reached during the sampling run. If the leakage rate is found to be not more than 0.00057 m<sup>3</sup>/min (0.02 cfm) or 4% of the average sampling rate, whichever is less, the results are acceptable and no correction need be applied to the total volume of dry gas metered. If, however, a higher leakage rate is obtained, the tester shall either record the leakage rate and correct the sample volume, as shown in subdivision (f)(iii) of this rule, or shall void the sampling run.

(E) Particulate train operation. During the sampling run, maintain an isokinetic sampling rate that is within 10% of true isokinetic, unless otherwise specified by the department.

For each run, record the data required on a data sheet such as the one shown in figure 104. Be sure to record the initial dry-gas meter reading. Record the dry- gas meter readings at the beginning and end of each sampling time increment, when changes in flow rates are made, before and after each leak check, and when sampling is halted. Take other readings required by figure 104 at least once at each sample point during each time increment, and take additional readings when significant changes, 20% variation in velocity head readings, necessitate additional adjustments in flow rate. Level and zero the manometer. Because the manometer level and zero may drift due to vibrations and temperature changes, make periodic checks during the traverse.

Clean the portholes before the test run to minimize the chance of sampling deposited material. To begin sampling, remove the nozzle cap and verify that the pitot tube and probe are properly positioned. Position the nozzle at the first traverse point with the tip pointing directly into the gas stream. Immediately start the pump and adjust the flow to isokinetic conditions. Nomographs that aid in the rapid adjustment of the isokinetic sampling rate without excessive computations are available. These nomographs are designed for use when the type S pitot tube coefficient is  $0.85 \pm 0.02$  and the stack gas equivalent density (dry molecular weight) is equal to  $29 \pm 4$ . APTD-0576 details the procedure for using the nomographs. If  $C_p$  and  $M_d$  are outside the above stated ranges, do not use the nomographs unless appropriate steps (see subdivision (g)(iv) of this rule) are taken to compensate for the deviations.

When the stack is under significant negative pressure (height of impinger stem), take care to pull low flow when inserting the probe into the stack to prevent water from backing into the sample tubing and to avoid pulsation through the filter and possible loss of materials.

When the probe is in position, block off the openings around the probe and porthole to prevent unrepresentative dilution of the gas stream.

Traverse the stack cross section, as required by method 1 or as specified by the department, being careful not to bump the probe nozzle into the stack walls when sampling near the walls or when removing or inserting the probe through the portholes; this minimizes the chance of extracting deposited material.

During the test run, add more ice and, if necessary, salt to maintain a temperature of less than 20 degrees Centigrade (68 degrees Fahrenheit) at the condenser/silica gel outlet. Also, periodically check the level and zero of the manometer.

If the pressure drop across the filter becomes too high and makes isokinetic sampling difficult to maintain, the filter may be replaced in the midst of a sample run. It is recommended that another complete filter assembly be used rather than attempting to change the filter itself. Before a new filter

assembly is installed, conduct a leak check (see paragraph (iv)(D)(2) of this subdivision). The total particulate weight shall include the summation of all filter assembly catches.

A single train shall be used for the entire sample run, except in cases where simultaneous sampling is required in 2 or more separate ducts, at 2 or more different locations within the same duct, or where equipment failure necessitates a change of trains. In all other situations, the use of 2 or more trains shall be subject to the approval of the department.

Note that when 2 or more trains are used, separate analyses of the front-half catches from the individual trains may be combined, as may the impinger catches, and 1 analysis of the front-half catch and 1 analysis of impinger catch may be performed. Consult with the department for details concerning the calculation of results when 2 or more trains are used.

At the end of the sample run, turn off the coarse adjust valve, remove the probe and nozzle from the stack, turn off the pump, record the final dry-gas meter reading, and conduct a post-test leak check, as outlined in paragraph (iv)(D)(3) of this subdivision. Also, leak-check the pitot lines as described in method 2, section 3.1; the lines shall pass this leak check to validate the velocity head data.

(F) Calculation of percent isokinetic. Calculate percent isokinetic (see subdivision (f) of this rule) to determine whether the run was valid or whether another test run should be made. If there was difficulty in maintaining isokinetic rates due to source conditions, consult with the department for possible variance on the isokinetic rates.

(v) Sample recovery. Proper cleanup procedure begins as soon as the probe is removed from the stack at the end of the sampling period. Allow the probe to cool.

When the probe can be safely handled, wipe off all external particulate matter near the tip of the probe nozzle and place a cap over it to prevent losing or gaining particulate matter. Do not cap off the probe tip tightly while the sampling train is cooling down as this creates a vacuum in the filter holder and draws water from the impingers into the filter holder.

Before moving the sample train to the cleanup site, remove the probe from the sample train, wipe off the silicone grease, and cap the open outlet of the probe. Be careful not to lose any condensate that might be present. Wipe off the silicone grease from the filter inlet where the probe was fastened and cap it. Remove the umbilical cord from the last impinger and cap the impinger. If a flexible line is used between the first impinger or condenser and the filter holder, disconnect the line at the filter holder and let any condensed water or liquid drain into the impingers or condenser. After wiping off the silicone grease, cap off the filter holder outlet and impinger inlet. Ground-glass stoppers, plastic caps, or serum caps may be used to close these openings.

Transfer the probe and filter-impinger assembly to the cleanup area. This area shall be clean and protected from the wind so that the chances of contaminating or losing the sample are minimized.

Save a portion of the solvent used for cleanup as a blank. Take 200 ml of this solvent directly from the wash bottle being used and place it in a glass sample container labeled "solvent blank."

Inspect the train before and during disassembly and note any abnormal conditions. Treat the samples as follows:

Container Nos. 1, 1A. Carefully remove the filters from the filter holders and place in their identified containers. Use a pair of tweezers or clean disposable surgical gloves, or both, to handle the filters. Carefully transfer to the container any particulate matter or filter fibers, or both, that adhere to the filter holder gasket by using a dry nylon bristle brush or sharp-edged blade, or both. Seal the container.

Container No. 2. Taking care to see that dust on the outside of the probe or other exterior surfaces does not get into the sample, the testor shall quantitatively recover from particulate matter or any condensate from the nozzle, probe fitting, probe liner, and from both filter holders by washing these components with solvent and placing the wash in a glass container.

Perform the solvent rinses as follows:

Carefully remove the probe nozzle and clean the inside surface by rinsing with solvent from a wash bottle and brushing with a nylon bristle brush. Brush until the solvent rinse shows no visible particles

and then make a final rinse of the inside surface with solvent.

Brush and rinse the inside parts of the Swagelok fitting with solvent in a similar way until no visible particles remain.

Rinse the probe liner with solvent by tilting and rotating the probe while squirting solvent into its upper end so that all inside surfaces are wetted with acetone. Let the solvent drain from the lower end into the sample container. A glass or polyethylene funnel may be used to aid in transferring liquid washes to the container. Follow the solvent rinse with a probe brush. Hold the probe in an inclined position and squirt solvent into the upper end as the probe brush is being pushed with a twisting action through the probe; hold a sample container underneath the lower end of the probe and catch any solvent and particulate matter that is brushed from the probe. Run the brush through the probe 3 or more times until no visible particulate matter is carried out with the solvent or until none remains in the probe liner on visual inspection. With stainless steel or other metal probes, run the brush through, in the manner set forth in this paragraph, not less than 6 times, since metal probes have small crevices in which particulate matter can be entrapped. Rinse the brush with solvent and quantitatively collect these washings in the sample container. After the brushing, make a final solvent rinse of the probe as described above.

It is recommended that 2 people be used to clean the probe to minimize sample losses. Between sampling runs, keep brushes clean and protected from contamination.

After ensuring that all joints have been wiped clean of silicone grease, clean the inside of both filter holders by rubbing the surfaces with a nylon bristle brush and rinsing with solvent. Rinse each surface 3 times, or more if needed, to remove visible particulate. Make a final rinse of the brush and filter holder.

After all solvent washings and particulate matter have been collected in the sample container, tighten the lid on the sample container so that solvent will not leak out when it is shipped to the laboratory. Mark the height of the fluid level to determine whether or not leakage occurred during transport. Label the container to clearly identify its contents.

Container No. 3. Note the color of the indicating silica gel to determine if it has been completely spent and make a notation of its condition. Transfer the silica gel from the third impinger to its original container and seal. A funnel may make it easier to pour the silica gel without spilling it. A rubber policeman may be used as an aid in removing the silica gel from the impinger. It is not necessary to remove the small amount of dust particles that adhere to the impinger wall and are difficult to remove. Since the gain in weight is to be used for moisture calculations, do not use any water or other liquids to transfer the silica gel. If a balance is available in the field, follow the procedure for container No. 3 in paragraph (vi) of this subdivision.

Impinger water. Treat the impingers as follows: Make a notation of any color or film in the liquid catch. Measure the liquid that is in the first 2 impingers to within  $\pm 1$  ml by using a graduated cylinder or by weighing it to within  $\pm 1.0$  g by using a balance if none is available. Record the volume or weight of liquid present. This information is required to calculate the moisture content of the effluent gas.

Discard the liquid after measuring and recording the volume or weight, unless analysis of the impinger catch is required (see subdivision (b)(i)(G) of this rule).

If a different type of condenser is used, measure the amount of moisture condensed either volumetrically or gravimetrically.

When possible, containers shall be shipped in a manner that keeps them upright at all times.

(vi) Analysis. Record the data required on a sheet such as the one shown in figure 106. Handle each sample container as follows:

Container Nos. 1, 1A. Analyze and report each filter separately. Transfer the filter and any loose particulate from the sample container to a tared-glass weighing dish. Dry the filter in an oven at 105 degrees Centigrade (220 degrees Fahrenheit) for a minimum of 2 hours, cool for at least 1 hour in a desiccator containing anhydrous calcium sulfate, and weigh and record its weight to the nearest 0.1 mg. During the weighing, the filter shall not be exposed to the laboratory atmosphere for a period of more than 2 minutes or a relative humidity above 50%. Procedures, other than those specified, that

account for relative humidity effects may be used, subject to the approval of the department. The method used for the drying and weighing of filters shall be consistent before and after the test.

Container No. 2. Note the level of liquid in the container and confirm on the analysis sheet whether or not leakage occurred during transport. If a noticeable amount of leakage has occurred, either void the sample or use methods, subject to the approval of the department, to correct the final results.

Measure the liquid in this container either volumetrically to  $\pm 1$  ml or gravimetrically to  $\pm 1.0$  g. Transfer the contents to a tared 250-ml beaker and evaporate to dryness either at ambient temperature and pressure for acetone or at 95 degrees Centigrade (203 degrees Fahrenheit) in an oven for distilled water. Then subject the sample to 250 degrees Centigrade (482 degrees Fahrenheit) in an oven for 2 to 3 hours. Desiccate for 24 hours and weigh to a constant weight. Report the results to the nearest 0.1 mg.

Container No. 3. Weigh the spent silica gel, or silica gel plus impinger, to the nearest 0.5 g using a balance. This step may be conducted in the field.

"Solvent blank" container. Measure solvent in this container either volumetrically or gravimetrically. Transfer the contents to a tared 250-ml beaker and evaporate to dryness either at ambient temperature and pressure for acetone or at 95 degrees Centigrade (203 degrees Fahrenheit) in an oven for distilled water. Then subject the sample to 250 degrees Centigrade (482 degrees Fahrenheit) in an oven for 2 to 3 hours. Desiccate for 24 hours and weigh to a constant weight. Report the results to the nearest 0.1 mg.

If acetone is used, the contents of container No. 2, as well as the acetone blank container, may be evaporated at temperatures higher than ambient. If evaporation is done at an elevated temperature, the temperature shall be closely supervised, and the contents of the beaker shall be swirled occasionally to maintain an even temperature. Use extreme care, as acetone is highly flammable and has a low flash point.

(e) Calibration. Maintain a laboratory log of all calibrations. The following provisions apply to calibrations:

(i) Probe nozzle. Probe nozzles shall be calibrated before their initial use in the field. Using a micrometer, measure the inside diameter of the nozzle to the nearest 0.025 mm (0.001 in.). Make 3 separate measurements using different diameters each time and obtain the average of the measurements. The difference between the high and low numbers shall not exceed 0.1 mm (0.004 in.). When nozzles become nicked, dented, or corroded, they shall be reshaped, sharpened, and recalibrated before use. Each nozzle shall be permanently and uniquely identified.

(ii) Pitot tube. The type S pitot tube assembly shall be calibrated according to the procedure outlined in section 4 of method 2.

(iii) Metering system. Before its initial use in the field, the metering system shall be calibrated according to the procedure outlined in APTD-0576. Instead of physically adjusting the dry-gas meter dial readings to correspond to the wet-test meter readings, calibration factors may be used to mathematically correct the gas meter dial readings to the proper values. Before calibrating the metering system, it is suggested that a leak check be conducted. For metering systems having diaphragm or rotary pumps, the normal leak check procedure will not detect leakages within the pump. For these cases, the following leak check procedure is suggested: Make a 10-minute calibration run at 0.00057 m<sup>3</sup>/min (0.02 cfm); at the end of the run, take the difference of the measured wet-test meter and dry-gas meter volumes; divide the difference by 10 to get the leak rate. The leak rate shall not exceed 0.00057 m<sup>3</sup>/min (0.02 cfm).

After each field use, the calibration of the metering system shall be checked by performing 3 calibration runs at a single, intermediate orifice setting, based on the previous field test, with the vacuum set at the maximum value reached during the test series. To adjust the vacuum, insert a valve between the wet-test meter and the inlet of the metering system. Calculate the average value of the calibration factor. If the calibration has changed by more than 5%, recalibrate the meter over the full range of orifice settings, as outlined in APTD-0576.

Alternatively, a spirometer may be substituted for a wet-test meter in the above mentioned

calibration procedures.

Alternative procedures, such as using the orifice meter coefficients, may be used, subject to the approval of the department.

If the dry-gas meter coefficient values obtained before and after a test series differ by more than 5%, the test series shall be performed using whichever meter coefficient value, before or after, gives the lower value of total sample volume.

(iv) Probe heater calibration. The probe heating system shall be calibrated before its initial use in the field according to the procedures outlined in APTD-0576. Probes constructed according to APTD-0581 need not be calibrated if the calibration curves in APTD-0576 are used.

(v) Temperature gauges. Use the procedure in section 4.3 of method 2 to calibrate instack temperature gauges. Dial thermometers, such as those used for the dry-gas meter and condenser outlet, shall be calibrated against mercury-in-glass thermometers.

(vi) Leak check of metering system shown in figure 103. That portion of the sampling train from the pump to the orifice meter shall be leak checked before to initial use and after each shipment. Leakage after the pump will result in less volume being recorded than is actually sampled. The following procedure is suggested (see figure 107): Close the main valve on the meter box. Insert a 1-hole rubber stopper with rubber tubing attached into the orifice exhaust pipe. Disconnect and vent the low side of the orifice manometer. Close off the low side orifice tap. Pressurize the system to 13 to 18 cm (5 to 7 in.) water column by blowing into the rubber tubing. Pinch off the tubing and observe the manometer for 1 minute. A loss of pressure on the manometer indicates a leak in the meter box; leaks, if present, shall be corrected.

(vii) Barometer. Calibrate against a mercury barometer.

(f) Calculations. When carrying out calculations, retain at least 1 extra decimal figure beyond that of the acquired data. Round off figures after the final calculation. Other forms of the equations may be used if they give equivalent results. The following provisions apply to calculations:

(i) Nomenclature:

$A_n$  = Cross-sectional area of nozzle,  $m^2$  ( $ft^2$ )

$A$  = Cross-sectional area of stack or flue at the point of sampling,  $ft.^2$ .

$B_{ws}$  = Water vapor in the gas stream, proportion by volume, expressed as a fraction.

$B_{wi}$  = Percent water vapor in gas entering source particulate control device, determined by method 4.

$B_{wo}$  = Percent water vapor in gas exiting source particulate control device.

$C_a$  = Wash blank residue concentration,  $mg/g$ .

$C_s$  = Concentration of particulate matter in stack gas, pounds per 1,000 pounds of actual stack gas.

$C_{sD}$  = Concentration of particulate matter in stack gas, moisture excluded, pounds per 1,000 pounds of dry stack gas.

$C_{s50}$  = Concentration of particulate matter corrected to 50% excess air, pounds per 1,000 pounds of stack gas.

$C_{s50D}$  = Concentration of particulate matter corrected to 50% excess air, excluding any water addition from a collector, pounds per 1,000 pounds of stack gas.

$E$  = Mass emission rate of particulate,  $lb/hr$ .

$F_{50}$  = Concentration conversion factor to 50% excess air with no moisture alterations in exhaust.

$F_{50D}$  = Concentration conversion factor to 50% excess air, excluding any moisture added to

exhaust gas by pollution collection system.

$F_D$  = Concentration conversion factor to dry basis, excluding any water in the stack gas.

$I$  = Percent of isokinetic sampling.

$L_a$  = Maximum acceptable leakage rate for either a pretest leak check or for a leak check following a component change; equal to 0.00057 m<sup>3</sup>/min (0.02 cfm) or 4% of the average sampling rate, whichever is less.

$L_i$  = Individual leakage rate observed during the leak check conducted prior to the "ith" component change ( $i = 1, 2, 3 \dots n$ ), m<sup>3</sup>/min (cfm).

$L_p$  = Leakage rate observed during the post-test leak check, m<sup>3</sup>/min (cfm).

$M_d$  = Molecular weight of dry stack gas, g/g mole (lb/lb-mole), calculated by method 3, equation 3-2, using data from integrated method 3.

$m_n$  = Total amount of particulate matter collected, mg.

$M_w$  = Molecular weight of water, 18.0 g/g-mole (18.0 lb/lb-mole).

$m_a$  = Mass of residue of solvent after evaporation, mg.

$m_g$  = Total weight of gas samples through nozzle, lb.

$P_{bar}$  = Barometric pressure at the sampling site, mm Hg (in. Hg).

$P_s$  = Absolute stack gas pressure.

$P_{std}$  = Standard absolute pressure, 760 mm Hg (29.92 in. Hg).

$R$  = Ideal gas constant, 0.06236 mm Hg-m<sup>3</sup>/°K-g-mole (21.85 in. Hg-ft<sup>3</sup>/°R-lb-mole).

$T_m$  = Absolute average dry-gas meter temperature (see figure 104), °K (°R).

$T_s$  = Absolute average stack gas temperature (see figure 104), °K (°R).

$T_{std}$  = Standard absolute temperature, 294.1 °K (530 °R).

$V_a$  = Volume of solvent blank, ml.

$V_{aw}$  = Volume of solvent used in wash, ml.

$V_{lc}$  = Total volume of liquid collected in impingers and silica gel (see figure 106), ml.

$V_m$  = Volume of gas sample as measured by dry-gas meter, dcm (dcf).

$V_{m(std)}$  = Volume of gas sample measured by the dry-gas meter, corrected to standard conditions, dscm (dscf).

$V_{w(std)}$  = Volume of water vapor in the gas sample, corrected to standard conditions, scm (scf).

$V_s$  = Stack gas velocity, calculated by method 2, equation 2-9, using data obtained from method 5, m/sec (ft./sec).

$W_a$  = Weight of residue in solvent wash, mg.

$Y$  = Dry-gas meter calibration factor.

$\Delta H$  = Average pressure differential across the orifice meter (see figure 104), mm H<sub>2</sub>O (in. H<sub>2</sub>O).

%O<sub>2</sub> = Percent oxygen in stack gas by volume (dry basis).

%N<sub>2</sub> = Percent nitrogen in stack gas by volume (dry basis).

$p_a$  = Density of solvent, mg/ml.

$p_{s(std)}$  = Density of all sampled gas at standard conditions, lb/ft.<sup>3</sup>.

$p_w$  = Density of water, 0.9982 g/ml (0.002201 lb/ml).

$\theta$  = Total sample time, min.

$\theta_1$  = Sample time, interval, from the beginning of a run until the first component change, min.

$\theta_i$  = Sampling time interval, between 2 successive component changes, beginning with the interval between the first and second changes, min.

$\theta_p$  = Sampling time interval, from the final ( $n^{\text{th}}$ ) component change until the end of the sampling run, min.

13.6 = Specific gravity of mercury.

60 = Sec/min.

100 = Conversion to percent.

386.9 = Cubic feet per lb-mole of ideal gas at standard conditions.

453.6 = Conversion of pounds to grams.

3600 = Conversion of hours to sec.

1000 = Conversion of 1000 lb units to lb units.

(ii) Average the dry-gas meter temperature and average the orifice pressure drop. See data sheet (figure 104).

(iii) Dry gas volume. Correct the sample volume measured by the dry-gas meter to standard conditions (21.1 degrees Centigrade, 760 mm Hg or 70 degrees Fahrenheit, 29.92 in. Hg) by using equation 5-1.

equation 5-1

$$V_{m(std)} = \frac{V_m Y T_{std} (P_{bar} + \Delta H/13.6)}{T_m P_{std}} = K_1 V_m Y \frac{(P_{bar} + \Delta H/13.6)}{T_m}$$

Where:

$K_1$  = 0.3869 °K/mm Hg for metric units.  
= 17.71 °R/in. Hg for English units.

Equation 5-1 can be used as written. However, if the leakage rate observed during any of the mandatory leak checks (for example, the post-test leak check or leak checks conducted before component changes) exceeds  $L_a$ , equation 5-1 shall be modified as follows:

(A) Case I. No component changes made during sampling run. In this case, replace  $V_m$  in equation 5-1 with the expression:

$$V_m - (L_p - L_a)\theta$$

(B) Case II. One or more component changes made during the sampling run. In this case, replace  $V_m$  in equation 5-1 by the expression:

$$V_m - (L_1 - L_a)\theta_1 - \sum_{i=2}^n (L_i - L_a)\theta_i - (L_p - L_a)\theta_p$$



and substitute only for those leakage rates ( $L_i$  or  $L_p$ ) that exceed  $L_a$ .

(iv) Volume of water vapor.

equation 5-2

$$V_{w(std)} = V_{1c} (P_w/M_w) (R T_{std}/P_{std}) = K_2 V_{1c}$$

Where:

$K_2 = 0.001338$  mm/ml for metric units.

$= 0.04733$  ft<sup>3</sup>/ml for English units.

(v) Moisture content.

equation 5-3

$$B_{ws} = V_{w(std)} / (V_{m(std)} + V_{w(std)})$$

In saturated or water droplet-laden gas streams, 2 calculations of the moisture content of the stack gas shall be made: 1 from the impinger analysis (equation 5-3), and a second from the assumption of saturated conditions. The lower of the 2 values of  $B_{ws}$  shall be considered correct. The procedure for determining the moisture content based upon assumption of saturated conditions is given in the note of section 1.2 of method 4. For the purpose of this method, the average stack gas temperature from figure 104 may be used to make the determination, if the accuracy of the in-stack temperature sensor is  $\pm 1$  degree Centigrade (2 degrees Fahrenheit).

(vi) Solvent blank concentration.

equation 5-4

$$C_a = m_a / (V_a P_a)$$

(vii) Solvent wash blank.

equation 5-5

$$W_a = C_a V_{aw} P_a$$

(viii) Total particulate weight. Determine the total particulate catch from the sum of the weights obtained from containers 1, 1A, and 2 less the wash solvent blank (see figure 106).

Refer to subdivision (d)(iv)(E) of this rule to assist in the calculation of results involving 2 or more pairs of filters or 2 or more sampling trains.

(ix) Sampled gas density. Determine the density of the gas sampled from the stack, at standard conditions (lb/ft.<sup>3</sup>).

equation 5-6

$$P_{s(std)} = (M_d (1 - B_{ws}) + M_w B_{ws}) / 386.9$$

(x) Total weight of gas sampled (lbs).

equation 5-7

$$m_g = (V_{m(std)} + V_{w(std)}) P_{s(std)}$$

(xi) Particulate concentration (lbs/1000 lbs).

equation 5-8

$$C_s = m_n / (453.6 m_g)$$

(xii) Excess air and moisture correction factors:

(A) Correction factor to 50% excess air for those sources with or without any particulate collector

where no increase in moisture content of the exhaust gas occurs after the process and before the point of sampling.

equation 5-9

$$F_{50} = \frac{M_d + 18 B_{wo}/(100 - B_{wo})}{0.1826 \%N_2 - 2.0592 \%O_2 + M_d + 18 B_{wo} / (100 - B_{wo})}$$

(B) Correction factor to 50% excess air for those sources with a wet collection device (scrubber) that increases the moisture content of the exhaust gas after the process and before the point of sampling.

equation 5-10

$$F_{50D} = \frac{M_d + 18 B_{wo}/(100 - B_{wo})}{0.1826 \%N_2 - 2.0592 \%O_2 + M_d + 18 B_{wi} / (100 - B_{wi})}$$

(C) Correction factor to convert the actual concentration,  $C_s$ , to dry conditions.

equation 5-11

$$F_D = \frac{M_d + 18 B_{wo}/(100 - B_{wo})}{M_d}$$

(xiii) Converted particulate concentrations, where applicable under the department's rules or permit.

equation 5-12

$$C_{s50} = C_s F_{50}$$

equation 5-13

$$C_{s50D} = C_s F_{50D}$$

equation 5-14

$$C_{s0} = C_s F_D$$

(xiv) Mass emission rate (lb/hr).

equation 5-15

$$E = \frac{3600 A V_s C_s P_s T_{std} P_{s(std)}}{1000 T_s P_{std}} = K_3 A V_s C_s P_s P_{s(std)} / T_s$$

Where:

$K_3 = 63.77$  for English units.

(xv) Velocity determinations. Velocity determinations at measurement sites with gas velocities within the range measureable with the type S pitot (for example, velocity head 1.3 mm H2O (0.05 in. H2O)) shall be conducted according to the procedures in method 2. If the velocity of exhaust gas at the measurement site is below the range measureable with the type S pitot (for example, velocity head 1.3 mm H2O) the gas velocity shall be measured at the inlet according to procedures in method 2. Calculate the average gas velocity at the measurement site as follows:

$$V_f = \frac{Q_i T_o}{A_o T_i}$$

Where:

$V_f$  = Average gas velocity of the measurement site(s), m/sec (ft./sec).

$Q_i$  = Inlet gas volume flow rate, m<sup>3</sup>/sec (ft.<sup>3</sup>/sec).

$A_o$  = Measurement site(s) total cross sectional area, m<sup>2</sup> (ft.<sup>2</sup>).

$T_o$  = Temperature of gas at measurement site, °K (°R).

$T_i$  = Temperature of gas at inlet, °K (°R).

Use the average velocity calculated for the measurement site in determining and maintaining isokinetic sampling rates.

All sources of gas leakage, into or out of the fabric filter housing between the inlet measurement site and the outlet measurement site, shall be blocked and made leaktight.

(xvi) Isokinetic variation:

(A) Calculation from raw data.

equation 5-16

$$I = \frac{100 T_s (K_4 V_{lc} + (V_m / T_m)(P_{bar} + \Delta H / 13.6))}{60 \theta V_s P_s A_n}$$

Where:

$K_4$  = 0.003458 mm Hg - m<sup>3</sup>ml - °K for metric units.

= 0.002672 in. Hg - ft.<sup>3</sup>/ml - °R for English units.

(B) Calculation from intermediate values.

equation 5-17

$$I = \frac{T_s V_{m(std)} P_{std} 100}{T_{std} V_s \theta A_n P_s 60 (1 - B_{ws})} = K_5 \frac{T_s V_{m(std)}}{P_s V_s A_n \theta (1 - B_{ws})}$$

Where:

$K_5$  = 4.307 for metric units.

= 0.09409 for English units.

(xvii) Acceptable results. If 90% ≤ I ≤ 110%, the results are acceptable. If the results are low in comparison to the standard and I is beyond the acceptable range, or if I is less than 90%, the department may opt to accept the results. Otherwise, reject the results and repeat the test.

(g) Bibliography:

(i) Federal Register, Volume 42, No. 160, Part 60, Chapter 1, Title 40, Appendix A Method 5, August 18, 1977.

(ii) Martin, Robert M. Construction Details of Isokinetic Source Sampling Equipment. Environmental Protection Agency. Research Triangle Park, N.C. APTD- 0581. April, 1971.

(iii) Rom, Jerome J. Maintenance, Calibration, and Operation of Isokinetic Source Sampling Equipment. Environmental Protection Agency. Research Triangle Park, N.C. APTD-0576. March, 1972.

(iv) Shigehara, R. T. "Adjustments in the EPA Nomograph for Different Pitot Tube Coefficients and Dry Molecular Weights." Stack Sampling News 2:4- 11. October, 1974.

(v) Guidelines for Source Testing of Particulate. Michigan Department of Natural Resources, Air Quality Division. June 1, 1977.

History: 1985 MR 2, Eff. Feb. 22, 1985; 2002 MR 5, Eff. Mar. 19, 2002. Corrected 2004 MR 18, Oct. 15, 2004.

**R 336.2021 Figures.**

Rule 1021. Figures 102 to 104 and 106 to 109 read as follows:

**FIGURE 102**

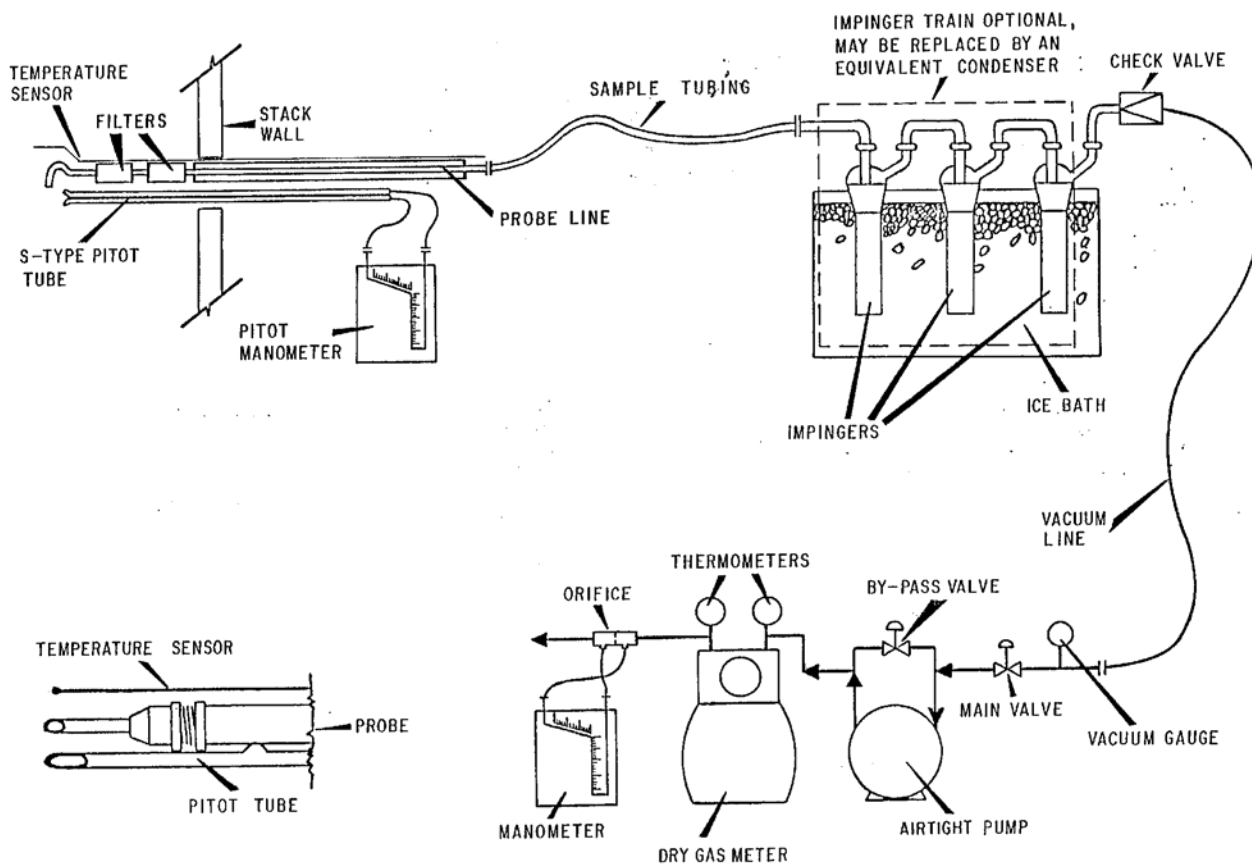

FIGURE 103  
PARTICULATE SAMPLING TRAIN

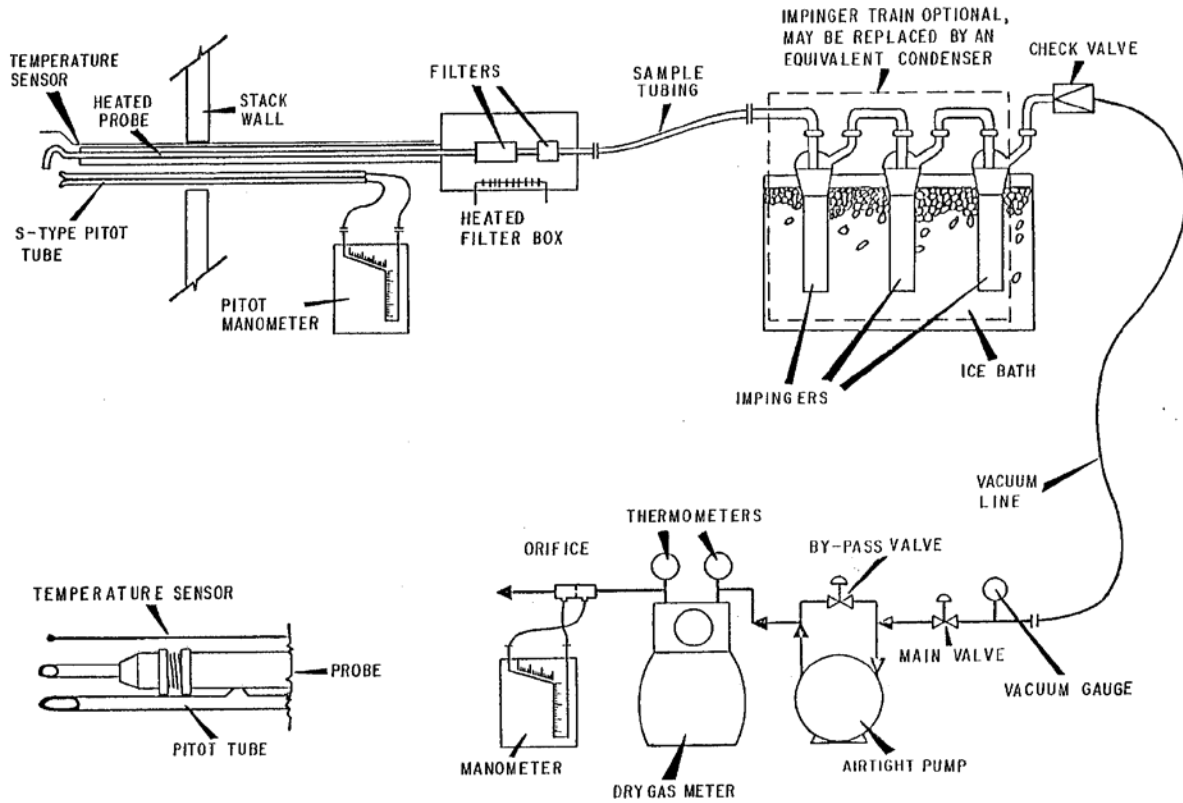

FIGURE 104. PARTICLE FIELD DATA.

PLANT \_\_\_\_\_  
 LOCATION \_\_\_\_\_  
 OPERATOR \_\_\_\_\_  
 DATE \_\_\_\_\_  
 SAMPLE BOX NO. \_\_\_\_\_  
 METER BOX NO. \_\_\_\_\_  
 METER BOX NO. \_\_\_\_\_  
 METER Δ H @ \_\_\_\_\_  
 C FACTOR \_\_\_\_\_  
 PITOT TUBE COEFFICIENT, C<sub>p</sub> \_\_\_\_\_



AMBIENT TEMPERATURE \_\_\_\_\_  
 BAROMETRIC PRESSURE \_\_\_\_\_  
 ASSUMED MOISTURE, % \_\_\_\_\_  
 PROBE LENGTH, m (ft) \_\_\_\_\_  
 NOZZLE IDENTIFICATION NO. \_\_\_\_\_  
 AVERAGE CALIBRATED NOZZLE DIAMETER, cm (in.) \_\_\_\_\_  
 PROBE HEATER SETTING \_\_\_\_\_  
 LEAK RATE, m<sup>3</sup>/min (cfm) \_\_\_\_\_  
 PROBE LINER MATERIAL \_\_\_\_\_

SCHEMATIC OF STACK CROSS SECTION

TRAVERSE POINT NUMBER	SAMPLING TIME (θ). min.	STATIC PRESSURE mm Hg (in Hg)	STACK TEMPERATURE (Ts) °C (°F)	VELOCITY HEAD (ΔPs) mm(in.)H <sub>2</sub> O	GAS SAMPLE VOLUME m <sup>3</sup> (ft <sup>3</sup> )	GAS SAMPLE TEMPERATURE		FILTER HOLDER TEMPERATURE °C(°F)	TEMPERATURE OF GAS LEAVING CONDENSER OR LAST IMPINGER °C(°F)
						INLET °C(°F)	OUTLET °C(°F)		
TOTAL						Avg.	Avg.		
AVERAGE						Avg.			

FIGURE 106. ANALYTICAL DATA.

Plant \_\_\_\_\_

Date \_\_\_\_\_

Run No. \_\_\_\_\_

Relative Humidity \_\_\_\_\_

Amount liquid lost during transport \_\_\_\_\_

Solvent blank volume, ml \_\_\_\_\_

Solvent wash volume, ml \_\_\_\_\_

Solvent blank concentration, mg/mg (equation 5-4) \_\_\_\_\_

Solvent wash blank, mg (equation 5-5) \_\_\_\_\_

CONTAINER NUMBER	WEIGHT OF PARTICULATE COLLECTED		
	FINAL WEIGHT	TARE WEIGHT	WEIGHT GAIN
1			
1A			
2			
TOTAL			
Less solvent blank			
Weight of particulate matter			

	VOLUME OF LIQUID WATER COLLECTED	
	IMPINGER VOLUME, ml	SILICA GEL WEIGHT, g
FINAL		
INITIAL		
LIQUID COLLECTED		
TOTAL VOLUME COLLECTED		g* ml

CONVERT WEIGHT OF WATER TO VOLUME BY DIVIDING TOTAL WEIGHT INCREASE BY DENSITY OF WATER (1g/ml).

$$\frac{INCREASE, g}{1 g / ml} = VOLUME WATER, ml$$

FIGURE 107  
LEAK CHECK OF METER  
BOX

BLOW INTO TUBING  
UNTIL MANOMETER  
READS 5 TO 7 INCHES  
WATER COLUMN

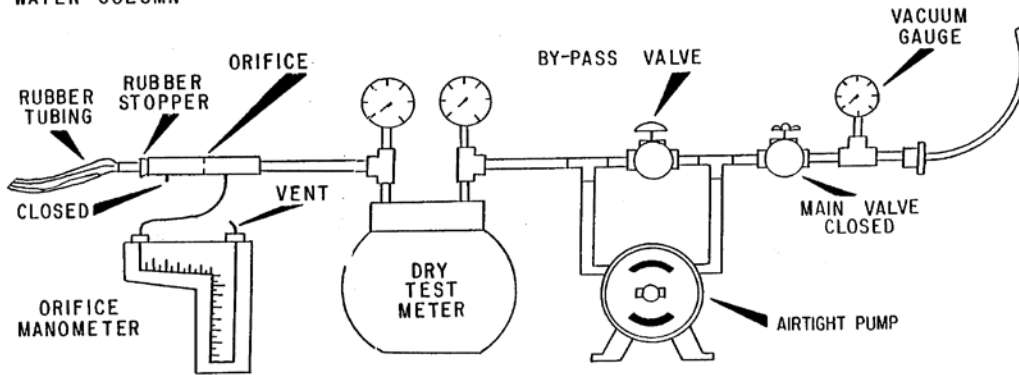



FIGURE 108  
Acceptable sampling site locations for: (a) peaked roof; and (b) ridge vent type fabric filters.

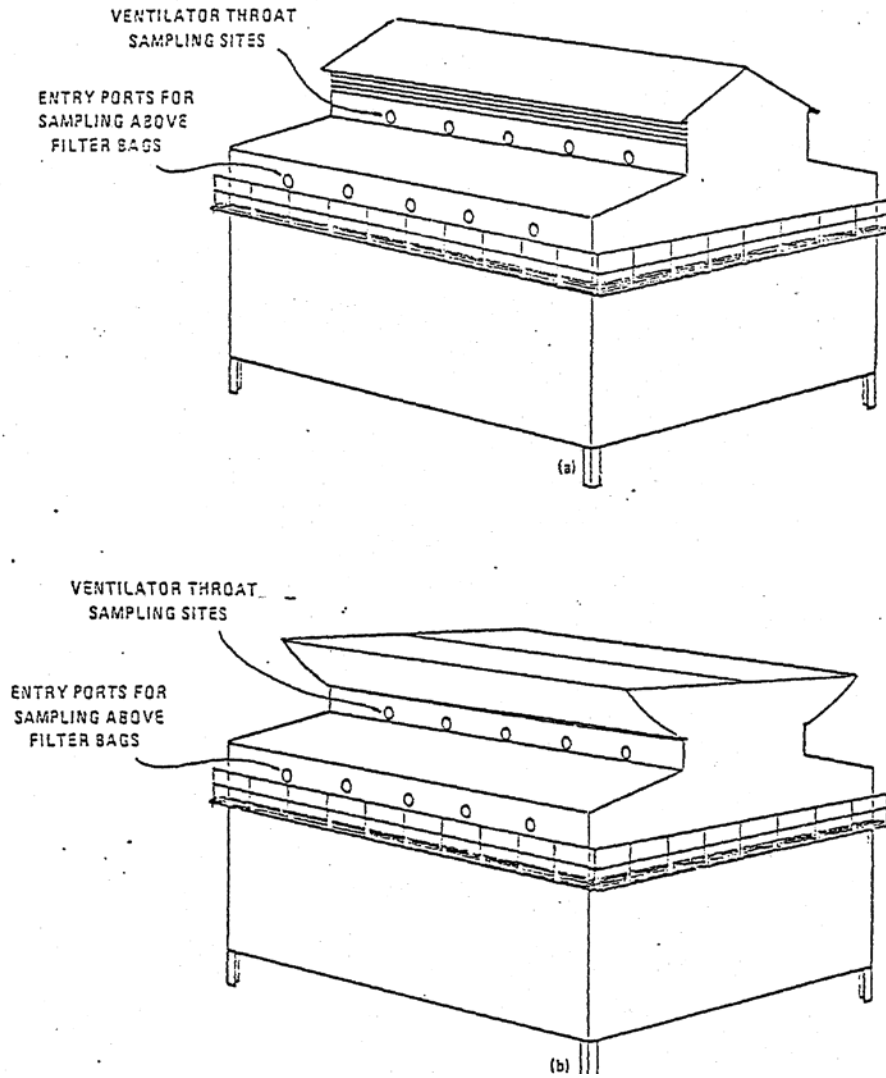
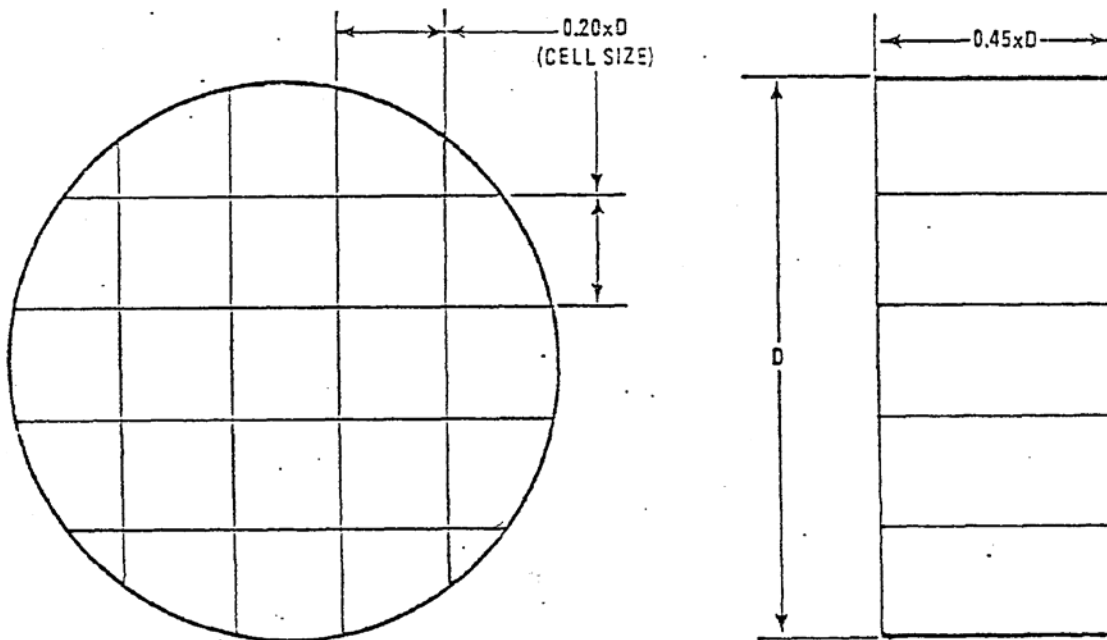

FIGURE 109  
EXAMPLE OF FLOW STRAIGHTENING  
VANES



NOTE: POSITION STRAIGHTENERS SO THAT CELL SIDES ARE LOCATED APPROX. 45° FROM TRAVERSE DIA'S.

History: 1985 MR 2, Eff. Feb. 22, 1985; 2002 MR 5, Eff. Mar. 19, 2002.

**R 336.2030 Reference test method 9A.**

Rule 1030. Reference test method 9A, opacity measurement for scarfer operations at steel manufacturing facilities, reads as follows: Visible emission evaluations for scarfer operations at steel manufacturing facilities shall be conducted as specified in reference test method 9, with the exception that the data reduction provisions of section 2.5 of method 9 shall be based on an average of 6 consecutive readings, recorded at 15-second intervals.

History: 1985 MR 2, Eff. Feb. 22, 1985

**R 336.2031 Reference test method 9B.**

Rule 1031. Reference test method 9B, coke oven inspection procedures for visible emissions, reads as follows:

(a) Charging. For the purposes of determining compliance with the coke oven standards for charging, the following inspection procedure shall be utilized:

(i) Observations for the purpose of determining compliance with the coke oven standards for

charging emissions shall be made from any point or points on the topside of a coke oven battery from which an observer can obtain an unobstructed view of the charging operation. The observer shall determine and record the total number of seconds that charging emissions are visible during the charging of coal to the coke oven. The observer shall time the visible charging emissions with a stopwatch while observing the charging period. The observer shall stop the watch when visible emissions stop or are obscured from view and shall restart the stopwatch only when visible emissions are observed again. Simultaneous emissions from more than 1 emission point shall be timed and recorded as 1 emission and shall not be added individually to the total time.

(ii) Charging emissions shall not include any emissions observed after all the charging port covers have been firmly seated following the removal of the larry car, such as emissions occurring when a cover is temporarily removed to permit the sweep-in of spilled coal.

(iii) The total number of seconds of visible emissions observed, clock time for the initiation and completion of the charging period, battery identification, and oven number of each charge shall be recorded by the observer. If observations of emissions from a charge are interrupted due to events beyond the control of the observer, the data from that charge shall be invalidated unless a violation has already been noted. The reason for invalidating the data shall be noted on the observer's observation sheet. The observer shall then resume observation of the next consecutive charge or charges, and continue until a set of consecutive charges has been obtained for comparison with the emission standard. The charge immediately preceding the interrupted charge and the charge immediately following the interrupted charge shall constitute consecutive charges. Compliance shall be determined by summing the seconds of charging emissions observed during any set of 4 consecutive charges on the same battery. Observations can be terminated once a violation has been identified, even though 4 complete charges have not been observed. Any 1 charge may be included in only 1 set of consecutive charges.

(b) Doors. Compliance with the percent door leakage standard shall be determined as follows:

(i) The area to which the door leakage standard applies is the door and any location on the perimeter of a coke oven door, including the door jamb, or, with respect to chuck doors, the door and any location on the perimeter of a chuck door, but not when emissions are seen to come from the area between a buck stay and adjacent jamb.

(ii) Observations of door emissions shall be made from a minimum distance of 25 feet from each door. Each door shall be observed in sequence for only that period necessary to determine whether or not, at the time, there are visible emissions from any point on the door while the observer walks along the side of the battery. If the observer's view of a door is more than momentarily obstructed, as, for example, by door machinery, pushing machinery, coke guide, luter truck, or opaque steam plumes, the observer shall record the door obstructed and the nature of the obstruction and continue the observations with the next door in sequence which is not obstructed. The observer shall continue this procedure along the entire length of the battery for both sides and shall record the battery identification, battery side, and oven door identification number of each door exhibiting visible emissions. Before completing the traverse, or immediately thereafter, the observer shall attempt to again observe the obstructed doors. A row of 2 or more continuous batteries may be inspected by observing all of the doors on one side of the row of batteries and then all of the doors on the other side.

(iii) Compliance with this section shall be calculated by applying the following formula separately for coke side doors, pusher side doors, and chuck doors:

$$\frac{(\text{number of doors with visible emissions on operating ovens in the battery}) \times 100}{[(\text{number of doors on total ovens in the battery}) - (\text{number of doors obstructed from view on operating ovens})]} = \text{actual percentage of doors with visible emissions}$$

(c) Ports. Compliance with the limits on visible emissions from charging ports shall be determined as follows:

(i) Observations of any visible emissions shall be made and recorded during the time an observer walks the topside of a battery from one end to the other. Each oven shall be observed in sequence.

(ii) The observer shall record the battery identification, the points of emissions from each oven, and the oven number.

(iii) The observer shall not record the following:

(A) Visible emissions from charging ports on ovens that are opened during a decarbonization period, if not more than 3 ovens are undergoing decarbonization.

(B) Visible emissions caused by maintenance work in progress at an oven.

(C) Steam emissions, including steam caused by the vaporization of wet luting materials.

(iv) Compliance shall be determined by applying the following formula:

$$\frac{(\text{number of charging ports with visible emissions on operating ovens in the battery}) \times 100}{(\text{number of charging ports on operating ovens in the battery})} = \text{actual percentage of charging ports with visible emissions}$$

(d) Standpipe assembly emission points. Compliance with the limits on visible emissions from standpipe assembly emission points shall be determined as follows:

(i) Observations of any visible emissions from the standpipe assembly shall be made by traversing the topside of the battery. During the traverse, the observer shall walk as near to the center of the battery as safety considerations permit, but may walk as close as necessary to the offtake piping to determine whether an observed emission is emanating from the standpipe assembly. If the battery has 2 collector mains, the observer may take 2 traverses to observe emissions from standpipe assembly emission points.

(ii) Each oven shall be observed in sequence.

(iii) The observer shall record the battery identification; the number of the standpipe assembly emission points with visible emissions, which shall not exceed the number of emission points on the oven; and the oven number.

(iv) The observer shall not record the following:

(A) Visible emissions from standpipe assemblies on ovens that are opened during the decarbonization period, if not more than 3 ovens are undergoing decarbonization.

(B) Visible emissions caused by maintenance work in progress at an oven.

(C) Steam emissions, including steam caused by the vaporization of wet luting material.

(v) Compliance shall be determined by applying the following formula:

$$\frac{(\text{number of standpipe assembly emission points with visible emissions on operating ovens}) \times 100}{(\text{number of standpipe assembly emission points on the operating ovens of the coke battery})} = \text{actual percentage of emission points with visible emissions}$$

(e) Pushing. Compliance with the visible emission standards during pushing operations shall be determined in accordance with the following inspection technique:

(i) Visible emission observers shall be certified in accordance with the procedures specified in reference test method 9.

(ii) Visible emissions from any pushing emission control device outlet shall be determined in accordance with the provisions of reference test method 9, except as follows:

(A) The observer shall be positioned in accordance with the provisions of section 2.1 of method 9 to the extent practicable.

(B) The data reduction provisions of section 2.5 of method 9 shall be based on an average of 6 consecutive readings taken at 15-second intervals.

(C) The readings shall commence when the coke begins to fall into the coke receiving car and shall end with the sixth reading.

(iii) In viewing fugitive push and travel emissions, the observer shall stand on the coke side of the battery where a clear view of the push can be obtained. This generally should be a location on the ground in the coke side yard outside the hot car tracks. The observer shall not be restricted to the ground level, but may make the observation from some elevated level. The observer's line of sight should be approximately perpendicular to the line of travel of the quench car. If observations of emissions from a pushing operation are interrupted due to events beyond the control of the observer, the data from that pushing operation shall be invalidated unless a violation has already been noted.

(iv) During the pushing operation, the reader shall observe all the pushing emissions, including, but not limited to, fugitive emissions from the pushing emission control device and from open quench cars during travel. All fugitive push emissions shall be read above the battery top. Fugitive emissions during travel may be read against any contrasting background.

(v) Fugitive visible emissions during the pushing of coke into the coke receiving car shall be determined in accordance with the provisions of reference test method 9, except as follows:

(A) The data reduction provisions of section 2.5 of method 9 shall be based on an average of 6 consecutive readings taken at 15-second intervals.

(B) The readings shall commence when coke begins to fall into the coke receiving car and shall end with the sixth reading.

(vi) Fugitive visible emissions during transit of the coke receiving car to the quench tower shall be determined in accordance with the provisions of reference test method 9, except as follows:

(A) The data reduction provisions of section 2.5 of method 9 shall be based on an average of as many consecutive readings as are possible during transit of the coke receiving car.

(B) The readings used to determine compliance shall be those readings taken after the car leaves the hood and until the car enters the quench tower.

(f) Definition of "operating ovens." For the purposes of subrules (2)(c), (3)(d), and (4)(e) of this rule, an "operating oven" means an oven which is not out of service for a rebuild or for maintenance that is extensive enough to require the oven to be left out of the charging sequence.

History: 1985 MR 2, Eff. Feb. 22, 1985

### **R 336.2032 Reference test method 9C.**

Rule 1032. Reference test method 9C, opacity measurement for basic oxygen furnace operations and hot metal transfer and desulfurization operations at steel manufacturing facilities, reads as follows:

Fugitive and nonfugitive visible emission evaluation for basic oxygen furnace operations, hot metal desulfurization, and hot metal transfer operations shall be conducted as specified in reference test method 9, with the exception that the data reduction provisions of section 2.5 of method 9 shall be based on an average of 12 consecutive readings recorded at 15-second intervals.

History: 1985 MR 2, Eff. Feb. 22, 1985

**R 336.2033 Test methods for coke oven quench towers.**

Rule 1033. (1) Test methods as applicable to coke oven quench towers. The publication entitled "Standard Methods for the Examination of Water and Wastewater," (14th edition), section 208C, shall apply to the measurement of total dissolved solids in coke oven quench tower water.

(2) In addition to the provisions of section 208C, all of the following provisions shall apply to the measurement of total dissolved solids in coke oven quench tower water:

(a) The quench tower makeup water shall be sampled at locations downstream of any makeup water additions.

(b) The quench tower water shall be sampled between the quench tower sump and the quench tower spray nozzles.

(c) One sample of quench tower water for all operating quench towers shall be collected once per day, 5 days per week.

(d) Compliance with the applicable quench tower limits shall be determined on a weekly basis.

(e) For purposes of determining compliance, either individual analysis of the collected samples may be averaged or a weekly composite analysis may be performed.

History: 1985 MR 2, Eff. Feb. 22, 1985

**R 336.2040 Method for determination of volatile organic compound emissions from coating lines and graphic arts lines.**

Rule 1040. (1) The methods described in this rule shall be used for the determination of volatile organic compound emissions from coating lines and graphic arts lines for the purpose of determining compliance, during the specified averaging period, with an emission limit contained in any of the following:

(a) These rules.

(b) A permit to install.

(c) A permit to operate.

(d) A voluntary agreement.

(e) A performance contract.

(f) A stipulation.

(g) An order of the department.

For emission limits expressed as pounds of volatile organic compounds per gallon of coating, minus water, as applied, the phrase "minus water" shall also include compounds which are used as organic solvents and which are excluded from the definition of volatile organic compound. Concentrations of volatile organic compounds in coatings and inks shall be determined by excluding water and compounds which are used as organic solvents and which are excluded from the definition of volatile organic compound from both the volume of volatiles in the coatings and inks and the volume of the coatings and inks as applied.

(2) Unless otherwise specified in these rules or in a legally enforceable permit, order, or contract as described in subrule (1) of this rule, for a particular coating line or graphic arts line, the applicable method for the determination of volatile organic emissions from coating lines and graphic arts lines is based upon the form of the specified emission limit as follows:

(a) For coating lines that do not have an add-on emissions control device for which emission limits are expressed in pounds of volatile organic compounds per gallon of coating, minus water, as applied, use the method described in subrule (12)(a) of this rule.

(b) For coating lines that have 1 or more add-on emissions control devices for which emission limits are expressed in pounds of volatile organic compounds per gallon of coating, minus water, as applied, use the method described in subrule (12)(b) of this rule.

(c) For coating lines that do not have an add-on emissions control device for which emission limits are expressed in pounds of volatile organic compounds per gallon of coating solids, as applied, use the method described in subrule (12)(c) of this rule.

(d) For coating lines with 1 or more add-on emissions control devices for which emission limits are expressed in pounds of volatile organic compounds per gallon of coating solids, as applied, use the method described in subrule (12)(d) of this rule.

(e) For coating lines that do not have an add-on emissions control device for which emission limits are expressed in pounds of volatile organic compounds per gallon of applied coating solids, use the method described in subrule (12)(e) of this rule.

(f) For coating lines that have 1 or more add-on emissions control devices for which emission limits are expressed in pounds of volatile organic compounds per gallon of applied coating solids, use the method described in subrule (12)(f) of this rule.

(g) For graphic arts lines that do not have an add-on emissions control device for which emission limits are expressed in pounds of volatile organic compounds per pound of solids, as applied, use the method described in subrule (12)(g) of this rule.

(h) For graphic arts lines that have 1 or more add-on emissions control devices for which emission limits are expressed in pounds of volatile organic compounds per pound of solids, as applied, use the method described in subrule (12)(h) of this rule.

(i) For flatwood paneling coating lines that do not have an add-on emissions control device for which emission limits are expressed in pounds of volatile organic compounds per 1,000 square feet of coated finished product, use the method described in subrule (12)(i) of this rule.

(j) For flatwood paneling coating lines that have 1 or more add-on emissions control devices for which emission limits are expressed in pounds of volatile organic compounds per 1,000 square feet of coated finished product, use the method described in subrule (12)(j) of this rule.

(3) The following nomenclature applies to the equations described in this rule:

(a) a = An individual duct through which gases containing volatile organic compounds are ducted to an add-on emissions control device.

(b) B = Modified emission limit, converted from pounds of volatile organic compounds per

gallon of coating, minus water, as applied, to pounds of volatile organic compounds per gallon of coating solids as applied.

(c)  $C_{im}$  = Concentration of volatile organic compounds, as measured by the applicable method, in the effluent gas flowing through stack "m" leaving the add-on emissions control device (parts per million by volume).

(d)  $C_{za}$  = Concentration of volatile organic compounds, as measured by the applicable method, in the influent gas flowing through duct "a" entering the add-on emissions control device (parts per million by volume).

(e)  $D_{ci}$  = Density of each ink or coating "i" as received from the ink or coating supplier (pounds per gallon of ink or coating).

(f)  $D_{sj}$  = Density of each volatile organic compound dilution solvent "j" added to the coating (pounds per gallon of solvent, minus water).

(g)  $DE$  = Volatile organic compound destruction efficiency of the add-on emissions control device.

(h)  $E$  = Emission limit expressed in pounds of volatile organic compounds per gallon of coating, minus water, as applied.

(i)  $G_T$  = Total volume of all coatings "z" used during the averaging period (gallons of coating, minus water, as applied).

(j)  $i$  = An individual coating used during the averaging period that belongs to the coating category for which a compliance determination is being made pursuant to the provisions of this rule. For a graphic arts line, "i" is an individual ink or coating used during the averaging period.

(k)  $j$  = An individual dilution solvent used during the averaging period that is used in conjunction with a coating "i".

(l)  $k$  = An individual method of application of coating solids.

(m)  $L_{ci}$  = Volume of each coating "i" used during the averaging period (gallons of coating, minus water, as applied).

(n)  $L_{di}$  = Volume of each ink or coating "i" as received from the ink or coating supplier and used during the averaging period (gallons of ink or coating).

(o)  $L_{ik}$  = Volume of each coating "i" used by each application method "k" during the averaging period (gallons of coating, minus water, as applied).

(p)  $L_{sj}$  = Volume of each volatile organic compound dilution solvent "j" added to the coating during the averaging period (gallons of solvent, minus water).

(q)  $M$  = Total weight of volatile organic compounds in all coatings "z" used during the averaging period for a coating line or a graphic arts line (pounds).

(r)  $m$  = An individual stack through which gases containing volatile organic compounds are ducted to the ambient air from an add-on emissions control device.

(s)  $M_r$  = Total weight of volatile organic compounds recovered from a recovery-type add-on emissions control device during the averaging period (pounds).

(t)  $N$  = Fraction, by weight, of the total volatile organic compounds emitted from an operation which is captured and enters the add-on emissions control device (pound per pound).

(u)  $NT_r$  = Fraction, by weight, of the total volatile organic compounds in all coatings "z" used during the averaging period for a coating line or a graphic arts line which is controlled by an add-on emissions control device "r" (pound per pound).

(v)  $P$  = For an individual coating "i," pounds of volatile organic compounds per gallon of coating, minus water, as applied.

(w)  $P_s$  = For an individual coating "i," pounds of volatile organic compounds, minus water,



as received from the ink or coating supplier.

(x)  $P_a$  = As used in subrule (12)(a) of this rule for coating lines that do not have an add-on emissions control device, volume-weighted average pounds of volatile organic compounds per gallon of coating, minus water, as applied, for a single coating category during the averaging period.

(y)  $P_b$  = As used in subrule (12)(b) of this rule for coating lines that have 1 or more add-on emissions control devices, volume-weighted average pounds of volatile organic compounds per gallon of coating, minus water, as applied, for a single coating category during the averaging period.

(z)  $P_c$  = As used in subrule (12)(c) of this rule for coating lines that do not have an add-on emissions control device, volume-weighted average pounds of volatile organic compounds per gallon of coating solids, as applied, for a single coating category during the averaging period.

(aa)  $P_d$  = As used in subrule (12)(d) of this rule for coating lines that have 1 or more add-on emissions control devices, volume-weighted average pounds of volatile organic compounds per gallon of coating solids, as applied, for a single coating category during the averaging period.

(bb)  $P_e$  = As used in subrule (12)(e) of this rule for coating lines that do not have an add-on emissions control device, volume-weighted average pounds of volatile organic compounds per gallon of applied coating solids for a single coating category during the averaging period.

(cc)  $P_f$  = As used in subrule (12)(f) of this rule for coating lines that have 1 or more add-on emissions control devices, volume-weighted average pounds of volatile organic compounds per gallon of applied coating solids for a single coating category during the averaging period.

(dd)  $P_g$  = As used in subrule (12)(g) of this rule for graphic arts lines that do not have an add-on emissions control device, average pounds of volatile organic compounds per pound of solids, as applied, for all inks and coatings used during the averaging period.

(ee)  $P_h$  = As used in subrule (12)(h) of this rule for graphic arts lines that have 1 or more add-on emissions control devices, average pounds of volatile organic compounds per pound of solids, as applied, for all inks and coatings used during the averaging period.

(ff)  $P_i$  = As used in subrule (12)(i) of this rule for flatwood paneling coating lines that do not have an add-on emissions control devices, volume-weighted average pounds of volatile organic compounds per 1,000 square feet of coated finished product for a single-coating category during the averaging period.

(gg)  $P_j$  = As used in subrule (12)(j) of this rule for flatwood paneling coating lines that have 1 or more add-on emissions control devices, volume-weighted average pounds of volatile organic compounds per 1,000 square feet of coated finished product for a single-coating category during the averaging period.

(hh)  $Q_{im}$  = Volumetric flow rate of the effluent gas flowing through stack "m" leaving the add-on emissions control device (dry standard cubic feet per hour).

(ii)  $Q_{za}$  = Volumetric flow rate of the influent gas flowing through duct "a" entering the add-on emissions control device (dry standard cubic feet per hour).

(jj)  $Q_{3n}$  = Volumetric flow rate of the effluent gas leaving an uncontrolled stack "n" (dry standard cubic feet per hour).

(kk)  $r$  = An individual add-on emissions control device.

(ll)  $R_r$  = Reduction efficiency of a single add-on emissions control device.

(mm)  $R_t$  = Overall reduction efficiency of all add-on emissions control devices used for a coating line or a graphic arts line.

(nn)  $s$  = The total number of different add-on control devices "r" on a coating line or graphic

arts line.

(oo)  $S_q$  = The total surface area of coated finished product for a single-coating category for a flatwood paneling coating line during the averaging period (square feet).

(pp)  $T$  = Overall transfer efficiency for all coatings "i" for a single-coating category on a coating line for the averaging period.

(qq)  $t$  = The total number of stacks "m" leaving an add-on emissions control device "r".

(rr)  $T_i$  = Transfer efficiency for application of coating "i" (%).

(ss)  $u$  = Total number of ducts "a" entering an add-on emissions control device "r".

(tt)  $U_{ci}$  = For representative colors and parts that are tested for transfer efficiency, " $U_{ci}$ " is the volume of each representative color of coating that is applied to each representative part on a coating line during the averaging period.

(uu)  $V$  = For a coating line, the volume of solids in all coatings used "zc" during the averaging period (gallons).

(vv)  $V_{ci}$  = Proportion of solids by volume in each coating "i" (gallon of solids per gallon of coating, minus water, as applied).

(ww)  $W$  = For a graphic arts line, the weight of solids in all inks and coatings used "zg" during the averaging period (pounds).

(xx)  $W_{ci}$  = Proportion of volatiles (volatile organic compounds, water, and exempt compounds) by weight in each ink or coating "i" as received from the ink or coating supplier (pound of volatiles per pound of coating).

(yy)  $x$  = The total number of different application methods "k."

(zz)  $y$  = The total number of different dilution solvents "j."

(aaa)  $z$  = The total number of different coatings "i" used on a coating line or different number of inks and coatings "i" used on a graphic arts line during the averaging period. "z" is used generically in the equations specified in this rule for "zc" when the calculation is made for a coating line and for "zg" when the calculation is made for a graphic arts line.

(bbb)  $zc$  = The total number of different coatings "i" in the same coating category used during the averaging period.

(ccc)  $zg$  = The total number of different inks and coatings "i" used during the averaging period.

(4) The following provisions apply to the calculations for a coating line or graphic arts line made pursuant to the methods described in this rule:

(a) When carrying out calculations, carry not less than 5 significant digits in intermediate calculations. Round off figures after the final calculation, rounding off calculated emission numbers to not less than 2, but not more than 3, significant figures.

(b) The calculations for a coating line shall include all of the coatings which are in the same coating category and which are used during the averaging period as specified in the applicable emission limit.

(c) Except as specified in R 336.1624(5)(d), the calculations for a graphic arts line shall include all of the inks and coatings that are used during the averaging period as specified in the applicable emission limit.

(5) The volatile organic compound content of an ink or coating, minus water, as applied, "P," shall be determined using any of the following methods:

(a) The volatile organic compound content of an ink or coating, minus water, as applied, "P," shall be determined according to all of the following provisions:

(i) The volatile organic compound content, minus water, as applied, shall be determined as

follows:

(A) For a coating used on a coating line or a coating used on a graphic arts line, the volatile organic compound content, minus water, as applied, shall be determined using federal reference method 24 or federal reference method 24a, as applicable to the coating, as described in R 336.2004, or an alternate method approved by the department.

(B) For an ink that is used on a graphic arts line, the volatile organic compound content, minus water, as applied, shall be determined using federal reference method 24a, as described in R 336.2004.

(ii) The ink or coating sample shall be taken at a point where the sample will be representative of the ink or coating material as applied.

(iii) The sample shall be stored in an enclosed container that is not less than 1 pint in volume.

(iv) By using a procedure that is acceptable to the department, the amount of any compound in the sample that is excluded from the definition of volatile organic compound may be quantified and subtracted from the total amount of volatiles in the sample as determined by federal reference method 24, federal reference method 24a, or an alternate method that is approved by the department. In this case, the volume of any excluded compound in the sample shall also be subtracted from the volume of the ink or coating sample.

(b) Upon written approval by the department, the volatile organic compound content of an ink or coating may be determined from formulation data, which includes batch composition information from the ink or coating manufacturer and the amount of volatile organic compound dilution solvent added to the ink or coating before application. In this case, "P" shall be calculated using the following equation:

$$P = \frac{L_{di} P_s + L_{sj} D_{sj}}{L_{di} + L_{sj}}$$

(c) If a coating or ink is tested by a federal reference method 24 or 24a analysis or by an alternate method approved by the department and the results are different than calculated through formulation data review, then the test method results shall be used for determining compliance with the emission limit.

(6) The weight of volatile organic compounds that are used during the averaging period shall be calculated using the following equation, where "z" is the total number of coatings used:

$$M = \sum_{i=1}^z L_{ci} P$$

(7) The total volume of coating solids that are used during the averaging period shall be calculated using the following equation, where "z" is the total number of coatings used:

$$V = \sum_{i=1}^z L_{ci} V_{ci}$$

(8) The total weight of ink and coating solids that are used during the averaging period shall be calculated using the following equation, where "zg" is the total number of inks and coatings used during the averaging period:

$$W = \sum_{i=1}^{zg} L_{di} D_{ci} (1 - W_{ci})$$

(11) The overall reduction efficiency of add-on emissions control devices shall be determined using 1 or more of the following methods, as applicable:

(a) When a destructive-type add-on emissions control device is used, the reduction efficiency for the add-on emissions control device shall be determined by using the following method:

(i) The destruction efficiency of the add-on emissions control device is calculated by using the following equation, where "u" is the total number of ducts entering the control device and "t" is the total number of stacks leaving the control device:

$$DE = \frac{\sum_{a=1}^u Q_{za} C_{za} - \sum_{n=1}^t Q_{im} C_{im}}{\sum_{a=1}^u Q_{za} C_{za}}$$

(ii) Using the destruction efficiency as determined in paragraph (i) of this subdivision, the reduction efficiency of the add-on emissions control device is calculated by using the following equation:

$$R_r = (DE)N$$

(iii) If there is only 1 add-on emissions control device used on a coating line or graphic arts line, use the value calculated for "Rr" pursuant to paragraph (ii) of this subdivision as the value for RT in subsequent calculations.

(iv) The concentration of volatile organic compound emissions entering and exiting the add-on emissions control device shall be determined by using federal reference methods 25 or 25a, federal reference method 18 if approved by the department, the alternate version of federal reference method 25 incorporating the Byron analysis, or an alternate method that is acceptable to the department. Federal reference methods 1, 2, 3, and 4 shall be used for the determination of the volumetric flow rate in the effluent gas. Alternate federal reference method 1A, 2A, 2C, or 2D shall be used where appropriate.

(b) When an add-on emissions control device is used that recovers volatile organic compounds, the reduction efficiency of the device shall be determined by using 1 of the following methods:

(i) A mass balance of the products used and the products recovered, using the following equation:

$$R_r = \frac{M_r}{M}$$

(ii) An alternate method that is acceptable to the department.

(iii) If there is only 1 add-on emissions control device used on a coating line or a graphic arts line, use the value calculated for "Rr" pursuant to paragraph (i) or (ii) of this subdivision as the value for R<sub>T</sub> in subsequent calculations.

(c) If there is more than 1 add-on emissions control device used on a coating line or a graphic arts line, calculate the overall reduction efficiency by using the following equation:

$$R_T = \sum_{r=1}^s R_r (NT_r)$$

(12) Compliance with the specified emission limit shall be determined using 1 of the following methods, as applicable, based upon the form of the emission limit:

(a) For coating lines that do not have an add-on emissions control device for which emission limits are expressed in pounds of volatile organic compounds per gallon of coating, minus water, as applied, use either of the following methods:

(i) If only 1 coating is used on the coating line during the averaging time, use the following method:

(A) Determine the volatile organic compound content of the coating, minus water, as applied, "P," by using the method described in subrule (5) of this rule.

(B) If "P" is less than or equal to the specified emission limit, the coating line meets the emission limit.

(ii) If more than 1 coating of the same coating category is used on the coating line during the averaging period, use the following method:

(A) Determine the volatile organic compound content of each coating, minus water, as applied, that belongs to the same coating category "P" used during the averaging period by using the method described in subrule (5) of this rule.

(B) Determine the weight of volatile organic compounds used during the averaging period "M" by using the method described in subrule (6) of this rule.

(C) Determine the total volume of coatings used on the coating line during the averaging period "G<sub>T</sub>" using the following equation:

$$G_T = \sum_{i=1}^z L_{ci}$$

(D) Determine the volume-weighted average weight of volatile organic compounds per gallon, minus water, as applied, by using the following equation:

$$P_a = \frac{M}{G_T}$$

(E) If "P<sub>a</sub>" is less than or equal to the specified emission limit, the coating line meets the emission limit.

(b) For coating lines that have 1 or more add-on emissions control devices for which emission limits are expressed in pounds of volatile organic compounds per gallon of coating, minus water, as applied, use the following method:

(i) Convert the specified emission limit to a modified emission limit "B" expressed in pounds of volatile organic compounds per gallon of coating solids, as applied, by using the following equation:

$$B = \frac{E}{1 - \frac{E}{7.36}}$$

(ii) Determine the volatile organic compound content of each coating, minus water, as applied, that belongs to the same coating category "P" used during the averaging period by using the method described in subrule (5) of this rule.

(iii) Determine the weight of volatile organic compounds used during the averaging period "M" by using the method described in subrule (6) of this rule.

(iv) Determine the total volume of coating solids used during the averaging period "V" by using the method described in subrule (7) of this rule.

(v) Determine the overall capture efficiency "N" by using the method described in subrule (10) of this rule.

(vi) Determine the overall reduction efficiency "R<sub>T</sub>" by using the method described in subrule (11) of this rule.

(vii) Determine the volume-weighted average weight of volatile organic compounds per gallon of coating solids, as applied, "P<sub>b</sub>," by using the following equation:

$$P_b = \frac{M}{V} (1 - R_T)$$

(viii) If "P<sub>b</sub>" is less than or equal to the modified limit "B," the coating line meets the emission limit.

(c) For coating lines that do not have an add-on emissions control device for which emission limits are expressed in pounds of volatile organic compounds per gallon of coating solids, as applied, use the following method:

(i) Determine the volatile organic compound content of each coating, minus water, as applied, that belongs to the same coating category "P" used during the averaging period by using the method described in subrule (5) of this rule.

(ii) Determine the weight of volatile organic compounds used during the averaging period "M" by using the method described in subrule (6) of this rule.

(iii) Determine the total volume of coating solids used during the averaging period "V" by using the method described in subrule (7) of this rule.

(iv) Determine the volume-weighted average weight of volatile organic compounds per gallon of coating solids, as applied, "P<sub>c</sub>," by using the following equation:

$$P_c = \frac{M}{V}$$

(v) If "P<sub>c</sub>" is less than or equal to the specified limit, the coating line meets the emission limit.

(d) For coating lines that have 1 or more add-on emissions control devices for which emission limits are expressed in pounds of volatile organic compounds per gallon of coating solids, as applied, use the following method:

(i) Determine the volatile organic compound content of each coating, minus water, as applied, that belongs to the same coating category "P" used during the averaging period by using the method described in subrule (5) of this rule.

(ii) Determine the weight of volatile organic compounds used during the averaging period "M" by using the method described in subrule (6) of this rule.

(iii) Determine the total volume of coating solids used during the averaging period "V" by using the method described in subrule (7) of this rule.

(iv) Determine the overall capture efficiency "N" by using the method described in subrule (10) of this rule.

(v) Determine the overall reduction efficiency "R<sub>T</sub>" by using the method described in subrule (11) of this rule.

(vi) Determine the volume-weighted average weight of volatile organic compounds per gallon of coating solids, as applied, "P<sub>d</sub>," by using the following equation:

$$P_d = \frac{M}{V}(1 - R_T)$$

(vii) If "P<sub>d</sub>" is less than or equal to the specified limit, the coating line meets the emission limit.

(e) For coating lines that do not have an add-on emissions control device for which emission limits are expressed in pounds of volatile organic compounds per gallon of applied coating solids, use the following method:

(i) Determine the volatile organic compound content of each coating, minus water, as applied, that belongs to the same coating category "P" used during the averaging period by using the method described in subrule (5) of this rule.

(ii) Determine the weight of volatile organic compounds used during the averaging period "M" by using the method described in subrule (6) of this rule.

(iii) Determine the total volume of coating solids used during the averaging period "V" by using the method described in subrule (7) of this rule.

(iv) Determine the overall transfer efficiency "T" by using the method described in subrule (9) of this rule.

(v) Determine the volume-weighted average weight of volatile organic compounds per gallon of applied coating solids "P<sub>e</sub>" by using the following equation:

$$P_e = \frac{M}{V \frac{(T)}{100}}$$

(vi) If "P<sub>e</sub>" is less than or equal to the specified limit, the coating line meets the emission limit.

(f) For coating lines that have 1 or more add-on emissions control devices for which emission limits are expressed in pounds of volatile organic compounds per gallon of applied coating solids, use the following method:

(i) Determine the volatile organic compound content of each coating, minus water, as applied, that belongs to the same coating category "P" used during the averaging period by using the method described in subrule (5) of this rule.

(ii) Determine the weight of volatile organic compounds used during the averaging period "M" by using the method described in subrule (6) of this rule.

(iii) Determine the total volume of coating solids used during the averaging period "V" by using the method described in subrule (7) of this rule.

(iv) Determine the overall transfer efficiency "T" by using the method described in subrule (9) of this rule.

(v) Determine the overall capture efficiency "N" by using the method described in subrule (10) of this rule.

(vi) Determine the overall reduction efficiency "R<sub>T</sub>" by using the method described in subrule (11) of this rule.

(vii) Determine the volume-weighted average weight of volatile organic compounds per gallon of applied coating solids "P<sub>f</sub>" by using the following equation:

$$P_f = \frac{M}{V \frac{(T)}{100}} (1 - R_T)$$

(viii) If "P<sub>f</sub>" is less than or equal to the specified limit, the coating line meets the emission limit.

(g) For graphic arts lines that do not have an add-on emissions control device for which emission limits are expressed in pounds of volatile organic compounds per pound of solids, as applied, use the following method:

(i) Determine the volatile organic compound content of each ink and coating, minus water, as applied, "P," used during the averaging period by using the method described in subrule (5) of this rule.

(ii) Determine the weight of volatile organic compounds used during the averaging period "M" by using the method described in subrule (6) of this rule.

(iii) Determine the weight of ink and coating solids used during the averaging period "W" by using the method described in subrule (8) of this rule.

(iv) Determine the average pounds of volatile organic compound per pound of solids, as applied, "P<sub>g</sub>," by using the following equation:

$$P_g = \frac{M}{W}$$

(v) If "P<sub>g</sub>" is less than or equal to the specified limit, the graphic arts line meets the emission limit.

(h) For graphic arts lines that have 1 or more add-on emissions control devices for which emission limits are expressed in pounds of volatile organic compounds per pound of solids, as applied, use the following method:

(i) Determine the volatile organic compound content of each ink and coating, minus water, as applied, "P," used during the averaging period by using the method described in subrule (5) of this rule.

(ii) Determine the weight of volatile organic compounds used during the averaging period "M" by using the method described in subrule (6) of this rule.

(iii) Determine the weight of ink and coating solids used during the averaging period "W" by using the method described in subrule (8) of this rule.

(iv) Determine the overall capture efficiency "N" by using the method described in subrule (10) of this rule.

(v) Determine the overall reduction efficiency "R<sub>t</sub>" by using the method described in subrule (11) of this rule.

(vi) Determine the average pounds of volatile organic compound per pound of solids, as applied, "P<sub>h</sub>," by using the following equation:

$$P_h = \frac{M}{W} (1 - R_T)$$

(vii) If "P<sub>h</sub>" is less than or equal to the specified limit, the graphic arts line meets the emission limit.

(i) For flatwood paneling coating lines that do not have an add-on emissions control device for which emission limits are expressed in pounds of volatile organic compound per 1,000 square feet of coated finished product, use the following method:



(i) Determine the volatile organic compound content of each coating, minus water, as applied that belongs to the same coating category "P" used during the averaging period by using the method described in subrule (5) of this rule.

(ii) Determine the weight of volatile organic compounds used during the averaging period "M" by using the method described in subrule (6) of this rule.

(iii) Determine the total surface area of coated finished product for the coating category during the averaging period "sq".

(iv) Determine the volume-weighted average pounds of volatile organic compounds per 1,000 square feet of coated finished product "P<sub>i</sub>" by using the following equation:

$$P_i = \frac{\frac{M}{sq}}{1,000}$$

Where the units for the term 1,000 are square feet.

(v) If "P<sub>i</sub>" is less than or equal to the specified limit, the coating line meets the emission limit.

(j) For flatwood paneling coating lines that have 1 or more add-on emissions control devices for which emission limits are expressed in pounds of volatile organic compounds per 1,000 square feet of coated finished product, use the following method:

(i) Determine the volatile organic compound content of each coating, minus water, as applied, that belongs to the same coating category "P" used during the averaging period by using the method described in subrule (5) of this rule.

(ii) Determine the weight of volatile organic compounds used during the specified averaging period "M" by using the method described in subrule (6) of this rule.

(iii) Determine the total surface area of coated finished product for the coating category during the averaging period "sq".

(iv) Determine the overall capture efficiency "N" by using the method described in subrule (10) of this rule.

(v) Determine the overall reduction efficiency "RT" by using the method described in subrule (11) of this rule.

(vi) Determine the volume-weighted average pounds of volatile organic compounds per 1,000 square feet of coated finished product "P<sub>j</sub>" by using the following equation:

$$P_j = \frac{\frac{M}{sq}}{1,000} (1 - R_T)$$

Where the units for the term 1,000 are square feet.

(vii) If "P<sub>j</sub>" is less than or equal to the specified limit, the coating line meets the emission limit.

History: 1993 AACCS; 2002 MR 5, Eff. Mar. 19, 2002.

### **R 336.2041 Recordkeeping requirements for coating lines and graphic arts lines.**

Rule 1041. (1) The recordkeeping requirements specified in this rule shall apply to coating lines and graphic arts lines subject to emission limits contained in any of the following:

(a) These rules.

(b) A permit to install.

- (c) A permit to operate.
- (d) A voluntary agreement.
- (e) A performance contract.
- (f) A stipulation.
- (g) An order of the commission.

(2) For coating lines that do not have an add-on emissions control device for which emission limits are expressed in pounds of volatile organic compounds per gallon of coating, minus water, as applied, and only 1 coating is used on the coating line during the averaging time, a person shall keep records of the name, identification number, volume "L<sub>ci</sub>" and volatile organic compound content of the coating, minus water, as applied, "P," used during the averaging period, as described in R 336.2040(5). If this single coating used during an averaging period is in compliance with all of the emission limits specified in subrule (1) of this rule, the volume "L<sub>ci</sub>" for the averaging period may be calculated, based upon coating usage records during a time period of not more than 1 month, with the coating usage prorated to the specified averaging period using a method approved by the commission for that coating line.

(3) For coating lines that do not have an add-on emissions control device for which emission limits are expressed in pounds of volatile organic compounds per gallon of coating, minus water, as applied, and if more than 1 coating of the same coating category is used on the coating line during the averaging period, a person shall keep the following records:

(a) The name, identification number, volume "L<sub>ci</sub>" and volatile organic compound content of each coating, minus water, as applied, that belongs to the same coating category "P" used during the averaging period, as described in R 336.2040(5). If all coatings used on the coating line during an averaging period are in compliance with all of the emission limits specified in subrule (1) of this rule, the volume "L<sub>ci</sub>" for the averaging period may be calculated, based upon coating usage records during a time period of not more than 1 month, with the coating usage prorated to the specified averaging period using a method approved by the commission for that coating line.

(b) The weight of volatile organic compounds used during the averaging period "M," as described in R 336.2040(6).

(c) The total volume of coatings used on the coating line during the averaging period "G<sub>T</sub>," as described in R 336.2040(12).

(d) The volume-weighted average weight of volatile organic compounds per gallon, minus water, as applied, "P<sub>a</sub>," as described in R 336.2040(12).

(4) For coating lines that have 1 or more add-on emissions control devices for which emission limits are expressed in pounds of volatile organic compounds per gallon of coating, minus water, as applied, a person shall keep the following records:

(a) The name, identification number, volume "L<sub>ci</sub>" and volatile organic compound content of each coating, minus water, as applied, that belongs to the same coating category "P" used during the averaging period, as described in R 336.2040(5).

(b) The weight of volatile organic compounds used during the averaging period "M," as described in R 336.2040(6).

(c) The total volume of coating solids and volume of ink or coating "L<sub>di</sub>" used during the averaging period "V," as described in R 336.2040(7).

(d) The overall capture efficiency "N," as described in R 336.2040(10).

(e) The overall reduction efficiency "R<sub>i</sub>" as described in R 336.2040(11), including the parameters "O<sub>za</sub>," "C<sub>za</sub>," "Q<sub>im</sub>," "C<sub>im</sub>," and "M<sub>T</sub>."

(f) The volume-weighted average weight of volatile organic compounds per gallon of coating

solids, as applied, "P<sub>b</sub>," as described in R 336.2040(12).

(5) For coating lines that do not have an add-on emissions control device for which emission limits are expressed in pounds of volatile organic compounds per gallon of coating solids, as applied, a person shall keep the following records:

(a) The name, identification number, volume "L<sub>ci</sub>" and volatile organic compound content of each coating, minus water, as applied, that belongs to the same coating category "P" used during the averaging period, as described in R 336.2040(5).

(b) The weight of volatile organic compounds used during the averaging period "M," as described in R 336.2040(6).

(c) The total volume of coating solids and volume of ink or coating "L<sub>di</sub>" used during the averaging period "V," as described in R 336.2040(7).

(d) The volume-weighted average weight of volatile organic compounds per gallon of coating solids, as applied, "P<sub>c</sub>," as described in R 336.2040(12).

(6) For coating lines that have 1 or more add-on emissions control devices for which emission limits are expressed in pounds of volatile organic compounds per gallon of coating solids, as applied, a person shall keep the following records:

(a) The name, identification number, volume "L<sub>ci</sub>" and volatile organic compound content of each coating, minus water, as applied, that belongs to the same coating category "P" used during the averaging period, as described in R 336.2040(5).

(b) The weight of volatile organic compounds used during the averaging period "M," as described in R 336.2040(6).

(c) The total volume of coating solids and volume of ink or coating "L<sub>di</sub>" used during the averaging period "V," as described in R 336.2040(7).

(d) The overall capture efficiency "N," as described in R 336.2040(10).

(e) The overall reduction efficiency "R<sub>t</sub>," as described in R 336.2040(11), including the parameters "Q<sub>za</sub>," "C<sub>za</sub>," "Q<sub>im</sub>," "C<sub>im</sub>," and "M<sub>r</sub>."

(f) The volume-weighted average weight of volatile organic compounds per gallon of coating solids, as applied, "P<sub>d</sub>," as described in R 336.2040(12).

(7) For coating lines that do not have an add-on emissions control device for which emission limits are expressed in pounds of volatile organic compounds per gallon of applied coating solids, a person shall keep the following records:

(a) The name, identification number, volume "L<sub>ci</sub>" and volatile organic compound content of each coating, minus water, as applied, that belongs to the same coating category "p" used during the averaging period, as described in R 336.2040(5).

(b) The weight of volatile organic compounds used during the averaging period "M," as described in R 336.2040(6).

(c) The total volume of coating solids and volume of ink or coating "L<sub>di</sub>" used during the averaging period "V," as described in R 336.2040(7).

(d) The overall transfer efficiency "T," as described in R 336.2040(9), including "T<sub>i</sub>" and "U<sub>ci</sub>".

(e) The volume-weighted average weight of volatile organic compounds per gallon of applied coating solids "P<sub>e</sub>," as described in R 336.2040(12).

(8) For coating lines that have 1 or more add-on emissions control devices for which emission limits are expressed in pounds of volatile organic compounds per gallon of applied coating solids, a person shall keep the following records:

(a) The name, identification number, volume "L<sub>ci</sub>" and volatile organic compound content of

each coating, minus water, as applied, that belongs to the same coating category "P" used during the averaging period, as described in R 336.2040(5).

(b) The weight of volatile organic compounds used during the averaging period "M," as described in R 336.2040(6).

(c) The total volume of coating solids and volume of ink or coating "L<sub>di</sub>" used during the averaging period "V," as described in R 336.2040(7).

(d) The overall transfer efficiency "T," as described in R 336.2040(9), including "T<sub>i</sub>" and "U<sub>ci</sub>".

(e) The overall capture efficiency "N," as described in R 336.2040(10).

(f) The overall reduction efficiency "R<sub>t</sub>," as described in R 336.2040(11), including the parameters "Q<sub>za</sub>," "C<sub>za</sub>," "Q<sub>im</sub>," "V<sub>im</sub>," and "M."

(g) The volume-weighted average weight of volatile organic compounds per gallon of applied coating solids "P<sub>f</sub>," as described in R 336.2040(12).

(9) For graphic arts lines that do not have an add-on emissions control device for which emission limits are expressed in pounds of volatile organic compounds per pound of solids, a person shall keep the following records:

(a) The name, identification number, volume "L<sub>ci</sub>" and volatile organic compound content of each ink and coating, minus water, as applied, "P," used during the averaging period, as described in R 336.2040(5).

(b) The weight of volatile organic compounds used during the averaging period "M," as described in R 336.2040(6).

(c) The weight of ink and coating solids used during the averaging period "W," as described in R 336.2040(8), including "W<sub>ci</sub>" and "L<sub>di</sub>."

(d) The average pounds of volatile organic compound per pound of solids, as applied, "P<sub>g</sub>," as described in R 336.2040(12).

(10) For graphic arts lines that have 1 or more add-on emissions control devices for which emission limits are expressed in pounds of volatile organic compounds per pound of solids, as applied, a person shall keep the following records:

(a) The name, identification number, volume "L<sub>ci</sub>" and volatile organic compound content of each ink and coating, minus water, as applied, "P," used during the averaging period, as described in R 336.2040(5).

(b) The weight of volatile organic compounds used during the averaging period "M," as described in R 336.2040(6).

(c) The weight of ink and coating solids used during the averaging period "W," as described in R 336.2040(8), including "W<sub>ci</sub>" and "L<sub>di</sub>."

(d) The overall capture efficiency "N," as described in R 336.2040(10).

(e) The overall reduction efficiency "R<sub>t</sub>," as described in R 336.2040(11), including the parameters "Q<sub>za</sub>," "C<sub>za</sub>," "Q<sub>im</sub>," "C<sub>im</sub>," and "M<sub>r</sub>."

(f) The average pounds of volatile organic compound per pound of solids, as applied, "P<sub>h</sub>" as described in R 336.2040(12).

(11) For flatwood paneling coating lines that do not have an add-on emissions control device for which emission limits are expressed in pounds of volatile organic compound per 1,000 square feet of coated finished product, a person shall keep the following records:

(a) The name, identification number, volume "L<sub>ci</sub>," and volatile organic compound content of each coating, minus water, as applied, "P," used during the averaging period, as described in R 336.2040(5).

(b) The weight of volatile organic compounds used during the averaging period "M," as described in R 336.2040(6).

(c) The total surface area of coated finished product for the coating category during the averaging period "sq," as described in R 336.2040(3).

(d) The volume-weighted average pounds of volatile organic compounds per 1,000 square feet of coated finished product "P<sub>i</sub>" as described in R 336.2040(12).

(12) For flatwood paneling coating lines that have 1 or more add-on emissions control devices for which emission limits are expressed in pounds of volatile organic compounds per 1,000 square feet of coated finished product, a person shall keep the following records:

(a) The name, identification number, volume "L<sub>ci</sub>" and volatile organic compound content of each coating, minus water, as applied, "P," used during the averaging period, as described in R 336.2040(5).

(b) The weight of volatile organic compounds used during the averaging period "M," as described in R 336.2040(6).

(c) The total surface area of coated finished product for the coating category during the averaging period "sq," as described in R 336.2040(3).

(d) The overall capture efficiency "N," as described in R 336.2040(10).

(e) The overall reduction efficiency "R<sub>t</sub>" as described in R 336.2040(11), including the parameters "Q<sub>za</sub>," "C<sub>za</sub>," "Q<sub>im</sub>," "C<sub>im</sub>," and "M<sub>r</sub>."

(f) The volume-weighted average pounds of volatile organic compounds per 1,000 square feet of coated finished product, as described in R 336.2040(12).

(13) An owner or operator of primer surfacer or topcoat operations subject to emission limits in R 336.1610(14), table 62, shall keep records as required in the publication entitled "Protocol for Determining the Daily Volatile Organic Compound Emission Rate of Automobile and Light-duty Truck Topcoat Operations, EPA-450/3-88-018, December, 1988, which is referenced in R 336.1610(8)(b).

(14) The records that are required in this rule shall be retained for a period of not less than 2 complete years from the date of collection and, upon request by the commission, shall be submitted to the commission in an acceptable format.

History: 1993 MR 4, Eff. Apr. 28, 1993.