

**AUTHORIZATION TO DISCHARGE UNDER THE
NATIONAL POLLUTANT DISCHARGE ELIMINATION SYSTEM**

In compliance with the provisions of the Federal Clean Water Act, as amended, (33 U.S.C. §§ 1251 et seq.; the "CWA"), and the Massachusetts Clean Waters Act, as amended, (M.G.L. Chap. 21, §§ 26-53),

Town of Lenox, Massachusetts

is authorized to discharge from the facility located at

**Lenox Wastewater Treatment Plant
239 Crystal Street
Lenox Dale, MA 01242**

to receiving water named

**Housatonic River
Housatonic River Watershed**

in accordance with effluent limitations, monitoring requirements and other conditions set forth herein.

This permit shall become effective on the first day of the calendar month immediately following 60 days after signature.¹

This permit expires at midnight, five years from the last day of the month preceding the effective date.

This permit supersedes the permit issued on September 12, 2007.

This permit consists of **Part I; Attachment A** (Freshwater Acute Toxicity Test Procedure and Protocol, February 2011); and **Part II** (NPDES Part II Standard Conditions, April 2018).

Signed this day of

Ken Moraff, Director
Water Division
Environmental Protection Agency
Region 1
Boston, MA

Lealdon Langley, Director
Division of Watershed Management
Department of Environmental Protection
Commonwealth of Massachusetts
Boston, MA

¹ Pursuant to 40 Code of Federal Regulations (C.F.R.) § 124.15(b)(3), if no comments requesting a change to the Draft Permit are received, the permit will become effective upon the date of signature.

PART I

A. EFFLUENT LIMITATIONS AND MONITORING REQUIREMENTS

1. 1. During the period beginning on the effective date and lasting through the expiration date, the Permittee is authorized to discharge treated effluent through Outfall Serial Number 001 to the Housatonic River. The discharge shall be limited and monitored as specified below; the receiving water and the influent shall be monitored as specified below.

Effluent Characteristic	Effluent Limitation			Monitoring Requirements ^{1,2,3}	
	Average Monthly ⁴	Average Weekly ⁴	Maximum Daily	Measurement Frequency	Sample Type ⁵
Effluent Flow ⁶	1.19 MGD	---	---	Continuous	Recorder
Effluent Flow ⁶	Report MGD	---	Report MGD	Continuous	Recorder
BOD ₅	30 mg/L 300 lb/day	45 mg/L 450 lb/day	Report mg/L	1/week	Composite
BOD ₅ Removal	≥ 85 %	---	---	---	---
TSS	30 mg/L 300 lb/day	45 mg/L 450 lb/day	Report mg/L	1/week	Composite
TSS Removal	≥ 85 %	---	---	---	---
pH Range ⁷	6.5 - 8.3 S.U.			1/day	Grab
Total Residual Chlorine ^{8,9}	230 µg/L	---	400 µg/L	1/day	Grab
<i>Escherichia coli</i> ^{8,9} (April 1 - Oct 31)	126 cfu/100 mL	---	409 cfu/100 mL	1/week	Grab
Aluminum ¹⁰	Report µg/L	---	Report µg/L	1/month	Composite
Phosphorus, Total ¹⁰ (April 1 - Oct 31)	0.22 mg/L Report lb/day	---	Report mg/L Report lb/day	1/week	Composite
Phosphorus, Total (November 1 – March 31)	1.0 mg/L Report lb/day	---	Report mg/L Report lb/day	1/week	Composite
Total Ammonia Nitrogen	Report mg/L	---	Report mg/L	1/month	Composite
Total Nitrogen ¹¹	Report mg/L 99 lb/day ¹²	---	Report mg/L Report lb/day	1/week	Composite
Total Kjeldahl Nitrogen ¹¹	Report mg/L	---	Report mg/L	1/week	Composite

Effluent Characteristic	Effluent Limitation			Monitoring Requirements ^{1,2,3}	
	Average Monthly ⁴	Average Weekly ⁴	Maximum Daily	Measurement Frequency	Sample Type ⁵
	Report lb/day				
Total Nitrate ¹¹	Report mg/L Report lb/day	---	Report mg/L	1/week	Composite
Total Nitrite ¹¹	Report mg/L Report lb/day	---	Report mg/L	1/week	Composite
Whole Effluent Toxicity (WET) Testing^{13,14}					
LC ₅₀	---	---	≥ 100 %	2/year	Composite
Hardness	---	---	Report mg/L	2/year	Composite
Ammonia Nitrogen	---	---	Report mg/L	2/year	Composite
Total Aluminum	---	---	Report µg/L	2/year	Composite
Total Cadmium	---	---	Report µg/L	2/year	Composite
Total Copper	---	---	Report µg/L	2/year	Composite
Total Nickel	---	---	Report µg/L	2/year	Composite
Total Lead	---	---	Report µg/L	2/year	Composite
Total Zinc	---	---	Report µg/L	2/year	Composite
Dissolved Organic Carbon			Report mg/L	2/year	Composite
Total Organic Carbon	---	---	Report mg/L	2/year	Composite

Ambient Characteristic ¹⁵	Reporting Requirements			Monitoring Requirements ^{1,2,3}	
	Average Monthly ⁴	Average Weekly ⁴	Maximum Daily	Measurement Frequency	Sample Type ⁵
Total Phosphorus	See Section G. Special Conditions				
Total Hardness	---	---	Report mg/L	2/year	Grab
Ammonia Nitrogen	---	---	Report mg/L	2/year	Grab
Total Aluminum	---	---	Report µg/L	2/year	Grab
Total Cadmium	---	---	Report µg/L	2/year	Grab
Total Copper	---	---	Report µg/L	2/year	Grab
Total Nickel	---	---	Report µg/L	2/year	Grab
Total Lead	---	---	Report µg/L	2/year	Grab
Total Zinc	---	---	Report µg/L	2/year	Grab
Total Organic Carbon	---	---	Report mg/L	2/year	Grab
Dissolved Organic Carbon	---	---	Report mg/L	2/year	Grab
pH ¹⁶	---	---	Report S.U.	2/year	Grab
Temperature ¹⁶	---	---	Report °C	2/year	Grab

Influent Characteristic	Reporting Requirements			Monitoring Requirements ^{1,2,3}	
	Average Monthly ⁴	Average Weekly ⁴	Maximum Daily	Measurement Frequency	Sample Type ⁵
BOD ₅	Report mg/L	---	---	2/month	Composite
TSS	Report mg/L	---	---	2/month	Composite

Footnotes:

1. Effluent samples shall yield data representative of the discharge. A routine sampling program shall be developed in which samples are taken at the same location, same time and same days of the week each month. The Permittee shall report the results to the Environmental Protection Agency Region 1 (EPA) and the State of any additional testing above that required herein, if testing is in accordance with 40 C.F.R. § 136.
2. In accordance with 40 C.F.R. § 122.44(i)(1)(iv), the Permittee shall monitor according to sufficiently sensitive test procedures (i.e., methods) approved under 40 C.F.R. Part 136 or required under 40 C.F.R. Chapter I, Subchapter N or O, for the analysis of pollutants or pollutant parameters (except WET). A method is “sufficiently sensitive” when: 1) The method minimum level (ML) is at or below the level of the effluent limitation established in the permit for the measured pollutant or pollutant parameter; or 2) The method has the lowest ML of the analytical methods approved under 40 C.F.R. Part 136 or required under 40 C.F.R. Chapter I, Subchapter N or O for the measured pollutant or pollutant parameter. The term “minimum level” refers to either the sample concentration equivalent to the lowest calibration point in a method or a multiple of the method detection limit (MDL), whichever is higher. Minimum levels may be obtained in several ways: They may be published in a method; they may be based on the lowest acceptable calibration point used by a laboratory; or they may be calculated by multiplying the MDL in a method, or the MDL determined by a laboratory, by a factor.
3. When a parameter is not detected above the ML, the Permittee must report the data qualifier signifying less than the ML for that parameter (e.g., < 50 µg/L, if the ML for a parameter is 50 µg/L).
4. In calculating and reporting the average monthly and weekly concentration when the pollutant is not detected, assign zero to the non-detected sample result if the pollutant was not detected for all monitoring periods in the prior twelve months. If the pollutant was detected in at least one monitoring period in the prior twelve months, then assign each non-detected sample result a value that is equal to one half of the minimum level of detection for the purposes of calculating averages.
5. Each composite sample will consist of at least twenty-four (24) grab samples taken during one consecutive 24-hour period, either collected at equal intervals and combined proportional to flow or continuously collected proportional to flow.
6. Report annual average, monthly average, and the maximum daily flow in million gallons per day (MGD). The limit is an annual average, which shall be reported as a rolling average. The value will be calculated as the arithmetic

mean of the monthly average flow for the reporting month and the monthly average flows of the previous eleven months.

7. The pH shall be within the specified range at all times. The minimum and maximum pH sample measurement values for the month shall be reported in standard units (S.U.).
8. The Permittee shall minimize the use of chlorine while maintaining adequate bacterial control. Monitoring for total residual chlorine (TRC) is only required for discharges which have been previously chlorinated or which contain residual chlorine. For the purposes of this permit, TRC analysis must be completed using a test method in 40 C.F.R. § 136 that achieves a minimum level no greater than 20 µg/L.

Chlorination and dechlorination systems shall include an alarm system for indicating system interruptions or malfunctions. Any interruption or malfunction of the chlorine dosing system that may have resulted in levels of chlorine that were inadequate for achieving effective disinfection, or interruptions or malfunctions of the dechlorination system that may have resulted in excessive levels of chlorine in the final effluent shall be reported with the monthly DMRs. The report shall include the date and time of the interruption or malfunction, the nature of the problem, and the estimated amount of time that the reduced levels of chlorine or dechlorination chemicals occurred.

9. The monthly average limit for *E. coli* is expressed as a geometric mean. *E. coli* monitoring shall be conducted concurrently with TRC monitoring if TRC monitoring is required.
10. See Part I.G., Special Conditions for a schedule of compliance.
11. Total Kjeldahl nitrogen, nitrite nitrogen, and nitrate nitrogen samples shall be collected concurrently. The results of these analyses shall be used to calculate both the concentration and mass loadings of total nitrogen.

(total nitrogen = total kjeldahl nitrogen + total nitrate nitrogen + total nitrite nitrogen)

The total nitrogen loading values reported each month shall be calculated as follows:

Total Nitrogen (lbs/day) = [(average monthly total nitrogen concentration (mg/l) * total monthly effluent flow (Millions of Gallons (MG)) / # of days in the month] *8.34

12. The total nitrogen limit is an annual average mass-based limit (lb/day), which shall be reported as a rolling average. The value will be calculated as the

arithmetic mean of the monthly average total nitrogen for the reporting month and the monthly average total nitrogen of the previous eleven months.

Report both the rolling annual average and the monthly average each month.

See Part I.G., Special Conditions for total nitrogen optimization requirements.

13. The Permittee shall conduct acute toxicity tests (LC₅₀) in accordance with test procedures and protocols specified in **Attachment A** of this permit. LC₅₀ is defined in Part II.E. of this permit. The Permittee shall test the daphnid, *Ceriodaphnia dubia*. Toxicity test samples shall be collected and tests completed during the same weeks each time of calendar months ending July 30th and October 31st. The complete report for each toxicity test shall be submitted as an attachment to the monthly DMR submittal immediately following the completion of the test.
14. For Part I.A.1., Whole Effluent Toxicity Testing, the Permittee shall conduct the analyses specified in **Attachment A**, Part VI. CHEMICAL ANALYSIS for the effluent sample. If toxicity test(s) using the receiving water as diluent show the receiving water to be toxic or unreliable, the Permittee shall follow procedures outlined in **Attachment A**, Section IV., DILUTION WATER. Minimum levels and test methods are specified in **Attachment A**, Part VI. CHEMICAL ANALYSIS.
15. For Part I.A.1., Ambient Characteristic, the Permittee shall conduct the analyses specified in **Attachment A**, Part VI. CHEMICAL ANALYSIS for the receiving water sample collected as part of the WET testing requirements. Such samples shall be taken from the receiving water at a point immediately upstream of the permitted discharge's zone of influence at a reasonably accessible location, as specified in **Attachment A**. Minimum levels and test methods are specified in **Attachment A**, Part VI. CHEMICAL ANALYSIS.
16. A pH and temperature measurement shall be taken of each receiving water sample at the time of collection and the results reported on the appropriate DMR. These pH and temperature measurements are independent from any pH and temperature measurements required by the WET testing protocols.

Part I.A. continued.

2. The discharge shall not cause a violation of the water quality standards of the receiving water.
3. The discharge shall be free from pollutants in concentrations or combinations that, in the receiving water, settle to form objectionable deposits; float as debris, scum or other matter to form nuisances; produce objectionable odor, color, taste or turbidity; or produce undesirable or nuisance species of aquatic life.
4. The discharge shall be free from pollutants in concentrations or combinations that adversely affect the physical, chemical, or biological nature of the bottom.
5. The discharge shall not result in pollutants in concentrations or combinations in the receiving water that are toxic to humans, aquatic life or wildlife.
6. The discharge shall be free from floating, suspended and settleable solids in concentrations or combinations that would impair any use assigned to the receiving water.
7. The discharge shall be free from oil, grease and petrochemicals that produce a visible film on the surface of the water, impart an oily taste to the water or an oily or other undesirable taste to the edible portions of aquatic life, coat the banks or bottom of the water course, or are deleterious or become toxic to aquatic life.
8. The Permittee must provide adequate notice to EPA-Region 1 and the State of the following:
 - a. Any new introduction of pollutants into the POTW from an indirect discharger which would be subject to § 301 or § 306 of the Clean Water Act if it were directly discharging those pollutants or in a primary industry category (see 40 C.F.R. § 122 Appendix A as amended) discharging process water; and
 - b. Any substantial change in the volume or character of pollutants being introduced into that POTW by a source introducing pollutants into the POTW at the time of issuance of the permit.
 - c. For purposes of this paragraph, adequate notice shall include information on:
 - (1) The quantity and quality of effluent introduced into the POTW; and
 - (2) Any anticipated impact of the change on the quantity or quality of effluent to be discharged from the POTW.
9. Pollutants introduced into the POTW by a non-domestic source (user) shall not pass through the POTW or interfere with the operation or performance of the works.

B. UNAUTHORIZED DISCHARGES

1. This permit authorizes discharges only from the outfall listed in Part I.A.1, in accordance with the terms and conditions of this permit. Discharges of wastewater from any other point sources, including sanitary sewer overflows (SSOs), are not authorized by this permit and shall be reported in accordance with Part D.1.e.(1) of the Standard Conditions of this permit (24-hour reporting).
2. Starting December 21, 2020, the Permittee must provide notification to the public within 24 hours of any unauthorized discharge on a publicly available web site. Such notification shall include the location and description of the discharge; estimated volume; the period of noncompliance, including exact dates and times, and, if the noncompliance has not been corrected, the anticipated time it is expected to continue.
3. Notification of SSOs to MassDEP shall be made on its SSO Reporting Form (which includes MassDEP Regional Office telephone numbers). The reporting form and instruction for its completion may be found on-line at <https://www.mass.gov/how-to/sanitary-sewer-overflowbypassbackup-notification>.

C. OPERATION AND MAINTENANCE OF THE SEWER SYSTEM

Operation and maintenance (O&M) of the sewer system shall be in compliance with the Standard Conditions of Part II and the following terms and conditions. The Permittee shall complete the following activities for the collection system which it owns:

1. Maintenance Staff

The Permittee shall provide an adequate staff to carry out the operation, maintenance, repair, and testing functions required to ensure compliance with the terms and conditions of this permit. Provisions to meet this requirement shall be described in the Collection System O&M Plan required pursuant to Section C.5. below.

2. Preventive Maintenance Program

The Permittee shall maintain an ongoing preventive maintenance program to prevent overflows and bypasses caused by malfunctions or failures of the sewer system infrastructure. The program shall include an inspection program designed to identify all potential and actual unauthorized discharges. Plans and programs to meet this requirement shall be described in the Collection System O&M Plan required pursuant to Section C.5. below.

3. Infiltration/Inflow

The Permittee shall control infiltration and inflow (I/I) into the sewer system as necessary to prevent high flow related unauthorized discharges from their collection systems and high

flow related violations of the wastewater treatment plant's effluent limitations. Plans and programs to control I/I shall be described in the Collection System O&M Plan required pursuant to Section C.5. below.

4. Collection System Mapping

Within 30 months of the effective date of this permit, the Permittee shall prepare a map of the sewer collection system it owns (see page 1 of this permit for the effective date). The map shall be on a street map of the community, with sufficient detail and at a scale to allow easy interpretation. The collection system information shown on the map shall be based on current conditions and shall be kept up-to-date and available for review by federal, state, or local agencies. Such map(s) shall include, but not be limited to the following:

- a. All sanitary sewer lines and related manholes;
- b. All combined sewer lines, related manholes, and catch basins;
- c. All combined sewer regulators and any known or suspected connections between the sanitary sewer and storm drain systems (e.g. combination manholes);
- d. All outfalls, including the treatment plant outfall(s), CSOs, and any known or suspected SSOs, including stormwater outfalls that are connected to combination manholes;
- e. All pump stations and force mains;
- f. The wastewater treatment facility(ies);
- g. All surface waters (labeled);
- h. Other major appurtenances such as inverted siphons and air release valves;
- i. A numbering system which uniquely identifies manholes, catch basins, overflow points, regulators and outfalls;
- j. The scale and a north arrow; and
- k. The pipe diameter, date of installation, type of material, distance between manholes, and the direction of flow.

5. Collection System O&M Plan

The Permittee shall develop and implement a Collection System O&M Plan.

- a. Within six (6) months of the effective date of the permit, the Permittee shall submit to EPA and the State

- (1) A description of the collection system management goals, staffing, information management, and legal authorities;
 - (2) A description of the collection system and the overall condition of the collection system including a list of all pump stations and a description of recent studies and construction activities; and
 - (3) A schedule for the development and implementation of the full Collection System O&M Plan including the elements in paragraphs b.1. through b.8. below.
- b. The full Collection System O&M Plan shall be completed, implemented and submitted to EPA and the State within twenty-four (24) months from the effective date of this permit. The Plan shall include:
- (1) The required submittal from paragraph 5.a. above, updated to reflect current information;
 - (2) A preventive maintenance and monitoring program for the collection system;
 - (3) Description of sufficient staffing necessary to properly operate and maintain the sanitary sewer collection system and how the operation and maintenance program is staffed;
 - (4) Description of funding, the source(s) of funding and provisions for funding sufficient for implementing the plan;
 - (5) Identification of known and suspected overflows and back-ups, including manholes. A description of the cause of the identified overflows and back-ups, corrective actions taken, and a plan for addressing the overflows and back-ups consistent with the requirements of this permit;
 - (6) A description of the Permittee's programs for preventing I/I related effluent violations and all unauthorized discharges of wastewater, including overflows and by-passes and the ongoing program to identify and remove sources of I/I. The program shall include an inflow identification and control program that focuses on the disconnection and redirection of illegal sump pumps and roof down spouts;
 - (7) An educational public outreach program for all aspects of I/I control, particularly private inflow; and
 - (8) An Overflow Emergency Response Plan to protect public health from overflows and unanticipated bypasses or upsets that exceed any effluent limitation in the permit

6. Annual Reporting Requirement

The Permittee shall submit a summary report of activities related to the implementation of its Collection System O&M Plan during the previous calendar year. The report shall be submitted to EPA and the State annually by March 31. The first annual report is due the first March 31 following submittal of the collection system O&M Plan required by Part I.C.5.b. of this permit. The summary report shall, at a minimum, include:

- a. A description of the staffing levels maintained during the year;
- b. A map and a description of inspection and maintenance activities conducted and corrective actions taken during the previous year;

- c. Expenditures for any collection system maintenance activities and corrective actions taken during the previous year;
- d. A map with areas identified for investigation/action in the coming year;
- e. A summary of unauthorized discharges during the past year and their causes and a report of any corrective actions taken as a result of the unauthorized discharges reported pursuant to the Unauthorized Discharges section of this permit; and
- f. If the average annual flow in the previous calendar year exceeded 80 percent of the facility's 1.19 MGD design flow (0.95 MGD), or there have been capacity related overflows, the report shall include:
 - (1) Plans for further potential flow increases describing how the Permittee will maintain compliance with the flow limit and all other effluent limitations and conditions; and
 - (2) A calculation of the maximum daily, weekly, and monthly infiltration and the maximum daily, weekly, and monthly inflow for the reporting year.

D. ALTERNATE POWER SOURCE

In order to maintain compliance with the terms and conditions of this permit, the Permittee shall provide an alternative power source(s) sufficient to operate the portion of the publicly owned treatment works it owns and operates, as defined in Part II.E.1 of this permit.

E. INDUSTRIAL USERS

1. The Permittee shall submit to EPA and the State the name of any Industrial User (IU) subject to Categorical Pretreatment Standards under 40 C.F.R. § 403.6 and 40 C.F.R. Chapter I, Subchapter N (§§ 405-415, 417-436, 439-440, 443, 446-447, 454-455, 457-461, 463-469, and 471 as amended) who commences discharge to the POTW after the effective date of this permit.

This reporting requirement also applies to any other IU who discharges an average of 25,000 gallons per day or more of process wastewater into the POTW (excluding sanitary, noncontact cooling and boiler blowdown wastewater); contributes a process wastewater which makes up five (5) percent or more of the average dry weather hydraulic or organic capacity of the POTW; or is designated as such by the Control Authority as defined in 40 C.F.R. § 403.12(a) on the basis that the industrial user has a reasonable potential to adversely affect the wastewater treatment facility's operation, or for violating any pretreatment standard or requirement (in accordance with 40 C.F.R. § 403.8(f)(6)).

2. In the event that the Permittee receives reports (baseline monitoring reports, 90-day compliance reports, periodic reports on continued compliance, etc.) from industrial users subject to Categorical Pretreatment Standards under 40 C.F.R. § 403.6 and 40 C.F.R. Chapter

I, Subchapter N (§§ 405-415, 417-436, 439-440, 443, 446-447, 454-455, 457-461, 463-469, and 471 as amended), the Permittee shall forward all copies of these reports within ninety (90) days of their receipt to EPA and the State.

F. SLUDGE CONDITIONS

1. The Permittee shall comply with all existing federal and state laws and regulations that apply to sewage sludge use and disposal practices, including EPA regulations promulgated at 40 C.F.R. § 503, which prescribe “Standards for the Use or Disposal of Sewage Sludge” pursuant to § 405(d) of the CWA, 33 U.S.C. § 1345(d).
2. If both state and federal requirements apply to the Permittee’s sludge use and/or disposal practices, the Permittee shall comply with the more stringent of the applicable requirements.
3. The requirements and technical standards of 40 C.F.R. § 503 apply to the following sludge use or disposal practices:
 - a. Land application - the use of sewage sludge to condition or fertilize the soil
 - b. Surface disposal - the placement of sewage sludge in a sludge only landfill
 - c. Sewage sludge incineration in a sludge only incinerator
4. The requirements of 40 C.F.R. § 503 do not apply to facilities which dispose of sludge in a municipal solid waste landfill. 40 C.F.R. § 503.4. These requirements also do not apply to facilities which do not use or dispose of sewage sludge during the life of the permit but rather treat the sludge (e.g., lagoons, reed beds), or are otherwise excluded under 40 C.F.R. § 503.6.
5. The 40 C.F.R. § 503 requirements include the following elements:
 - General requirements
 - Pollutant limitations
 - Operational Standards (pathogen reduction requirements and vector attraction reduction requirements)
 - Management practices
 - Record keeping
 - Monitoring
 - Reporting

Which of the 40 C.F.R. § 503 requirements apply to the Permittee will depend upon the use or disposal practice followed and upon the quality of material produced by a facility. The EPA Region 1 Guidance document, “EPA Region 1 - NPDES Permit Sludge Compliance Guidance” (November 4, 1999), may be used by the Permittee to assist it in determining the applicable requirements.²

² This guidance document is available upon request from EPA Region 1 and may also be found at: <http://www.epa.gov/region1/npdes/permits/generic/sludgeguidance.pdf>

6. The sludge shall be monitored for pollutant concentrations (all Part 503 methods) and pathogen reduction and vector attraction reduction (land application and surface disposal) at the following frequency. This frequency is based upon the volume of sewage sludge generated at the facility in dry metric tons per year, as follows:

less than 290	1/ year
290 to less than 1,500	1 /quarter
1,500 to less than 15,000	6 /year
15,000 +	1 /month

Sampling of the sewage sludge shall use the procedures detailed in 40 C.F.R. § 503.8.

7. Under 40 C.F.R. § 503.9(r), the Permittee is a “person who prepares sewage sludge” because it “is ... the person who generates sewage sludge during the treatment of domestic sewage in a treatment works ...” If the Permittee contracts with *another* “person who prepares sewage sludge” under 40 C.F.R. § 503.9(r) – i.e., with “a person who derives a material from sewage sludge” – for use or disposal of the sludge, then compliance with § 503 requirements is the responsibility of the contractor engaged for that purpose. If the Permittee does not engage a “person who prepares sewage sludge,” as defined in 40 C.F.R. § 503.9(r), for use or disposal, then the Permittee remains responsible to ensure that the applicable requirements in § 503 are met. 40 C.F.R. § 503.7. If the ultimate use or disposal method is land application, the Permittee is responsible for providing the person receiving the sludge with notice and necessary information to comply with the requirements of 40 C.F.R. § 503 Subpart B.
8. The Permittee shall submit an annual report containing the information specified in the 40 C.F.R. § 503 requirements (§ 503.18 (land application), § 503.28 (surface disposal), or § 503.48 (incineration)) by **February 19** (*see also* “EPA Region 1 - NPDES Permit Sludge Compliance Guidance”). Reports shall be submitted electronically using EPA’s Electronic Reporting tool (“NeT”) (*see* “Reporting Requirements” section below).

G. SPECIAL CONDITIONS

1. Total Phosphorus

The permittee shall meet the summer (April 1 through October 31) total phosphorus effluent of 0.22 mg/L within 12 months of the effective date of the permit. Until such date the limit of 1.0 mg/L total phosphorus shall remain in effect.

2. Total Phosphorus Ambient Monitoring

The Permittee shall develop and implement a sampling and analysis plan for biannually collecting monthly samples from the Housatonic River at a location upstream of the facility. Samples shall be collected during even numbered years, once per month, from May through September, during dry weather at Station W1117, Woods Pond at the footbridge east of Housatonic Street, Lenox (Latitude 42.349736, Longitude -73.24384). Dry weather is defined as any calendar day that is preceded by

at least 72 hours without rainfall, following the last rainfall of 0.1 inch of rainfall or greater. The sampling plan shall be submitted to EPA and DEP as part of a Quality Assurance Project Plan for review and approval at least three months prior to the first planned sampling date.

3. Total Nitrogen

- a. **Within one year of the effective date** of the permit, the permittee shall complete an evaluation of alternative methods of operating the existing wastewater treatment facility to optimize the removal of nitrogen in order to minimize the annual average mass discharge of total nitrogen, and submit a report to EPA and MassDEP documenting this evaluation and presenting a description of recommended operational changes. The methods to be evaluated include, but are not limited to, operational changes designed to enhance nitrification (seasonal and year-round), incorporation of anoxic zones, septage receiving policies and procedures, and side stream management. This report may be combined with the permittees' annual nitrogen report under Part I.B.1.b, if both reports are submitted to EPA and MassDEP by February 1st.
- b. The permittee shall also submit an annual report to EPA and the MassDEP, by **February 1st** each year, that summarizes activities related to optimizing nitrogen removal efficiencies, documents the annual nitrogen discharge load from the facility, and tracks trends relative to the previous year. If, in any year, the treatment facility discharges of TN on an average annual basis have increased, the annual report shall include a detailed explanation of the reasons why TN discharges have increased, including any changes in influent flows/loads and any operational changes. The report shall also include all supporting data.

H. REPORTING REQUIREMENTS

Unless otherwise specified in this permit, the Permittee shall submit reports, requests, and information and provide notices in the manner described in this section.

1. Submittal of DMRs Using NetDMR

The Permittee shall continue to submit its monthly monitoring data in discharge monitoring reports (DMRs) to EPA and the State no later than the 15th day of the month electronically using NetDMR. When the Permittee submits DMRs using NetDMR, it is not required to submit hard copies of DMRs to EPA or the State. NetDMR is accessed from the internet at <https://netdmr.zendesk.com/hc/en-us>.

2. Submittal of Reports as NetDMR Attachments

Unless otherwise specified in this permit, the Permittee shall electronically submit all reports to EPA as NetDMR attachments rather than as hard copies. *See* Part I.H.7. for more

information on State reporting. Because the due dates for reports described in this permit may not coincide with the due date for submitting DMRs (which is no later than the 15th day of the month), a report submitted electronically as a NetDMR attachment shall be considered timely if it is electronically submitted to EPA using NetDMR with the next DMR due following the report due date specified in this permit.

3. Submittal of Biosolids/Sewage Sludge Reports

By February 19 of each year, the Permittee must electronically report their annual Biosolids/Sewage Sludge Report for the previous calendar year using EPA's NPDES Electronic Reporting Tool ("NeT") found on the internet at <https://www.epa.gov/compliance/npdes-ereporting>.

4. Submittal of Requests and Reports to EPA/WD

a. The following requests, reports, and information described in this permit shall be submitted to the EPA/WD NPDES Applications Coordinator in the EPA Water Division (WD):

- (1) Transfer of permit notice;
- (2) Request for changes in sampling location;
- (3) Report on unacceptable dilution water / request for alternative dilution water for WET testing; and,
- (4) Report of new or potential industrial user commencing discharge.

b. These reports, information, and requests shall be submitted to EPA/WD electronically at R1npdesreports@epa.gov or by hard copy mail to the following address:

**U.S. Environmental Protection Agency
Water Division
EPA/WD NPDES Applications Coordinator
5 Post Office Square - Suite 100 (06-03)
Boston, MA 02109-3912**

5. Submittal of Reports in Hard Copy Form

a. The following notifications and reports shall be signed and dated originals, submitted as hard copy, with a cover letter describing the submission:

- (1) Written notifications required under Part II
- (2) Notice of unauthorized discharges, including Sanitary Sewer Overflow (SSO) reporting

b. This information shall be submitted to EPA/ECAD at the following address:

**U.S. Environmental Protection Agency
Enforcement and Compliance Assurance Division (ECAD)
Water Technical Unit
5 Post Office Square, Suite 100 (04-SMR)
Boston, MA 02109-3912**

6. State Reporting

Duplicate signed copies of all WET test reports shall be submitted to the Massachusetts Department of Environmental Protection, Division of Watershed Management, at the following address:

**Massachusetts Department of Environmental Protection
Bureau of Water Resources
Division of Watershed Management
8 New Bond Street
Worcester, Massachusetts 01606**

7. Verbal Reports and Verbal Notifications

- a. Any verbal reports or verbal notifications, if required in Parts I and/or II of this permit, shall be made to both EPA and to the State. This includes verbal reports and notifications which require reporting within 24 hours (e.g., Part II.B.4.c. (2), Part II.B.5.c. (3), and Part II.D.1.e.).
- b. Verbal reports and verbal notifications shall be made to EPA's Enforcement and Compliance Assurance Division at:

EPA's Office of Environmental Stewardship: 617-918-1510

and

MassDEP's Emergency Response: 888-304-1133

I. STATE PERMIT CONDITIONS

1. This authorization to discharge includes two separate and independent permit authorizations. The two permit authorizations are 1) a Federal National Pollutant Discharge Elimination System permit issued by the U.S. Environmental Protection Agency (EPA) pursuant to the Federal Clean Water Act, 33 U.S.C. §§ 1251 *et seq.*; and 2) an identical State surface water discharge permit issued by the Commissioner of the Massachusetts Department of Environmental Protection (MassDEP) pursuant to the Massachusetts Clean Waters Act, M.G.L. c. 21, §§ 26-53, and 314 CMR 3.00. All of the requirements contained in this authorization, as well as the standard conditions contained in 314 CMR 3.19, are hereby incorporated by reference into this State surface water discharge permit.

2. This authorization also incorporates the State water quality certification issued by MassDEP under § 401(a) of the Federal Clean Water Act, 40 C.F.R. 124.53, M.G.L. c. 21, § 27 and 314 CMR 3.07. All of the requirements (if any) contained in MassDEP's water quality certification for the permit are hereby incorporated by reference into this State surface water discharge permit as special conditions pursuant to 314 CMR 3.11.
3. Each agency shall have the independent right to enforce the terms and conditions of this permit. Any modification, suspension or revocation of this permit shall be effective only with respect to the agency taking such action, and shall not affect the validity or status of this permit as issued by the other agency, unless and until each agency has concurred in writing with such modification, suspension or revocation. In the event any portion of this permit is declared invalid, illegal or otherwise issued in violation of state law such permit shall remain in full force and effect under federal law as a NPDES Permit issued by the EPA. In the event this permit is declared invalid, illegal or otherwise issued in violation of Federal law, this permit shall remain in full force and effect under State law as a permit issued by the Commonwealth of Massachusetts.

ATTACHMENT A

USEPA REGION 1 FRESHWATER ACUTE TOXICITY TEST PROCEDURE AND PROTOCOL

I. GENERAL REQUIREMENTS

The permittee shall conduct acceptable acute toxicity tests in accordance with the appropriate test protocols described below:

- **Daphnid (Ceriodaphnia dubia) definitive 48 hour test.**
- **Fathead Minnow (Pimephales promelas) definitive 48 hour test.**

Acute toxicity test data shall be reported as outlined in Section VIII.

II. METHODS

The permittee shall use 40 CFR Part 136 methods. Methods and guidance may be found at:

http://water.epa.gov/scitech/methods/cwa/wet/disk2_index.cfm

The permittee shall also meet the sampling, analysis and reporting requirements included in this protocol. This protocol defines more specific requirements while still being consistent with the Part 136 methods. If, due to modifications of Part 136, there are conflicting requirements between the Part 136 method and this protocol, the permittee shall comply with the requirements of the Part 136 method.

III. SAMPLE COLLECTION

A discharge sample shall be collected. Aliquots shall be split from the sample, containerized and preserved (as per 40 CFR Part 136) for chemical and physical analyses required. The remaining sample shall be measured for total residual chlorine and dechlorinated (if detected) in the laboratory using sodium thiosulfate for subsequent toxicity testing. (Note that EPA approved test methods require that samples collected for metals analyses be preserved immediately after collection.) Grab samples must be used for pH, temperature, and total residual chlorine (as per 40 CFR Part 122.21).

Standard Methods for the Examination of Water and Wastewater describes dechlorination of samples (APHA, 1992). Dechlorination can be achieved using a ratio of 6.7 mg/L anhydrous sodium thiosulfate to reduce 1.0 mg/L chlorine. If dechlorination is necessary, a thiosulfate control (maximum amount of thiosulfate in lab control or receiving water) must also be run in the WET test.

All samples held overnight shall be refrigerated at 1- 6°C.

IV. DILUTION WATER

A grab sample of dilution water used for acute toxicity testing shall be collected from the receiving water at a point immediately upstream of the permitted discharge's zone of influence at a reasonably accessible location. Avoid collection near areas of obvious road or agricultural runoff, storm sewers or other point source discharges and areas where stagnant conditions exist. In the case where an alternate dilution water has been agreed upon an additional receiving water control (0% effluent) must also be tested.

If the receiving water diluent is found to be, or suspected to be toxic or unreliable, an alternate standard dilution water of known quality with a hardness, pH, conductivity, alkalinity, organic carbon, and total suspended solids similar to that of the receiving water may be substituted **AFTER RECEIVING WRITTEN APPROVAL FROM THE PERMIT ISSUING AGENCY(S)**. Written requests for use of an alternate dilution water should be mailed with supporting documentation to the following address:

Director
Office of Ecosystem Protection (CAA)
U.S. Environmental Protection Agency-New England
5 Post Office Sq., Suite 100 (OEP06-5)
Boston, MA 02109-3912

and

Manager
Water Technical Unit (SEW)
U.S. Environmental Protection Agency
5 Post Office Sq., Suite 100 (OES04-4)
Boston, MA 02109-3912

Note: USEPA Region 1 retains the right to modify any part of the alternate dilution water policy stated in this protocol at any time. Any changes to this policy will be documented in the annual DMR posting.

See the most current annual DMR instructions which can be found on the EPA Region 1 website at <http://www.epa.gov/region1/enforcement/water/dmr.html> for further important details on alternate dilution water substitution requests.

It may prove beneficial to have the proposed dilution water source screened for suitability prior to toxicity testing. EPA strongly urges that screening be done prior to set up of a full definitive toxicity test any time there is question about the dilution water's ability to support acceptable performance as outlined in the 'test acceptability' section of the protocol.

V. TEST CONDITIONS

The following tables summarize the accepted daphnid and fathead minnow toxicity test conditions and test acceptability criteria:

EPA NEW ENGLAND EFFLUENT TOXICITY TEST CONDITIONS FOR THE DAPHNID, CERIODAPHNIA DUBIA 48 HOUR ACUTE TESTS¹

1.	Test type	Static, non-renewal
2.	Temperature (°C)	20 ± 1°C or 25 ± 1°C
3.	Light quality	Ambient laboratory illumination
4.	Photoperiod	16 hour light, 8 hour dark
5.	Test chamber size	Minimum 30 ml
6.	Test solution volume	Minimum 15 ml
7.	Age of test organisms	1-24 hours (neonates)
8.	No. of daphnids per test chamber	5
9.	No. of replicate test chambers per treatment	4
10.	Total no. daphnids per test concentration	20
11.	Feeding regime	As per manual, lightly feed YCT and <u>Selenastrum</u> to newly released organisms while holding prior to initiating test
12.	Aeration	None
13.	Dilution water ²	Receiving water, other surface water, synthetic water adjusted to the hardness and alkalinity of the receiving water (prepared using either Millipore Milli-Q ^R or equivalent deionized water and reagent grade chemicals according to EPA acute toxicity test manual) or deionized water combined with mineral water to appropriate hardness.
14.	Dilution series	≥ 0.5, must bracket the permitted RWC
15.	Number of dilutions	5 plus receiving water and laboratory water control and thiosulfate control, as necessary. An additional dilution at the permitted effluent concentration (% effluent) is required if it is not included in the dilution

series.

- | | |
|----------------------------|---|
| 16. Effect measured | Mortality-no movement of body or appendages on gentle prodding |
| 17. Test acceptability | 90% or greater survival of test organisms in dilution water control solution |
| 18. Sampling requirements | For on-site tests, samples must be used within 24 hours of the time that they are removed from the sampling device. For off-site tests, samples must first be used within 36 hours of collection. |
| 19. Sample volume required | Minimum 1 liter |

Footnotes:

1. Adapted from EPA-821-R-02-012.
2. Standard prepared dilution water must have hardness requirements to generally reflect the characteristics of the receiving water.

**EPA NEW ENGLAND TEST CONDITIONS FOR THE FATHEAD MINNOW
(PIMEPHALES PROMELAS) 48 HOUR ACUTE TEST¹**

1. Test Type	Static, non-renewal
2. Temperature (°C)	20 ± 1 ° C or 25 ± 1°C
3. Light quality	Ambient laboratory illumination
4. Photoperiod	16 hr light, 8 hr dark
5. Size of test vessels	250 mL minimum
6. Volume of test solution	Minimum 200 mL/replicate
7. Age of fish	1-14 days old and age within 24 hrs of each other
8. No. of fish per chamber	10
9. No. of replicate test vessels per treatment	4
10. Total no. organisms per concentration	40
11. Feeding regime	As per manual, lightly feed test age larvae using concentrated brine shrimp nauplii while holding prior to initiating test
12. Aeration	None, unless dissolved oxygen (D.O.) concentration falls below 4.0 mg/L, at which time gentle single bubble aeration should be started at a rate of less than 100 bubbles/min. (Routine D.O. check is recommended.)
13. dilution water ²	Receiving water, other surface water, synthetic water adjusted to the hardness and alkalinity of the receiving water (prepared using either Millipore Milli-Q ^R or equivalent deionized and reagent grade chemicals according to EPA acute toxicity test manual) or deionized water combined with mineral water to appropriate hardness.
14. Dilution series	≥ 0.5, must bracket the permitted RWC

- | | |
|----------------------------|--|
| 15. Number of dilutions | 5 plus receiving water and laboratory water control and thiosulfate control, as necessary. An additional dilution at the permitted effluent concentration (% effluent) is required if it is not included in the dilution series. |
| 16. Effect measured | Mortality-no movement on gentle prodding |
| 17. Test acceptability | 90% or greater survival of test organisms in dilution water control solution |
| 18. Sampling requirements | For on-site tests, samples must be used within 24 hours of the time that they are removed from the sampling device. For off-site tests, samples are used within 36 hours of collection. |
| 19. Sample volume required | Minimum 2 liters |

Footnotes:

1. Adapted from EPA-821-R-02-012
2. Standard dilution water must have hardness requirements to generally reflect characteristics of the receiving water.

VI. CHEMICAL ANALYSIS

At the beginning of a static acute toxicity test, pH, conductivity, total residual chlorine, oxygen, hardness, alkalinity and temperature must be measured in the highest effluent concentration and the dilution water. Dissolved oxygen, pH and temperature are also measured at 24 and 48 hour intervals in all dilutions. The following chemical analyses shall be performed on the 100 percent effluent sample and the upstream water sample for each sampling event.

<u>Parameter</u>	Effluent	Receiving Water	ML (mg/l)
Hardness ¹	x	x	0.5
Total Residual Chlorine (TRC) ^{2, 3}	x		0.02
Alkalinity	x	x	2.0
pH	x	x	--
Specific Conductance	x	x	--
Total Solids	x		--
Total Dissolved Solids	x		--
Ammonia	x	x	0.1
Total Organic Carbon	x	x	0.5
Total Metals			
Cd	x	x	0.0005
Pb	x	x	0.0005
Cu	x	x	0.003
Zn	x	x	0.005
Ni	x	x	0.005
Al	x	x	0.02
Other as permit requires			

Notes:

- Hardness may be determined by:
 - APHA Standard Methods for the Examination of Water and Wastewater , 21st Edition
 - Method 2340B (hardness by calculation)
 - Method 2340C (titration)
- Total Residual Chlorine may be performed using any of the following methods provided the required minimum limit (ML) is met.
 - APHA Standard Methods for the Examination of Water and Wastewater , 21st Edition
 - Method 4500-CL E Low Level Amperometric Titration
 - Method 4500-CL G DPD Colorimetric Method
- Required to be performed on the sample used for WET testing prior to its use for toxicity testing.

VII. TOXICITY TEST DATA ANALYSIS

LC50 Median Lethal Concentration (Determined at 48 Hours)

Methods of Estimation:

- Probit Method
- Spearman-Kärber
- Trimmed Spearman-Kärber
- Graphical

See the flow chart in Figure 6 on p. 73 of EPA-821-R-02-012 for appropriate method to use on a given data set.

No Observed Acute Effect Level (NOAEL)

See the flow chart in Figure 13 on p. 87 of EPA-821-R-02-012.

VIII. TOXICITY TEST REPORTING

A report of the results will include the following:

- Description of sample collection procedures, site description
- Names of individuals collecting and transporting samples, times and dates of sample collection and analysis on chain-of-custody
- General description of tests: age of test organisms, origin, dates and results of standard toxicant tests; light and temperature regime; other information on test conditions if different than procedures recommended. Reference toxicant test data should be included.
- All chemical/physical data generated. (Include minimum detection levels and minimum quantification levels.)
- Raw data and bench sheets.
- Provide a description of dechlorination procedures (as applicable).
- Any other observations or test conditions affecting test outcome.

NPDES PART II STANDARD CONDITIONS
(April 26, 2018)¹

TABLE OF CONTENTS

	Page
A. GENERAL CONDITIONS	
1. <u>Duty to Comply</u>	2
2. <u>Permit Actions</u>	3
3. <u>Duty to Provide Information</u>	4
4. <u>Oil and Hazardous Substance Liability</u>	4
5. <u>Property Rights</u>	4
6. <u>Confidentiality of Information</u>	4
7. <u>Duty to Reapply</u>	4
8. <u>State Authorities</u>	4
9. <u>Other laws</u>	5
B. OPERATION AND MAINTENANCE OF POLLUTION CONTROLS	
1. <u>Proper Operation and Maintenance</u>	5
2. <u>Need to Halt or Reduce Not a Defense</u>	5
3. <u>Duty to Mitigate</u>	5
4. <u>Bypass</u>	5
5. <u>Upset</u>	6
C. MONITORING AND RECORDS	
1. <u>Monitoring and Records</u>	7
2. <u>Inspection and Entry</u>	8
D. REPORTING REQUIREMENTS	
1. <u>Reporting Requirements</u>	8
a. Planned changes	8
b. Anticipated noncompliance	8
c. Transfers	9
d. Monitoring reports	9
e. Twenty-four hour reporting	9
f. Compliance schedules	10
g. Other noncompliance	10
h. Other information	10
i. Identification of the initial recipient for NPDES electronic reporting data	11
2. <u>Signatory Requirement</u>	11
3. <u>Availability of Reports</u>	11
E. DEFINITIONS AND ABBREVIATIONS	
1. <u>General Definitions</u>	11
2. <u>Commonly Used Abbreviations</u>	20

¹Updated July 17, 2018 to fix typographical errors.

NPDES PART II STANDARD CONDITIONS
(April 26, 2018)

A. GENERAL REQUIREMENTS

1. Duty to Comply

The Permittee must comply with all conditions of this permit. Any permit noncompliance constitutes a violation of the Clean Water Act (CWA or Act) and is grounds for enforcement action; for permit termination, revocation and reissuance, or modification; or denial of a permit renewal application.

- a. The Permittee shall comply with effluent standards or prohibitions established under Section 307(a) of the Clean Water Act for toxic pollutants and with standards for sewage sludge use or disposal established under Section 405(d) of the CWA within the time provided in the regulations that establish these standards or prohibitions, or standards for sewage sludge use or disposal, even if the permit has not yet been modified to incorporate the requirement.
- b. Penalties for Violations of Permit Conditions: The Director will adjust the civil and administrative penalties listed below in accordance with the Civil Monetary Penalty Inflation Adjustment Rule (83 Fed. Reg. 1190-1194 (January 10, 2018) and the 2015 amendments to the Federal Civil Penalties Inflation Adjustment Act of 1990, 28 U.S.C. § 2461 note. See Pub. L.114-74, Section 701 (Nov. 2, 2015)). These requirements help ensure that EPA penalties keep pace with inflation. Under the above-cited 2015 amendments to inflationary adjustment law, EPA must review its statutory civil penalties each year and adjust them as necessary.

(1) Criminal Penalties

- (a) *Negligent Violations.* The CWA provides that any person who negligently violates permit conditions implementing Sections 301, 302, 306, 307, 308, 318, or 405 of the Act is subject to criminal penalties of not less than \$2,500 nor more than \$25,000 per day of violation, or imprisonment of not more than 1 year, or both. In the case of a second or subsequent conviction for a negligent violation, a person shall be subject to criminal penalties of not more than \$50,000 per day of violation or by imprisonment of not more than 2 years, or both.
- (b) *Knowing Violations.* The CWA provides that any person who knowingly violates permit conditions implementing Sections 301, 302, 306, 307, 308, 318, or 405 of the Act is subject to a fine of not less than \$5,000 nor more than \$50,000 per day of violation, or by imprisonment for not more than 3 years, or both. In the case of a second or subsequent conviction for a knowing violation, a person shall be subject to criminal penalties of not more than \$100,000 per day of violation, or imprisonment of not more than 6 years, or both.
- (c) *Knowing Endangerment.* The CWA provides that any person who knowingly violates permit conditions implementing Sections 301, 302, 303, 306, 307, 308, 318, or 405 of the Act and who knows at that time that he or she is placing another person in imminent danger of death or serious bodily injury shall upon conviction be subject to a fine of not more than \$250,000 or by imprisonment of not more than 15 years, or both. In the case of a second or subsequent conviction for a knowing

NPDES PART II STANDARD CONDITIONS

(April 26, 2018)

endangerment violation, a person shall be subject to a fine of not more than \$500,000 or by imprisonment of not more than 30 years, or both. An organization, as defined in Section 309(c)(3)(B)(iii) of the Act, shall, upon conviction of violating the imminent danger provision, be subject to a fine of not more than \$1,000,000 and can be fined up to \$2,000,000 for second or subsequent convictions.

- (d) *False Statement.* The CWA provides that any person who falsifies, tampers with, or knowingly renders inaccurate any monitoring device or method required to be maintained under this permit shall, upon conviction, be punished by a fine of not more than \$10,000, or by imprisonment for not more than 2 years, or both. If a conviction of a person is for a violation committed after a first conviction of such person under this paragraph, punishment is a fine of not more than \$20,000 per day of violation, or by imprisonment of not more than 4 years, or both. The Act further provides that any person who knowingly makes any false statement, representation, or certification in any record or other document submitted or required to be maintained under this permit, including monitoring reports or reports of compliance or non-compliance shall, upon conviction, be punished by a fine of not more than \$10,000 per violation, or by imprisonment for not more than 6 months per violation, or by both.
- (2) *Civil Penalties.* The CWA provides that any person who violates a permit condition implementing Sections 301, 302, 306, 307, 308, 318, or 405 of the Act is subject to a civil penalty not to exceed the maximum amounts authorized by Section 309(d) of the Act, the 2015 amendments to the Federal Civil Penalties Inflation Adjustment Act of 1990, 28 U.S.C. § 2461 note, and 40 C.F.R. Part 19. *See* Pub. L.114-74, Section 701 (Nov. 2, 2015); 83 Fed. Reg. 1190 (January 10, 2018).
- (3) *Administrative Penalties.* The CWA provides that any person who violates a permit condition implementing Sections 301, 302, 306, 307, 308, 318, or 405 of the Act is subject to an administrative penalty as follows:
- (a) *Class I Penalty.* Not to exceed the maximum amounts authorized by Section 309(g)(2)(A) of the Act, the 2015 amendments to the Federal Civil Penalties Inflation Adjustment Act of 1990, 28 U.S.C. § 2461 note, and 40 C.F.R. Part 19. *See* Pub. L.114-74, Section 701 (Nov. 2, 2015); 83 Fed. Reg. 1190 (January 10, 2018).
- (b) *Class II Penalty.* Not to exceed the maximum amounts authorized by Section 309(g)(2)(B) of the Act the 2015 amendments to the Federal Civil Penalties Inflation Adjustment Act of 1990, 28 U.S.C. § 2461 note, and 40 C.F.R. Part 19. *See* Pub. L.114-74, Section 701 (Nov. 2, 2015); 83 Fed. Reg. 1190 (January 10, 2018).

2. Permit Actions

This permit may be modified, revoked and reissued, or terminated for cause. The filing of a request by the Permittee for a permit modification, revocation and reissuance, or termination, or a notification of planned changes or anticipated noncompliance does not stay any permit

NPDES PART II STANDARD CONDITIONS
(April 26, 2018)

condition.

3. Duty to Provide Information

The Permittee shall furnish to the Director, within a reasonable time, any information which the Director may request to determine whether cause exists for modifying, revoking and reissuing, or terminating this permit, or to determine compliance with this permit. The Permittee shall also furnish to the Director, upon request, copies of records required to be kept by this permit.

4. Oil and Hazardous Substance Liability

Nothing in this permit shall be construed to preclude the institution of any legal action or relieve the Permittee from responsibilities, liabilities or penalties to which the Permittee is or may be subject under Section 311 of the CWA, or Section 106 of the Comprehensive Environmental Response, Compensation and Liability Act of 1980 (CERCLA).

5. Property Rights

This permit does not convey any property rights of any sort, or any exclusive privilege.

6. Confidentiality of Information

a. In accordance with 40 C.F.R. Part 2, any information submitted to EPA pursuant to these regulations may be claimed as confidential by the submitter. Any such claim must be asserted at the time of submission in the manner prescribed on the application form or instructions or, in the case of other submissions, by stamping the words "confidential business information" on each page containing such information. If no claim is made at the time of submission, EPA may make the information available to the public without further notice. If a claim is asserted, the information will be treated in accordance with the procedures in 40 C.F.R. Part 2 (Public Information).

b. Claims of confidentiality for the following information will be denied:

- (1) The name and address of any permit applicant or Permittee;
- (2) Permit applications, permits, and effluent data.

c. Information required by NPDES application forms provided by the Director under 40 C.F.R. § 122.21 may not be claimed confidential. This includes information submitted on the forms themselves and any attachments used to supply information required by the forms.

7. Duty to Reapply

If the Permittee wishes to continue an activity regulated by this permit after the expiration date of this permit, the Permittee must apply for and obtain a new permit. The Permittee shall submit a new application at least 180 days before the expiration date of the existing permit, unless permission for a later date has been granted by the Director. (The Director shall not grant permission for applications to be submitted later than the expiration date of the existing permit.)

8. State Authorities

Nothing in Parts 122, 123, or 124 precludes more stringent State regulation of any activity

NPDES PART II STANDARD CONDITIONS

(April 26, 2018)

covered by the regulations in 40 C.F.R. Parts 122, 123, and 124, whether or not under an approved State program.

9. Other Laws

The issuance of a permit does not authorize any injury to persons or property or invasion of other private rights, or any infringement of State or local law or regulations.

B. OPERATION AND MAINTENANCE OF POLLUTION CONTROLS

1. Proper Operation and Maintenance

The Permittee shall at all times properly operate and maintain all facilities and systems of treatment and control (and related appurtenances) which are installed or used by the Permittee to achieve compliance with the conditions of this permit. Proper operation and maintenance also includes adequate laboratory controls and appropriate quality assurance procedures. This provision requires the operation of back-up or auxiliary facilities or similar systems which are installed by a Permittee only when the operation is necessary to achieve compliance with the conditions of the permit.

2. Need to Halt or Reduce Not a Defense

It shall not be a defense for a Permittee in an enforcement action that it would have been necessary to halt or reduce the permitted activity in order to maintain compliance with the conditions of this permit.

3. Duty to Mitigate

The Permittee shall take all reasonable steps to minimize or prevent any discharge or sludge use or disposal in violation of this permit which has a reasonable likelihood of adversely affecting human health or the environment.

4. Bypass

a. Definitions

- (1) *Bypass* means the intentional diversion of waste streams from any portion of a treatment facility.
- (2) *Severe property damage* means substantial physical damage to property, damage to the treatment facilities which causes them to become inoperable, or substantial and permanent loss of natural resources which can reasonably be expected to occur in the absence of a bypass. Severe property damage does not mean economic loss caused by delays in production.

- b. *Bypass not exceeding limitations*. The Permittee may allow any bypass to occur which does not cause effluent limitations to be exceeded, but only if it also is for essential maintenance to assure efficient operation. These bypasses are not subject to the provisions of paragraphs (c) and (d) of this Section.

c. Notice

NPDES PART II STANDARD CONDITIONS

(April 26, 2018)

- (1) *Anticipated bypass.* If the Permittee knows in advance of the need for a bypass, it shall submit prior notice, if possible at least ten days before the date of the bypass. As of December 21, 2020 all notices submitted in compliance with this Section must be submitted electronically by the Permittee to the Director or initial recipient, as defined in 40 C.F.R. § 127.2(b), in compliance with this Section and 40 C.F.R. Part 3 (including, in all cases, Subpart D to Part 3), § 122.22, and 40 C.F.R. Part 127. Part 127 is not intended to undo existing requirements for electronic reporting. Prior to this date, and independent of Part 127, Permittees may be required to report electronically if specified by a particular permit or if required to do so by state law.
- (2) *Unanticipated bypass.* The Permittee shall submit notice of an unanticipated bypass as required in paragraph D.1.e. of this part (24-hour notice). As of December 21, 2020 all notices submitted in compliance with this Section must be submitted electronically by the Permittee to the Director or initial recipient, as defined in 40 C.F.R. § 127.2(b), in compliance with this Section and 40 C.F.R. Part 3 (including, in all cases, Subpart D to Part 3), § 122.22, and 40 C.F.R. Part 127. Part 127 is not intended to undo existing requirements for electronic reporting. Prior to this date, and independent of Part 127, Permittees may be required to report electronically if specified by a particular permit or required to do so by law.

d. *Prohibition of bypass.*

- (1) Bypass is prohibited, and the Director may take enforcement action against a Permittee for bypass, unless:
 - (a) Bypass was unavoidable to prevent loss of life, personal injury, or severe property damage;
 - (b) There were no feasible alternatives to the bypass, such as the use of auxiliary treatment facilities, retention of untreated wastes, or maintenance during normal periods of equipment downtime. This condition is not satisfied if adequate back-up equipment should have been installed in the exercise of reasonable engineering judgment to prevent a bypass which occurred during normal periods of equipment downtime or preventative maintenance; and
 - (c) The Permittee submitted notices as required under paragraph 4.c of this Section.
- (2) The Director may approve an anticipated bypass, after considering its adverse effects, if the Director determines that it will meet the three conditions listed above in paragraph 4.d of this Section.

5. Upset

- a. *Definition.* *Upset* means an exceptional incident in which there is an unintentional and temporary noncompliance with technology based permit effluent limitations because of factors beyond the reasonable control of the Permittee. An upset does not include noncompliance to the extent caused by operational error, improperly designed treatment facilities, inadequate treatment facilities, lack of preventive maintenance, or careless or

NPDES PART II STANDARD CONDITIONS
(April 26, 2018)

- improper operation.
- b. *Effect of an upset.* An upset constitutes an affirmative defense to an action brought for noncompliance with such technology based permit effluent limitations if the requirements of paragraph B.5.c. of this Section are met. No determination made during administrative review of claims that noncompliance was caused by upset, and before an action for noncompliance, is final administrative action subject to judicial review.
 - c. *Conditions necessary for a demonstration of upset.* A Permittee who wishes to establish the affirmative defense of upset shall demonstrate, through properly signed, contemporaneous operating logs, or other relevant evidence that:
 - (1) An upset occurred and that the Permittee can identify the cause(s) of the upset;
 - (2) The permitted facility was at the time being properly operated; and
 - (3) The Permittee submitted notice of the upset as required in paragraph D.1.e.2.b. (24-hour notice).
 - (4) The Permittee complied with any remedial measures required under B.3. above.
 - d. *Burden of proof.* In any enforcement proceeding the Permittee seeking to establish the occurrence of an upset has the burden of proof.

C. MONITORING REQUIREMENTS

1. Monitoring and Records

- a. Samples and measurements taken for the purpose of monitoring shall be representative of the monitored activity.
- b. Except for records of monitoring information required by this permit related to the Permittee's sewage sludge use and disposal activities, which shall be retained for a period of at least 5 years (or longer as required by 40 C.F.R. § 503), the Permittee shall retain records of all monitoring information, including all calibration and maintenance records and all original strip chart recordings for continuous monitoring instrumentation, copies of all reports required by this permit, and records of all data used to complete the application for this permit, for a period of at least 3 years from the date of the sample, measurement, report or application. This period may be extended by request of the Director at any time.
- c. Records of monitoring information shall include:
 - (1) The date, exact place, and time of sampling or measurements;
 - (2) The individual(s) who performed the sampling or measurements;
 - (3) The date(s) analyses were performed;
 - (4) The individual(s) who performed the analyses;
 - (5) The analytical techniques or methods used; and
 - (6) The results of such analyses.
- d. Monitoring must be conducted according to test procedures approved under 40 C.F.R. § 136 unless another method is required under 40 C.F.R. Subchapters N or O.
- e. The Clean Water Act provides that any person who falsifies, tampers with, or

NPDES PART II STANDARD CONDITIONS
(April 26, 2018)

knowingly renders inaccurate any monitoring device or method required to be maintained under this permit shall, upon conviction, be punished by a fine of not more than \$10,000, or by imprisonment for not more than 2 years, or both. If a conviction of a person is for a violation committed after a first conviction of such person under this paragraph, punishment is a fine of not more than \$20,000 per day of violation, or by imprisonment of not more than 4 years, or both.

2. Inspection and Entry

The Permittee shall allow the Director, or an authorized representative (including an authorized contractor acting as a representative of the Administrator), upon presentation of credentials and other documents as may be required by law, to:

- a. Enter upon the Permittee's premises where a regulated facility or activity is located or conducted, or where records must be kept under the conditions of this permit;
- b. Have access to and copy, at reasonable times, any records that must be kept under the conditions of this permit;
- c. Inspect at reasonable times any facilities, equipment (including monitoring and control equipment), practices, or operations regulated or required under this permit; and
- d. Sample or monitor at reasonable times, for the purposes of assuring permit compliance or as otherwise authorized by the Clean Water Act, any substances or parameters at any location.

D. REPORTING REQUIREMENTS

1. Reporting Requirements

- a. *Planned Changes*. The Permittee shall give notice to the Director as soon as possible of any planned physical alterations or additions to the permitted facility. Notice is required only when:
 - (1) The alteration or addition to a permitted facility may meet one of the criteria for determining whether a facility is a new source in 40 C.F.R. § 122.29(b); or
 - (2) The alteration or addition could significantly change the nature or increase the quantity of pollutants discharged. This notification applies to pollutants which are subject neither to effluent limitations in the permit, nor to notification requirements at 40 C.F.R. § 122.42(a)(1).
 - (3) The alteration or addition results in a significant change in the Permittee's sludge use or disposal practices, and such alteration, addition, or change may justify the application of permit conditions that are different from or absent in the existing permit, including notification of additional use or disposal sites not reported during the permit application process or not reported pursuant to an approved land application plan.
- b. *Anticipated noncompliance*. The Permittee shall give advance notice to the Director of any planned changes in the permitted facility or activity which may result in noncompliance with permit requirements.

NPDES PART II STANDARD CONDITIONS

(April 26, 2018)

- c. *Transfers.* This permit is not transferable to any person except after notice to the Director. The Director may require modification or revocation and reissuance of the permit to change the name of the Permittee and incorporate such other requirements as may be necessary under the Clean Water Act. *See* 40 C.F.R. § 122.61; in some cases, modification or revocation and reissuance is mandatory.
- d. *Monitoring reports.* Monitoring results shall be reported at the intervals specified elsewhere in this permit.
 - (1) Monitoring results must be reported on a Discharge Monitoring Report (DMR) or forms provided or specified by the Director for reporting results of monitoring of sludge use or disposal practices. As of December 21, 2016 all reports and forms submitted in compliance with this Section must be submitted electronically by the Permittee to the Director or initial recipient, as defined in 40 C.F.R. § 127.2(b), in compliance with this Section and 40 C.F.R. Part 3 (including, in all cases, Subpart D to Part 3), § 122.22, and 40 C.F.R. Part 127. Part 127 is not intended to undo existing requirements for electronic reporting. Prior to this date, and independent of Part 127, Permittees may be required to report electronically if specified by a particular permit or if required to do so by State law.
 - (2) If the Permittee monitors any pollutant more frequently than required by the permit using test procedures approved under 40 C.F.R. § 136, or another method required for an industry-specific waste stream under 40 C.F.R. Subchapters N or O, the results of such monitoring shall be included in the calculation and reporting of the data submitted in the DMR or sludge reporting form specified by the Director.
 - (3) Calculations for all limitations which require averaging or measurements shall utilize an arithmetic mean unless otherwise specified by the Director in the permit.
- e. *Twenty-four hour reporting.*
 - (1) The Permittee shall report any noncompliance which may endanger health or the environment. Any information shall be provided orally within 24 hours from the time the Permittee becomes aware of the circumstances. A written report shall also be provided within 5 days of the time the Permittee becomes aware of the circumstances. The written report shall contain a description of the noncompliance and its cause; the period of noncompliance, including exact dates and times, and if the noncompliance has not been corrected, the anticipated time it is expected to continue; and steps taken or planned to reduce, eliminate, and prevent reoccurrence of the noncompliance. For noncompliance events related to combined sewer overflows, sanitary sewer overflows, or bypass events, these reports must include the data described above (with the exception of time of discovery) as well as the type of event (combined sewer overflows, sanitary sewer overflows, or bypass events), type of sewer overflow structure (e.g., manhole, combined sewer overflow outfall), discharge volumes untreated by the treatment works treating domestic sewage, types of human health and environmental impacts of the sewer overflow event, and whether the noncompliance was related to wet weather. As of December 21, 2020 all

NPDES PART II STANDARD CONDITIONS

(April 26, 2018)

reports related to combined sewer overflows, sanitary sewer overflows, or bypass events submitted in compliance with this section must be submitted electronically by the Permittee to the Director or initial recipient, as defined in 40 C.F.R. § 127.2(b), in compliance with this Section and 40 C.F.R. Part 3 (including, in all cases Subpart D to Part 3), § 122.22, and 40 C.F.R. Part 127. Part 127 is not intended to undo existing requirements for electronic reporting. Prior to this date, and independent of Part 127, Permittees may be required to electronically submit reports related to combined sewer overflows, sanitary sewer overflows, or bypass events under this section by a particular permit or if required to do so by state law. The Director may also require Permittees to electronically submit reports not related to combined sewer overflows, sanitary sewer overflows, or bypass events under this section.

- (2) The following shall be included as information which must be reported within 24 hours under this paragraph.
 - (a) Any unanticipated bypass which exceeds any effluent limitation in the permit. *See* 40 C.F.R. § 122.41(g).
 - (b) Any upset which exceeds any effluent limitation in the permit.
 - (c) Violation of a maximum daily discharge limitation for any of the pollutants listed by the Director in the permit to be reported within 24 hours. *See* 40 C.F.R. § 122.44(g).
 - (3) The Director may waive the written report on a case-by-case basis for reports under paragraph D.1.e. of this Section if the oral report has been received within 24 hours.
- f. *Compliance Schedules.* Reports of compliance or noncompliance with, or any progress reports on, interim and final requirements contained in any compliance schedule of this permit shall be submitted no later than 14 days following each schedule date.
- g. *Other noncompliance.* The Permittee shall report all instances of noncompliance not reported under paragraphs D.1.d., D.1.e., and D.1.f. of this Section, at the time monitoring reports are submitted. The reports shall contain the information listed in paragraph D.1.e. of this Section. For noncompliance events related to combined sewer overflows, sanitary sewer overflows, or bypass events, these reports shall contain the information described in paragraph D.1.e. and the applicable required data in Appendix A to 40 C.F.R. Part 127. As of December 21, 2020 all reports related to combined sewer overflows, sanitary sewer overflows, or bypass events submitted in compliance with this section must be submitted electronically by the Permittee to the Director or initial recipient, as defined in 40 C.F.R. § 127.2(b), in compliance with this Section and 40 C.F.R. Part 3 (including, in all cases, Subpart D to Part 3), §122.22, and 40 C.F.R. Part 127. Part 127 is not intended to undo existing requirements for electronic reporting. Prior to this date, and independent of Part 127, Permittees may be required to electronically submit reports related to combined sewer overflows, sanitary sewer overflows, or bypass events under this section by a particular permit or if required to do so by state law. The Director may also require Permittees to electronically submit reports not related to combined sewer overflows, sanitary sewer overflows, or bypass events under this Section.
- h. *Other information.* Where the Permittee becomes aware that it failed to submit any

NPDES PART II STANDARD CONDITIONS

(April 26, 2018)

relevant facts in a permit application, or submitted incorrect information in a permit application or in any report to the Director, it shall promptly submit such facts or information.

- i. *Identification of the initial recipient for NPDES electronic reporting data.* The owner, operator, or the duly authorized representative of an NPDES-regulated entity is required to electronically submit the required NPDES information (as specified in Appendix A to 40 C.F.R. Part 127) to the appropriate initial recipient, as determined by EPA, and as defined in 40 C.F.R. § 127.2(b). EPA will identify and publish the list of initial recipients on its Web site and in the FEDERAL REGISTER, by state and by NPDES data group (see 40 C.F.R. § 127.2(c) of this Chapter). EPA will update and maintain this listing.

2. Signatory Requirement

- a. All applications, reports, or information submitted to the Director shall be signed and certified. *See* 40 C.F.R. §122.22.
- b. The CWA provides that any person who knowingly makes any false statement, representation, or certification in any record or other document submitted or required to be maintained under this permit, including monitoring reports or reports of compliance or non-compliance shall, upon conviction, be punished by a fine of not more than \$10,000 per violation, or by imprisonment for not more than 6 months per violation, or by both.

3. Availability of Reports.

Except for data determined to be confidential under paragraph A.6. above, all reports prepared in accordance with the terms of this permit shall be available for public inspection at the offices of the State water pollution control agency and the Director. As required by the CWA, effluent data shall not be considered confidential. Knowingly making any false statements on any such report may result in the imposition of criminal penalties as provided for in Section 309 of the CWA.

E. DEFINITIONS AND ABBREVIATIONS

1. General Definitions

For more definitions related to sludge use and disposal requirements, see EPA Region 1's NPDES Permit Sludge Compliance Guidance document (4 November 1999, modified to add regulatory definitions, April 2018).

Administrator means the Administrator of the United States Environmental Protection Agency, or an authorized representative.

Applicable standards and limitations means all, State, interstate, and federal standards and limitations to which a "discharge," a "sewage sludge use or disposal practice," or a related activity is subject under the CWA, including "effluent limitations," water quality standards, standards of performance, toxic effluent standards or prohibitions, "best management practices," pretreatment standards, and "standards for sewage sludge use or disposal" under Sections 301, 302, 303, 304, 306, 307, 308, 403 and 405 of the CWA.

Application means the EPA standard national forms for applying for a permit, including any additions, revisions, or modifications to the forms; or forms approved by EPA for use in

NPDES PART II STANDARD CONDITIONS
(April 26, 2018)

“approved States,” including any approved modifications or revisions.

Approved program or *approved State* means a State or interstate program which has been approved or authorized by EPA under Part 123.

Average monthly discharge limitation means the highest allowable average of “daily discharges” over a calendar month, calculated as the sum of all “daily discharges” measured during a calendar month divided by the number of “daily discharges” measured during that month.

Average weekly discharge limitation means the highest allowable average of “daily discharges” over a calendar week, calculated as the sum of all “daily discharges” measured during a calendar week divided by the number of “daily discharges” measured during that week.

Best Management Practices (“BMPs”) means schedules of activities, prohibitions of practices, maintenance procedures, and other management practices to prevent or reduce the pollution of “waters of the United States.” BMPs also include treatment requirements, operating procedures, and practices to control plant site runoff, spillage or leaks, sludge or waste disposal, or drainage from raw material storage.

Bypass see B.4.a.1 above.

C-NOEC or “*Chronic (Long-term Exposure Test) – No Observed Effect Concentration*” means the highest tested concentration of an effluent or a toxicant at which no adverse effects are observed on the aquatic test organisms at a specified time of observation.

Class I sludge management facility is any publicly owned treatment works (POTW), as defined in 40 C.F.R. § 501.2, required to have an approved pretreatment program under 40 C.F.R. § 403.8 (a) (including any POTW located in a State that has elected to assume local program responsibilities pursuant to 40 C.F.R. § 403.10 (e)) and any treatment works treating domestic sewage, as defined in 40 C.F.R. § 122.2, classified as a Class I sludge management facility by the EPA Regional Administrator, or, in the case of approved State programs, the Regional Administrator in conjunction with the State Director, because of the potential for its sewage sludge use or disposal practice to affect public health and the environment adversely.

Contiguous zone means the entire zone established by the United States under Article 24 of the Convention on the Territorial Sea and the Contiguous Zone.

Continuous discharge means a “discharge” which occurs without interruption throughout the operating hours of the facility, except for infrequent shutdowns for maintenance, process changes, or similar activities.

CWA means the Clean Water Act (formerly referred to as the Federal Water Pollution Control Act or Federal Water Pollution Control Act Amendments of 1972) Public Law 92-500, as amended by Public Law 95-217, Public Law 95-576, Public Law 96-483 and Public Law 97-117, 33 U.S.C. 1251 *et seq.*

CWA and regulations means the Clean Water Act (CWA) and applicable regulations promulgated thereunder. In the case of an approved State program, it includes State program requirements.

Daily Discharge means the “discharge of a pollutant” measured during a calendar day or any

NPDES PART II STANDARD CONDITIONS
(April 26, 2018)

other 24-hour period that reasonably represents the calendar day for purposes of sampling. For pollutants with limitations expressed in units of mass, the “daily discharge” is calculated as the total mass of the pollutant discharged over the day. For pollutants with limitations expressed in other units of measurements, the “daily discharge” is calculated as the average measurement of the pollutant over the day.

Direct Discharge means the “discharge of a pollutant.”

Director means the Regional Administrator or an authorized representative. In the case of a permit also issued under Massachusetts’ authority, it also refers to the Director of the Division of Watershed Management, Department of Environmental Protection, Commonwealth of Massachusetts.

Discharge

- (a) When used without qualification, *discharge* means the “discharge of a pollutant.”
- (b) As used in the definitions for “interference” and “pass through,” *discharge* means the introduction of pollutants into a POTW from any non-domestic source regulated under Section 307(b), (c) or (d) of the Act.

Discharge Monitoring Report (“DMR”) means the EPA uniform national form, including any subsequent additions, revisions, or modifications for the reporting of self-monitoring results by Permittees. DMRs must be used by “approved States” as well as by EPA. EPA will supply DMRs to any approved State upon request. The EPA national forms may be modified to substitute the State Agency name, address, logo, and other similar information, as appropriate, in place of EPA’s.

Discharge of a pollutant means:

- (a) Any addition of any “pollutant” or combination of pollutants to “waters of the United States” from any “point source,” or
- (b) Any addition of any pollutant or combination of pollutants to the waters of the “contiguous zone” or the ocean from any point source other than a vessel or other floating craft which is being used as a means of transportation.

This definition includes additions of pollutants into waters of the United States from: surface runoff which is collected or channeled by man; discharges through pipes, sewers, or other conveyances owned by a State, municipality, or other person which do not lead to a treatment works; and discharges through pipes, sewers, or other conveyances, leading into privately owned treatment works. This term does not include an addition of pollutants by any “indirect discharger.”

Effluent limitation means any restriction imposed by the Director on quantities, discharge rates, and concentrations of “pollutants” which are “discharged” from “point sources” into “waters of the United States,” the waters of the “contiguous zone,” or the ocean.

Effluent limitation guidelines means a regulation published by the Administrator under section 304(b) of CWA to adopt or revise “effluent limitations.”

Environmental Protection Agency (“EPA”) means the United States Environmental Protection

NPDES PART II STANDARD CONDITIONS
(April 26, 2018)

Agency.

Grab Sample means an individual sample collected in a period of less than 15 minutes.

Hazardous substance means any substance designated under 40 C.F.R. Part 116 pursuant to Section 311 of CWA.

Incineration is the combustion of organic matter and inorganic matter in sewage sludge by high temperatures in an enclosed device.

Indirect discharger means a nondomestic discharger introducing “pollutants” to a “publicly owned treatment works.”

Interference means a discharge (see definition above) which, alone or in conjunction with a discharge or discharges from other sources, both:

- (a) Inhibits or disrupts the POTW, its treatment processes or operations, or its sludge processes, use or disposal; and
- (b) Therefore is a cause of a violation of any requirement of the POTW’s NPDES permit (including an increase in the magnitude or duration of a violation) or of the prevention of sewage sludge use or disposal in compliance with the following statutory provisions and regulations or permits issued thereunder (or more stringent State or local regulations): Section 405 of the Clean Water Act, the Solid Waste Disposal Act (SWDA) (including title II, more commonly referred to as the Resources Conservation and Recovery Act (RCRA), and including State regulations contained in any State sludge management plan prepared pursuant to Subtitle D of the SDWA), the Clean Air Act, the Toxic Substances Control Act, and the Marine Protection, Research and Sanctuaries Act.

Landfill means an area of land or an excavation in which wastes are placed for permanent disposal, and that is not a land application unit, surface impoundment, injection well, or waste pile.

Land application is the spraying or spreading of sewage sludge onto the land surface; the injection of sewage sludge below the land surface; or the incorporation of sewage sludge into the soil so that the sewage sludge can either condition the soil or fertilize crops or vegetation grown in the soil.

Land application unit means an area where wastes are applied onto or incorporated into the soil surface (excluding manure spreading operations) for agricultural purposes or for treatment and disposal.

LC₅₀ means the concentration of a sample that causes mortality of 50% of the test population at a specific time of observation. The LC₅₀ = 100% is defined as a sample of undiluted effluent.

Maximum daily discharge limitation means the highest allowable “daily discharge.”

Municipal solid waste landfill (MSWLF) unit means a discrete area of land or an excavation that receives household waste, and that is not a land application unit, surface impoundment, injection well, or waste pile, as those terms are defined under 40 C.F.R. § 257.2. A MSWLF unit also may receive other types of RCRA Subtitle D wastes, such as commercial solid waste, nonhazardous sludge, very small quantity generator waste and industrial solid waste. Such a landfill may be

NPDES PART II STANDARD CONDITIONS
(April 26, 2018)

publicly or privately owned. A MSWLF unit may be a new MSWLF unit, an existing MSWLF unit or a lateral expansion. A construction and demolition landfill that receives residential lead-based paint waste and does not receive any other household waste is not a MSWLF unit.

Municipality

- (a) When used without qualification *municipality* means a city, town, borough, county, parish, district, association, or other public body created by or under State law and having jurisdiction over disposal of sewage, industrial wastes, or other wastes, or an Indian tribe or an authorized Indian tribal organization, or a designated and approved management agency under Section 208 of CWA.
- (b) As related to sludge use and disposal, *municipality* means a city, town, borough, county, parish, district, association, or other public body (including an intermunicipal Agency of two or more of the foregoing entities) created by or under State law; an Indian tribe or an authorized Indian tribal organization having jurisdiction over sewage sludge management; or a designated and approved management Agency under Section 208 of the CWA, as amended. The definition includes a special district created under State law, such as a water district, sewer district, sanitary district, utility district, drainage district, or similar entity, or an integrated waste management facility as defined in Section 201 (e) of the CWA, as amended, that has as one of its principal responsibilities the treatment, transport, use or disposal of sewage sludge.

National Pollutant Discharge Elimination System means the national program for issuing, modifying, revoking and reissuing, terminating, monitoring and enforcing permits, and imposing and enforcing pretreatment requirements, under Sections 307, 402, 318, and 405 of the CWA. The term includes an “approved program.”

New Discharger means any building, structure, facility, or installation:

- (a) From which there is or may be a “discharge of pollutants;”
- (b) That did not commence the “discharge of pollutants” at a particular “site” prior to August 13, 1979;
- (c) Which is not a “new source;” and
- (d) Which has never received a finally effective NPDES permit for discharges at that “site.”

This definition includes an “indirect discharger” which commences discharging into “waters of the United States” after August 13, 1979. It also includes any existing mobile point source (other than an offshore or coastal oil and gas exploratory drilling rig or a coastal oil and gas exploratory drilling rig or a coastal oil and gas exploratory drilling rig or a coastal oil and gas developmental drilling rig) such as a seafood processing rig, seafood processing vessel, or aggregate plant, that begins discharging at a “site” for which it does not have a permit; and any offshore or coastal mobile oil and gas exploratory drilling rig or coastal mobile oil and gas developmental drilling rig that commences the discharge of pollutants after August 13, 1979, at a “site” under EPA’s permitting jurisdiction for which it is not covered by an individual or general permit and which is located in an area determined by the Director in the issuance of a final permit to be in an area of biological concern. In determining whether an area is an area of biological concern, the Director shall consider the factors specified in 40 C.F.R. §§ 125.122 (a) (1) through (10).

NPDES PART II STANDARD CONDITIONS

(April 26, 2018)

An offshore or coastal mobile exploratory drilling rig or coastal mobile developmental drilling rig will be considered a “new discharger” only for the duration of its discharge in an area of biological concern.

New source means any building, structure, facility, or installation from which there is or may be a “discharge of pollutants,” the construction of which commenced:

- (a) After promulgation of standards of performance under Section 306 of CWA which are applicable to such source, or
- (b) After proposal of standards of performance in accordance with Section 306 of CWA which are applicable to such source, but only if the standards are promulgated in accordance with Section 306 within 120 days of their proposal.

NPDES means “National Pollutant Discharge Elimination System.”

Owner or operator means the owner or operator of any “facility or activity” subject to regulation under the NPDES programs.

Pass through means a Discharge (see definition above) which exits the POTW into waters of the United States in quantities or concentrations which, alone or in conjunction with a discharge or discharges from other sources, is a cause of a violation of any requirement of the POTW’s NPDES permit (including an increase in the magnitude or duration of a violation).

Pathogenic organisms are disease-causing organisms. These include, but are not limited to, certain bacteria, protozoa, viruses, and viable helminth ova.

Permit means an authorization, license, or equivalent control document issued by EPA or an “approved State” to implement the requirements of Parts 122, 123, and 124. “Permit” includes an NPDES “general permit” (40 C.F.R § 122.28). “Permit” does not include any permit which has not yet been the subject of final agency action, such as a “draft permit” or “proposed permit.”

Person means an individual, association, partnership, corporation, municipality, State or Federal agency, or an agent or employee thereof.

Person who prepares sewage sludge is either the person who generates sewage sludge during the treatment of domestic sewage in a treatment works or the person who derives a material from sewage sludge.

pH means the logarithm of the reciprocal of the hydrogen ion concentration measured at 25° Centigrade or measured at another temperature and then converted to an equivalent value at 25° Centigrade.

Point Source means any discernible, confined, and discrete conveyance, including but not limited to, any pipe, ditch, channel, tunnel, conduit, well, discrete fissure, container, rolling stock, concentrated animal feeding operation, landfill leachate collection system, vessel or other floating craft from which pollutants are or may be discharged. This term does not include return flows from irrigated agriculture or agricultural storm water runoff (see 40 C.F.R. § 122.3).

Pollutant means dredged spoil, solid waste, incinerator residue, filter backwash, sewage, garbage, sewage sludge, munitions, chemical wastes, biological materials, radioactive materials

NPDES PART II STANDARD CONDITIONS

(April 26, 2018)

(except those regulated under the Atomic Energy Act of 1954, as amended (42 U.S.C. 2011 *et seq.*)), heat, wrecked or discarded equipment, rock, sand, cellar dirt and industrial, municipal, and agricultural waste discharged into water. It does not mean:

- (a) Sewage from vessels; or
- (b) Water, gas, or other material which is injected into a well to facilitate production of oil or gas, or water derived in association with oil and gas production and disposed of in a well, if the well is used either to facilitate production or for disposal purposes is approved by the authority of the State in which the well is located, and if the State determines that the injection or disposal will not result in the degradation of ground or surface water resources.

Primary industry category means any industry category listed in the NRDC settlement agreement (*Natural Resources Defense Council et al. v. Train*, 8 E.R.C. 2120 (D.D.C. 1976), *modified* 12 E.R.C. 1833 (D.D.C. 1979)); also listed in Appendix A of 40 C.F.R. Part 122.

Privately owned treatment works means any device or system which is (a) used to treat wastes from any facility whose operator is not the operator of the treatment works and (b) not a “POTW.”

Process wastewater means any water which, during manufacturing or processing, comes into direct contact with or results from the production or use of any raw material, intermediate product, finished product, byproduct, or waste product.

Publicly owned treatment works (POTW) means a treatment works as defined by Section 212 of the Act, which is owned by a State or municipality (as defined by Section 504(4) of the Act). This definition includes any devices and systems used in the storage, treatment, recycling and reclamation of municipal sewage or industrial wastes of a liquid nature. It also includes sewers, pipes and other conveyances only if they convey wastewater to a POTW Treatment Plant. The term also means the municipality as defined in Section 502(4) of the Act, which has jurisdiction over the indirect discharges to and the discharges from such a treatment works.

Regional Administrator means the Regional Administrator, EPA, Region I, Boston, Massachusetts.

Secondary industry category means any industry which is not a “primary industry category.”

Septage means the liquid and solid material pumped from a septic tank, cesspool, or similar domestic sewage treatment system, or a holding tank when the system is cleaned or maintained.

Sewage Sludge means any solid, semi-solid, or liquid residue removed during the treatment of municipal waste water or domestic sewage. Sewage sludge includes, but is not limited to, solids removed during primary, secondary, or advanced waste water treatment, scum, septage, portable toilet pumpings, type III marine sanitation device pumpings (33 C.F.R. Part 159), and sewage sludge products. Sewage sludge does not include grit or screenings, or ash generated during the incineration of sewage sludge.

Sewage sludge incinerator is an enclosed device in which only sewage sludge and auxiliary fuel are fired.

Sewage sludge unit is land on which only sewage sludge is placed for final disposal. This does

NPDES PART II STANDARD CONDITIONS

(April 26, 2018)

not include land on which sewage sludge is either stored or treated. Land does not include waters of the United States, as defined in 40 C.F.R. § 122.2.

Sewage sludge use or disposal practice means the collection, storage, treatment, transportation, processing, monitoring, use, or disposal of sewage sludge.

Significant materials includes, but is not limited to: raw materials; fuels; materials such as solvents, detergents, and plastic pellets; finished materials such as metallic products; raw materials used in food processing or production; hazardous substance designated under Section 101(14) of CERCLA; any chemical the facility is required to report pursuant to Section 313 of title III of SARA; fertilizers; pesticides; and waste products such as ashes, slag and sludge that have the potential to be released with storm water discharges.

Significant spills includes, but is not limited to, releases of oil or hazardous substances in excess of reportable quantities under Section 311 of the CWA (see 40 C.F.R. §§ 110.10 and 117.21) or Section 102 of CERCLA (see 40 C.F.R. § 302.4).

Sludge-only facility means any “treatment works treating domestic sewage” whose methods of sewage sludge use or disposal are subject to regulations promulgated pursuant to section 405(d) of the CWA, and is required to obtain a permit under 40 C.F.R. § 122.1(b)(2).

State means any of the 50 States, the District of Columbia, Guam, the Commonwealth of Puerto Rico, the Virgin Islands, American Samoa, the Commonwealth of the Northern Mariana Islands, the Trust Territory of the Pacific Islands, or an Indian Tribe as defined in the regulations which meets the requirements of 40 C.F.R. § 123.31.

Store or storage of sewage sludge is the placement of sewage sludge on land on which the sewage sludge remains for two years or less. This does not include the placement of sewage sludge on land for treatment.

Storm water means storm water runoff, snow melt runoff, and surface runoff and drainage.

Storm water discharge associated with industrial activity means the discharge from any conveyance that is used for collecting and conveying storm water and that is directly related to manufacturing, processing, or raw materials storage areas at an industrial plant.

Surface disposal site is an area of land that contains one or more active sewage sludge units.

Toxic pollutant means any pollutant listed as toxic under Section 307(a)(1) or, in the case of “sludge use or disposal practices,” any pollutant identified in regulations implementing Section 405(d) of the CWA.

Treatment works treating domestic sewage means a POTW or any other sewage sludge or waste water treatment devices or systems, regardless of ownership (including federal facilities), used in the storage, treatment, recycling, and reclamation of municipal or domestic sewage, including land dedicated for the disposal of sewage sludge. This definition does not include septic tanks or similar devices.

For purposes of this definition, “domestic sewage” includes waste and waste water from humans or household operations that are discharged to or otherwise enter a treatment works. In States where there is no approved State sludge management program under Section 405(f) of the CWA, the Director may designate any person subject to the standards for sewage sludge use and

NPDES PART II STANDARD CONDITIONS
(April 26, 2018)

disposal in 40 C.F.R. Part 503 as a “treatment works treating domestic sewage,” where he or she finds that there is a potential for adverse effects on public health and the environment from poor sludge quality or poor sludge handling, use or disposal practices, or where he or she finds that such designation is necessary to ensure that such person is in compliance with 40 C.F.R. Part 503.

Upset see B.5.a. above.

Vector attraction is the characteristic of sewage sludge that attracts rodents, flies, mosquitoes, or other organisms capable of transporting infectious agents.

Waste pile or pile means any non-containerized accumulation of solid, non-flowing waste that is used for treatment or storage.

Waters of the United States or waters of the U.S. means:

- (a) All waters which are currently used, were used in the past, or may be susceptible to use in interstate or foreign commerce, including all waters which are subject to the ebb and flow of the tide;
- (b) All interstate waters, including interstate “wetlands;”
- (c) All other waters such as intrastate lakes, rivers, streams (including intermittent streams), mudflats, sandflats, “wetlands”, sloughs, prairie potholes, wet meadows, playa lakes, or natural ponds the use, degradation, or destruction of which would affect or could affect interstate or foreign commerce including any such waters:
 - (1) Which are or could be used by interstate or foreign travelers for recreational or other purpose;
 - (2) From which fish or shellfish are or could be taken and sold in interstate or foreign commerce; or
 - (3) Which are used or could be used for industrial purposes by industries in interstate commerce;
- (d) All impoundments of waters otherwise defined as waters of the United States under this definition;
- (e) Tributaries of waters identified in paragraphs (a) through (d) of this definition;
- (f) The territorial sea; and
- (g) “Wetlands” adjacent to waters (other than waters that are themselves wetlands) identified in paragraphs (a) through (f) of this definition.

Waste treatment systems, including treatment ponds or lagoons designed to meet the requirements of CWA (other than cooling ponds as defined in 40 C.F.R. § 423.11(m) which also meet the criteria of this definition) are not waters of the United States. This exclusion applies only to manmade bodies of water which neither were originally created in waters of the United States (such as disposal area in wetlands) nor resulted from the impoundment of waters of the United States. Waters of the United States do not include prior converted cropland.

NPDES PART II STANDARD CONDITIONS
(April 26, 2018)

Notwithstanding the determination of an area's status as prior converted cropland by any other federal agency, for the purposes of the Clean Water Act, the final authority regarding Clean Water Act jurisdiction remains with EPA.

Wetlands means those areas that are inundated or saturated by surface or groundwater at a frequency and duration sufficient to support, and that under normal circumstances do support, a prevalence of vegetation typically adapted for life in saturated soil conditions. Wetlands generally include swamps, marshes, bogs, and similar areas.

Whole Effluent Toxicity (WET) means the aggregate toxic effect of an effluent measured directly by a toxicity test.

Zone of Initial Dilution (ZID) means the region of initial mixing surrounding or adjacent to the end of the outfall pipe or diffuser ports, provided that the ZID may not be larger than allowed by mixing zone restrictions in applicable water quality standards.

2. Commonly Used Abbreviations

BOD	Five-day biochemical oxygen demand unless otherwise specified
CBOD	Carbonaceous BOD
CFS	Cubic feet per second
COD	Chemical oxygen demand
Chlorine	
Cl ₂	Total residual chlorine
TRC	Total residual chlorine which is a combination of free available chlorine (FAC, see below) and combined chlorine (chloramines, etc.)
TRO	Total residual chlorine in marine waters where halogen compounds are present
FAC	Free available chlorine (aqueous molecular chlorine, hypochlorous acid, and hypochlorite ion)
Coliform	
Coliform, Fecal	Total fecal coliform bacteria
Coliform, Total	Total coliform bacteria
Cont.	Continuous recording of the parameter being monitored, i.e. flow, temperature, pH, etc.
Cu. M/day or M ³ /day	Cubic meters per day
DO	Dissolved oxygen

NPDES PART II STANDARD CONDITIONS
(April 26, 2018)

kg/day	Kilograms per day
lbs/day	Pounds per day
mg/L	Milligram(s) per liter
mL/L	Milliliters per liter
MGD	Million gallons per day
Nitrogen	
Total N	Total nitrogen
NH ₃ -N	Ammonia nitrogen as nitrogen
NO ₃ -N	Nitrate as nitrogen
NO ₂ -N	Nitrite as nitrogen
NO ₃ -NO ₂	Combined nitrate and nitrite nitrogen as nitrogen
TKN	Total Kjeldahl nitrogen as nitrogen
Oil & Grease	Freon extractable material
PCB	Polychlorinated biphenyl
Surfactant	Surface-active agent
Temp. °C	Temperature in degrees Centigrade
Temp. °F	Temperature in degrees Fahrenheit
TOC	Total organic carbon
Total P	Total phosphorus
TSS or NFR	Total suspended solids or total nonfilterable residue
Turb. or Turbidity	Turbidity measured by the Nephelometric Method (NTU)
µg/L	Microgram(s) per liter
WET	“Whole effluent toxicity”
ZID	Zone of Initial Dilution

**UNITED STATES ENVIRONMENTAL PROTECTION AGENCY
NEW ENGLAND - REGION 1
5 POST OFFICE SQUARE, SUITE 100
BOSTON, MASSACHUSETTS 02109-3912**

FACT SHEET

**DRAFT NATIONAL POLLUTANT DISCHARGE ELIMINATION SYSTEM (NPDES)
PERMIT TO DISCHARGE TO WATERS OF THE UNITED STATES PURSUANT TO
THE CLEAN WATER ACT (CWA)**

NPDES PERMIT NUMBER: MA0100935

PUBLIC NOTICE START AND END DATES: June 21 – July 22, 2019

NAME AND MAILING ADDRESS OF APPLICANT:

Town of Lenox
Department of Public Works
275 Main Street
Lenox, MA 01240

NAME AND ADDRESS OF FACILITY WHERE DISCHARGE OCCURS:

Lenox Wastewater Treatment Plant
239 Crystal Street
Lenox Dale, MA 01242

RECEIVING WATER AND CLASSIFICATION:

Housatonic River (MA21-19)
Connecticut River Watershed - USGS Code: 0100005
Class B - Warm Water Fishery

TABLE OF CONTENTS

1	Proposed Action.....	4
2	Statutory and Regulatory Authority.....	4
2.1	Technology-Based Requirements.....	4
2.2	Water Quality Based Requirements.....	5
2.2.1	Water Quality Standards.....	5
2.2.2	Anti-degradation.....	5
2.2.3	Assessment and Listing of Waters and Total Maximum Daily Loads.....	6
2.2.4	Reasonable Potential.....	6
2.2.5	State Certification.....	7
2.3	Effluent Flow Requirements.....	8
2.4	Monitoring and Reporting Requirements.....	9
2.4.1	Monitoring Requirements.....	9
2.4.2	Reporting Requirements.....	10
2.5	Anti-backsliding.....	11
3	Location and Type of Facility.....	11
3.1.1	Treatment Process Description.....	12
3.1.2	Collection System Description.....	12
4	Description of Receiving Water and Dilution.....	12
4.1	Available Dilution.....	13
5	Proposed Effluent Limitations and Conditions.....	14
5.1	Effluent Limitations and Monitoring Requirements.....	14
5.1.1	Wastewater Effluent Flow.....	14
5.1.2	Biochemical Oxygen Demand (BOD ₅).....	15
5.1.3	Total Suspended Solids (TSS).....	16
5.1.4	Eighty-Five Percent (85%) BOD ₅ and TSS Removal Requirement.....	16
5.1.5	pH.....	17
5.1.6	Bacteria.....	17
5.1.7	Total Residual Chlorine.....	17
5.1.8	Ammonia.....	18
5.1.9	Nutrients.....	19
5.1.10	Metals.....	27
5.1.11	Whole Effluent Toxicity.....	31
5.2	Industrial Pretreatment Program.....	32
5.3	Sludge Conditions.....	32
5.4	Infiltration/Inflow (I/I).....	32
5.5	Operation and Maintenance of the Sewer System.....	33
5.6	Standard Conditions.....	33
6	Federal Permitting Requirements.....	33
6.1	Endangered Species Act.....	33
6.2	Essential Fish Habitat.....	34
7	Public Comments, Hearing Requests and Permit Appeals.....	35
8	EPA Contact.....	36

TABLE OF TABLES

Table 1: Limits in 1981 MA DEQE Wasteload Allocation.....	13
Table 2: Estimated Out-of-Basin Point Source Nitrogen Loadings to the Connecticut, Housatonic and Thames Rivers Watersheds.....	20
Table 3 - Annual Average Total Nitrogen Limits for Massachusetts WWTP Dischargers to the Long Island Sound Watershed.....	22
Table 4: Housatonic River Instream Total Phosphorus Concentrations (mg/L).....	25

LIST OF FIGURES

Figure 1: Lenox WWTP Location Map	(attached)
Figure 2: Lenox WWTP Process Flow Schematic	(attached)

APPENDICES

Appendix A – Discharge Monitoring Report Summary
Appendix B – Metals Reasonable Potential and Limits Calculations

1 Proposed Action

The above-named applicant (the “Permittee”) has applied to the U.S. Environmental Protection Agency (EPA) and the Massachusetts Department of Environmental Protection (MassDEP) for reissuance of a National Pollutant Discharge Elimination System (NPDES) permit to discharge from the Treatment Plant (the “Facility”) into the designated receiving water.

The permit currently in effect was issued on September 12, 2007 with an effective date of November 1, 2007 and expired on October 31, 2012 (the “2007 Permit”). The Permittee filed an application for permit reissuance with EPA dated May 3, 2012, as required by 40 Code of Federal Regulations (C.F.R.) § 122.6. Since the permit application was deemed timely and complete by EPA on May 31, 2012, the Facility’s 2007 Permit has been administratively continued pursuant to 40 C.F.R. § 122.6 and § 122.21(d). EPA and the State conducted a site visit on February 27, 2019.

This NPDES Permit is issued jointly by EPA and MassDEP under federal and state law, respectively. As such, all the terms and conditions of the permit are, therefore, incorporated into and constitute a discharge permit issued by the Director of the Division of Watershed Management pursuant to M.G.L. Chap. 21, § 43.

2 Statutory and Regulatory Authority

Congress enacted the Clean Water Act (CWA), “to restore and maintain the chemical, physical, and biological integrity of the Nation’s waters.” *See* CWA § 101(a). To achieve this objective, the CWA makes it unlawful for any person to discharge any pollutant into the waters of the United States from any point source, except as authorized by specific permitting sections of the CWA, one of which is § 402. *See* CWA §§ 303(a), 402(a). Section 402(a) established one of the CWA’s principal permitting programs, the NPDES Permit Program. Under this section, EPA may “issue a permit for the discharge of any pollutant or combination of pollutants” in accordance with certain conditions. *See* CWA § 402(a). NPDES permits generally contain discharge limitations and establish related monitoring and reporting requirements. *See* CWA § 402(a)(1) and (2). The regulations governing EPA’s NPDES permit program are generally found in 40 C.F.R. §§ 122, 124, 125, and 136.

Section 301 of the CWA provides for two types of effluent limitations to be included in NPDES permits: “technology-based” effluent limitations (TBELs) and “water quality-based” effluent limitations (WQBELs). *See* CWA §§ 301, 304(b); 40 C.F.R. §§ 122, 125, and 131.

2.1 Technology-Based Requirements

Technology-based limitations, generally developed on an industry-by-industry basis, reflect a specified level of pollutant reducing technology available and economically achievable for the type of facility being permitted. *See* CWA § 301(b). As a class, publicly owned treatment works (POTWs) must meet performance-based requirements based on available wastewater treatment technology. *See* CWA § 301(b)(1)(D). The performance level for POTWs is referred to as “secondary treatment.” Secondary treatment is comprised of technology-based requirements expressed in terms of BOD₅, TSS and pH. *See* 40 C.F.R. § 133.

Under § 301(b)(1) of the CWA, POTWs must have achieved effluent limits based upon secondary treatment technology by July 1, 1977. Since all statutory deadlines for meeting various treatment technology-based effluent limitations established pursuant to the CWA have expired, when technology-based effluent limits are included in a permit, compliance with those limitations is from the date the issued permit becomes effective. *See* 40 C.F.R. § 125.3(a)(1).

2.2 Water Quality Based Requirements

The CWA and federal regulations require that effluent limitations based on water quality considerations be established for point source discharges when such limitations are necessary to meet state or federal water quality standards that are applicable to the designated receiving water. This is necessary when less stringent TBELs would interfere with the attainment or maintenance of water quality criteria in the receiving water. *See* § 301(b)(1)(C) of the CWA and 40 C.F.R. §§ 122.44(d)(1) and 122.44(d)(5).

2.2.1 Water Quality Standards

The CWA requires that each state develop water quality standards (WQSs) for all water bodies within the State. *See* CWA § 303 and 40 C.F.R. § 131.10-12. Generally, WQSs consist of three parts: 1) beneficial designated use or uses for a water-body or a segment of a water-body; 2) numeric or narrative water quality criteria sufficient to protect the assigned designated use(s); and 3) anti-degradation requirements to ensure that once a use is attained it will not be degraded and to protect high quality and National resource waters. *See* CWA § 303(c)(2)(A) and 40 C.F.R. § 131.12. The applicable State WQSs can be found in Title 314 of the Code of Massachusetts Regulations, Chapter 4 (314 CMR 4.00).

Receiving water requirements are established according to numerical and narrative standards in WQSs adopted under State law for each water body classification. When using chemical-specific numeric criteria to develop permit limits, acute and chronic aquatic life criteria and human health criteria are used and expressed in terms of maximum allowable in-stream pollutant concentrations. In general, aquatic-life acute criteria are considered applicable to daily time periods (maximum daily limit) and aquatic-life chronic criteria are considered applicable to monthly time periods (average monthly limit). Chemical-specific human health criteria are typically based on lifetime chronic exposure and are therefore typically applicable to monthly average limits.

When permit effluent limits are necessary for a pollutant to meet narrative water quality criteria, the permitting authority must establish effluent limits in one of three ways: based on a “calculated numeric criterion for the pollutant which the permitting authority demonstrates will attain and maintain applicable narrative water quality criteria and fully protect the designated use,” on a “case-by-case basis” using CWA § 304(a) recommended water quality criteria, supplemented as necessary by other relevant information; or, in certain circumstances, based on an indicator parameter. *See* 40 C.F.R. § 122.44(d)(1)(vi)(A-C).

2.2.2 Anti-degradation

Federal regulations found at 40 C.F.R. § 131.12 require states to develop and adopt a statewide anti-degradation policy that maintains and protects existing in-stream water uses and the level of

water quality necessary to protect these existing uses. In addition, the anti-degradation policy ensures that high quality waters which exceed levels necessary to support propagation of fish, shellfish, and wildlife and support recreation in and on the water, are maintained unless the State finds that allowing degradation is necessary to accommodate important economic or social development in the area in which the waters are located.

Massachusetts' statewide anti-degradation policy, entitled "Antidegradation Provisions", is found in the State's WQSs at 314 CMR 4.04. Massachusetts guidance for the implementation of this policy is in an associated document entitled "Implementation Procedure for the Anti-degradation Provisions of the State Water Quality Standards", dated October 21, 2009. According to the policy, no lowering of water quality is allowed, except in accordance with the anti-degradation policy, and all existing in-stream uses and the level of water quality necessary to protect the existing uses of a receiving water must be maintained and protected.

This permit is being reissued with effluent limitations sufficiently stringent to protect the existing uses of the receiving water.

2.2.3 Assessment and Listing of Waters and Total Maximum Daily Loads.

The objective of the CWA is to restore and maintain the chemical, physical and biological integrity of the Nation's waters. To meet this goal, the CWA requires states to develop information on the quality of their water resources and report this information to EPA, the U.S. Congress, and the public. To this end, the EPA released guidance on November 19, 2001, for the preparation of an integrated "List of Waters" that could combine reporting elements of both § 305(b) and § 303(d) of the CWA. The integrated list format allows states to provide the status of all their assessed waters in one list. States choosing this option must list each water body or segment in one of the following five categories: 1) Unimpaired and not threatened for all designated uses; 2) Unimpaired waters for some uses and not assessed for others; 3) Insufficient information to make assessments for any uses; 4) Impaired or threatened for one or more uses but not requiring the calculation of a Total Maximum Daily Load (TMDL); and 5) Impaired or threatened for one or more uses and requiring a TMDL.

A TMDL is a planning tool and potential starting point for restoration activities with the ultimate goal of attaining water quality standards. A TMDL is essentially a pollution budget designed to restore the health of an impaired water body. A TMDL typically identifies the source(s) of the pollutant from direct and indirect discharges, determines the maximum load of the pollutant that can be discharged to a specific water body while maintaining WQSs for designated uses, and allocates that load to the various pollutant sources, including point source discharges, subject to NPDES permits. *See* 40 C.F.R. § 130.7.

For impaired waters where a TMDL has been developed for a particular pollutant and the TMDL includes a waste load allocation for a NPDES permitted discharge, the effluent limit in the permit may not exceed the waste load allocation. *See* 40 C.F.R. § 122.44(d)(1)(vii)(B).

2.2.4 Reasonable Potential

Pursuant to 40 C.F.R. § 122.44(d)(1), NPDES permits must contain any requirements in addition to TBELs necessary to achieve water quality standards established under § 303 of the CWA. In

addition, limitations “must control any pollutant or pollutant parameter (conventional, non-conventional, or toxic) which the Director determines are or may be discharged at a level which will cause, have the reasonable potential to cause, or contribute to an excursion above any water quality standard, including State narrative criteria for water quality”. *See* 40 C.F.R.

§ 122.44(d)(1)(i). There is reasonable potential to cause or contribute to an excursion if the projected or actual in-stream concentration exceeds the applicable criterion. If the permitting authority determines that a discharge causes, has the reasonable potential to cause, or contributes to such an excursion, the permit must contain WQBELs for the pollutant. *See* 40 C.F.R.

§ 122.44(d)(1)(iii).

In determining reasonable potential, EPA considers: 1) existing controls on point and non-point sources of pollution; 2) the variability of the pollutant or pollutant parameter in the effluent; 3) the sensitivity of the species to toxicity testing (when evaluating whole effluent toxicity); and 4) where appropriate, the dilution of the effluent in the receiving water. EPA typically considers the statistical approach outlined in *Technical Support Document for Water Quality-based Toxics Control (TSD)*¹ to determine if the discharge causes, or has the reasonable potential to cause, or contribute to an excursion above any WQS. *See* 40 C.F.R. § 122.44(d). EPA’s quantitative approach statistically projects effluent concentrations based on available effluent data, which are then compared to the applicable WQC.

2.2.5 State Certification

EPA may not issue a permit unless the State Water Pollution Control Agency with jurisdiction over the receiving water(s) either certifies that the effluent limitations contained in the permit are stringent enough to assure that the discharge will not cause the receiving water to violate the State WQSs or it is deemed that the state has waived its right to certify. Regulations governing state certification are set forth in 40 C.F.R. § 124.53 and § 124.55. EPA has requested permit certification by the State pursuant to 40 C.F.R. § 124.53 and expects that the Draft Permit will be certified.

If the State believes that any conditions more stringent than those contained in the Draft Permit are necessary to meet the requirements of either the CWA §§ 208(e), 301, 302, 303, 306 and 307 or the appropriate requirements of State law, the State should include such conditions and, in each case, cite the CWA or State law reference upon which that condition is based. Failure to provide such a citation waives the right to certify as to that condition. The only exception to this is that the sludge conditions/requirements implementing § 405(d) of the CWA are not subject to the § 401 State Certification requirements. Reviews and appeals of limitations and conditions attributable to State certification shall be made through the applicable procedures of the State and may not be made through the applicable procedures of 40 C.F.R. § 124.

In addition, the State should provide a statement of the extent to which any condition of the Draft Permit can be made less stringent without violating the requirements of State law. Since the State’s certification is provided prior to permit issuance, any failure by the State to provide this statement waives the State’s right to certify or object to any less stringent condition.

¹ March 1991, EPA/505/2-90-001

It should be noted that under CWA § 401, EPA's duty to defer to considerations of state law is intended to prevent EPA from relaxing any requirements, limitations or conditions imposed by state law. Therefore, "[a] State may not condition or deny a certification on the grounds that State law allows a less stringent permit condition." *See* 40 C.F.R. § 124.55(c). In such an instance, the regulation provides that, "The Regional Administrator shall disregard any such certification conditions or denials as waivers of certification." *Id.* EPA regulations pertaining to permit limits based upon water quality standards and state requirements are contained in 40 C.F.R. § 122.4 (d) and 40 C.F.R. § 122.44(d).

2.3 Effluent Flow Requirements

Sewage treatment plant discharge is encompassed within the definition of "pollutant" and is subject to regulation under the CWA. The CWA defines "pollutant" to mean, *inter alia*, "municipal...waste" and "sewage...discharged into water." 33 U.S.C. § 1362(6).

EPA may use design flow of wastewater effluent both to determine the necessity for effluent limitations in the permit that comply with the Act, and to calculate the limits themselves. EPA practice is to use design flow as a reasonable and important worst-case condition in EPA's reasonable potential and WQBEL calculations to ensure compliance with WQSs under § 301(b)(1)(C). Should the wastewater effluent flow exceed the flow assumed in these calculations, the instream dilution would decrease and the calculated effluent limits may not be protective of WQSs. Further, pollutants that do not have the reasonable potential to exceed WQSs at the lower wastewater discharge flow may have reasonable potential at a higher flow due to the decreased dilution. To ensure that the assumptions underlying the Region's reasonable potential analyses and derivation of permit effluent limitations remain sound for the duration of the permit, the Region may ensure its "worst-case" wastewater effluent flow assumption through imposition of permit conditions for wastewater effluent flow. Thus, the wastewater effluent flow limit is a component of WQBELs because the WQBELs are premised on a maximum level of flow. In addition, the wastewater effluent flow limit is necessary to ensure that other pollutants remain at levels that do not have a reasonable potential to exceed WQSs.

Using a facility's design flow in the derivation of pollutant effluent limitations, including conditions to limit wastewater effluent flow, is consistent with, and anticipated by NPDES permit regulations. Regarding the calculation of effluent limitations for POTWs, 40 C.F.R. § 122.45(b)(1) provides, "permit effluent limitations...shall be calculated based on design flow." POTW permit applications are required to include the design flow of the treatment facility. *Id.* § 122.21(j)(1)(vi).

Similarly, EPA's reasonable potential regulations require EPA to consider "where appropriate, the dilution of the effluent in the receiving water," 40 C.F.R. § 122.44(d)(1)(ii), which is a function of *both* the wastewater effluent flow and receiving water flow. EPA guidance directs that this "reasonable potential" analysis be based on "worst-case" conditions. EPA accordingly is authorized to carry out its reasonable potential calculations by presuming that a plant is operating at its design flow when assessing reasonable potential.

The limitation on wastewater effluent flow is within EPA's authority to condition a permit in order to carry out the objectives of the Act. *See* CWA §§ 402(a)(2) and 301(b)(1)(C); 40 C.F.R.

§§ 122.4(a) and (d); 122.43 and 122.44(d). A condition on the discharge designed to protect EPA's WQBEL and reasonable potential calculations is encompassed by the references to "condition" and "limitations" in 402 and 301 and implementing regulations, as they are designed to assure compliance with applicable water quality regulations, including anti-degradation. Regulating the quantity of pollutants in the discharge through a restriction on the quantity of wastewater effluent is consistent with the overall structure and purposes of the CWA.

In addition, as provided in Part II.B.1 of this permit and 40 C.F.R. § 122.41(e), the permittee is required to properly operate and maintain all facilities and systems of treatment and control. Operating the facilities wastewater treatment systems as designed includes operating within the facility's design wastewater effluent flow. Thus, the permit's wastewater effluent flow limitation is necessary to ensure proper facility operation, which in turn is a requirement applicable to all NPDES permits. *See* 40 C.F.R. § 122.41.

EPA has also included the wastewater effluent flow limit in the permit to minimize or prevent infiltration and inflow (I/I) that may result in unauthorized discharges and compromise proper operation and maintenance of the facility. Improper operation and maintenance may result in non-compliance with permit effluent limitations. Infiltration is groundwater that enters the collection system through physical defects such as cracked pipes or deteriorated joints. Inflow is extraneous flow added to the collection system that enters the collection system through point sources such as roof leaders, yard and area drains, sump pumps, manhole covers, tide gates, and cross connections from storm water systems. Significant I/I in a collection system may displace sanitary flow, reducing the capacity available for treatment and the operating efficiency of the treatment works and to properly operate and maintain the treatment works.

Furthermore, the extraneous flow due to significant I/I greatly increases the potential for sanitary sewer overflows (SSOs) in separate systems. Consequently, the effluent flow limit is a permit condition that relates to the permittee's duty to mitigate (*i.e.*, minimize or prevent any discharge in violation of the permit that has a reasonable likelihood of adversely affecting human health or the environment) and to properly operate and maintain the treatment works. *See* 40 C.F.R. §§ 122.41(d) and (e).

2.4 Monitoring and Reporting Requirements

2.4.1 Monitoring Requirements

EPA has the authority in accordance with several statutory and regulatory requirements established pursuant to the CWA, 33 USC § 1251 *et seq.*, the NPDES program (*See* § 402 and the implementing regulations generally found at 40 C.F.R. §§ 122, 124, 125, and 136), CWA § 308(a), 33 USC § 1318(a), and applicable state regulations to include requirements such as monitoring and reporting in NPDES permits.

The monitoring requirements included in this permit have been established to yield data representative of the discharges under the authority of §§ 308(a) and 402(a)(2) of the CWA, and consistent with 40 C.F.R. §§ 122.41(j), 122.43(a), 122.44(i) and 122.48. The monitoring requirements included in this permit specify routine sampling and analysis, which will provide ongoing, representative information on the levels of regulated constituents in the wastewater

discharge streams. The monitoring program is needed to assess effluent characteristics, evaluate permit compliance, and determine if additional permit conditions are necessary to ensure compliance with technology-based and water quality-based requirements, including WQSs. EPA and/or the state may use the results of the chemical analyses conducted pursuant to this permit, as well as national water quality criteria developed pursuant to § 304(a)(1) of the CWA, state water quality criteria, and any other appropriate information or data, to develop numerical effluent limitations for any pollutants, including, but not limited to, those pollutants listed in Appendix D of 40 C.F.R. § 122. Therefore, the monitoring requirements in this permit are included for specific regulatory use in carrying out the CWA.

NPDES permits require that the approved analytical procedures found in 40 C.F.R. § 136 be used for sampling and analysis unless other procedures are explicitly specified. Permits also include requirements necessary to comply with the *National Pollutant Discharge Elimination System (NPDES): Use of Sufficiently Sensitive Test Methods for Permit Applications and Reporting Rule*.² This Rule requires that where EPA-approved methods exist, NPDES applicants must use sufficiently sensitive EPA-approved analytical methods when quantifying the presence of pollutants in a discharge. Further, the permitting authority must prescribe that only sufficiently sensitive EPA-approved methods be used for analyses of pollutants or pollutant parameters under the permit. The NPDES regulations at 40 C.F.R. § 122.21(e)(3) (completeness), 40 C.F.R. § 122.44(i)(1)(iv) (monitoring requirements) and/or as cross referenced at 40 C.F.R. § 136.1(c) (applicability) indicate that an EPA-approved method is sufficiently sensitive where:

- The method minimum level³ (ML) is at or below the level of the applicable water quality criterion or permit limitation for the measured pollutant or pollutant parameter; or
- In the case of permit applications, the ML is above the applicable water quality criterion, but the amount of the pollutant or pollutant parameter in a facility's discharge is high enough that the method detects and quantifies the level of the pollutant or parameter in the discharge; or
- The method has the lowest ML of the EPA-approved analytical methods.

2.4.2 Reporting Requirements

The Draft Permit requires the Permittee to electronically report monitoring results obtained during each calendar month as a Discharge Monitoring Report (DMR) to EPA and the State using NetDMR no later than the 15th day of the month following the completed reporting period.

² Federal Register, Vol. 79, No. 160, Tuesday, August 19, 2014; FR Doc. 2014–19557.

³ The term “minimum level” refers to either the sample concentration equivalent to the lowest calibration point in a method or a multiple of the method detection limit (MDL). Minimum levels may be obtained in several ways: They may be published in a method; they may be sample concentrations equivalent to the lowest acceptable calibration point used by a laboratory; or they may be calculated by multiplying the MDL in a method, or the MDL determined by a lab, by a factor. EPA is considering the following terms related to analytical method sensitivity to be synonymous: “quantitation limit,” “reporting limit,” “level of quantitation,” and “minimum level.” See Federal Register, Vol. 79, No. 160, Tuesday, August 19, 2014; FR Doc. 2014–19557.

NetDMR is a national web-based tool for regulated CWA permittees to submit DMRs electronically via a secure internet application to EPA through the Environmental Information Exchange Network. NetDMR has allowed participants to discontinue mailing in hard copy forms to EPA under 40 C.F.R. §§ 122.41 and 403.12. NetDMR is accessed from the following website: <https://netdmr.zendesk.com/hc/en-us>. Further information about NetDMR can be found on the EPA Region 1 NetDMR website.⁴

With the use of NetDMR, the Permittee is no longer required to submit hard copies of DMRs and reports to EPA and the State unless otherwise specified in the Draft Permit. In most cases, reports required under the permit shall be submitted to EPA as an electronic attachment through NetDMR. Certain exceptions are provided in the permit, such as for providing written notifications required under the Part II Standard Conditions.

2.5 Anti-backsliding

A permit may not be renewed, reissued or modified with less stringent limitations or conditions than those contained in a previous permit unless in compliance with the anti-backsliding requirements of the CWA. See §§ 402(o) and 303(d)(4) of the CWA and 40 C.F.R. § 122.44(1)(1 and 2). Anti-backsliding provisions apply to effluent limits based on technology, water quality, BPJ and state certification requirements.

All proposed limitations in the Draft Permit are at least as stringent as limitations included in the 2007 Permit unless specific conditions exist to justify one of the exceptions listed in 40 C.F.R. § 122.44(1)(2)(i) and/or in accordance with § 303(d)(4). Discussion of any applicable exceptions are discussed in sections that follow. Therefore, the Draft Permit complies with the anti-backsliding requirements of the CWA.

3 Location and Type of Facility

The location of the treatment plant and the outfall 001 to Housatonic River are shown in Figure 1. The location of the outfall is Latitude 42°20'56" N, Longitude 73°14'43" W.

The Lenox Wastewater Treatment Plant (WWTP) is a secondary wastewater treatment facility that is engaged in the collection and treatment of municipal wastewater. Currently, the Facility serves approximately 6,000 residents in the Town of Lenox.

Since 1998 this facility has received treated wastewater flow from the former Lenox Dale WWTP, which was converted into a pump station and taken off-line. The Lenox WWTP has a design flow of 1.8 MGD, the annual average daily flow reported in the 2012 application was 0.75 MGD, and the average for the last 5 years has been 0.619 MGD. The annual average flow is expected to remain below the 1.19 MGD flow limitation in the current permit for the next several years. Therefore, the proposed effluent limitations on page 2 of the Draft Permit were calculated using the 2007 Permit's flow limitation of 1.19 MGD (combined flows from Lenox and Lenox

⁴ <https://netdmr.zendesk.com/hc/en-us/articles/209616266-EPA-Region-1-NetDMR-Information>.

Dale) and not the Facility's design flow of 1.8 MGD. Increases in the discharge can only be authorized consistent with water quality standards, including the Massachusetts Antidegradation Policy found at 314 CMR § 4.04. Since the flow limitation in the 2007 Permit has been maintained in the Draft Permit, a formal antidegradation review process is not required for the permit action. The system is a separate system with no combined sewers. Wastewater is comprised of domestic sewage.

The permittee does not have any major industries contributing industrial wastewater to the WWTP, and thus is not required to have a pretreatment program.

A quantitative description of the discharge in terms of effluent parameters, based on monitoring data submitted by the permittee from January 2014 through December 2018 is provided in Appendix A of this Fact Sheet.

3.1.1 Treatment Process Description

The Lenox Wastewater Treatment Plant (WWTP) is a municipal secondary wastewater treatment plant. Influent enters the Facility and flows through an aerated grit chamber followed by gravity flow in two aeration basins. The aeration basin effluent flows by gravity to a distribution structure that provides PAC for phosphorus removal, and then divides the flow into three (3) secondary clarifiers. The secondary effluent is disinfected in a chlorine contact chamber, and the chlorinated effluent is discharged to the Housatonic River. A flow diagram of the Lenox WWTP shown in Figure 2.

Return sludge from the secondary clarifiers is pumped to the aeration basins, and waste sludge is pumped from the clarifiers to a gravity belt thickener. The sludge cake is stored in a container for offsite disposal. Sludge from this facility is transported offsite by The average mass of sludge shipped for incineration in 2012 was 132.5 dry metric tons.

3.1.2 Collection System Description

The Lenox WWTP is served by a separate sewer system with no combined sewers. A separate sanitary sewer conveys domestic, industrial and commercial sewage, but not stormwater. It is part of a "two pipe system" consisting of separate sanitary sewers and storm sewers. The two systems have no interconnections; the sanitary sewer leads to the wastewater treatment plant and the storm sewers discharge to a local water body.

4 Description of Receiving Water and Dilution

The Lenox WWTP discharges through Outfall 001 into the Housatonic River, a tributary of the Connecticut River, within Segment MA21-19. This segment is 1.3 miles in length and travels from the outlet of Woods Pond dam in Lee/Lenox to the Risingdale Impoundment Dam in Great Barrington. The Housatonic River flows into Long Island Sound near Stratford, Connecticut. The Housatonic River has been classified as a Class B warm water fishery in the Massachusetts WQSs, 314 Code of Massachusetts Regulations ("CMR") 4.05(4)(a). The MA WQS at 314 CMR 4.05(3)(b) state that Class B "*waters are designated as a habitat for fish, other aquatic life, and wildlife, including for their reproduction, migration, growth and other critical functions, and*

for primary and secondary contact recreation. Where designated in 314 CMR 4.06, they shall be suitable as a source of public water supply with appropriate treatment (“Treated Water Supply”). Class B waters shall be suitable for irrigation and other agricultural uses and for compatible industrial cooling and process uses. These waters shall have consistently good aesthetic value.”

The MassDEP’s Massachusetts Year 2014 Integrated List of Waters (2014 Integrated List), the 303(d) list, includes the Housatonic River as a Massachusetts Category 5 Water and in need of a total maximum daily load (TMDL) assessment due to, excess algal growth, total phosphorus, and polychlorinated biphenyls, PCB in fish tissue, and Zebra mussel. This assessment is based on the sampling results of the 2002 Housatonic River Water Quality Assessment conducted by MassDEP. To date no TMDL has been developed for this segment for any of the listed impairments.

In 1981, the Massachusetts Department of Environmental Quality Engineering (DEQE) published the Housatonic River Water Quality Management Plan, which included a wasteload allocation (WLA) for the Lenox WWTP. Given the limited assimilative capacity of the receiving waters, limits more stringent than secondary treatment requirements were required for the parameters in Table 1.

Table 1: Limits in 1981 MA DEQE Wasteload Allocation

Source	Flow (MGD)	BOD ₅ (lb/day)	TSS (lb/day)	Fecal coliform (#/100 mL)	Total coliform (#/100 mL)	Settleable Solids (mg/L)
Lenox	0.91	228	228	200	1000	0.1
Lenox Dale	0.28	70	70	200	1000	0.1

*WLA apply the limits only April 1-October 15. MassDEP has revised the “summer” or “growing season” as May 1 through October 31. EPA has adopted these dates in applying the WLA limits.

EPA has proposed effluent limits in the Draft Permit that ensure that the increased discharge does not result in a significant degradation of water quality in the Housatonic River and the downstream waters.

4.1 Available Dilution

7-Day, 10-Year Low Flow

To ensure that discharges do not cause or contribute to violations of WQS under all expected circumstances, WQBELs are derived assuming critical conditions for the receiving water ([See EPA Permit Writer’s Manual, Section 6.2.4](#)). For most pollutants and criteria, the critical flow in rivers and streams is some measure of the low flow of that river or stream. Massachusetts water quality regulations require that the available effluent dilution be based on the 7-day, 10-year low flow (7Q10 flow) of the receiving water (314 CMR 4.03(3)(1)). The 7Q10 low flow is the mean low flow over 7 consecutive days, recurring every 10 years.

The 7Q10 flow used in the Draft Permit has been extrapolated from flow data from the most recent 30 years (1998 – 2018) at a U.S. Geological Survey gage station (USGS 01197500 - Housatonic River at Great Barrington, Massachusetts) on the Housatonic River. The discharge is

located immediately upstream of the Woods Pond Dam, on the Housatonic River. The total drainage area for the Housatonic River watershed is about 1,948 square miles; the drainage area upstream of the discharge is about 170 square miles.

7Q10 at USGS 01197500 – Housatonic River at Great Barrington, Massachusetts April 1, 1988-April 1, 2018

= 66.4 cubic feet per second (cfs)

Drainage Area = 282 square miles

$$\text{Flow factor for USGS \#01197500} = \frac{66.4 \text{ cfs}}{282 \text{ square miles}} = 0.235 \text{ cfs/sq.mi.}$$

Using a low-flow factor of 0.235 cfs per square mile yields a receiving water 7Q10 flow of about 40.0 cfs or 25.8 million gallons per day (MGD).

The dilution factor (DF) at the 7Q10 flow of 25.8 MGD in the receiving water upstream of the discharge, Q_s , and the Facility's design flow of 1.19 MGD, Q_d , was calculated as shown below:

$$DF = (Q_s + Q_d)/Q_d = (25.8 \text{ MGD} + 1.19 \text{ MGD})/1.19 \text{ MGD} = 22.7$$

5 Proposed Effluent Limitations and Conditions

The proposed limitations and conditions, the bases of which are discussed throughout this Fact Sheet, may be found in Part I of the Draft Permit. EPA determined the pollutants of concern based on EPA's technology based effluent requirements, pollutants believed present in the permit application, and other information.

5.1 Effluent Limitations and Monitoring Requirements

In addition to the State and Federal regulations described in Section 2, data submitted by the permittee in their permit application as well as in monthly discharge monitoring reports (DMRs) and in WET test reports from January 2014 to December 2018 (the "review period") were used to identify the pollutants of concern and to evaluate the discharge during the effluent limitations development process (See Appendix A).

5.1.1 Wastewater Effluent Flow

The monthly effluent flow limit in the 2007 Permit is 1.19 MGD, as a rolling annual average flow. The DMR data during the review period shows that there have been no violations of the flow limit.

The Draft Permit continues the 1.19 MGD monthly average flow limit from the 2007 Permit. The Draft Permit requires that flow be measured continuously and that the rolling annual average flow, as well as the average monthly and maximum daily flow for each month be reported. The rolling annual average flow is calculated as the average of the flow for the reporting month and

11 previous months.

5.1.2 Biochemical Oxygen Demand (BOD₅)

5.1.2.1 BOD₅ Concentration Limits

The BOD₅ limits in the 2007 Permit were based on the secondary treatment standards in 40 C.F.R. § 133.102; the average monthly limit is 30 mg/L and the average weekly limit is 45 mg/L. The DMR data during the review period shows that there have been no violations of BOD₅ concentration limits.

The Draft Permit proposes the same BOD₅ concentration limits as in the 2007 Permit as no new WLAs have been established and there have been no changes to the secondary treatment standards. The monitoring frequency remains once per week.

5.1.2.2 BOD₅ Mass Limits

The mass-based BOD₅ limits in the 2007 Permit of 300 lb/day (monthly average) and 450 lb/day (weekly average) were based on EPA's secondary treatment standards and the design flow of the Facility. The DMR data from the review period shows that there have been no violations of BOD₅ mass limits.

BOD Mass Loading Calculations:

Calculations of maximum allowable loads for average monthly and average weekly BOD₅ are based on the following equation:

$$L = C_d * Q_d * 8.34$$

Where:

L = Maximum allowable load in lb/day

C_d = Maximum allowable effluent concentration for reporting period in mg/L
(reporting periods are average monthly and average weekly)

Q_d = Annual average design flow of Facility

8.34 = Factor to convert effluent concentration in mg/L and design flow in MGD to lb/day

Limits:

Monthly Average: 30 mg/L * 1.19 MGD * 8.34 = 300 lb/day

Weekly Average: 45 mg/L * 1.19 MGD * 8.34 = 450 lb/day

The limits are still well above the level of BOD₅ currently being discharged and therefore EPA expects that the Facility will continue to meet their BOD₅ limits without any further adjustments to their treatment process.

5.1.3 Total Suspended Solids (TSS)

5.1.3.1 TSS Concentration Limits

The TSS limits in the 2007 Permit were based on the secondary treatment standards in 40 C.F.R. § 133.102; the average monthly limit is 30 mg/L and the average weekly limit is 45 mg/L. The DMR data during the review period shows that there have been no violations of TSS concentration limits.

The Draft Permit proposes the same TSS concentration limits as in the 2007 Permit as no new WLAs have been established and there have been no changes to the secondary treatment standards. The monitoring frequency remains once per week.

5.1.3.2 TSS Mass Limits

The mass-based TSS limits in the 2007 Permit of 300 lb/day (monthly average) and 450 lb/day (weekly average) were based on EPA's secondary treatment standards and the design flow of the Facility.

The DMR data during the review period shows that there have been no violations of TSS mass limits.

TSS Mass Loading Calculations:

Calculations of maximum allowable loads for average monthly and average weekly TSS are based on the following equation:

$$L = C_d * Q_d * 8.34$$

Where:

L	=	Maximum allowable load in lb/day
C _d	=	Maximum allowable effluent concentration for reporting period in mg/L (reporting periods are average monthly and average weekly)
Q _d	=	Annual average design flow of Facility
8.34	=	Factor to convert effluent concentration in mg/L and design flow in MGD to lb/day

Limits:

Monthly Average:	30 mg/L * 1.19 MGD * 8.34 = 300 lb/day
Weekly Average:	45 mg/L * 1.19 MGD * 8.34 = 450 lb/day

The limits are still well above the level of TSS currently being discharged and therefore EPA expects that the Facility will continue to meet their TSS limits.

5.1.4 Eighty-Five Percent (85%) BOD₅ and TSS Removal Requirement

In accordance with the provisions of 40 C.F.R. § 133.102(a)(3), (4) and (b)(3), the 2007 Permit

requires that the 30-day average percent removal for BOD₅ and TSS be not less than 85%. The DMR data during the review period shows that BOD₅ and TSS removal percentages averaged 97% and 97%, respectively. There were no violations of the 85% removal requirement for BOD₅, and 1 violation of the 85% removal requirement for TSS during that period.

The requirement to achieve 85% BOD₅ and TSS removal has been carried forward into the Draft Permit.

5.1.5 pH

Consistent with the requirements of Massachusetts WQS at 314 CMR 4.05(3)(b)(3), the Permit requires that the pH of the effluent is not less than 6.5 or greater than 8.3 standard units at any time. The monitoring frequency is once per day. The DMR data during the review period show that there have been no violations of the pH limitations.

The pH requirements in the 2007 Permit are carried forward into the Draft Permit as there has been no change in the WQS with regards to pH.

5.1.6 Bacteria

The 2007 Permit includes seasonal limits for *Escherichia coli* (*E. coli*) consistent with Massachusetts' new bacteria criteria, which were approved by EPA on September 19, 2007. The *E. coli* limits, which apply from April 1st to October 31st are 126 colony forming units (cfu) of *E. coli* per 100 milliliters (ml) as a monthly average geometric mean and 409 cfu of *E. coli* per 100 ml maximum daily value (this is the 90% distribution of the geometric mean of 126 cfu/100 ml) and require weekly monitoring. As can be seen from the DMR summary in Appendix A, during the five-year period of January 2014 through December of 2018, the permittee reported only one exceedance of the daily maximum *E. coli* effluent limit in 2014 and no exceedances of the monthly average limit.

The 2007 Permit also included temporary seasonal effluent limitations for fecal coliform bacteria limits since Massachusetts was, at that time, transitioning from fecal coliform-based bacteria criteria to newly adopted *E. coli* criteria to protect recreational uses.

As there has been no change to the Massachusetts recreational criteria since 2007, the *E. coli* bacteria limits and monitoring requirements from the 2007 Permit are continued in the Draft Permit.

5.1.7 Total Residual Chlorine

The 2007 Permit includes water quality based effluent limits for TRC of 0.23 mg/L monthly average and maximum daily 0.40 mg/L with a daily monitoring requirement. As can be seen from the DMR summary in Appendix A, the permittee reported no TRC limit exceedances during the five-year period of January 2014 through December of 2018.

The TRC permit limits are based on the instream chlorine criteria defined in National Recommended Water Quality Criteria: 2002, EPA 822R-02-047 (November 2002), as adopted by the MassDEP into the state water quality standards at 314 CMR 4.05(5)(e). The freshwater

instream criteria for chlorine are 11 ug/l (chronic) and 19 ug/l (acute). EPA calculated TRC limits based on the updated dilution factor of 34.4. Because the upstream chlorine is assumed to be zero in this case, the water quality-based chlorine limits are calculated using the criteria and the dilution factor, as follows:

Chronic criteria * dilution factor = Chronic limit

11 µg/l * 22.7 = 250 µg/L = 0.250 mg/L (average monthly)

Acute criteria * dilution factor = Acute limit

19 µg/l * 22.7 = 431 µg/L = 0.431 mg/L (maximum daily)

The Draft Permit retains the 0.23 mg/L monthly average and maximum daily 0.40 mg/L TRC limits from the 2007 permit based on anti-backsliding provisions found in CWA section 402(o)(1) (see Section 2.5 of this Fact Sheet for more information about anti-backsliding). Since the permittee is already meeting the limits in the 2007 permit and there have been no regulatory changes since the 2007 permit was issued, there are no applicable exceptions to the anti-backsliding provisions in the CWA. The draft permit expresses the TRC limits in micrograms per liter instead of milligrams per liter consistent with current practice and continues the once-per-day monitoring requirement.

5.1.8 Ammonia

In addition to being a nutrient as a component of total nitrogen, nitrogen in the form of ammonia can reduce the receiving stream's dissolved oxygen concentration through nitrification and can be toxic to aquatic life, particularly at elevated temperatures. The toxicity level of ammonia depends on the temperature and pH of the receiving water (USEPA 1999). The 2007 Permit includes a weekly ammonia monitoring requirement.

Summer Ammonia Limits (April 1 – October 30)

The applicable ammonia water quality criteria are pH and, for the chronic criteria, temperature dependent and can be derived using EPA-recommended ammonia criteria from the document: *Update of Ammonia Water Quality Criteria for Ammonia*, 1999 (EPA 822-R-99-014). These are the freshwater ammonia criteria in EPA's *National Recommended Water Quality Criteria*, 2002 (EPA 822-R-02-047) document, which are included by reference in the Massachusetts WQS (See 314 CMR 4.05(5)(e)). At pH of 7.0, average summer temperature of 20°C, and assuming salmonids present, the acute criteria is 24.1 mg/L and the chronic criteria is 4.15 mg/L.

The DMR data during the review period shows one sample of 6.4 mg/L, and the rest were < 2.8 mg/L.

To determine whether the effluent has the reasonable potential to cause or contribute to an exceedance above the in-stream water quality criteria for ammonia, the following mass-balance is used to project the in-stream concentration downstream from the discharge.

Downstream Ammonia Concentration
(April 1 – October 30)

$$Q_R C_R = Q_D C_D + Q_S C_S$$

Where

Q_R	=	Streamflow below outfall	=	41.84 cfs ($Q_D + Q_S$)
Q_D	=	Discharge flow	=	1.84 cfs
C_D	=	Discharge concentration	=	3.39 mg/L (95% daily max estimate)
Q_S	=	Upstream flow	=	40.0 cfs (7Q10)
C_S	=	Upstream concentration	=	0.1 mg/L*
C_R	=	Concentration below outfall		

Solving for downstream concentration,

$$C_R = (Q_D C_D + Q_S C_S) / Q_R$$

$$C_R = \frac{(1.84 \text{ cfs} \times 3.39 \text{ mg/L}) + (40.0 \text{ cfs} \times 0.1 \text{ mg/L})}{41.84 \text{ cfs}}$$

$$C_R = 0.24 \text{ mg/L, which is less than } 4.15 \text{ mg/L.}$$

*Absent data from Lenox, assumed concentration based on other data from the area

Analysis shows there is not Reasonable Potential to violate the acute or chronic ammonia criteria. Because the downstream concentration is well below the ammonia water quality criteria, the Draft Permit continues the monitoring frequency at 1/month.

Winter Ammonia Limits (November 1 – March 31)

At pH of 7.0, average winter temperature of 5°C, and assuming salmonids present, the acute and chronic ammonia criteria are 24.1 mg/L and 5.91 mg/L, respectively. The DMR data during the review period shows one sample of 3.1 mg/L, and the rest were < 0.8 mg/L.

Since all readings were well below the chronic and acute criteria, there is not reasonable potential to violate the acute or chronic ammonia limits. Because the downstream ammonia concentration is well below the water quality criteria, the Draft Permit continues the monitoring requirement at a reduced frequency of once per month.

5.1.9 Nutrients

Nutrients are compounds containing nitrogen and phosphorus. Although nitrogen and phosphorus are essential for plant growth, high concentrations of these nutrients can cause eutrophication, a condition in which aquatic plant and algal growth is excessive. Plant and algae respiration and decomposition reduces dissolved oxygen in the water, creating poor habitat for fish and other aquatic animals. Recent studies provide evidence that both phosphorus and nitrogen can play a role in the eutrophication of certain ecosystems. However, typically phosphorus is the limiting nutrient triggering eutrophication in fresh water ecosystems and nitrogen in marine or estuarine ecosystems. Thus, for this receiving water, this permit,

phosphorus [or nitrogen or both] is the nutrient of concern evaluated for effluent limitations in the discussion below.

5.1.9.1 Total Nitrogen

The Lenox WWTP discharges to the Housatonic River, which drains to Long Island Sound (LIS). In December 2000, the Connecticut Department of Energy and Environmental Protection (CT DEEP) and New York State Department of Environmental Conservation (NYSDEC) completed a Total Maximum Daily Load (TMDL) for addressing nitrogen-driven eutrophication impacts in LIS. The TMDL included a Waste Load Allocation (WLA) for point sources and a Load Allocation (LA) for non-point sources. The point source WLA for out-of-basin sources (Massachusetts, New Hampshire and Vermont point sources discharging to the Connecticut, Housatonic and Thames River watersheds) requires an aggregate 25% reduction from the baseline total nitrogen loading estimated in the TMDL.

The 1998 baseline out-of-basin total nitrogen point source loadings estimated for the Connecticut, Housatonic, and Thames River watersheds were 21,672 lb/day, 3,286 lb/day, and 1,253 lb/day respectively (See Table 2: Estimated Out-of-Basin Point Source Nitrogen Loadings to the Connecticut, Housatonic and Thames Rivers Watersheds below) including those from publicly and privately owned treatment works, or wastewater treatment plants (WWTPs), and industrial dischargers. Recent estimated point source maximum annual average total nitrogen loadings for the Connecticut, Housatonic, and Thames, Rivers, respectively are 14,395 lb/day, 1,628 lb/day, and 666 lb/day, based on 2013 through 2017 information and including all non-stormwater permitted dischargers in the watershed.

As can be seen in Table 2, the TMDL target of a 25% aggregate reduction from the 1998 baseline loadings is currently being met, and the overall loading from MA, NH and VT wastewater treatment plants discharging to the Housatonic River watershed is about 34% below the TMDL wasteload allocation. Overall the loadings from MA, NH, and VT are about 15% below the TMDL wasteload allocation.

Table 2: Estimated Out-of-Basin Point Source Nitrogen Loadings to the Connecticut, Housatonic and Thames Rivers Watersheds

Basin	1998 Baseline Loading ¹ (lb/day)	TMDL WLA ² (lb/day)	Maximum Loading 2013 to 2017 (lb/day) ³
Connecticut River	21,672	16,254	14,395 ⁴
Housatonic River	3,286	2,464	1,628 ⁵
Thames River	1,253	939	666 ⁶
Totals	26,211	19,657	16,689

¹ Estimated loading from TMDL, (see Appendix 3 to CT DEEP “Report on Nitrogen Loads to Long Island Sound,” April 1998)

² Reduction of 25% from baseline loading

³ Estimated loading from 2013-2017 Discharge Monitoring Report data

⁴Highest load from the Connecticut River occurred in 2013

⁵Highest load from the Housatonic River occurred in 2014

⁶Highest load from the Thames River occurred in 2015

The 2007 Permit required monthly monitoring for total Kjeldahl nitrogen, nitrate and nitrite, the sum of which provide the total nitrogen (TN) concentration. Using the concentration and

monthly average flow data, the calculated⁵ annual average⁶ total nitrogen loading from the Lenox facility ranged from 49 to 78 lb/day from 2014 to 2018 and averaged 65 lb/day.

While substantial TN out-of-basin load reductions have occurred at some facilities by means of optimization requirements alone, concerns raised in recent public comments by the downstream state (Connecticut) and concerned citizens⁷ have highlighted the need for clearly enforceable, numeric, loading-based effluent limits to ensure that the annual aggregate nitrogen loading from out-of-basin point sources are consistent with the TMDL WLA of 19,657 lb/day and to ensure that current reductions in loading do not increase, given the continued impairment status of LIS.

After further review of the federal and state requirements, EPA agrees with the concerns raised by the downstream state and the public. As discussed in Section 2 of this Fact Sheet, statutory and regulatory requirements regarding the development of water quality-based effluent limits include provisions to ensure implementation of any available WLAs⁸, provisions to prevent further degradation of receiving waters that are already impaired⁹ and consideration of applicable water quality requirements of downstream states¹⁰.

The optimization requirements included, in many out-of-basin permits issued in the LIS watershed since 2007, have resulted in nitrogen reductions by means of utilizing the available equipment to minimize discharges of nitrogen. However, these requirements, by themselves, are not enforceable effluent limits that would prevent further increases in nitrogen due to population growth or new industrial dischargers. Enforceable effluent limits will ensure that as communities experience new residential, commercial and industrial growth, the nitrogen load from their POTWs do not cause or contribute to further degradation of LIS.

Therefore, EPA intends to include a total nitrogen rolling annual average mass-based loading limit (in lb/day) and a requirement to optimize current treatment systems to minimize the effluent nitrogen in all permits issued to wastewater treatment plants with design flow greater than or equal to one (1) MGD that discharge to the LIS watershed in Massachusetts. Table 3 summarizes the approach to update TN requirements for this and future permits in the LIS watershed in Massachusetts. EPA is also working with the States of New Hampshire and Vermont to ensure that comparable requirements are included in NPDES permits issued in those states.

⁵ Monthly Average TN (mg/L) * Monthly Average Flow * 8.34 = Monthly Average TN (lb/day)

⁶ Sum of Monthly Average TN (lb/day) in a year ÷ 12 months = Annual Average

⁷ Connecticut Department of Energy and Environmental Protection letters to EPA dated February 7, 2018 and April 27, 2018; Connecticut Fund for the Environment letter to EPA dated February 7, 2018; and Connecticut River Conservancy letter to EPA dated February 18, 2018.

⁸ See 40 C.F.R. § 122.44(d)(1)(vii)(B)

⁹ See 40 C.F.R. § 122.44(d)(1)(vii)(B), 40 C.F.R. § 131.12(a)(1), and 314 CMR 4.04(1)

¹⁰ See 40 C.F.R. § 122.44(d)(4) and CWA section 401(a)(2)

Table 3 - Annual Average Total Nitrogen Limits for Massachusetts WWTP Dischargers to the Long Island Sound Watershed

Facility Design Flow, Q_D (MGD)	Number of Facilities	Annual Average TN Limit (lb/day)
$Q_D \geq 50$	1	Q_D (MGD) * 5 mg/L * 8.34 + optimize
$10 \leq Q_D < 50$	3	Q_D (MGD) * 5 mg/L * 8.34 + optimize
$5 \leq Q_D < 10$	6	Q_D (MGD) * 8 mg/L * 8.34 + optimize
$1 \leq Q_D < 5$	19	Q_D (MGD) * 10 mg/L * 8.34 + optimize
$0.1 \leq Q_D < 1$	17	Optimize
$Q_D < 0.1$	8	TN monitoring only

The optimization condition in the Draft Permit requires the permittee to evaluate alternative methods of operating their treatment plant to optimize the removal of nitrogen, and to describe previous and ongoing optimization efforts. Facilities not currently engaged in optimization efforts will also be required to implement optimization measures, so that the aggregate 25% reduction is maintained or increased.

Specifically, the Draft Permit requires an evaluation of alternative methods of operating the existing wastewater treatment facility to control total nitrogen levels, including, but not limited to, operational changes designed to enhance nitrification (seasonal and year-round), incorporation of anoxic zones, septage receiving policies and procedures, and side stream management. This evaluation is required to be completed and submitted to EPA and MassDEP within one year of the effective date of the permit, along with a description of past and ongoing optimization efforts. The permit also requires implementation of optimization methods to ensure that the facility is operated in such a way that discharges of total nitrogen are minimized. The permit requires annual reports to be submitted that summarize progress and activities related to optimizing nitrogen removal efficiencies and track trends relative to previous years.

In addition to the rolling annual average total nitrogen effluent limit and optimization requirements, the draft permit includes weekly monitoring and average monthly reporting requirements for total nitrogen (TN), total Kjeldahl nitrogen (TKN), and total nitrite/nitrate nitrogen (NO_2/NO_3).

Since the design flow for the facility is between 1 and 5 MGD (1.19 MGD), the annual loading TN limit calculated for the Draft Permit is:

$$1.19 \text{ MGD} * 10 \text{ mg/L} * 8.34 = 99.2 \text{ lb/day.}$$

The effluent limit is a rolling annual average based on the average of the current monthly average and the monthly average of the previous 11 months.

Future Nitrogen Limits

The new nitrogen annual loading limit in this draft permit is intended to meet the requirements of the 2001 LIS TMDL which was developed to address hypoxic conditions in the bottom waters of

LIS¹¹. In December 2015, EPA signed a letter detailing a post-TMDL EPA nitrogen reduction strategy for waters in the LIS watershed. The strategy recognizes that more work may need to be done to reduce nitrogen levels, further improve DO conditions, and attain other related water quality standards in LIS, particularly in coastal embayments and the estuarine portions of rivers that flow into the Sound. EPA is working to establish nitrogen thresholds for Western LIS and several coastal embayments, including the mouth of the Housatonic River. Documents regarding the EPA Nitrogen Reduction Strategy are available for public review on EPA's Long Island Sound website (<http://longislandsoundstudy.net/issues-actions/water-quality/nitrogen-strategy/>). Upon completion of establishing thresholds and assessing the water quality conditions of the estuarine waters of the Housatonic River, allocations of total nitrogen loadings may be lowered if further reductions are necessary. If reductions are needed for the Lenox discharge, a lower water quality-based effluent limit will be added in a future permit action. If so, EPA anticipates exploring possible trading approaches for nitrogen loading in the Massachusetts portion of the Housatonic River watershed.

Although not a permit requirement, it is recommended that any facilities planning that might be conducted for this facility consider alternatives for further enhancing nitrogen reduction beyond the optimization activities required in this permit.

5.1.9.2 Total Phosphorus

While phosphorus is an essential nutrient for the growth of aquatic plants, it can stimulate rapid plant growth in freshwater ecosystems when it is present in high quantities. The excessive growth of aquatic plants and algae within freshwater systems negatively impacts water quality and can interfere with the attainment of designated uses by: 1) increasing oxygen demand within the water body to support an increase in both plant respiration and the biological breakdown of dead organic (plant) matter; 2) causing an unpleasant appearance and odor; 3) interfering with navigation and recreation; 4) reducing water clarity; 5) reducing the quality and availability of suitable habitat for aquatic life; and 6) producing toxic cyanobacteria during certain algal blooms. Cultural (or accelerated) eutrophication is the term used to describe dense and excessive plant growth in a water body that results from nutrients entering the system due to human activities. Discharges from municipal and industrial wastewater treatment plants, agriculture runoff, and stormwater are examples of human-derived (i.e. anthropogenic) sources of nutrients in surface waters.

The 2007 Permit includes a monthly average effluent limit of 1.0 mg/L effective year-round. Review of the weekly monitoring data in the DMRs from January 2014 to December 2018, provided in Appendix A, shows that in the warm months the monthly average total phosphorus in the effluent averaged 0.23 mg/L (range 0.04 to 0.53 mg/L) and in the cold months, the monthly average total phosphorus averaged 0.18 mg/L (range 0.07 to 0.43 mg/L).

The MA WQS under 314 CMR 4.05(5)(c) requires that, unless naturally occurring, surface waters must be free from nutrients that cause or contribute to impairment of the existing or designated uses, and the concentration of phosphorus may not exceed site specific criteria

¹¹ For more information see <http://longislandsoundstudy.net/about/our-mission/management-plan/hypoxia/>

develop in a TMDL. Nutrients are also prohibited in concentrations that would cause or contribute to cultural eutrophication.

In the absence of numeric criteria for phosphorus, EPA uses nationally recommended criteria and other technical guidance to develop effluent limitations for the discharge of phosphorus. EPA has published national guidance documents that contain recommended total phosphorus criteria and other indicators of eutrophication. The following summarizes the available guidance:

- EPA's 1986 *Quality Criteria for Water* (the "Gold Book") recommends that in-stream phosphorus concentrations not exceed 0.05 mg/L in any stream entering a lake or reservoir, 0.1 mg/L for any stream not discharging directly to lakes or impoundments, and 0.025 mg/L within a lake or reservoir. For this segment of the Housatonic River, the 0.05 mg/L (50 µg/L) criterion would apply downstream of the discharge because the discharge is into a river where it enters an impoundment.

As the Gold Book notes, there are natural conditions of a water body that can result in either increased or reduced eutrophication response to phosphorus inputs; in some waters more stringent phosphorus reductions may be needed, while in some others a higher total phosphorus threshold could be assimilated without inducing a eutrophic response. In this case, EPA is not aware of any evidence that the Housatonic River is unusually susceptible to eutrophication impacts, so that the 50 µg/L threshold appears sufficient in this receiving water. EPA is not aware of evidence of factors that are reducing eutrophic response in the Housatonic River downstream of the discharge.

- In 2001, EPA released recommended Ecoregional Nutrient Criteria, established as part of an effort to reduce problems associated with excess nutrients in water bodies in specific areas of the country. The published criteria represent conditions in waters within ecoregions that are minimally impacted by human activities, and thus free from the effects of cultural eutrophication. Lenox is located within Ecoregion VIII, Nutrient Poor, Largely Glaciated Upper Midwest and Northeast. The recommended total phosphorus criteria for this ecoregion, found in *Ambient Water Quality Criteria Recommendations: Information Supporting the Development of State and Tribal Nutrient Criteria, Rivers and Streams in Ecoregion VIII* (EPA December 2001) is 10 µg/L (0.01 mg/L).
- Elevated concentration of chlorophyll a, excessive algal and macrophyte growth, and low levels of dissolved oxygen are all effects of nutrient enrichment. The relationship between these factors and high in-stream total phosphorus concentrations is well documented in scientific literature, including guidance developed by EPA to address nutrient over-enrichment (*Nutrient Criteria Technical Guidance Manual – Rivers and Streams*, EPA July 2000 [EPA-822-B-00-002]).

The effectiveness of the current average monthly total phosphorus limit of 1.0 mg/L in protecting the quality of the receiving water was evaluated by estimating the instream phosphorus concentration downstream of the discharge under critical flow conditions. The evaluation considered both current background phosphorus concentrations (C_s) as well as the reduction of upstream phosphorus loading expected when the Pittsfield WWTP, a significant upstream

discharger, completes implementation of its new total phosphorus effluent limit in 2022.¹²

The following mass balance is used to project critical in-stream total phosphorus concentrations downstream from the discharge.

$$Q_d C_d + Q_s C_s = Q_r C_r$$

Where:

Q_s	=	7Q10 flow upstream of Facility
Q_d	=	Effluent flow
Q_r	=	combined stream flow (7Q10 + effluent flow)
C_s	=	median upstream total phosphorus concentration
C_d	=	effluent total phosphorus concentration

Upstream samples collected in 2007 upstream of Lenox and Pittsfield are shown in Table 4. As the effective effluent limit at Pittsfield has not changed since 2007, this data continues to be representative of current conditions and provides a current median background concentration (C_s) of 0.11 mg/L total phosphorus upstream of Lenox.

Table 4: Housatonic River Instream Total Phosphorus Concentrations¹³ (mg/L)

Sample Date	04C (W-1104) Upstream of Lenox	04B (W-1105) Upstream of Pittsfield
5/8/2007	0.072	0.012
6/12/2007	0.091	0.030
7/17/2007	0.11	0.019
8/21/2007	0.18	0.022
9/25/2007	0.33	0.019
Median	0.11	0.019

To predict the 2022 background concentration upstream of Lenox, EPA used the 2007 data for station 04B and the future summertime effluent limit of 0.1 mg/L and solved the mass balance equation for the receiving water total phosphorus concentration downstream of the Pittsfield discharge (C_r) as follows:

$$C_r(\text{downstream of Pittsfield}) = \frac{Q_d C_d + Q_s C_s}{Q_r}$$

Where:

Q_s	=	7Q10 flow upstream of Pittsfield, 34.1 cfs
Q_d	=	13.2 cfs, based on the median of the August flows for 2014-2018, 8.5 MGD
Q_r	=	$Q_s + Q_d$, 47.3 cfs

¹² The Pittsfield WWTP will begin operating with a warm weather (April 1 – October 31) limit of 0.1 mg/L, and a cold weather (November 1 – March 31) limit of 1.0 mg/L in January, 2022.

¹³ Carr, Jamie, and Mitchell, Peter, MassDEP, Division of Watershed Management, 2013, “Technical Memorandum: Housatonic River Watershed 2007 DWM Water Quality Monitoring Data,” DWM Control Number CN 289.1.

$$\begin{aligned} C_s &= 0.019 \text{ mg/L} \\ C_d &= 0.1 \text{ mg/L} \end{aligned}$$

This yields C_r (downstream of Pittsfield) equal to 0.042 mg/L, estimating the concentration of phosphorus in the receiving water upstream of Lenox after the new effluent limits are implemented, assuming that most of the load upstream of Lenox is the direct result of Pittsfield's current discharges. It should be noted that this analysis does not include the likely potential for the recycling of accumulated phosphorus in Woods Pond sediments to continue providing a significant source of phosphorus in the Housatonic for years beyond the implementation of the new effluent limit at the Pittsfield WWTP.¹⁴ EPA is not aware of any efforts underway to measure or mitigate the likely flux of phosphorus from Woods Pond sediments into the Housatonic River. If the Woods Pond sediments are a significant portion of the in-stream phosphorus loading upstream of Lenox, then measurable improvements in the phosphorus concentrations there may not occur for many years beyond 2022.

Using the current and predicted upstream concentrations for C_s upstream of Lenox, 0.11 mg/L and 0.042 mg/L, the current and expected concentration of total phosphorus downstream of Lenox, if the effluent limit remains at 1.0 mg/L can be calculated as follows:

$$C_r(\text{downstream of Lenox}) = \frac{Q_d C_d + Q_s C_s}{Q_r}$$

Where:

$$\begin{aligned} Q_s &= 7Q10 \text{ flow upstream of Lenox, 40.0 cfs} \\ Q_d &= 1.84 \text{ cfs, based on the Lenox design flow of 1.19 MGD} \\ Q_r &= Q_s + Q_d, 41.84 \text{ cfs} \\ C_s &= 0.11 \text{ mg/L (current) or 0.042 mg/L (future)} \\ C_d &= 1.0 \text{ mg/L} \end{aligned}$$

This yields C_r (downstream of Lenox) of 0.15 mg/L under current conditions and 0.084 mg/L under future conditions. Therefore, under current or future upstream conditions, current effluent limit at Lenox of 1.0 mg/L would be expected to result in a downstream concentration which exceeds both the ecoregional criteria of 0.010 mg/L and the Gold Book criteria of 0.050 mg/L.

To determine the effluent limit that would result in meeting water quality standards, the mass balance equation can be solved for the effluent concentration, C_d , as follows:

$$C_d = \frac{Q_r C_r - Q_s C_s}{Q_d}$$

Where:

$$\begin{aligned} Q_r &= Q_s + Q_d, 41.84 \text{ cfs} \\ Q_s &= 7Q10 \text{ flow upstream of Lenox, 40.0 cfs} \end{aligned}$$

¹⁴ Sondergaard, Martin, et al, *Role of Sediment and Internal Loading of Phosphorus in Shallow Lakes*, *Hydrobiologia* 506-509, 2003, pages 135-145.

Q_d	=	1.84 cfs, based on the Lenox design flow of 1.19 MGD
C_r	=	0.050 mg/L (based on the Gold Book criteria)
C_s	=	0.11 mg/L (current) or 0.042 mg/L (future)

Due to the relatively low design flow of the Lenox facility and the high impact of the upstream phosphorus loading, this calculation yields a negative effluent concentration under current conditions and 0.22 mg/L under future conditions in order to meet Gold Book threshold of 0.050 mg/L.

While the current and future estimates clearly show that further reductions in phosphorus loading from Lenox are necessary to achieve water quality standards in Woods Pond, it is clear that the reductions in phosphorus loading upstream of Lenox are likely to greatly impact the conditions in Woods Pond. Therefore, the draft permit proposes an average monthly phosphorus limitation of 0.22 mg/L consistent with the effluent limit necessary to meet WQS following implementation of the planned upgrade at the Pittsfield WWTP. The draft permit proposes to maintain the cold weather (November 1 to March 31) total phosphorus limit of 1.0 mg/L. Total phosphorus sampling will continue to be weekly. In addition, the draft permit proposes seasonal monitoring of upstream phosphorus concentrations to ensure that sufficient information is available to evaluate the impact of the new effluent limit at Pittsfield and whether lower warm weather and/or cold weather effluent limits are warranted for Lenox when the permit is next reissued.

Schedules of compliance to meet water quality based effluent limits may be included in permits only when the state's water quality standards clearly authorize such schedules and where the limits are established to meet a water quality standard that is either newly adopted, revised, or interpreted after July 1, 1977. Massachusetts regulations for schedules of compliance can be found at 314 CMR 3.11(10). Finally, the permitting authority must make a reasonable determination that a schedule of compliance is "appropriate" and that compliance is required "as soon as possible." *See* 40 CFR § 122.47(a), § 122.47(a)(1).

Since the current Lenox WWTP will be unable to achieve the warm weather effluent limit of 0.22 mg/L without changes to the treatment process, the Draft Permit proposes a one-year schedule of compliance with an interim total phosphorus limit of 1.0 mg/L in the Draft Permit. A schedule of compliance to achieve 0.22 mg/L is detailed in the Draft Permit, Part I.G.2.

5.1.10 Metals

Dissolved fractions of certain metals in water can be toxic to aquatic life. Therefore, there is a need to limit toxic metal concentrations in the effluent where aquatic life may be impacted. For the development of the Draft Permit, analyses were completed to evaluate whether there is reasonable potential for effluent discharges to cause or contribute to exceedances of the water quality criteria for aluminum, cadmium, copper, lead, nickel and zinc and/or to evaluate whether any existing limits in the 2007 Permit for these metals continue to be protective, given the updated upstream hydrologic and chemical characteristics of the receiving water. The 2007 Permit included no metals effluent limits. A summary of recent metals compliance and monitoring results is provided in Appendix A.

5.1.10.1 Applicable Metals Criteria

State water quality criteria for cadmium, copper, lead, nickel and zinc are established in terms of dissolved metals. However, many inorganic components of domestic wastewater, including metals, are in particulate form, and differences in the chemical composition between the effluent and the receiving water affects the partitioning of metals between the particulate and dissolved fractions as the effluent mixes with the receiving water, often resulting in a transition from the particulate to dissolved form (*The Metals Translator: Guidance for Calculating a Total Recoverable Permit Limit from a Dissolved Criterion* (USEPA 1996 [EPA-823-B96-007])). Consequently, quantifying only the dissolved fraction of metals in the effluent prior to discharge may not accurately reflect the biologically-available portion of metals in the receiving water. Regulations at 40 C.F.R. § 122.45(c) require, with limited exceptions, that effluent limits for metals in NPDES permits be expressed as total recoverable metals.

Additionally, the criteria for cadmium, copper, lead, nickel and zinc are hardness-dependent using the equations in EPA's National Recommended Water Quality Criteria: 2002, which are incorporated into the Massachusetts WQS by reference. The estimated hardness of the Housatonic River downstream of the treatment plant during critical low flow periods and design discharge flow was calculated based on median ambient and effluent hardness data as reported in the Facility's whole effluent toxicity tests during the review period, using the mass balance equation discussed in the next section (substituting hardness for metal concentration). The resulting downstream hardness is 127.9 mg/L and the corresponding criteria are presented in Appendix B.

Massachusetts aluminum criteria are not hardness-dependent and are expressed as total recoverable aluminum.

5.1.10.2 Reasonable Potential Analysis and Limit Derivation

To determine whether the effluent has the reasonable potential to cause or contribute to an exceedance above the in-stream water quality criteria for each metal, the following mass balance is used to project in-stream metal concentrations downstream from the discharge.

$$Q_d C_d + Q_s C_s = Q_r C_r$$

Solving for the receiving water metal concentration downstream of the discharge (C_r) yields:

$$C_r = \frac{Q_d C_d + Q_s C_s}{Q_r}$$

Where:

Q_s	=	7Q10 flow upstream of Facility
Q_d	=	design flow of Facility
Q_r	=	combined stream flow (7Q10 + design flow)
C_s	=	median upstream metal concentration

$$C_d = \text{effluent metals concentration (95}^{\text{th}} \text{ percentile)}^{15}$$

Reasonable potential is then determined by comparing this resultant in-stream concentration (for both acute and chronic conditions) with the criteria for each metal. In EPA's Technical Support Document for Water Quality Based Toxics Control, EPA/505/2-90-001, March 1991, commonly known as the "TSD", box 3-2 describes the statistical approach in determining if there is reasonable potential for an excursion above the maximum allowable concentration. If there is reasonable potential (for either acute or chronic conditions), the appropriate limit is then calculated by rearranging the above mass balance to solve for the effluent concentration (C_d) using the criterion as the resultant in-stream concentration (C_r).

For metals with an existing limit in the 2007 Permit, a reasonable potential determination is not applicable, so the table indicates "N/A" for reasonable potential. In such cases, the same mass balance equation is used to determine if a more stringent limit would be required to meet WQS under current conditions. The limit is determined to be the more stringent of either (1) the existing limit or (2) the calculated effluent concentration (C_d) allowable to meet WQS based on current conditions.

Alternately, if the mass balance indicates that a less stringent effluent concentration (C_d) would meet WQS under current conditions, a case-by-case analysis must be done to determine if backsliding is allowable based on the exceptions found at 40 CFR § 122.44(l)(2)(i).

Estimate of Upstream Metal Concentrations

Since ambient upstream data was not available for Lenox, it was necessary to estimate the concentration of each metal in the Housatonic River upstream of the Lenox WWTP. The estimation was made by calculating the loading of each metal in the Housatonic River upstream of Lee during low flow conditions (using available concentration data there) and subtracting from that the effluent loading from Lenox (using effluent flow and concentration).

So, first the ambient loading upstream of Lenox was calculated as follows.

$$L_{ee}M_{amb} = L_{ee}C_{amb} \times L_{ee}Q_{amb} \times 8.34$$

where:

- $L_{ee}M_{amb}$ = Lee upstream ambient metal mass loading (lb/day)
- $L_{ee}C_{amb}$ = Lee ambient metal concentration (mg/L)
- $L_{ee}Q_{amb}$ = Lee 7Q10 flow = 25.1 MGD
- 8.34 = unit conversion factor

Then, the mass loading from Lenox was calculated as follows:

$$L_{en}M_{eff} = L_{en}C_{eff} \times L_{en}Q_{eff} \times 8.34$$

¹⁵ The Facility's effluent concentrations (from Appendix A) were characterized assuming a lognormal distribution to determine the estimated 95th percentile of the daily maximum (See Appendix B).x

where,

$$\begin{aligned} L_{en}M_{eff} &= \text{Lenox effluent metal mass loading (lb/day)} \\ L_{en}C_{eff} &= \text{Lenox 95}^{th} \text{ percentile effluent metal concentration (mg/L)} \\ L_{en}Q_{eff} &= \text{Lenox highest monthly effluent flow (during the 2014-2018 review period)} = \\ & 1.171 \text{ MGD} \end{aligned}$$

Then, the ambient mass loading in the river upstream of Lee was estimated as follows:

$$L_{en}M_{amb} = L_{ce}M_{amb} - L_{en}M_{eff}$$

where,

$$L_{en}M_{amb} = \text{Lenox upstream ambient metal mass loading (lb/day)}$$

Finally, the ambient concentration upstream of Lenox was estimated as follows:

$$L_{en}C_{amb} = L_{en}M_{amb} / (L_{en}Q_{amb} \times 8.34)$$

Where,

$$\begin{aligned} L_{en}C_{amb} &= \text{Lenox ambient metal concentration (mg/L)} \\ L_{en}Q_{amb} &= \text{Lenox 7Q10 flow} = 25.8 \text{ MGD} \end{aligned}$$

The results of this analysis for each metal are presented in Appendix B.

Results of Reasonable Potential Analysis

Based on the analysis described above, there was no reasonable potential identified for most of the metals to cause or contribute to a violation of water quality standards. The exception was for aluminum where the estimated upstream ambient concentration, 89 $\mu\text{g/L}$, was greater than the chronic water quality criteria, 87 $\mu\text{g/L}$.

In considering whether a permit limit for aluminum is warranted, EPA calculated the maximum upstream concentration at which no reasonable potential would be found for Lenox's discharge to cause or contribute to a violation of water quality standards.

Setting the downstream concentration to the aluminum criteria of 0.087 mg/L, the mass balance equation can be solved for the upstream phosphorus concentration, C_s , to see if this is a reasonable expectation, as follows:

$$C_s = \frac{Q_r C_r - Q_d C_d}{Q_s}$$

Where:

$$\begin{aligned} Q_s &= 7Q10 \text{ flow upstream of Lenox, 40.0 cfs} \\ Q_d &= 1.84 \text{ cfs, based on the Lenox design flow of 1.19 MGD} \\ Q_r &= Q_s + Q_d = 41.84 \text{ cfs} \\ C_r &= 0.087 \text{ mg/L} \end{aligned}$$

$$C_d = 0.266 \text{ mg/L}$$

This calculation shows that there would be no reasonable potential if the upstream concentration were 0.079 mg/L or less.

Permit Requirements

Given the limited data available and the likely margin of error associated with the estimation of the upstream ambient aluminum concentration, the Draft Permit proposes monthly aluminum monitoring rather than an effluent limit at this time. The monthly monitoring data, combined with the semi-annual upstream monitoring data which will be collected as part of the WET testing, will be used to reevaluate the need for an aluminum effluent limit in the next permit reissuance.

5.1.11 Whole Effluent Toxicity

Sections 402(a)(2) and 308(a) of the CWA provide EPA and States with the authority to require toxicity testing. Section 308 specifically describes biological monitoring methods as techniques that may be used to carry out objectives of the CWA. Whole effluent toxicity (WET) testing is conducted to ensure that the additivity, antagonism, synergism and persistence of the pollutants in the discharge do not cause toxicity, even when the pollutants are present at low concentrations in the effluent. The inclusion of WET requirements in the Draft Permit will assure that the Facility does not discharge combinations of pollutants into the receiving water in amounts that would affect aquatic life or human health.

In addition, under § 301(b)(1)(C) of the CWA, discharges are subject to effluent limitations based on WQSs. Under certain narrative State WQSs, and §§ 301, 303 and 402 of the CWA, EPA and the States may establish toxicity-based limitations to implement the narrative “no toxics in toxic amounts”. The Massachusetts WQSs at 314 CMR 4.05(5)(e) state, “*All surface waters shall be free from pollutants in concentrations or combinations that are toxic to humans, aquatic life or wildlife.*”

National studies conducted by the EPA have demonstrated that domestic sources, as well as industrial sources, contribute toxic constituents to POTWs. These constituents include metals, chlorinated solvents, aromatic hydrocarbons and others. Some of these constituents may cause synergistic effects, even if they are present in low concentrations. Because of the source variability and contribution of toxic constituents in domestic and industrial sources, EPA assumes that there is a reasonable potential for this discharge to cause or contribute to an exceedance of the “no toxics in toxic amounts” narrative water quality standard.

Further, EPA Region 1 and MassDEP¹⁶ current toxic policies require toxicity testing for all dischargers such as the Lenox WWTP. In accordance with these policies, whole effluent chronic effects are regulated by limiting the highest measured continuous concentration of an effluent that causes no observed chronic effect on a representative standard test organism, known as the

¹⁶ Implementation Policy for the Control of Toxic Pollutants in Surface Waters, MassDEP 1990

chronic No Observed Effect Concentration (C-NOEC). Whole effluent acute effects are regulated by limiting the concentration that is lethal to 50% of the test organisms, known as the LC₅₀.

The acute WET limit in the 2007 Permit is LC₅₀ greater than or equal to 100%, using the daphnid, *Ceriodaphnia dubia* (*C. dubia*), as the test species. The Facility has consistently met these limits, as can be seen from the DMR summary in Appendix A. It is noted that as part of the 2007 permit issuance, EPA eliminated the required testing for the fathead minnow (*Pimephales promelas*) based on WET Testing results as *Ceriodaphnia dubia* was found to be the more sensitive species.

Based on the potential for toxicity from domestic and industrial contributions, the state narrative water quality criterion, the dilution factor of 22.7, and in accordance with EPA national and regional policy and 40 C.F.R. § 122.44(d), the Draft Permit continues the effluent limits from the 2007 Permit including the test organism and the testing frequency. Toxicity testing must be performed in accordance with the updated EPA Region 1 WET Test Procedures and Protocols specified in Attachment A of the Draft Permit (USEPA Region 1 Freshwater Acute Toxicity Test Procedure and Protocol, February 2011).

5.2 Industrial Pretreatment Program

The permittee is required to identify, in terms of the character and volume of pollutants, any significant industrial users to the POTW subject to pretreatment standards under Section 307(b) of the CWA and 40 CFR Part 403.

5.3 Sludge Conditions

Section 405(d) of the Clean Water Act requires that EPA develop technical standards regarding the use and disposal of sewage sludge. On February 19, 1993, EPA promulgated technical standards. These standards are required to be implemented through permits. The conditions in the permit satisfy this requirement.

5.4 Infiltration/Inflow (I/I)

Infiltration is groundwater that enters the collection system through physical defects such as cracked pipes, or deteriorated joints. Inflow is extraneous flow entering the collection system through point sources such as roof leaders, yard and area drains, sump pumps, manhole covers, tide gates, and cross connections from storm water systems. Significant I/I in a collection system may displace sanitary flow, reducing the capacity and the efficiency of the treatment works and may cause bypasses to secondary treatment. It greatly increases the potential for sanitary sewer overflows (SSOs) in separate systems, and combined sewer overflows (CSOs) in combined systems.

The Draft Permit includes a requirement for the permittee to control infiltration and inflow (I/I) within the sewer collections system it owns and operates. The permittee shall develop an I/I removal program commensurate with the severity of I/I in the collection system. This program may be scaled down in sections of the collection system that have minimal I/I.

5.5 Operation and Maintenance of the Sewer System

The standard permit conditions for ‘Proper Operation and Maintenance’, found at 40 C.F.R. § 122.41(e), require the proper operation and maintenance of permitted wastewater systems and related facilities to achieve permit conditions. The requirements at 40 C.F.R. § 122.41(d) impose a ‘duty to mitigate’ upon the permittee, which requires that “all reasonable steps be taken to minimize or prevent any discharge violation of the permit that has a reasonable likelihood of adversity affecting human health or the environment. EPA and MassDEP maintain that an I/I removal program is an integral component of ensuring permit compliance with the requirements of the permit under the provisions at 40 C.F.R. § 122.41(d) and (e).

General requirements for proper operation and maintenance, and mitigation have been included in Part II of the permit. Specific permit conditions have also been included in Part I.C. and I.D. of the Draft Permit. These requirements include mapping of the wastewater collection system, preparing and implementing a collection system operation and maintenance plan, reporting of unauthorized discharges including SSOs, maintaining an adequate maintenance staff, performing preventative maintenance, controlling inflow and infiltration to separate sewer collection systems (combined systems are not subject to I/I requirements) to the extent necessary to prevent SSOs and I/I related effluent violations at the Wastewater Treatment Facility and maintaining alternate power where necessary. These requirements are included to minimize the occurrence of permit violations that have a reasonable likelihood of adversely affecting human health or the environment.

Several of the requirements in the Draft Permit are not included in the 2007 Permit, including collection system mapping, and preparation of a collection system operation and maintenance plan. EPA has determined that these additional requirements are necessary to ensure the proper operation and maintenance of the collection system and has included schedules for completing these requirements in the Draft Permit.

5.6 Standard Conditions

The standard conditions of the permit are based on 40 C.F.R. §122, Subparts A, C, and D and 40 C.F.R. § 124, Subparts A, D, E, and F and are consistent with management requirements common to other permits.

6 Federal Permitting Requirements

6.1 Endangered Species Act

Section 7(a) of the Endangered Species Act of 1973, as amended (ESA), grants authority and imposes requirements on Federal agencies regarding endangered or threatened species of fish, wildlife, or plants (listed species) and habitat of such species that has been designated as critical (a “critical habitat”).

Section 7(a)(2) of the ESA requires every Federal agency, in consultation with and with the assurance of the Secretary of Interior, to ensure that any action it authorizes, funds or carries out, in the United States or upon the high seas, is not likely to jeopardize the continued existence of

any listed species or result in the destruction or adverse modification of critical habitat. The United States Fish and Wildlife Service (USFWS) administers Section 7 consultations for freshwater species. The National Marine Fisheries Service (NMFS) administers Section 7 consultations for marine and anadromous species.

The Federal action being considered in this case is EPA's proposed NPDES permit for the Facility. The Draft Permit is intended to replace the 2007 Permit in governing the Facility. Specifically, the Draft Permit proposes to regulate the discharge from Outfall 001, located at Latitude 42°20'56" N, Longitude -73°14'43" W, on the west bank of the Housatonic River in Lenox, Massachusetts.

As the federal agency charged with authorizing the discharge from this Facility, EPA determines potential impacts to federally listed species, and initiates consultation, when required under § 7(a)(2) of the ESA.

EPA has reviewed the federal endangered or threatened species of fish, wildlife, and plants in the expected action area to determine if EPA's proposed NPDES permit could potentially impact any such listed species. One species under the jurisdiction of the USFWS was identified, namely the federally listed northern long-eared bat (*Myotis septentrionalis*). This terrestrial animal species is classified as threatened.¹⁷ According to the USFWS, the northern long-eared bat is found in "winter - mines and caves, summer - wide variety of forested habitats." This species is not aquatic, so the discharge will have no direct effect on this mammal. Further, the permit action is also expected to have no indirect effect on the species because it is not expected to impact insects, the primary prey of the northern long-eared bat. Therefore, the proposed permit action is deemed to have no impact on this listed species.

In addition, two anadromous fish species under the jurisdiction of NMFS occur in Massachusetts waters, the shortnose sturgeon (*Acipenser brevirostrum*) and Atlantic sturgeon (*Acipenser oxyrinchus*), classified as threatened and/or endangered.¹⁸ In general, these fish are not expected to be present upstream of the Derby Dam in Derby, Connecticut. The action area is approximately 101 river miles upstream of this dam. Based on the expected normal distribution of these species, it is highly unlikely that they would be present in the vicinity of this discharge and the action area of the outfall. Therefore, the proposed permit action will have no impact on these listed anadromous fish species.

Based on the above review, EPA finds that adoption of the proposed permit will have no effect on any threatened or endangered species or their designated critical habitat. Therefore, consultation with NMFS or USFWS under Section 7 of the ESA is not required.

6.2 Essential Fish Habitat

Under the 1996 Amendments (PL 104-267) to the Magnuson-Stevens Fishery Conservation and Management Act (*see* 16 U.S.C. § 1801 *et seq.*, 1998), EPA is required to consult with the

¹⁷ See Section 7 resources for USFWS at <https://ecos.fws.gov/ipac/>

¹⁸ See Section 7 resources for NMFS at <https://www.greateratlantic.fisheries.noaa.gov/protected/section7/index.html>

National Marine Fisheries Service (NMFS) if EPA's action or proposed actions that it funds, permits, or undertakes, "may adversely impact any essential fish habitat". *See* 16 U.S.C. § 1855(b).

The Amendments broadly define "essential fish habitat" (EFH) as: "waters and substrate necessary to fish for spawning, breeding, feeding, or growth to maturity". *See* 16 U.S.C. § 1802(10). "Adverse impact" means any impact that reduces the quality and/or quantity of EFH, 50 C.F.R. § 600.910(a). Adverse effects may include direct (e.g., contamination or physical disruption), indirect (e.g., loss of prey, reduction in species' fecundity), site specific or habitat-wide impacts, including individual, cumulative, or synergistic consequences of actions.

EFH is only designated for fish species for which federal Fisheries Management Plans exist. *See* 16 U.S.C. § 1855(b)(1)(A). EFH designations for New England were approved by the U.S. Department of Commerce on March 3, 1999.

The Housatonic River is not covered by any EFH designation for riverine systems and thus EPA has determined that consultation with NMFS Habitat Conservation Division is not required.

7 Public Comments, Hearing Requests and Permit Appeals

All persons, including applicants, who believe any condition of the Draft Permit is inappropriate must raise all issues and submit all available arguments and all supporting material for their arguments in full by the close of the public comment period by mail or email, to

Robin L. Johnson
EPA New England, Region 1
5 Post Office Square, Suite-100 (06-1)
Boston, MA 02109-3912
or via email to johnson.rob@epa.gov
and

Jennifer Wood
Surface Water Discharge Program
MassDEP
One Winter Street, 5th Floor
Boston, MA 02108
or via email to jennifer.wood@mass.gov

Any person, prior to the close of the public comment period, may submit a request in writing for a public hearing to consider the Draft Permit to EPA and the State Agency. Such requests shall state the nature of the issues proposed to be raised in the hearing. A public meeting may be held if the criteria stated in 40 C.F.R. § 124.12 are satisfied. In reaching a final decision on the Draft Permit, the EPA will respond to all significant comments and make these responses available to the public at EPA's Boston office.

Following the close of the comment period, and after any public hearings, if such hearings are held, the EPA will issue a Final Permit decision, forward a copy of the final decision to the

applicant, and provide a copy or notice of availability of the final decision to each person who has submitted written comments or requested notice. Within 30 days following the notice of the Final Permit decision, any interested person may submit a petition for review of the permit to EPA's Environmental Appeals Board consistent with 40 C.F.R. § 124.19 and/or submit a request for an adjudicatory hearing to MassDEP's Office of Appeals and Dispute Resolution consistent with 310 CMR 1.00.

8 EPA Contact

The administrative record on which this Draft Permit is based may be obtained between the hours of 9:00 a.m. and 5:00 p.m., Monday through Friday, excluding holidays from:

Robin L. Johnson
EPA New England, Region 1
5 Post Office Square, Suite-100 (06-1)
Boston, MA 02109-3912
Telephone: (617) 918-1045, FAX: (617) 918-0045
Email: johnson.robins@epa.gov

June 21, 2019

Date

Ken Moraff, Director
Water Division
U.S. Environmental Protection Agency

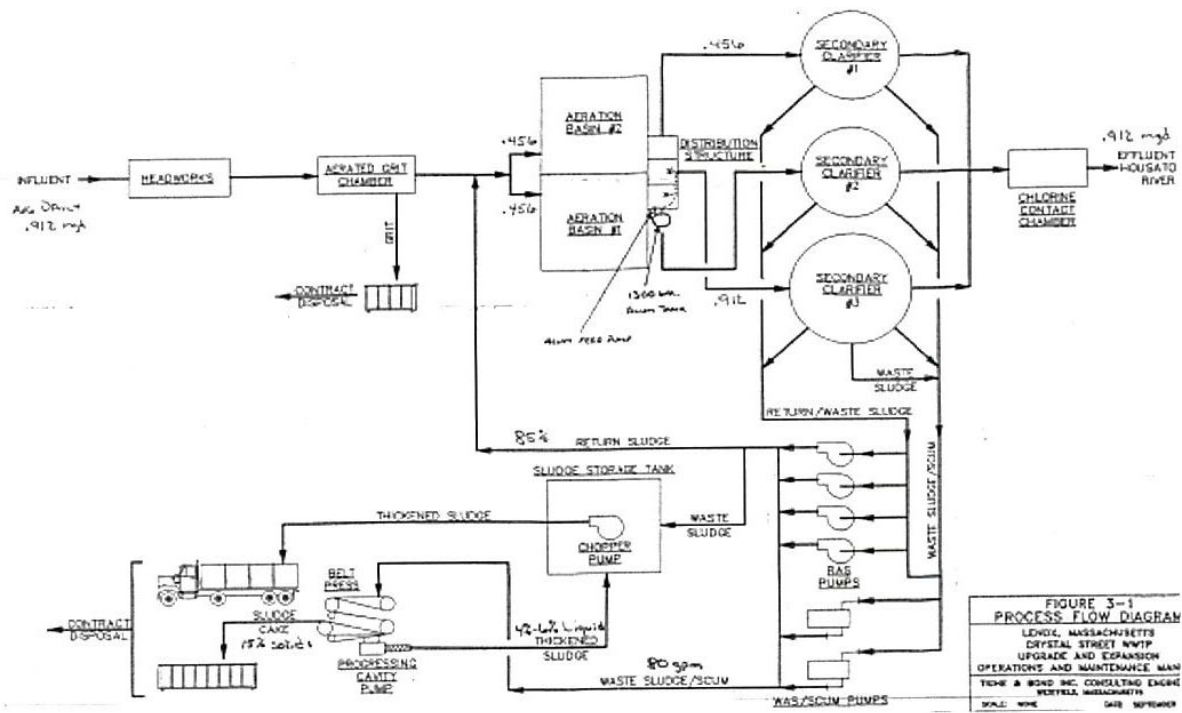

Figure 2 Lenox WWTP Process Flow Schematic

APPENDIX A - DISCHARGE MONITORING REPORT (DMR) SUMMARY

Parameter	Flow, total	Flow	Flow	BOD5	BOD5	BOD5
	Annual Ave	Monthly Ave	Daily Max	Monthly Ave	Monthly Ave	Weekly Ave
Units	MGD	MGD	MGD	lb/d	mg/L	lb/d
Effluent Limit	1.19	Report	Report	300	30	450
Minimum	0.598	0.321	0.395	8.3	3.1	8.9
Maximum	0.755	1.171	2.891	49.1	10.8	104.2
Average	0.675	0.619	1.12	21.8	4.13	31.6
No. of Violations	0	N/A	N/A	0	0	0
1/31/2014	0.678	0.634	1.056	36	5.6	53.5
2/28/2014	0.656	0.368	0.627	9.9	3.8	11.4
3/31/2014	0.678	0.631	2.436	31.8	10.8	45
4/30/2014	0.701	0.91	1.429	25.3	3.1	28.5
5/31/2014	0.684	0.707	1.578	17.6	3.4	21.6
6/30/2014	0.684	0.713	2.349	18.4	3.5	28.2
7/31/2014	0.704	0.945	2.485	27.2	3.6	44.1
8/31/2014	0.679	0.645	1.139	24.5	3.5	56.5
9/30/2014	0.651	0.321	0.399	13.8	3.1	36.6
10/31/2014	0.655	0.362	0.851	8.3	3.3	8.9
11/30/2014	0.652	0.406	0.516	11.4	3.5	12.6
12/31/2014	0.705	0.959	2.891	35.3	3.6	86.8
1/31/2015	0.673	0.582	0.955	21.2	3.6	27.8
2/28/2015	0.631	0.345	0.395	12.2	4	15.1
3/31/2015	0.666	0.487	1.068	12.8	3.7	16.5
4/30/2015	0.723	1.171	1.944	31.6	4.1	43.2
5/31/2015	0.673	0.455	0.623	21.8	5.4	27.2
6/30/2015	0.673	0.682	1.57	22	4.1	27.6
7/31/2015	0.673	0.525	0.794	16.9	3.8	18.7
8/31/2015	0.658	0.393	0.661	12.1	3.9	14.3
9/30/2015	0.658	0.393	0.661	12.1	3.9	14.3
10/31/2015	0.658	0.393	0.624	13.5	3.8	19.8
11/30/2015	0.663	0.451	0.643	14.9	3.9	19.7
12/31/2015	0.668	0.542	0.83	13.2	3.1	15.1
1/31/2016	0.674	0.585	0.783	17.2	3.5	18.1
2/29/2016	0.682	0.686	1.204	27.6	4.7	61
3/31/2016	0.685	0.717	0.942	31.2	3.2	68.7
4/30/2016	0.684	0.707	1.034	21.5	3.8	31.1
5/31/2016	0.674	0.589	0.946	16	4.1	19.5
6/30/2016	0.677	0.621	0.901	21.3	3.8	25.6
7/31/2016	0.668	0.506	0.6	18	4.4	23.2
8/31/2016	0.664	0.471	0.602	21.6	5.9	28.6
9/30/2016	0.654	0.374	0.474	11.8	3.7	13.4
10/31/2016	0.656	0.376	0.57	10.3	3.6	11.9
11/30/2016	0.66	0.424	0.636	12.9	3.9	14.3
12/31/2016	0.673	0.712	1.615	23.3	4.1	31.9

APPENDIX A - DISCHARGE MONITORING REPORT (DMR) SUMMARY

Parameter	Flow, total	Flow	Flow	BOD5	BOD5	BOD5
	Annual Ave	Monthly Ave	Daily Max	Monthly Ave	Monthly Ave	Weekly Ave
Units	MGD	MGD	MGD	lb/d	mg/L	lb/d
Effluent Limit	1.19	Report	Report	300	30	450
1/31/2017	0.674	0.714	0.901	23.5	3.9	29.1
2/28/2017	0.686	0.73	1.176	14.7	3.7	21.4
3/31/2017	0.695	0.733	1.1471	25	3.9	37.9
4/30/2017	0.722	0.977	1.743	27.9	3.8	33.8
5/31/2017	0.724	0.806	1.087	27.3	3.8	35.6
6/30/2017	0.722	0.65	0.983	27.3	3.5	59.5
7/31/2017	0.719	0.575	0.716	15.9	3.8	17.6
8/31/2017	0.654	0.488	0.571	21.5	4.9	27.5
9/30/2017	0.624	0.436	0.612	15.7	4	17.2
10/31/2017	0.612	0.405	0.96	11.8	3.7	12.4
11/30/2017	0.605	0.454	0.509	16.8	4	24.4
12/31/2017	0.598	0.46	0.592	14.5	3.8	15.8
1/31/2018	0.622	0.746	1.984	25.5	4.5	29.5
2/28/2018	0.66	0.912	1.461	26.2	3.7	35.9
3/31/2018	0.731	0.898	1.375	31.6	4.6	38.6
4/30/2018	0.684	0.376	0.57	40.3	5.2	49.7
5/31/2018	0.726	0.619	0.888	39.3	7.4	46.8
6/30/2018	0.716	0.497	0.847	12.6	3.1	15.4
7/31/2018	0.653	0.522	0.684	17.6	4.1	22.8
8/31/2018	0.65	0.766	1.908	23	4	27.6
9/30/2018	0.665	0.723	1.62	22.8	4	35
10/31/2018	0.688	0.812	1.646	33.6	3.6	50.8
11/30/2018	0.735	1.103	2.423	49.1	5.1	65.3
12/31/2018	0.755	0.932	1.887	48.3	4.8	104.2

APPENDIX A - DISCHARGE MONITORING REPORT (DMR) SUMMARY

Parameter	BOD5		BOD5	TSS		TSS	TSS
	Weekly Ave	Daily Max	Monthly Ave	Monthly Ave	Monthly Ave	Weekly Ave	Weekly Ave
Units	mg/L	mg/L	% Removal	lb/d	mg/L	lb/d	mg/L
Effluent Limit	45	Report	85%	300	30	450	45
Minimum	3.3	3.3	91%	2.4	0.4	3.4	0.6
Maximum	11.3	11.3	99%	151.9	19.8	262.1	32
Average	4.7	4.7	97%	19.7	3.48	32.9	5.54
No. of Violations	0	N/A	0	0	0	0	0
1/31/2014	8.2	8.2	94%	45.1	7.1	60.7	9.3
2/28/2014	4.3	4.3	97%	4.5	1.8	6.3	2.7
3/31/2014	11.3	11.3	91%	22.6	5.8	32.4	6.7
4/30/2014	3.3	3.3	97%	21.1	2.7	32.5	5.1
5/31/2014	4	4	98%	17.4	3.6	23.4	6
6/30/2014	4.3	4.3	96%	14	2.7	20	3
7/31/2014	4.3	4.3	96%	13.8	2	19.9	3.3
8/31/2014	4	4	97%	7.4	1.8	11.6	2.7
9/30/2014	3.3	3.3	98%	4.6	1.8	9.3	3.8
10/31/2014	3.6	3.6	98%	3.2	1.3	5.1	2.1
11/30/2014	3.8	3.8	97%	5.4	1.5	8.1	2
12/31/2014	3.8	3.8	97%	31.3	2.6	65.1	5
1/31/2015	3.9	3.9	97%	8.4	1.6	16	2.6
2/28/2015	4.7	4.7	97%	3.9	1.4	5.5	2.2
3/31/2015	3.9	3.9	97%	8.4	2.5	10.1	3.2
4/30/2015	4.9	4.9	95%	25.3	3.1	55.4	6
5/31/2015	7.2	7.2	97%	13	3.5	15.7	4.6
6/30/2015	4.9	4.9	97%	16.9	2.8	30.5	4.5
7/31/2015	4	4	98%	9.2	1.8	19.2	2.9
8/31/2015	4.3	4.3	98%	7.8	2.5	14.3	4.3
9/30/2015	4.3	4.3	98%	7.8	2.5	14.3	4.3
10/31/2015	4.1	4.1	98%	4.7	1.7	6.4	2.6
11/30/2015	4.2	4.2	98%	7.5	2	8.4	2.6
12/31/2015	3.4	3.4	98%	4.2	1	8.8	1.6
1/31/2016	3.8	3.8	97%	7.5	1.8	21.6	5.3
2/29/2016	7.2	7.2	96%	16.6	2.5	37.3	4.4
3/31/2016	3.4	3.4	97%	14.2	2.3	29.5	4.2
4/30/2016	3.9	3.9	97%	7.6	1.3	10.4	2
5/31/2016	5.4	5.4	98%	19.4	4.1	27.6	5.4
6/30/2016	3.8	3.8	96%	6.8	1.4	11.8	2.4
7/31/2016	5	5	98%	7.6	1.9	12.1	2.9
8/31/2016	8	8	98%	8.5	1.7	26.6	6.4
9/30/2016	4	4	98%	14.9	4.8	21.7	7.4
10/31/2016	3.7	3.7	98%	10.3	3.5	11.9	3.7
11/30/2016	4.2	4.2	98%	10.1	2.7	19.7	5.5
12/31/2016	4.9	4.9	97%	5.7	1.1	9.7	2.2

APPENDIX A - DISCHARGE MONITORING REPORT (DMR) SUMMARY

Parameter	BOD5	BOD5	BOD5	TSS	TSS	TSS	TSS
	Weekly Ave	Daily Max	Monthly Ave	Monthly Ave	Monthly Ave	Weekly Ave	Weekly Ave
Units	mg/L	mg/L	% Removal	lb/d	mg/L	lb/d	mg/L
Effluent Limit	45	Report	85%	300	30	450	45
1/31/2017	3.9	3.9	97%	2.4	0.4	3.4	0.6
2/28/2017	3.8	3.8	97%	15.9	3	32.4	5.8
3/31/2017	4.4	4.4	96%	7.8	1.2	11.9	2.5
4/30/2017	4.3	4.3	97%	12.4	2	23.6	3.7
5/31/2017	4	4	96%	11	1.5	19.6	2.2
6/30/2017	4.3	4.3	98%	25.2	5.1	54	12
7/31/2017	3.8	3.8	96%	9.3	2.1	14.6	3.4
8/31/2017	5.9	5.9	97%	9.4	2.4	19.1	5.1
9/30/2017	4.7	4.7	97%	5.4	1.6	21.2	4.7
10/31/2017	4	4	96%	4.8	1.5	13.9	4.2
11/30/2017	4.6	4.6	97%	5.4	1.4	12.2	2.9
12/31/2017	3.9	3.9	98%	17.2	4.4	31	8.5
1/31/2018	5	5	98%	22.6	4.2	31.5	5.6
2/28/2018	3.8	3.8	96%	32.4	4.2	52.9	5.6
3/31/2018	5.8	5.8	96%	16.3	2.6	20	3.5
4/30/2018	6	6	96%	151.9	19.8	262.1	32
5/31/2018	8.7	8.7	97%	37.9	7	49	11
6/30/2018	3.7	3.7	99%	40.2	10.9	46.1	12
7/31/2018	4.6	4.6	98%	38.7	8.4	57	10
8/31/2018	4.2	4.2	97%	42.4	7.9	59.2	13
9/30/2018	4.2	4.2	97%	33.6	5	46.1	6
10/31/2018	3.7	3.7	97%	53.3	6.6	109.8	9.5
11/30/2018	5.6	5.6	95%	105.1	9.1	154.3	13.5
12/31/2018	5.5	5.5	97%	44.6	6.1	89.1	10

APPENDIX A - DISCHARGE MONITORING REPORT (DMR) SUMMARY

Parameter	TSS	TSS	pH	pH	E. coli	E. coli	TRC
	Daily Max	Monthly Ave	Minimum	Maximum	Daily Max	MOAV GEO	Monthly Ave
Units	mg/L	% Removal	SU	SU	CFU/100mL	CFU/100mL	mg/L
Effluent Limit	Report	85%	6.5	8.3	409	126	0.23
Minimum	0.6	70%	7	7.6	1	1	0.18
Maximum	32	100%	7.6	7.8	1732.9	32.7	0.22
Average	5.54	97%	7.34	7.68	92.3	6.92	0.201
No. of Violations	N/A	1	0	0	1	0	0
1/31/2014	9.3	87%	7	7.6			
2/28/2014	2.7	98%	7.3	7.6			
3/31/2014	6.7	97%	7.2	7.7			
4/30/2014	5.1	95%	7.3	7.8	1732.9	32.6	0.19
5/31/2014	6	97%	7.5	7.8	34.1	2.9	0.19
6/30/2014	3	99%	7.5	7.7	14.8	2	0.2
7/31/2014	3.3	98%	7.4	7.7	10.9	2.1	0.2
8/31/2014	2.7	98%	7.4	7.7	2	1.4	0.2
9/30/2014	3.8	98%	7	7.7	41.6	4.2	0.19
10/31/2014	2.1	99%	7.2	7.6	98.9	32.7	0.2
11/30/2014	2	99%	7.3	7.6			
12/31/2014	5	98%	7.3	7.8			
1/31/2015	2.6	99%	7.4	7.7			
2/28/2015	2.2	98%	7.5	7.7			
3/31/2015	3.2	98%	7.4	7.7			
4/30/2015	6	96%	7.4	7.7	46.4	5	0.2
5/31/2015	4.6	96%	7.4	7.7	193.5	5.3	0.19
6/30/2015	4.5	96%	7.1	7.6	9.6	2.8	0.21
7/31/2015	2.9	99%	7.3	7.6	18.3	7.77	0.21
8/31/2015	4.3	99%	7	7.6	6.3	4	0.22
9/30/2015	4.3	99%	7	7.6	6.3	4	0.22
10/31/2015	2.6	99%	7.3	7.6	32	5.08	0.21
11/30/2015	2.6	99%	7.4	7.6			
12/31/2015	1.6	99%	7.5	7.7			
1/31/2016	5.3	98%	7	7.7			
2/29/2016	4.4	98%	7.2	7.6			
3/31/2016	4.2	98%	7.3	7.7			
4/30/2016	2	99%	7.3	7.7	20.1	6.4	0.21
5/31/2016	5.4	97%	7.3	7.6	37.9	3.3	0.21
6/30/2016	2.4	99%	7	7.6	43.1	4.1	0.21
7/31/2016	2.9	99%	7.1	7.7	68.3	12.4	0.2
8/31/2016	6.4	99%	7.2	7.7	7.4	1.4	0.21
9/30/2016	7.4	97%	7.5	7.7	38.8	6.77	0.21
10/31/2016	3.7	98%	7.5	7.7	38	6.8	0.2
11/30/2016	5.5	99%	7.4	7.7			
12/31/2016	2.2	99%	7.4	7.7			

APPENDIX A - DISCHARGE MONITORING REPORT (DMR) SUMMARY

Parameter	TSS	TSS	pH	pH	E. coli	E. coli	TRC
	Daily Max	Monthly Ave	Minimum	Maximum	Daily Max	MOAV GEO	Monthly Ave
Units	mg/L	% Removal	SU	SU	CFU/100mL	CFU/100mL	mg/L
Effluent Limit	Report	85%	6.5	8.3	409	126	0.23
1/31/2017	0.6	100%	7.5	7.7			
2/28/2017	5.8	98%	7.6	7.7			
3/31/2017	2.5	99%	7.4	7.7			
4/30/2017	3.7	98%	7.6	7.7	2.1	3.5	0.21
5/31/2017	2.2	98%	7.6	7.7	1	1	0.21
6/30/2017	12	98%	7.2	7.7	1	1	0.2
7/31/2017	3.4	98%	7.6	7.7	22.8	4.13	0.19
8/31/2017	5.1	99%	7.6	7.7	8.5	2.6	0.2
9/30/2017	4.7	99%	7.5	7.7	7.5	5.9	0.19
10/31/2017	4.2	99%	7	7.7	30.5	4.1	0.2
11/30/2017	2.9	99%	7.5	7.7			
12/31/2017	8.5	99%	7.5	7.8			
1/31/2018	5.6	98%	7.4	7.7			
2/28/2018	5.6	98%	7.4	7.7			
3/31/2018	3.5	96%	7.3	7.6			
4/30/2018	32	70%	7.5	7.7	123.8	6.8	0.2
5/31/2018	11	95%	7.6	7.7	122.8	11.8	0.19
6/30/2018	12	96%	7.4	7.6	67.7	4.3	0.2
7/31/2018	10	92%	7.4	7.7	172.3	8	0.2
8/31/2018	13	94%	7.4	7.7	83	7.1	0.2
9/30/2018	6	97%	7.3	7.6	83	27.4	0.2
10/31/2018	9.5	93%	7.3	7.7	4.1	1.4	0.18
11/30/2018	13.5	85%	7.3	7.6			
12/31/2018	10	95%	7.4	7.6			

APPENDIX A - DISCHARGE MONITORING REPORT (DMR) SUMMARY

Parameter	TRC	Ammonia	TKN	Nitrate	Nitrite	TP
	Daily Max	Monthly Ave	Monthly Ave	Monthly Ave	Monthly Ave	Monthly Ave
Units	mg/L	mg/L	mg/L	mg/L	mg/L	mg/L
Effluent Limit	0.4	Report	Report	Report	Report	1
Minimum	0.21	0.07	0	0.12	0.001	0.04
Maximum	0.31	6.8	8.5	32.4	1.3	0.53
Average	0.246	0.575	1.53	12.3	0.138	0.202
No. of Violations	0	N/A	N/A	N/A	N/A	0
1/31/2014		0.18	2.1	5.8	0.01	0.22
2/28/2014		0.75	1.6	0.4	0.13	0.19
3/31/2014		3.1	4.9	0.53	0.4	0.27
4/30/2014	0.31	1.4	2.1	1.9	1.3	0.04
5/31/2014	0.25	6.4	8	0.22	0.24	
6/30/2014	0.23	0.78	4.9	4.2	1.2	
7/31/2014	0.25	0.16	0	15	0.15	
8/31/2014	0.25	0.088	0	8.3	0.036	
9/30/2014	0.25	0.12	0	24	0.11	
10/31/2014	0.25	6.8	8.5	3.1	0.26	
11/30/2014		0.22	0	17	0.024	0.21
12/31/2014		0.18	0.91	3.2	0.036	0.16
1/31/2015		0.14	0	7.6	0.047	0.17
2/28/2015		0.18	0	16	0.053	0.22
3/31/2015		0.28	0	16	0.3	0.2
4/30/2015	0.3	0.14	0.78	6.3	0.34	0.09
5/31/2015	0.27	2.2	3.6	1	0.14	0.13
6/30/2015	0.25	0.098	1	14	0.034	0.16
7/31/2015	0.25	0.12	2	24	0.04	0.17
8/31/2015	0.26	0.12	2	24	0.043	0.53
9/30/2015	0.26	0.12	2	24	0.043	0.21
10/31/2015	0.26	0.084	0.001	22	0.045	
11/30/2015		0.077	2.9	9.9	0.025	0.16
12/31/2015		0.14	0.0001	17	0.063	0.14
1/31/2016		0.07	2.2	9.7	0.018	0.09
2/29/2016		0.08	0	13	0.11	0.14
3/31/2016		0.71	1.4	6.4	0.49	0.14
4/30/2016	0.25	0.12	0.001	9.3	0.098	0.15
5/31/2016	0.25	2.7	2.9	0.25	0.067	0.16
6/30/2016	0.25	0.075	0.001	7.6	0.001	0.21
7/31/2016	0.25	0.085	0.01	6.1	0.054	0.21
8/31/2016	0.25	0.15	NODI: B	19	0.03	0.22
9/30/2016	0.25	0.2	NODI: B	32	0.11	
10/31/2016	0.22	0.16	NODI: B	30	0.077	
11/30/2016		0.12	NODI: B	16	0.031	0.11
12/31/2016		0.11	NODI: B	11	0.013	0.1

APPENDIX A - DISCHARGE MONITORING REPORT (DMR) SUMMARY

Parameter	TRC	Ammonia	TKN	Nitrate	Nitrite	TP
	Daily Max	Monthly Ave	Monthly Ave	Monthly Ave	Monthly Ave	Monthly Ave
Units	mg/L	mg/L	mg/L	mg/L	mg/L	mg/L
Effluent Limit	0.4	Report	Report	Report	Report	1
1/31/2017		0.097	NODI: B	10	NODI: B	0.22
2/28/2017		0.074	0.017	14	NODI: B	0.21
3/31/2017		0.247	0.5	9.14	0.126	0.07
4/30/2017	0.25	0.911	1.18	4.59	0.458	0.09
5/31/2017	0.23	0.282	1	9.65	0.0268	0.13
6/30/2017	0.25	1.36	1.45	0.12	0.0184	0.20
7/31/2017	0.24	0.23	2	32.4	0.0374	0.29
8/31/2017	0.23	0.127	1.16	23.1	0.293	0.32
9/30/2017	0.21	0.132	1.45	10	0.0431	
10/31/2017	0.25	0.0785	2	23	0.0962	
11/30/2017		0.128	1	12.9	0.01	0.43
12/31/2017		0.151	1	17	0.0137	0.2
1/31/2018		0.132	1	16	0.118	0.13
2/28/2018		0.213	1.5	10.4	0.0244	0.21
3/31/2018		0.287	2.28	7.09	0.114	0.09
4/30/2018	0.22	0.11	1.08	2.08	0.0799	0.32
5/31/2018	0.22	0.121	0.454	8.79	0.0138	0.30
6/30/2018	0.24	0.16	2	21.6	0.01	0.32
7/31/2018	0.22	0.147	2	27.1	0.01	0.47
8/31/2018	0.23	0.149	1.21	8.67	0.13	0.32
9/30/2018	0.25	0.156	2	23.7	0.0435	
10/31/2018	0.22	0.097	0.684	5.62	0.012	
11/30/2018		NODI: E	NODI: E	NODI: E	NODI: E	0.19
12/31/2018		0.103	0.4	5.68	0.01	0.22

Parameter	LC50 Acute Ceriodaphnia
	Daily Min
Units	%
Effluent Limit	100
Minimum	100
Maximum	100
Average	100
No. of Violations	0
7/31/2014	100
10/31/2014	100
7/31/2015	100
10/31/2015	100
7/31/2016	100
10/31/2016	100
7/31/2017	100
10/31/2017	100
7/31/2018	100
10/31/2018	100

APPENDIX A - DISCHARGE MONITORING REPORT (DMR) SUMMARY

EFFLUENT SAMPLING FROM WHOLE EFFLUENT TOXICITY (WET) TESTS

Date	Hardness CaCo3 (mg/L)	Aluminum (mg/L)	Cadmium (mg/L)	Copper (mg/L)	Lead (mg/L)	Nickel (mg/L)	Zinc (mg/L)	Alkalinity CaCo3 (mg/L)	Conductivity (umhos/cm)	Ammonia (as N) (mg/L)	pH	Tot. Org Carbon (mg/L)	Tot Diss. Solids (mg/L)	Total Solids (mg/L)
10/9/2013	168	0.14	<.001	<.005	<.005	<.005	0.033	120	740	<.3	7.4	3.4	430	440
7/21/2014	205	<.05	<.001	0.011	<.005	<.005	0.018	180	880	<.3	7.9	2.1	490	490
10/16/2014	156	<.05	<.001	0.012	<.005	<.005	0.031	99	710	<.3	7.2	3.2	500	500
7/21/2015	210	0.062	<.001	0.0062	0.0065	<.005	0.030	140	1000	<.3	7.6	2.4	660	660
10/22/2015	170	<.05	<.001	0.0097	<.005	<.005	0.040	120	750	<.3	7.2	2.7	610	610
7/13/2016	168	0.057	<.001	0.011	<.005	<.005	0.050	79	750	<.3	7.3	4.94	500	500
10/24/2016	134	0.11	<.001	0.015	<.005	<.005	0.052	36	600	<.3	7.1	5.0	340	340
7/1/2017	168							100	937		7.0			
10/18/2017	148							105	749		7.1			
7/25/2018	156							140	812		7.7			
10/24/2018	270	0.099	<.001	0.0080	<.005	<.005	0.012	230	1100	<.3	7.6	4.4	800	800

APPENDIX B

METALS REASONABLE POTENTIAL AND LIMITS CALCULATIONS

Metal	Q _d	C _d ¹		Q _s	C _s ²	Q _r	C _r		Criteria		Acute Reasonable Potential	Chronic Reasonable Potential	Limits	
	cfs	Acute (µg/l)	Chronic (µg/l)	cfs	µg/l	cfs	Acute (µg/l)	Chronic (µg/l)	Acute (µg/l)	Chronic (µg/l)	C _d & C _r > Criteria	C _d & C _r > Criteria	Acute (µg/l)	Chronic (µg/l)
Aluminum	1.84	266.0	266.0	39.94	89.0	41.78	96.80	96.8	750	87	N	Y	N/A	87.0
Cadmium		0.0	0.0		0.0		0.00	0.00	2.74	0.32	N	N	N/A	N/A
Copper		28.5	28.5		0.0		1.26	1.26	17.65	11.51	N	N	N/A	N/A
Lead		12.4	12.4		0.0		0.54	0.54	111.68	4.35	N	N	N/A	N/A
Nickel		0.0	0.0		0.0		0.00	0.00	577.74	64.23	N	N	N/A	N/A
Zinc		98.8	98.8		0.0		4.36	4.4	147.59	147.59	N	N	N/A	N/A

¹Values represent the 95th percentile (for n ≥ 10) or maximum (for n < 10) concentrations from the DMR data and/or WET testing data during the review period (see Attachments B & F). If the metal already has a limit (for either acute or chronic conditions), the value represents the existing limit.

²Median concentration for the receiving water just upstream, based on calculations.

MASSACHUSETTS DEPARTMENT OF
ENVIRONMENTAL PROTECTION
COMMONWEALTH OF MASSACHUSETTS
1 WINTER STREET
BOSTON, MASSACHUSETTS 02108

UNITED STATES ENVIRONMENTAL
PROTECTION AGENCY – REGION 1
WATER DIVISION
5 POST OFFICE SQUARE
BOSTON, MASSACHUSETTS 02109

JOINT PUBLIC NOTICE OF A DRAFT NATIONAL POLLUTANT DISCHARGE
ELIMINATION SYSTEM (NPDES) PERMIT TO DISCHARGE INTO WATERS OF THE
UNITED STATES UNDER SECTIONS 301 AND 402 OF THE CLEAN WATER ACT, AS
AMENDED, AND SECTIONS 27 AND 43 OF THE MASSACHUSETTS CLEAN WATERS
ACT, AS AMENDED, AND REQUEST FOR STATE CERTIFICATION UNDER SECTION
401 OF THE CLEAN WATER ACT.

PUBLIC NOTICE PERIOD: June 21 – July 22, 2019

PERMIT NUMBER: **MA0100935**

PUBLIC NOTICE NUMBER: MA-013-19

NAME AND MAILING ADDRESS OF APPLICANT:

Town of Lenox
Department of Public Works
275 Main Street
Lenox, MA 01240

NAME AND ADDRESS OF THE FACILITY WHERE DISCHARGE OCCURS:

Lenox Wastewater Treatment Plant
239 Crystal Street
Lenox Dale, MA 01242

RECEIVING WATER: Housatonic River (Class B)

The U.S. Environmental Protection Agency (EPA) and the Massachusetts Department of Environmental Protection (MassDEP) have cooperated in the development of a draft permit for the Lenox WWTP, which discharges treated domestic wastewater. Sludge from this facility is transported to Synagro Northeast of Waterbury, Connecticut, for incineration. The effluent limits and permit conditions imposed have been drafted to assure compliance with the Clean Water Act, 33 U.S.C. sections 1251 et seq., the Massachusetts Clean Waters Act, G.L. c. 21, §§ 26-53, 314 CMR 3.00, and State Surface Water Quality Standards at 314 CMR 4.00. EPA has requested that the State certify this draft permit pursuant to Section 401 of the Clean Water Act and expects that the draft permit will be certified.

INFORMATION ABOUT THE DRAFT PERMIT:

The draft permit and explanatory fact sheet may be obtained at no cost at http://www.epa.gov/region1/npdes/draft_permits_listing_ma.html or by contacting:

Robin Johnson
U.S. Environmental Protection Agency – Region 1
5 Post Office Square, Suite 100 (06-1)
Boston, MA 02109-3912
Telephone: (617) 918-1045
johnson.rob@epa.gov

The administrative record containing all documents relating to this draft permit including all data submitted by the applicant may be inspected at the EPA Boston office mentioned above between 9:00 a.m. and 5:00 p.m., Monday through Friday, except holidays.

PUBLIC COMMENT AND REQUEST FOR PUBLIC HEARING:

All persons, including applicants, who believe any condition of this draft permit is inappropriate, must raise all issues and submit all available arguments and all supporting material for their arguments in full by **July 22, 2019** to the address or email address listed above. Any person, prior to such date, may submit a request in writing to EPA and MassDEP for a public hearing to consider this draft permit. Such requests shall state the nature of the issues proposed to be raised in the hearing. A public hearing may be held after at least thirty days public notice whenever the Regional Administrator finds that response to this notice indicates significant public interest. In reaching a final decision on this draft permit, the Regional Administrator will respond to all significant comments and make the responses available to the public at EPA's Boston office.

FINAL PERMIT DECISION:

Following the close of the comment period, and after a public hearing, if such hearing is held, the Regional Administrator will issue a final permit decision and forward a copy of the final decision to the applicant and each person who has submitted written comments or requested notice.

LEALDON LANGLEY, DIRECTOR
WETLANDS AND WASTEWATER
PROGRAM
MASSACHUSETTS DEPARTMENT OF
ENVIRONMENTAL PROTECTION

KEN MORAFF, DIRECTOR
WATER DIVISION
EPA REGION 1