

UNITED STATES DISTRICT COURT

DISTRICT OF MINNESOTA

Civil Action Number:

UNITED STATES,
PLAINTIFF, and the

STATE OF MINNESOTA, BY THE
MINNESOTA POLLUTION CONTROL
AGENCY,
Plaintiff-Intervenor,

v.

AGRI-ENERGY, L.L.C.,
BROIN AND ASSOCIATES, INC. and
BROIN MANAGEMENT, L.L.C.
Defendants.

CONSENT DECREE

TABLE OF CONTENTS

JURISDICTION AND VENUE 4

APPLICABILITY 4

FACTUAL BACKGROUND 5

COMPLIANCE PROGRAM SUMMARY 6

COMPLIANCE PROGRAM 9

 A. Installation Of Controls.....9

 B. Permitting and Modifications..... 11

 C. Emission
 Limits.....12

 D. Demonstration of
 Compliance.....16

 E. Recordkeeping and Recording 17

CIVIL PENALTY 18

STIPULATED PENALTIES 19

RIGHT OF ENTRY 21

FORCE MAJEURE 22

DISPUTE RESOLUTION 25

GENERAL PROVISIONS..... 27

TERMINATION.....31

CONSENT DECREE

WHEREAS, Plaintiff, the United States of America (hereinafter "Plaintiff" or "the United States"), on behalf of the United States Environmental Protection Agency (herein, "EPA"), has, simultaneously with lodging of this Consent Decree, filed a Complaint alleging that Defendants, Agri-Energy LLC, Broin and Associates, Inc., and Broin Management (herein, "Agri-Energy" "Broin" or "Defendants") commenced construction of a major emitting facility and major modifications of a major emitting facility in violation of the Prevention of Significant Deterioration ("PSD") requirements at Part C of the Clean Air Act (the "Act"), 42 U.S.C. §§ 7470-7492, and the regulations promulgated thereunder at 40 C.F.R. § 52.21 (the "PSD Rules");

WHEREAS, Plaintiff further alleged that Defendants commenced construction of an emitting facility or modified an emitting facility without first obtaining the appropriate preconstruction permits and installing the appropriate air pollution control equipment required by 40 C.F.R. § 52.21 and the Minnesota State Implementation Plan ("SIP") approved pursuant to 42 U.S.C. § 7410;

WHEREAS, Plaintiff further alleged that potential air emissions from the Defendants' facility were underestimated;

WHEREAS, the State of Minnesota, through the Minnesota Pollution Control Agency ("MPCA" or "Plaintiff-Intervenor"), has, simultaneously with lodging of this Consent Decree, filed a Complaint in Intervention, alleging that Defendants were and are in violation of the Minnesota SIP, by failing to obtain the appropriate pre-construction permits, by failing to

accurately report emissions increases, and by failing to install appropriate pollution control technology, in violation of applicable state laws, including Minnesota Rule ("Minn. R.") 7007.3000;

WHEREAS, in 1996, one hundred ninety-seven (197) farm families in the Luverne area in southwestern Minnesota organized themselves into a cooperative known as Agri-Energy to build an ethanol plant;

WHEREAS, Agri-Energy applied for a minor source permit from MPCA on January 17, 1997, and began ethanol production in 1998;

WHEREAS, Agri-Energy is a small facility that has produced ethanol in the following quantities:

- 1998 -- 4.58 million gallons
- 1999 -- 15.89 million gallons
- 2000 -- 17.15 million gallons
- 2001 -- 18.74 million gallons;

WHEREAS, on October 10, 2000, Agri-Energy applied for a major amendment of its MPCA permit that included installing a scrubber on its dryer to reduce emissions;

WHEREAS, that permit was issued on December 14, 2000, and the scrubber was installed on January 20, 2001;

WHEREAS, Agri-Energy also reduced emissions by establishing a modified wet feed program;

WHEREAS, in September, 2001, Agri-Energy's Board of Directors voted to spend approximately \$1.5 to \$2 million to install a thermal oxidizer and replace the scrubber on its

dryer;

WHEREAS, on November 1, 2001, Agri-Energy ordered the thermal oxidizer;

WHEREAS, on January 22, 2002, Agri-Energy applied for an amendment to its MPCA permit in order to install its thermal oxidizer;

WHEREAS, on May 9, 2002, the MPCA issued a permit to Agri-Energy allowing it to install its thermal oxidizer;

WHEREAS, the thermal oxidizer is being installed and is expected to be operational during the fall of 2002;

WHEREAS, on February 7, 2002, the MPCA met with representatives of the ethanol plants in Minnesota, including Agri-Energy, to discuss VOC test results, VOC emissions, and related compliance issues;

WHEREAS, on April 30, 2002, Agri-Energy executed a letter of commitment to negotiate with EPA and MPCA for the installation of controls on its plant to address the possible exceedance of air quality limits;

WHEREAS, Defendants have worked cooperatively with EPA and MPCA regarding the alleged violations and voluntarily provided requested information without information requests under Section 114 of the Act, 42 U.S.C. § 7414;

WHEREAS, the Defendants do not admit the violations alleged in the Complaints;

WHEREAS, the United States and Plaintiff-Intervenor (collectively "Plaintiffs"), and the Defendants have agreed that settlement of this action is in the best interest of the parties and in the public interest, and that entry of this Consent Decree without further litigation is the most appropriate means of resolving this matter; and

WHEREAS, Plaintiffs and the Defendants consent to entry of this Consent Decree without trial of any issues;

NOW, THEREFORE, without any admission of fact or law, and without any admission of the violations alleged in the Complaints, it is hereby ORDERED AND DECREED as follows:

I. JURISDICTION AND VENUE

1. The Complaints state a claim upon which relief can be granted against the Defendants under Sections 113 and 167 of the Act, 42 U.S.C. §§ 7413 and 7477, and 28 U.S.C. § 1355. This Court has jurisdiction of the subject matter herein and over the parties consenting hereto pursuant to 28 U.S.C. § 1345 and pursuant to Sections 113 and 167 of the Act, 42 U.S.C. §§ 7413 and 7477. Venue is proper under Section 113(b) of the Act, 42 U.S.C. § 7413(b), and under 28 U.S.C. § 1391(b) and (c).

II. APPLICABILITY

2. The provisions of this Consent Decree shall apply to and be binding upon the Plaintiffs and upon the Defendants as well as the Defendants' officers, employees, agents, successors and assigns. In the event Defendants propose to sell or transfer their facility (i.e., a plant or mill) subject to this Consent Decree before termination of the Consent Decree, it shall advise such proposed purchaser or successor-in-interest in writing of the existence of this Consent Decree, and shall send a copy of such written notification by certified mail, return receipt requested, to the EPA Regional Administrator for the region in which the facility is located before such sale or transfer, if possible, but no later than the closing date of such sale or transfer. The Defendants shall provide a copy of the Consent Decree and the Control Technology Plan required in Paragraph 15 of this Consent Decree to the proposed purchaser or

successor-in-interest. In the event the Defendants sell or otherwise assign any of their right, title, or interest in their facility, prior to termination of the Consent Decree, the conveyance shall not release the Defendants from any obligation imposed by this Consent Decree unless the party to whom the right, title or interest has been transferred agrees in writing to fulfill the obligations of this Consent Decree.

III. FACTUAL BACKGROUND AND APPLICABLE DEFINITIONS

3. (a) Agri-Energy and Broin are “persons” as defined in Section 302(e) of the Act, 42 U.S.C. § 7602(e), and the federal and state regulations promulgated pursuant to the Act, and Broin is an “operator” as defined in Section 113(h) of the Act, 42 U.S.C. § 7613(h), and the federal and state regulations promulgated pursuant to the Act.

(b) Agri-Energy owns and Broin operates, a plant in Luverne, Minnesota, for the manufacture of ethanol. Agri-Energy receives whole corn which is then milled, cooked, and fermented. After fermentation, the raw product is distilled to produce ethanol. Distillation separates the liquid ethanol from the corn meal, which Agri-Energy may dry or sell as wet mash for animal feed. The Plaintiffs allege that in the course of these manufacturing activities significant quantities of particulate matter (“PM”), particulate matter at or below 10 microns (“PM₁₀”), carbon monoxide (“CO”), volatile organic compounds (“VOCs”), nitrogen oxides (“NOx”) and other pollutants are generated, including hazardous air pollutants (“HAPs”) listed under Section 112(b)(1), 42 U.S.C. § 7412(b)(1) of the Act. The primary sources of these emissions are the feed dryers, fermentation units, gas boilers, cooling cyclones, ethanol truck load-out systems, and the fugitive dust emissions from the facility operations, including roads.

(c) Plaintiffs allege that Defendants’ ethanol plant in Luverne, Minnesota is a

“major emitting facility,” as defined by Section 169(1) of the Act, 42 U.S.C. § 7479(1), and the federal and state regulations promulgated pursuant to the Act.

(d) Definitions: Unless otherwise defined herein, terms used in this Consent Decree shall have the meaning given to those terms in the Act, and the federal and state regulations promulgated pursuant to the Act.

IV. COMPLIANCE PROGRAM SUMMARY

4. Defendants shall implement a program of compliance at their ethanol distillation facility to attain the emission levels required under this Consent Decree for VOC, PM, PM₁₀, CO, and NO_x. Defendants' compliance program is summarized below in Paragraphs 5 through 10, and implemented through Paragraphs 15 through 17 and 26 through 28 of this Consent Decree.

5. Defendants shall implement a program to control and minimize fugitive particulate matter emissions from facility operations as set forth in the approved Control Technology Plan required under Part V of this Consent Decree and which is Attachment 1 to this Consent Decree.

6. Defendants shall demonstrate compliance with the required emission levels on a unit-by-unit basis as set forth in the approved Control Technology Plan.

7. Defendants shall demonstrate compliance with the emission limits established under this Consent Decree by the use of performance testing, parametric monitoring, recordkeeping and reporting, or initial and periodic compliance testing, where appropriate, as set forth in the approved Control Technology Plan.

8. Defendants shall maintain records to demonstrate compliance with New Source

Performance Standards (“NSPS”), Part 60, Subparts Dc, Kb, and VV, and their fugitive dust management program.

9. Defendants shall accept source-wide allowable emission caps equivalent to 95 tons per year (“TPY”), for each pollutant, for VOCs, PM, PM₁₀, sulfur dioxide (“SO₂”), NO_x, and CO based on a 12-month rolling sum, rolled monthly, and recorded monthly.

10. Defendants shall apply for a modification to their federally-enforceable operating permit to incorporate the 95 TPY allowable emission caps and the lower emission limits applicable to each unit as set forth in the approved Control Technology Plan.

11. Defendants shall obtain a federally-enforceable permit prior to beginning construction or operation of any future modification that will result in a significant net emission increase as defined by 40 C.F.R. Part 52, but will not exceed the 95 TPY allowable emission caps. The modifications required in Part V Section A (“Installation of Controls and Applicable Emission Limits”) of this Consent Decree and any modification that qualifies under Minnesota Rule 7007.1250 and 7007.1450 subp. 2 are excluded from the requirements of this Paragraph. For purposes of determining whether a modification will result in a significant net emissions increase, Defendants shall use results from their initial compliance testing to determine their past actual emissions baseline. Defendants shall include in their application for the federally-enforceable permit, and MPCA shall propose to incorporate in the permit, the 95 TPY allowable emission caps or a schedule to meet the 95 TPY allowable emission caps and all emission limits, monitoring and recordkeeping requirements as set forth in the approved Control Technology Plan and this Consent Decree, and Defendants shall not contest what is contained in their permit application.

12. If, as a result of any future modifications, prior to termination of the Consent Decree, the total limited potential emissions of VOCs, PM, PM₁₀, SO₂, NO_x and CO will exceed the 95 TPY allowable emission caps, then Defendants shall complete and submit for MPCA approval a source-wide PSD/NSR permit application that includes the approved Control Technology Plan requirements as set forth in this Consent Decree. To the extent that Defendants demonstrate, through results of compliance tests or evidence of operating conditions, that their facility has operated below the 95 TPY emission caps for 24 months, the facility shall be treated as a synthetic minor for air permitting requirements and permit requirements for future modifications will be governed by applicable state and federal regulations.

13. Except as provided in Paragraph 12, if as a result of any future modifications, prior to termination of the Consent Decree, the total limited potential emissions of VOCs, PM, PM₁₀, SO₂, NO_x and CO will exceed the 95 TPY allowable emission caps, then Defendants shall obtain a PSD/NSR permit prior to beginning construction of those modifications. Following termination of the Consent Decree, Defendants shall obtain necessary permits or permit amendments, as required under applicable state and federal regulations.

14. Defendants shall include in their application, and MPCA shall propose to incorporate, the emission limits, monitoring and recordkeeping requirements of the approved Control Technology Plan and this Consent Decree into any existing or new permit issued to the source as federally-enforceable Title I permit conditions and such emission limits, monitoring and recordkeeping requirements shall remain applicable to the source for the life of its operation or until changed through a permit amendment. Defendants shall not contest what is contained in their permit application. Requirements under this Consent Decree excluded under this Paragraph

as Title I conditions are NSPS Subparts Dc, Kb, and VV, and the fugitive emission control program referenced in Paragraphs 15(j) and (h), respectively. In addition, the Consent Decree shall be referenced in the permit as the legal basis for all applicable requirements created by the Consent Decree.

V. COMPLIANCE PROGRAM REQUIREMENTS

A. Installation Of Controls And Applicable Emission Limits

15. Defendants shall implement a plan for the installation of air pollution control technology ("Control Technology Plan") capable of meeting the following emission level reductions for the identified units in subparagraphs (a) through (j). Defendants' Control Technology Plan, which has been approved by Plaintiffs, is Attachment 1 to this Consent Decree:

(a) Feed Dryers: 95 percent reduction of VOC or emissions no higher than 10 parts per million ("PPM") of VOC, 90 percent reduction of CO emissions or emissions no higher than 100 PPM CO, and reduction of PM and PM₁₀ based on operation of pollution control technology specified in the approved Control Technology Plan and as established after initial performance testing pursuant to Paragraph 24 of this Consent Decree. A NO_x emission factor shall be established after initial performance testing required pursuant to Paragraph 23 of this Consent Decree. The emission factor will be used to determine compliance with Paragraph 15(g). The following unit is subject to these limits: EU 015

(b) Fermentation Units: 95 percent reduction of VOC or 10 PPM of VOC. The following units are subject to this limit: EU 025 – 028

(c) Gas Boilers: A NO_x emission factor shall be established after initial performance testing required pursuant to Paragraph 23 of this Consent Decree. The emission factor will be used to determine compliance with Paragraph 15(g). The following unit is subject to these limits: EU 018

(d) Cooling Cyclones: VOC emission limit(s) shall be established after initial performance testing pursuant to Paragraph 22 of

this Consent Decree. The following unit is subject to this limit: EU 024

(e) Fugitive Dust Control PM: A program shall be developed for minimization of fugitive dust emissions from facility operations. The following area is subject to this program: FS 001

(f) Ethanol Loadout:
Truck loadout: Design an enclosure for total capture of VOC and operate a closed loop system vented to the feed dryer control equipment for destruction of the captured VOC.
Railcar loadout: All railcars shall be dedicated as ethanol only.
The following unit is subject to this limit: FS 003

(g) Additional Requirements for NO_x Emission Units:
Establish a Group NO_x limit based on 0.04 lbs of NO_x per unit, per MMBtu at capacity. An adjustment for propane usage may be made for a designated period of time based on a limit of 0.08 lbs of NO_x per MMBtu. Emission factors for each unit in this group shall be established during the initial performance test required in Paragraph 23 of this Consent Decree and will be used to calculate compliance with the Group NO_x limit, based on actual fuel usage for all emission units in this group. The fuel used by this group as a whole shall not allow NO_x emissions in excess of 35.5 TPY. The following units are subject to this limit: EU 015, EU 018, EU 032

(h) Fugitive VOC: Implement and comply with the requirements of 40 C.F.R. Part 60, Subpart VV. The following unit is subject to these requirements: FS 005

(i) Additional Requirements for Hazardous Air Pollutants ("HAPs"): Beginning no later than 180 days following the start-up of the last piece of control equipment required in the approved Control Technology Plan. Defendants shall continually operate their facility so as not to exceed source-wide allowable emissions of 9.0 TPY for any single HAP or 24.0 TPY for all HAPs based on a 12-month rolling sum, rolled monthly, and recorded monthly. For the first eleven months, beginning no later than 180 days following start-up of the last piece of control equipment required in the approved Control Technology Plan, compliance with the 12-month rolling sum will be demonstrated based on the schedule to meet applicable emission caps as set forth in the approved Control Technology Plan. If, based on emissions testing as set forth in the approved Control Technology Plan, additional control measures are required to meet the 9.0 or 24.0 TPY emission caps, such control measures shall be implemented and included in the operating permit application required under Paragraph

17.

(j) **New Source Performance Standards (NSPS):** Identify and implement applicable NSPS requirements codified at 40 C.F.R. Part 60. The following NSPS apply: NSPS subpart Dc (Small Industrial Commercial-Institutional Steam Generating Units less than 29 MW (100 million BTu/hour)); NSPS subpart Kb (Volatile Organic Liquid Storage Vessels); and NSPS subpart VV (Synthetic Organic Chemicals Manufacturing Industry Leak Detection, Monitoring and Repair Requirements).

16. Defendants shall implement the approved Control Technology Plan in accordance with the schedule set forth in that plan. Defendants' approved Control Technology Plan is incorporated by reference herein and made directly enforceable by Plaintiffs under this Consent Decree.

B. Permitting And Modifications

17. Source-wide Permit: By no later than 180 days following the start-up of the last piece of control equipment required in the approved Control Technology Plan, Defendants shall apply for a modification to their federally-enforceable operating permit(s) to incorporate the 95 TPY source-wide allowable emission caps as described in Paragraph 9.

18. Future Modifications: Except as provided in Paragraph 12, for the effective period of the Consent Decree, Defendants shall obtain a federally-enforceable permit prior to beginning construction or operation of any future modification that will result in a significant net emission increase as defined by 40 C.F.R. Part 52, but will not exceed the 95 TPY allowable emission caps. The modifications required in Part V Section A ("Installation of Controls and Applicable Emission Limits") and the approved Control Technology Plan of this Consent Decree and any modification that qualifies under Minnesota Rule 7007.1250 and 7007.1450 subp. 2 are excluded from the requirements of this Paragraph. This permit shall incorporate the 95 TPY allowable

emission caps or a schedule to meet the 95 TPY allowable emission caps and emission limits, monitoring and recordkeeping requirements as set forth in the approved Control Technology Plan and this Consent Decree, including the requirements establishing the emission level reductions within the Control Technology Plan.

19. In determining whether a future modification will result in a significant net emissions increase, Defendants cannot take credit for any emission reductions resulting from the implementation of the approved Control Technology Plan for netting purposes as defined by 40 C.F.R. § 52.21(b)(3). In addition, the emission reductions of PM, PM₁₀, NO_x, SO₂ and CO required under this Consent Decree and the applicable NSPS may not be used for any emissions offset, banking, selling or trading program. VOC emissions reductions up to 98 percent of the uncontrolled feed dryer emissions may not be used for any emissions offset, banking, selling or trading program.

20. Except as provided in Paragraph 12, Defendants shall obtain a PSD permit prior to beginning construction of any future modifications during the effective period of the Consent Decree that will cause any increase in their limited potential emissions of any pollutant regulated under the Act above the 95 TPY source-wide caps, or prior to relaxation of a federally-enforceable permit limit pursuant to 40 C.F.R. § 52.21(r)(4).

C. Emission Limits

21. Unit Emission Limit for VOC, CO, NO_x:

Beginning no later than 180 days following the start-up of each piece of control equipment required in their approved Control Technology Plan, Defendants shall continually operate each unit in accordance with the operating parameters set forth in the approved Control

Technology Plan.

22. VOC Limit for Cooling Cyclone:

(a) By no later than 90 days following the initial performance test of the cooling cyclone as required in Paragraphs 15(d) and 28, Defendants shall submit a written evaluation of the technical feasibility and cost effectiveness of additional VOC control equipment for the cooling cyclone and the technical feasibility and cost effectiveness of either directly or indirectly routing the cooling cyclone emissions to feed dryer control equipment.

(1) If the evaluation demonstrates that additional controls or routing the emissions to the feed dryer control equipment are technically feasible and cost effective, a schedule to install the controls and interim VOC emission limit(s) to apply until controls are installed must be included in the evaluation.

(2) If Defendants conclude that additional controls are not technically feasible and cost effective, Defendants shall propose a VOC emission limit(s) based on the data collected from initial performance testing and other available pertinent information.

(b) Defendants shall immediately comply with the proposed VOC emission limit(s) or interim VOC emission limit(s).

(c) MPCA will use the data collected, the control equipment evaluation and other available pertinent information to establish a VOC emission limit(s) for the cooling cyclone and, if necessary, the required emissions control or to support a determination that additional controls are not technically feasible or cost-effective. MPCA shall provide written notice to Defendants of the established limit, or the additional required controls, and MPCA's notice shall be incorporated into and enforceable under this Consent Decree.

(1) If the limit established by the MPCA is more stringent than the limit proposed by Defendants, Defendants shall have 30 days from the date of the written notice to comply with the established limit(s).

(2) If MPCA determines that controls are required in addition to, or different from, those proposed by Defendants, Defendants shall have 30 days from the date of the written notice to provide MPCA with a schedule to install the controls. The MPCA shall allow Defendants a reasonable time to install the required controls. If Defendants contest the MPCA's proposed limit or MPCA's proposed controls, Defendants shall have 60 days to invoke the Dispute Resolution process pursuant to Part X ("Dispute Resolution") and obtain a stay from the Court. Until a limit is established under the Dispute Resolution process herein, Defendants shall comply with the emission limit(s) it proposed under Paragraph 22(a)(2).

23. NO_x Emission Factors: Following the initial performance test as required in Paragraphs 15 (a), (c), and (g) and 28, Defendants shall establish unit specific NO_x emission factors that it will use to calculate actual NO_x emissions to demonstrate compliance with Paragraph 15(g). The method to determine compliance with the limit in Paragraph 15(g) is specified in the approved Control Technology Plan.

24. Unit Emission Limit for PM and PM₁₀: By no later than 45 days following the initial performance test of the control equipment for the feed dryer as required in Paragraphs 15(a) and 28, Defendants shall propose PM and PM₁₀ emission limits based on the data collected from initial performance testing and other available pertinent information. Defendants shall immediately comply with the proposed emission limit. MPCA will use the data collected and other available pertinent information to establish limits for PM and PM₁₀. MPCA shall provide

written notice to Defendants of the established limit and the established limit shall be incorporated into and enforceable under this Consent Decree. If Defendants contest the MPCA's proposed limit, Defendants shall have 60 days to invoke the Dispute Resolution process pursuant to Part X ("Dispute Resolution") and obtain a stay from the Court. Until a limit is established under the Dispute Resolution process herein, Defendants shall comply with the emission limit(s) it proposed under this Paragraph.

25. Unit Operating Permits: By no later than 180 days following start-up of the last piece of control equipment required in their approved Control Technology Plan, Defendants shall apply for modification to their federally-enforceable operating permit to incorporate the emission limits, monitoring parameters, and recordkeeping set forth in the approved Control Technology Plan and this Consent Decree.

26. Source-wide Caps:

(a) Beginning no later than 180 days following start-up of the last piece of control equipment required in their approved Control Technology Plan, Defendants shall continually operate their facility so as not to exceed the source-wide allowable emission caps of 95 TPY for each pollutant for VOCs, PM, PM₁₀, SO₂, NO_x, and CO based on a 12-month rolling sum, rolled monthly, and recorded monthly. For the first eleven months, beginning no later than 180 days following start-up of the last piece of control equipment required in the approved Control Technology Plan, compliance with the 12-month rolling sum will be demonstrated based on a schedule to meet applicable emission caps as set forth in the approved Control Technology Plan. This provision shall survive termination of this Consent Decree until the 95 TPY emission caps are amended by or incorporated into a federally-enforceable permit for the facility.

(b) Beginning no later than 180 days following start-up of the last piece of control equipment required in their approved Control Technology Plan, Defendants shall continually operate their facility so as not to exceed the source-wide allowable emission caps of 9.0 TPY for any single hazardous air pollutant or 24.0 TPY for all hazardous air pollutants based on a 12-month rolling sum, rolled monthly, and recorded monthly. For the first eleven months, beginning no later than 180 days following start-up of the last piece of control equipment required in the approved Control Technology Plan, compliance with the 12-month rolling sum will be demonstrated based on a schedule to meet applicable emission caps as set forth in the approved Control Technology Plan. This provision shall survive termination of this Consent Decree until the 9.0 TPY and 24.0 TPY emission caps are amended by or incorporated into a federally-enforceable permit for the facility.

D. Demonstration Of Compliance

27. Defendants shall demonstrate continuous compliance with the emission limits established under this Consent Decree by the use of parametric monitoring, recordkeeping and reporting, as set forth in the approved Control Technology Plan.

28. By no later than 120 days following the start-up of the last piece of control equipment required in the approved Control Technology Plan, Defendants shall demonstrate through emissions testing of each emissions unit as specified in the approved Control Technology Plan, conducted in accordance with a MPCA and U.S. EPA approved test protocol, that it has met the required destruction efficiency and/or emission limit. Defendants shall follow all testing requirements in Minnesota Rule 7017. Defendants shall retest the dryer for VOCs, CO, PM, and PM₁₀ no less than annually for the effective period of the Consent Decree.

Defendants shall retest all other units in accordance with MPCA's policy regarding performance testing frequency.

29. Defendants shall maintain control technology performance criteria monitoring data and records as set forth in the approved Control Technology Plan, and shall make them available to the Plaintiffs upon demand as soon as practicable.

E. Recordkeeping And Reporting Requirements

30. Beginning with the first full calendar quarter following lodging of this Consent Decree, Defendants shall submit written reports within 30 days following each calendar quarter to MPCA and U.S. EPA that itemize Consent Decree requirements and the approved Control Technology Plan requirements, the applicable deadlines, the dates the tasks were completed, unit emissions data and data to support Defendants' compliance status with the terms of this Consent Decree. Reports shall be sent to the addresses identified in Paragraph 64 ("Notice"). Emissions data may be submitted in electronic format.

31. Defendants shall preserve and retain all records and documents now in their possession or control, or which come into their possession or control, that support the reporting and compliance requirements under this Part for a period of three years following the termination of this Consent Decree, unless other regulations require the records to be maintained longer.

32. All notices, reports or any other submissions from Defendants shall contain the following certification and may be signed by an owner or operator of the company responsible for environmental management and compliance:

"I certify under penalty of law that I have personally examined the information submitted herein and that I have made a diligent inquiry of those individuals immediately responsible for obtaining the information and that to the best of my knowledge and belief,

the information submitted herewith is true, accurate, and complete. I am aware that there are significant penalties for submitting false information, including the possibility of fine and imprisonment.”

VI. CIVIL PENALTY

33. Within thirty (30) calendar days of entry of this Consent Decree, the Defendants shall pay to the Plaintiffs a civil penalty pursuant to Section 113 of the Act, 42 U.S.C. § 7413 and Minn. Stat. § 115.071, in the amount of \$31,598 (Thirty-One Thousand Five Hundred and Ninety-Eight Dollars). Pursuant to the Act, the following factors were considered in determining a civil penalty, in addition to other factors as justice may require, the size of the business, the economic impact of the penalty on the business, the violator's full compliance history and good faith efforts to comply, the duration of the violation, payment by the violator of penalties previously assessed for the same violation, the economic benefit of noncompliance, and the seriousness of the violation.

34. Of the total penalty, \$15,799, shall be paid to the United States by Electronic Funds Transfer ("EFT") to the United States Department of Justice, in accordance with current EFT procedures, referencing the USAO File Number and DOJ Case Number 90-5-2-1-07784, and the civil action case name and case number of the District of Minnesota. The costs of such EFT shall be Defendants' responsibility. Payment shall be made in accordance with instructions provided to Defendants by the Financial Litigation Unit of the U.S. Attorney's Office in the District of Minnesota. Any funds received after 11:00 a.m. (EST) shall be credited on the next business day. Defendants shall provide notice of payment, referencing the USAO File Number and DOJ Case Number 90-5-2-1-07784, and the civil action case name and case number, to the Department of Justice and to EPA, as provided in Paragraph 64 ("Notice"). The total remaining

amount, \$15,799 in civil penalties, shall be paid to the Plaintiff-Intervenor the State of Minnesota, made in the form of a certified check payable to the Minnesota Pollution Control Agency and delivered to:

Enforcement Penalty Coordinator
Minnesota Pollution Control Agency
520 Lafayette Road
St. Paul, Minnesota 55155-4194

35. The Defendants shall pay statutory interest on any over due civil penalty or stipulated penalty amount at the rate specified in 31 U.S.C. § 3717. Upon entry of this Consent Decree, this Consent Decree shall constitute an enforceable judgment for purposes of post-judgment collection in accordance with Rule 69 of the Federal Rules of Civil Procedure, the Federal Debt Collection Procedure Act, 28 U.S.C. § 3001-3308, Minnesota Statute Chapter 16D and other applicable federal and state Authority. The Plaintiffs shall be deemed a judgment creditor for purposes of collection of any unpaid amounts of the civil and stipulated penalties and interest.

36. No amount of the \$31,598 civil penalty to be paid by Defendants shall be used to reduce their federal or state tax obligations.

VII. STIPULATED PENALTIES

37. The Defendants shall pay stipulated penalties in the amounts set forth below to the Plaintiffs, to be paid 50 percent to the United States and 50 percent to the Plaintiff-Intervenor, for the following:

(a) for each day of failure to propose PM, PM₁₀, and VOC emissions limits under Paragraphs 22 and 24:

1st through 30th day after deadline	\$ 250
-------------------------------------	--------

31st through 60th day after deadline \$ 500

Beyond the 60th day \$1000

(b) for each day of failure to meet the deadlines for installation of control technology systems set forth in the Control Technology Plan and applying for, or obtaining, permits under Paragraphs 17, 18, 20, and 25:

1st through 30th day after deadline \$ 800

31st through 60th day after deadline \$1,200

Beyond 60th day \$2,000

(c) for failure to conduct a compliance test as required by Paragraph 28, per day per unit:

1st through 30th day after deadline \$ 250

31st through 60th day after deadline \$ 500

Beyond 60th day \$1,000

(d) for failure to demonstrate compliance with emission limits set forth in the approved Control Technology Plan or emission limits set pursuant to Part V Section C ("Emission Limits"): \$5000 per emissions test for each pollutant

(e) for each failure to submit reports or studies as required by Part V Section E ("Recordkeeping and Reporting Requirements") of this Consent Decree, per day per report or notice:

1st through 30th day after deadline \$ 250

31st through 60th day after deadline \$ 500

Beyond 60th day \$1,000

(f) for failure to pay or escrow stipulated penalties, as specified in Paragraphs 38 and 39 of this section, \$500 per day per penalty demand.

(g) for failure to notify the Plaintiffs pursuant to Paragraph 2 of Defendants' sale or transfer of the facility, \$250 per day.

38. Defendants shall pay stipulated penalties upon written demand by the Plaintiffs no later than thirty (30) days after Defendants receive such demand. Stipulated penalties shall be paid to the Plaintiffs in the manner set forth in Part VI ("Civil Penalty") of this Consent Decree.

39. Should Defendants dispute their obligation to pay part or all of a stipulated penalty, they may avoid the imposition of the stipulated penalty for failure to pay a penalty due to the Plaintiffs by placing the disputed amount demanded by the Plaintiffs, not to exceed \$20,000 for any given event or related series of events at any one plant, in a commercial escrow account pending resolution of the matter and by invoking the Dispute Resolution provisions of Part X within the time provided in Paragraph 38 for payment of stipulated penalties. If the dispute is thereafter resolved in Defendants' favor, the escrowed amount plus accrued interest shall be returned to the Defendants. Otherwise the Plaintiffs shall be entitled to the escrowed amount that was determined to be due by the Court plus the interest that has accrued on such amount, with the balance, if any, returned to the Defendants.

40. The Plaintiffs reserve the right to pursue any other remedies for violations of this Consent Decree to which they are entitled. The Plaintiffs will not seek stipulated penalties and civil or administrative penalties for the same violation of the Consent Decree.

VIII. RIGHT OF ENTRY

41. Any authorized representative of the EPA or MPCA, or an appropriate federal or

state agency, including independent contractors, upon presentation of proper credentials and in compliance with the facility's safety requirements, shall have a right of entry upon the premises of Defendants' plant identified herein at Paragraph 3(b) at any reasonable time for the purpose of monitoring compliance with the provisions of this Consent Decree, including inspecting plant equipment, and inspecting and copying all records maintained by Defendants required by this Consent Decree. Nothing in this Consent Decree shall limit the authority of EPA and MPCA to conduct tests and inspections under Section 114 of the Act, 42 U.S.C. § 7414, and Minnesota Statute §§ 116.07, subd. 9 and 116.091 or any other applicable law.

IX. FORCE MAJEURE

42. If any event occurs which causes or may cause a delay or impediment to performance in complying with any provision of this Consent Decree, Defendants shall notify the Plaintiffs in writing as soon as practicable, but in any event within twenty (20) business days of when Defendants first knew of the event or should have known of the event by the exercise of due diligence. In this notice Defendants shall specifically reference this Paragraph of this Consent Decree and describe the anticipated length of time the delay may persist, the cause or causes of the delay, and the measures taken or to be taken by Defendants to prevent or minimize the delay and the schedule by which those measures will be implemented. Defendants shall adopt all reasonable measures to avoid or minimize such delays.

43. Failure by Defendants to provide notice to Plaintiffs of an event which causes or may cause a delay or impediment to performance shall render this Part IX voidable by the Plaintiffs as to the specific event for which the Defendants have failed to comply with such notice requirement, and, if voided, is of no effect as to the particular event involved.

44. The United States or MPCA shall notify the Defendants in writing regarding the Defendants' claim of a delay or impediment to performance as soon as practicable, but in any event within thirty (30) days of receipt of the Force Majeure notice provided under Paragraph 42. If the Plaintiffs agree that the delay or impediment to performance has been or will be caused by circumstances beyond the control of the Defendants, including any entity controlled by the Defendants, and that the Defendants could not have prevented the delay by the exercise of due diligence, the parties shall stipulate to an extension of the required deadline(s) for all requirement(s) affected by the delay by a period equivalent to the delay actually caused by such circumstances. The Defendants shall not be liable for stipulated penalties for the period of any such delay.

45. If the Plaintiffs do not accept the Defendants' claim that a delay or impediment to performance is caused by a force majeure event, to avoid payment of stipulated penalties, the Defendants must submit the matter to this Court for resolution within twenty (20) business days after receiving notice of the Plaintiffs' position, by filing a petition for determination with this Court. Once the Defendants have submitted this matter to this Court, the Plaintiffs shall have twenty (20) business days to file their response to said petition. If the Defendants submit the matter to this Court for resolution and the Court determines that the delay or impediment to performance has been or will be caused by circumstances beyond the control of the Defendants, including any entity controlled by the Defendants, and that the Defendants could not have prevented the delay by the exercise of due diligence, the Defendants shall be excused as to that event(s) and delay (including stipulated penalties), for a period of time equivalent to the delay caused by such circumstances.

46. The Defendants shall bear the burden of proving that any delay of any requirement(s) of this Consent Decree was caused by or will be caused by circumstances beyond their control, including any entity controlled by it, and that the Defendants could not have prevented the delay by the exercise of due diligence. The Defendants shall also bear the burden of proving the duration and extent of any delay(s) attributable to such circumstances. An extension of one compliance date based on a particular event may, but does not necessarily, result in an extension of a subsequent compliance date or dates.

47. Unanticipated or increased costs or expenses associated with the performance of the Defendants' obligations under this Consent Decree shall not constitute circumstances beyond the control of the Defendants, or serve as a basis for an extension of time under this Part. However, failure of a permitting authority to issue a necessary permit in a timely fashion is an event of Force Majeure where the Defendants have taken all steps available to it to obtain the necessary permit including but not limited to:

- (a) submitting a timely and complete permit application;
- (b) responding to requests for additional information by the permitting authority in a timely fashion; and
- (c) prosecuting appeals of any disputed terms and conditions imposed by the permitting authority in an expeditious fashion.

48. Notwithstanding any other provision of this Consent Decree, this Court shall not draw any inferences nor establish any presumptions adverse to either party as a result of Defendants delivering a notice of Force Majeure or the parties' inability to reach agreement.

49. As part of the resolution of any matter submitted to this Court under this Part IX.

the parties by agreement, or this Court, by order, may in appropriate circumstances extend or modify the schedule for completion of work under this Consent Decree to account for the delay in the work that occurred as a result of any delay or impediment to performance agreed to by the Plaintiffs or approved by this Court. Defendants shall be liable for stipulated penalties for their failure thereafter to complete the work in accordance with the extended or modified schedule.

X. DISPUTE RESOLUTION

50. The dispute resolution procedure provided by this Part X shall be available to resolve all disputes arising under this Consent Decree, including but not limited to emission limits established by the MPCA in Part V Section C ("Emission Limits"), except as otherwise provided in Part IX regarding Force Majeure.

51. The dispute resolution procedure required herein shall be invoked upon the giving of written notice by one of the parties to this Consent Decree to another advising of a dispute pursuant to this Part X. The notice shall describe the nature of the dispute, and shall state the noticing party's position with regard to such dispute. The party receiving such a notice shall acknowledge receipt of the notice and the parties shall expeditiously schedule a meeting to discuss the dispute informally not later than fourteen (14) days from the receipt of such notice.

52. Disputes submitted to dispute resolution shall, in the first instance, be the subject of informal negotiations between the parties. Such period of informal negotiations shall not extend beyond thirty (30) calendar days from the date of the first meeting between representatives of the Plaintiffs and the Defendants, unless the parties' representatives agree to shorten or extend this period.

53. In the event that the parties are unable to reach agreement during such informal

negotiation period, the Plaintiffs shall provide the Defendants with a written summary of their position regarding the dispute. The position advanced by the Plaintiffs shall be considered binding unless, within forty-five (45) calendar days of the Defendants' receipt of the written summary of the Plaintiffs position, the Defendants file with this Court a petition which describes the nature of the dispute, and includes a statement of the Defendants' position and any supporting data, analysis, and/or documentation relied on by the Defendants. The Plaintiffs shall respond to the petition within forty-five (45) calendar days of filing.

54. Where the nature of the dispute is such that a more timely resolution of the issue is required, the time periods set out in this Part X may be shortened upon motion of one of the parties to the dispute.

55. Notwithstanding any other provision of this Consent Decree, in dispute resolution, this Court shall not draw any inferences nor establish any presumptions adverse to either party as a result of invocation of this Part X or the parties' inability to reach agreement. The final position of the Plaintiffs shall be upheld by the Court if supported by substantial evidence in the record as identified and agreed to by all the Parties.

56. As part of the resolution of any dispute submitted to dispute resolution, the parties, by agreement, or this Court, by order, may, in appropriate circumstances, extend or modify the schedule for completion of work under this Consent Decree to account for the delay in the work that occurred as a result of dispute resolution. Defendants shall be liable for stipulated penalties for their failure thereafter to complete the work in accordance with the extended or modified schedule.

XI. GENERAL PROVISIONS

57. Effect of Settlement. This Consent Decree is not a permit; compliance with its terms does not guarantee compliance with any applicable federal, state or local laws or regulations. To the extent that the terms of this Consent Decree conflict with the terms of any air quality permit, the terms of this Consent Decree shall control during the effective period of the Consent Decree.

58. Resolution of Claims. Satisfaction of all of the requirements of this Consent Decree constitutes full settlement of and shall resolve all past civil and administrative liability of the Defendants to the Plaintiffs for the violations alleged in the United States' and Plaintiff-Intervenor's Complaints and all civil and administrative liability of the Defendants for any violations at their facility based on facts and events that occurred during the relevant time period under the following statutory and regulatory provisions: (a) NSPS, 40 C.F.R. Part 60, including subparts Dc, Kb, and VV; (b) National Emission Standards for Hazardous Air Pollutants, 40 C.F.R. Part 63, pursuant to Sections 112(d) and 112(g) of the Act; (c) PSD requirements at Part C of the Act and the regulations promulgated thereunder at 40 C.F.R. § 52.21, and the Minnesota regulations which incorporate and/or implement the above-listed federal regulations in items (a) through (c); (d) all air permit requirements under Minn. R. 7007.0050-7007.1850; (e) air emissions fee requirements under Minn. R. 7002.0025-7002.0095; (f) performance standards for stationary sources under Minn. R. 7011.0010-7011.9990, performance tests under Minn. R. 7017.2001-7017.2060; (g) notification, recordkeeping and reporting requirements under Minn. R. 7019.0100-7019.2000; and (h) emission inventory requirements under Minn. R. 7019.3000-7019.3100. For purposes of this Consent Decree, the "relevant time period" shall mean the

period beginning when the United States' claims and/or Plaintiff-Intervenor's claims under the above statutes and regulations accrued through the date of entry of this Consent Decree. During the effective period of the Consent Decree, certain emission units shall be on a compliance schedule and any modification to these units, as defined in 40 C.F.R. § 52.21, which is not required by this Consent Decree is beyond the scope of this resolution of claims. This provision shall survive the termination of the Consent Decree.

59. Other Laws. Except as specifically provided by this Consent Decree, nothing in this Consent Decree shall relieve Defendants of their obligation to comply with all applicable federal, state and local laws and regulations. Subject to Paragraphs 40 and 58, nothing contained in this Consent Decree shall be construed to prevent or limit the United States' or MPCA's rights to obtain penalties or injunctive relief under the Act or other federal, state or local statutes or regulations, including but not limited to, Section 303 of the Act, 42 U.S.C. § 7603.

60. Third Parties. Except as otherwise provided by law, this Consent Decree does not limit, enlarge or affect the rights of any party to this Consent Decree as against any third parties. Nothing in this Consent Decree should be construed to create any rights, or grant any cause of action, to any person not a party to this Consent Decree.

61. Costs. Each party to this Consent Decree shall bear their own costs and attorneys' fees through the date of entry of this Consent Decree.

62. Public Documents. All information and documents submitted by the Defendants to the Plaintiffs pursuant to this Consent Decree shall be subject to public inspection, unless subject to legal privileges or protection or identified and supported as business confidential by the Defendants in accordance with 40 C.F.R. Part 2 and Minnesota Statute §§ 13.37 and 116.075.

63. Public Comments - Federal Approval. The parties agree and acknowledge that final approval by the United States and entry of this Consent Decree is subject to the requirements of 28 C.F.R. § 50.7, which provides for notice of the lodging of this Consent Decree in the Federal Register, an opportunity for public comment, and consideration of any comments. The United States reserves the right to withdraw or withhold consent if the comments regarding this Consent Decree discloses facts or considerations which indicate that this Consent Decree is inappropriate, improper or inadequate. The Defendants and the Plaintiff-Intervenor consent to the entry of this Consent Decree.

64. Notice. Unless otherwise provided herein, notifications to or communications with the United States, EPA, MPCA or the Defendants shall be deemed submitted on the date they are postmarked and sent either by overnight receipt mail service or by certified or registered mail, return receipt requested. Except as otherwise provided herein, when written notification to or communication with the United States, EPA, MPCA or the Defendants is required by the terms of this Consent Decree, it shall be addressed as follows:

As to the United States:

Thomas L. Sansonetti
Assistant Attorney General
Environmental Enforcement Section
Environment and Natural Resources Division
U.S. Department of Justice
P.O. Box 7611, Ben Franklin Station
Washington, DC 20044-7611

As to the U.S. EPA:

Bruce Buckheit
Director, Air Enforcement Division
U.S. Environmental Protection Agency
Ariel Rios Building

1200 Pennsylvania Avenue, N.W.
Mail Code 2242-A
Washington, DC 20004

and the EPA Regional office for the region in which the facility is located:
Region 5:

Cynthia A. King
U.S. EPA, Region 5
C-14J
77 W. Jackson Blvd.
Chicago, IL 60604

Compliance Tracker
Air Enforcement Branch, AE-17J
U.S. EPA, Region 5
77 W. Jackson Blvd.
Chicago, IL 60604

As to Agri-Energy L.L.C.

Agri-Energy L.L.C.
Rick Serie
General Manager
502 South Walnut
Luverne, MN 56156

and

(Counsel for Defendants)

James A. Mennell
The Environmental Law Group, Ltd.
East Bridge at Riverplace
Suite 114
10 Second Street N.E.
Minneapolis, MN 55413

As to Plaintiff-Intervenor the State of Minnesota, through the MPCA:

Rhonda Land
Minnesota Pollution Control Agency
520 Lafayette Road N
St. Paul, MN 55155-4194

Kathleen L. Winters
Office of the Attorney General
NCL Towers Suite 900
445 Minnesota Street
St. Paul, MN 55101-2127

65. Change of Notice Recipient. Any party may change either the notice recipient or the address for providing notices to it by serving all other parties with a notice setting forth such new notice recipient or address.

66. Modification. There shall be no modification of this Consent Decree without written agreement of all the parties. There shall be no material modification of this Consent Decree without the written agreement of the parties and by Order of the Court. Prior to complete termination of the requirements of this Consent Decree pursuant to Paragraph 68, the parties may, upon motion to the Court, seek to terminate provisions of this Consent Decree.

67. Continuing Jurisdiction. The Court retains jurisdiction of this case after entry of this Consent Decree to enforce compliance with the terms and conditions of this Consent Decree and to take any action necessary or appropriate for its interpretation, construction, execution, or modification. During the term of this Consent Decree, any party may apply to the Court for any relief necessary to construe or effectuate this Consent Decree.

XII. TERMINATION

68. This Consent Decree shall be subject to termination upon motion by any party after the Defendants satisfy all requirements of this Consent Decree and have operated the control technologies identified in the approved Control Technology Plan in compliance with emission limits, and have demonstrated for 24 months that their actual emissions of VOCs, PM, PM₁₀, SO₂, NO_x and CO have remained under 95 TPY. For purposes of meeting the 24-month

performance requirement in this Paragraph, Defendants may demonstrate that their actual emissions remained under the 95 TPY allowable emission caps by either using the results of their initial compliance tests or evidence of operating conditions since the installation of the control equipment required in this Consent Decree and in the approved Control Technology Plan. At such time, if the Defendants believe that they are in compliance with the requirements of this Consent Decree, and have paid the civil penalty and any stipulated penalties required by this Consent Decree, then the Defendants shall so certify to the Plaintiffs, and unless the Plaintiffs object in writing with specific reasons within forty-five (45) days of receipt of the certification, the Court shall order that this Consent Decree be terminated on Defendants' motion. If the United States or MPCA objects to the Defendants' certification, then the matter shall be submitted to the Court for resolution under Part X ("Dispute Resolution") of this Consent Decree. In such case, the Defendants shall bear the burden of proving that this Consent Decree should be terminated.

So entered in accordance with the foregoing this _____ day of _____, 2002.

United States District Court Judge
District of Minnesota

FOR PLAINTIFF, UNITED STATES OF AMERICA:

Tom Sansonetti

Date 9.10.02

Thomas L. Sansonetti
Assistant Attorney General
Environment and Natural Resources Division
U.S. Department of Justice
10th & Pennsylvania Avenue, N.W.
Washington, DC 20530

Dianne M. Shawley

Date 8/23/02

Dianne M. Shawley
Senior Counsel
Environment and Natural Resources Division
U.S. Department of Justice
1425 New York Avenue, N.W.
Washington, DC 20005

Cynthia A. King

Date 8/23/02

Cynthia A. King
Special Trial Attorney
US EPA Region 5
77 W. Jackson Street
Chicago, IL 60604

United States Attorney
District of Minnesota

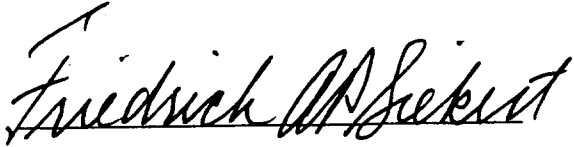

Date 10/1/02

THOMAS B. HEFFELFINGER
United States Attorney

BY: FRIEDRICH A. P. SIEKERT
Assistant U.S. Attorney
Attorney ID No. 142013
District of Minnesota
U.S. Courthouse
300 S. 4th Street
Suite 600
Minneapolis, MN 55415

FOR U.S. ENVIRONMENTAL PROTECTION AGENCY:

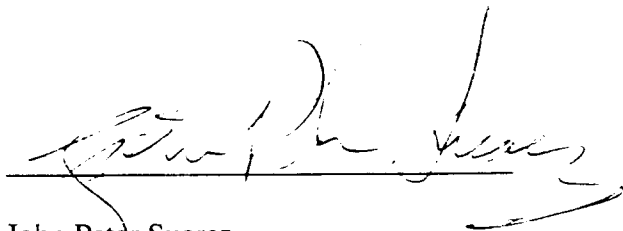
A handwritten signature in black ink, appearing to read "John Peter Suarez", written over a horizontal line.

Date 9/20/02

John Peter Suarez
Assistant Administrator
Office of Enforcement and Compliance Assurance
U.S. Environmental Protection Agency
Ariel Rios Building
1200 Pennsylvania Avenue, N.W.
Washington, DC 20460

FOR U.S. ENVIRONMENTAL PROTECTION AGENCY:

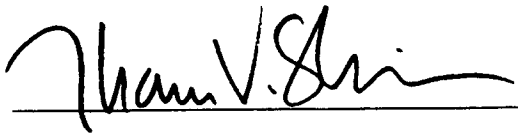

Thomas V. Skinner

Date 9.20.02

Thomas V. Skinner
Regional Administrator
U.S. Environmental Protection Agency
Region 5
77 West Jackson Street
Chicago, IL 60604

FOR THE PLAINTIFF-INTERVENOR, THE STATE OF MINNESOTA POLLUTION
CONTROL AGENCY:

Karen A. Studders
Karen A. Studders, Commissioner
Minnesota Pollution Control Agency
520 Lafayette Road
St. Paul, MN 55155

Date October 2002

FOR MIKE HATCH, ATTORNEY GENERAL

Kathleen L. Winters
Office of the Attorney General
NCL Towers Suite 900
445 Minnesota Street
St. Paul, MN 55101-2127

Date _____

FOR DEFENDANTS, AGRI-ENERGY CORPORATION, BROIN AND ASSOCIATES,
INC. AND BROIN MANAGEMENT, L.L.C.:



Date 8/9/02

Norm Smeenk, Chairman/CEO
Agri-Energy LLC
502 South Walnut
Luverne, MN 56156

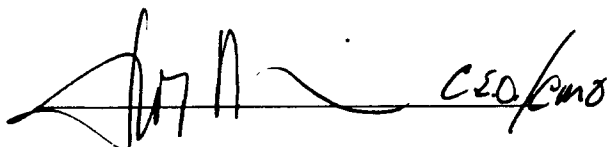

Date 8/9/02

Jeff Broin, CEO/CMO
Broin and Associates, Inc. and
Broin Management, LLC
2209 E 57th Street N
Sioux Falls, SD 57104

James A. Mennell
The Environmental Law Group, Ltd.
East Bridge at Riverplace, Suite 114
10 Second Street, N.E.
Minneapolis, MN 55413

Gerald L. Seck
Larkin, Hoffman, Daly & Lindgren, Ltd.
1500 Wells Fargo Plaza
7900 Xerxes Avenue South
Bloomington, MN 55431

Peder A. Larson
Peder Larson & Associates, PLC
5200 Willson Road
Suite 150
Minneapolis, MN 55424

Control Technology Plan For Agri-Energy

August 9, 2002

CONTENTS

1.0 INTRODUCTION	1-1
2.0 EMISSION UNITS REQUIRING POLLUTION CONTROL EQUIPMENT	2-1
3.0 ENGINEERING DESIGN CRITERIA FOR POLLUTION CONTROL EQUIPMENT	3-1
4.0 EMISSION LIMITS FROM POLLUTION CONTROL EQUIPMENT	4-1
4.1 Alternative Operating Scenario.....	4-4
5.0 POLLUTION CONTROL EQUIPMENT INSTALLATION SCHEDULE	5-5
6.0 MONITORING PARAMETERS FOR POLLUTION CONTROL DEVICES	6-1
7.0 POLLUTION CONTROL DEVICE PERFORMANCE TEST SCHEDULE AND TEST METHODS USED	7-1
8.0 FUGITIVE DUST EMISSION CONTROL PROGRAM.....	8-1

1.0 INTRODUCTION

On August 9, 2002, Agri-Energy signed a consent decree that requires Agri-Energy to implement a program of compliance at the corn dry mill ethanol plant it operates in Luverne, Minnesota. Agri-Energy prepared and submitted this Control Technology Plan (CTP) as an integral part of the consent decree. This CTP fulfills the requirements of the consent decree and has been reviewed and approved by the US Environmental Protection Agency (USEPA) and the Minnesota Pollution Control Agency (MPCA) as part of the consent decree. This CTP contains:

- (a). Identification of all units to be controlled;
- (b). Engineering design criteria for all proposed controls capable of meeting the emission levels required by Part V of this Consent Decree;
- (c). Proposed short-term and long-term emission limits and controlled outlet concentrations for each pollutant as appropriate;
- (d). A schedule for expedited installation with specific milestones applicable on a unit-by-unit basis;
- (e). Proposed monitoring parameters for all control equipment and parameter ranges;
- (f). Identification of all units to be emission tested under Paragraph 15 and 28 of this Consent Decree and a schedule for initial tests and retest;
- (g). The test methods that will be used to demonstrate compliance with the emissions levels set forth in this Consent Decree;
- (h). Program for minimization of fugitive dust emissions from facility operations.

2.0 EMISSION UNITS REQUIRING POLLUTION CONTROL EQUIPMENT

The following emission units, fugitive sources, and control equipment have been designated as affected units in the consent decree and have emission limits requiring pollution control technology.

Unit Designation #	Unit Description	CE#	Control Equipment Description
EU 015	DDGS Dryer	006	TO (VOC, HAPs, CO, PM/PM-10)
EU 018	Boiler	NA	NA
EU 024	DDGS Cooling Cyclone	NA	TBD
EU 025	Fermentation Tank #1	003/ 006	Packed bed wet scrubber (VOC) and TO (VOC, HAPs)
EU 026	Fermentation Tank #2	003/ 006	Packed bed wet scrubber (VOC) and TO (VOC, HAPs)
EU 027	Fermentation Tank #3	003/ 006	Packed bed wet scrubber (VOC) and TO (VOC, HAPs)
EU 028	Beer Well	003/ 006	Packed bed wet scrubber (VOC) and TO (VOC, HAPs)
EU 032	Thermal Oxidizer/HRSG	NA	Low NOx Burners (NOx)
FS 001	Truck Traffic	NA	Chemical Dust Suppression (PM/PM-10)
FS 003	Ethanol Truck Loadout	006	TO (VOC, HAPs)
FS 005	Valve, Flange, and Seal Fugitive Emissions	NA	LDAR program under NSPS subpart VV (VOC)

3.0 ENGINEERING DESIGN CRITERIA FOR POLLUTION CONTROL EQUIPMENT

After identifying the affected units that require installation of air pollution control technology, Agri-Energy conducted a design and engineering review of each unit to select the pollution control technology that would achieve the emission level reductions identified in the consent decree.

Process Description	Control Device #	Control Device Description	Operating Parameters
Fermentation and Beer Well	CE 003	Packed Bed Scrubber	Exhaust Flow Rate \approx 3500 scfm Water flow rate \geq 10 gpm when venting to TO and $>$ 20 gpm when vented to atmosphere
DDGS Dryer, Fermentation, Ethanol Truck Loadout	CE 006	Thermal Oxidizer for VOC, PM/PM ₁₀ and CO control Thermal oxidizer has low NO _x burners	Exhaust Flow Rate \approx 44,400 scfm Residence Time = 0.7 seconds in combustion chamber Multi- Right Angle Combustion chamber Design Fuel Input Rate = 78 MMBtu/hr
Cyclone Cooler	NA	TBD	TBD
Boiler	NA	NA	Design Fuel Input Rate = 62 MMBtu/hr

The following flow diagram presents the affected units and associated control technology as determined by the results of engineering design criteria.

AGRI-ENERGY

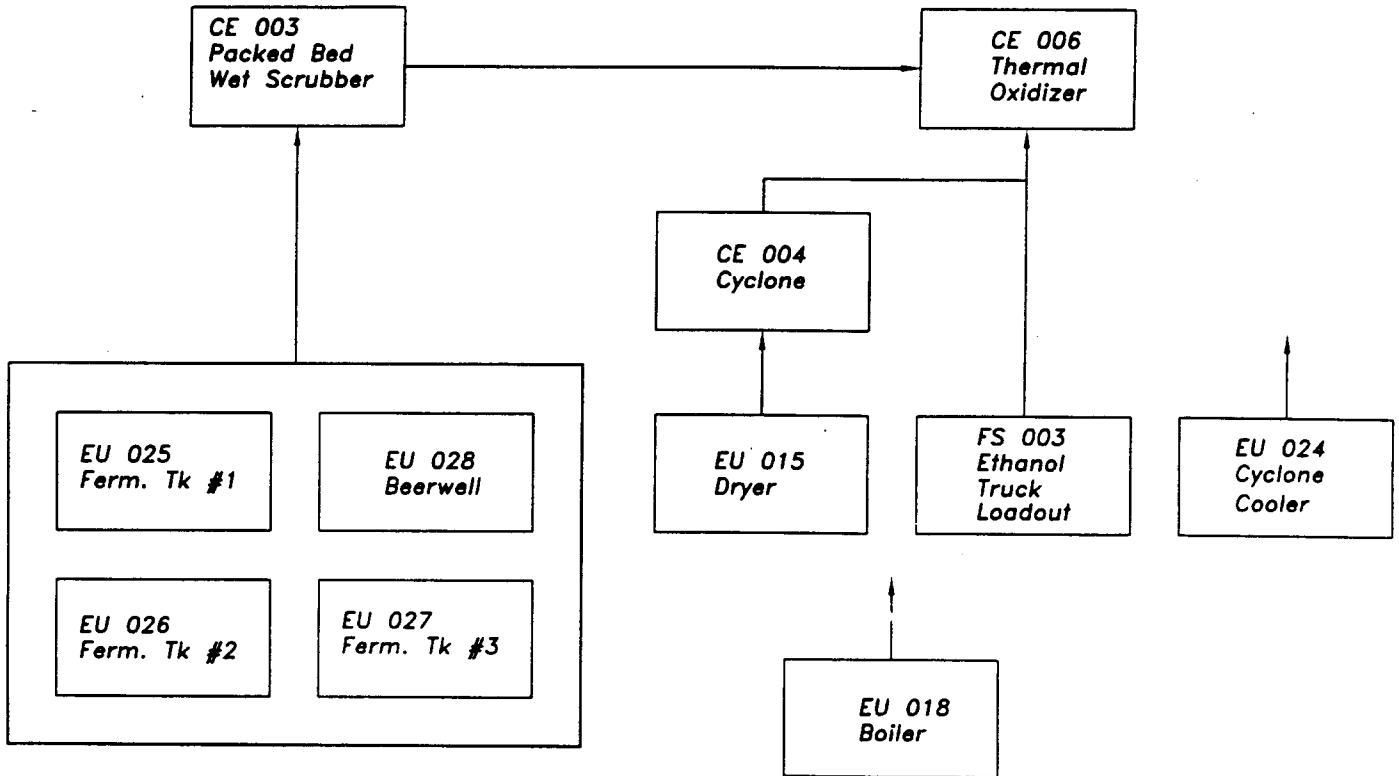

4.0 EMISSION LIMITS FROM POLLUTION CONTROL EQUIPMENT

Unless otherwise stated, all controlled emission limitations apply at all times except during periods when the process equipment is not operating or during previously planned startup and shutdown periods, and malfunctions as defined in 40 CFR section 63.2. These startup and shutdown periods shall not exceed the minimum amount of time necessary for these events, and during these events, Agri-Energy shall minimize emissions to the greatest extent practicable. To the extent practical, startup and shutdown of control technology systems will be performed during times when process equipment is also shut down for routine maintenance. In addition to the limits listed below, all emission sources will comply with a 12-month rolling sum source wide SO₂ cap of 95 TPY.

Any deviation from the requirements in 4.0 and/or 4.1 shall be reported in the quarterly reports and as required under other state and federal rules.

Process Description	Control Device #	Control Device Description	Pollutant	Short Term Emission Rate	Long Term Emission Rate
Fermentation and Beer Well	CE 003	Packed Bed	VOC	95% reduction or ≤ 10 ppm; lb/hr limits to be established based on performance testing under the process outlined under paragraph 24 of the Consent Decree.	12-month rolling sum source wide VOC cap of 95 TPY.
	CE 006	Wet Scrubber and TO			
			HAPs		12-month rolling sum source wide cap of 9.0 TPY for any single HAP and 24.0 TPY for total HAPs.

Process Description	Control Device #	Control Device Description	Pollutant	Short Term Emission Rate	Long Term Emission Rate
Cyclone Cooler	NA	TBD	VOC	To be established pursuant to paragraph 22 of the Consent Decree	12-month rolling sum source wide VOC cap of 95 TPY.
			HAPs		12-month rolling sum source wide cap of 9.0 TPY for any single HAP and 24.0 TPY for total HAPs.

Process Description	Control Device #	Control Device Description	Pollutant	Short Term Emission Rate	Long Term Emission Rate
DDGS Dryer, Ethanol Truck Loadout	CE 006	Thermal Oxidizer for VOC, PM/PM ₁₀ and CO control Thermal oxidizer has low NO _x burners.	CO	90% reduction or ≤100 ppm	12-month rolling sum source wide CO cap of 95 TPY.
			NO _x		12-month rolling sum source wide NO _x cap of 95 TPY and 12-month rolling sum Dryer #1 and #2, TO, Boiler #1 and #2 combined NO _x limit equal to 35.5 TPY
			PM/PM ₁₀	To be tested pursuant to paragraph 24 of the Consent Decree.	12-month rolling sum source wide PM/PM ₁₀ cap of 95 TPY.
			VOC	95% reduction or ≤10 ppm; lb/hr limits to be established based on performance testing under the process outlined under paragraph 24 of the Consent Decree.	12-month rolling sum source wide VOC cap of 95 TPY.
			HAPs		12-month rolling sum total facility emission cap of 9.0 TPY for any single HAP and 24.0 TPY for total HAPs.

Process Description	Control Device #	Control Device Description	Pollutant	Short Term Emission Rate	Long Term Emission Rate
Boiler	NA	NA	NO _x		12-month rolling sum source wide NO _x cap of 95 TPY and 12-month rolling sum Dryer #1 and #2, TO, Boiler #1 and #2 combined NO _x cap equal to 35.5 TPY

For all source-wide emission limits established under the Consent Decree, compliance with the "12-month rolling sum" will be demonstrated during the first 11 months of operation beginning no later than 120 days after startup of the last piece of control equipment required under the consent decree, based on the following schedule of limits in tons per month:

	Mo 1	Mo 2	Mo 3	Mo 4	Mo 5	Mo 6	Mo 7	Mo 8	Mo 9	Mo 10	Mo 11
VOC, CO, NO _x and PM/PM10	12	24	36	45	56	64	72	80	84	88	92
NO _x for Dryer, Boiler and TO	4	8	12	16	20.8	23.8	26.8	29.8	31.3	32.8	34.3
Individual HAP/	1.6/	3.2/	4.0/	4.8/	5.6/	6.4/	7.2/	8.0/	8.2/	8.5/	8.8/
Total HAPs	3.0	6.0	9.0	12	14	16	18	20	21	22	23

4.1 Alternative Operating Scenario

Ethanol truck load out shall be vented to the feed dryer control equipment whenever the control equipment is in operation. Ethanol truck load out shall be limited to 2 million gallons per year of uncontrolled operation. Fermentation emissions will be controlled only by the wet scrubber during periods of Thermal Oxidizer downtime. The facility may continue to operate and produce wet cake during periods of dryer control device downtime.

5.0 POLLUTION CONTROL EQUIPMENT INSTALLATION SCHEDULE

Thermal Oxidizer

Start of construction	June 30, 2002
Initial firing and check out of TO	October 15, 2002
Start of operation with dryer exhaust online	November 15, 2002
Order truck load-out and fermentation vent equipment	August 30, 2002
Start construction of vent line ductwork	October 1, 2002
Install mechanical and electrical equipment	October 15, 2002
Complete tie in of truck load-out and fermentation vent to TO	November 15, 2002
Final check out and start of operation with truck load-out and fermentation vent to TO	December 1, 2002

Additional HAPs control (if deemed necessary to stay synthetic minor for HAPs)

Order HAPs control equipment	Submittal of test reports showing major HAPs status + 1 month
Install mechanical and electrical equipment	Submittal of test reports showing major HAPs status + 9 months
Start of operation	Submittal of test reports showing major HAPs status + 12 months

6.0 MONITORING PARAMETERS FOR POLLUTION CONTROL DEVICES

The consent decree requires that monitoring parameters be established for affected pollution control devices. Beginning no later than 60 days following startup of a control device described below, Agri-Energy agrees to the following monitoring parameters for each of the affected pollution control devices.

Control Device #	Control Device Description	Parameter Monitored	Operating Range	Monitoring Frequency
CE 003	Packed Bed Wet Scrubber	Liquid Flow Rate	≥ 10 gallons per minute when vented to TO and > 20 gpm when vented to atmosphere	Continuously
		Pressure Drop	2 to 10 inches of water	Daily
CE 006	Thermal oxidizer with low NO _x burners	Operating Temperature	≥ 1400 F combustion chamber temperature	Continuously with low temperature alarm
		Dryer syrup feed rate and beer feed rate		24-hour average
Dryer, Boiler and TO annual NO _x limit (12-month rolling sum)	Low NO _x burners on TO	Fuel usage and fuel type (natural gas or propane)	0 to 4680 MMBtu/day for all units.	Weekly monitor and record fuel type and usage for each unit or emission point. Calculate NO _x emissions weekly based on latest stack test data.
FS 005	Leak detection and repair	Per NSPS subpart VV	Per NSPS subpart VV	Per NSPS subpart VV

All monitoring data collected above shall be recorded and maintained on-site. Any deviation of monitoring frequency, record keeping and range shall be reported in the quarterly reports and as required under other state and federal rules.

7.0 POLLUTION CONTROL DEVICE PERFORMANCE TEST SCHEDULE AND TEST METHODS USED

The following schedule and methods will be used to demonstrate compliance with the emission limits contained in Section 4.0 of this Control Technology Plan and the Consent Decree.

Agri-Energy shall conduct the following performance testing pursuant to the schedule under paragraph 28 of Consent Decree.

Emission unit/Control system	Pollutant tested	EPA test method
DDGS dryer, fermentation and truck load-out /TO (TO outlet)	Total VOC, Speciated VOCs/HAPs, NOx, CO, PM/PM-10	Method 1, 2, 3A or B, 4, 5/202, 7E, 10, 18 NCASI CI/WP-98.01 and 25 in accordance with a test protocol approved by the parties, unless THC ppm < 50 ppm, then 25A.
DDGS dryer/none (TO inlet)	Total VOC, Speciated VOCs/HAPs, PM/PM-10, CO and NOx	Method 1, 2, 3A or B, 4, 5/202, 7E, 10, 18 NCASI CI/WP-98.01 and 25 in accordance with a test protocol approved by the parties, unless THC ppm < 50 ppm, then 25A.
Fermentation/wet scrubber (outlet) with Water flowrate > 20 gpm	Total VOC, Speciated VOCs/HAPs,	Method 1, 2, 3A or B, 4, 18 NCASI CI/WP-98.01 for HAPs. VOCs will be tested in accordance with a test protocol approved by the parties.
Cyclone Cooler	Total VOC, Speciated VOCs/HAPs,	Method 1,2, 3A or B, 4, 18 NCASI CI/WP-98.01 and 25 in accordance with a test protocol approved by the parties, unless THC ppm < 50 ppm, then 25A.
Boiler	NOx and CO	Method 7E and 10

8.0 FUGITIVE DUST EMISSION CONTROL PROGRAM

Agri-Energy will initiate application of an approved dust suppressant on its roads to control fugitive road dust emissions. Initially, but subject to change at Agri-Energy discretion to another company or another approved dust suppressant, Agri-Energy will employ the services of Environmental Dust Control, Inc. (EDC) to mitigate fugitive road dust. EDC will apply their specially formulated DUSTLOCK chemical to all roadways at the facility. Beginning no later than 30 days following lodging of the Consent Decree, Agri-Energy will comply with the monitoring and recordkeeping provisions set forth below.

Application Schedule

Scheduled	Not scheduled
Annually, starting September 2002. Application will cover facility roadways.	As needed per periodic observations. Application may be spot specific (i.e. corners and turn-arounds) or entire facility.

Monitoring

Parameter	Set Point/Range	Frequency
Visible road dust from all sections of facility roadway	No visible road dust	Weekly, personnel will inspect facility roadway surface for wear, frost boils, etc and will observe truck traffic at each corner for signs of visible emissions.

Record Keeping

Personnel will record roadway inspection observation data including but not limited to:

Date and time of inspection, name of inspector, map or site plan showing locations and site lines of Visible Emissions observations and locations of road surface problem areas, corrective actions taken to eliminate visible emissions or problem surface conditions.

Any deviation of monitoring frequency and range shall be reported in the quarterly reports and as required under other state and federal rules.

Agri-Energy
Emission Calculations for Dryer, Boiler and TO NOx Limit

Normal operation		Natural gas curtailment	
All units burning only pipeline quality natural gas for 344 days per year			
Assume 0.04 lbs/MMBtu average emission factor and 8256 hours of operation per year.			
Source	Capacity (MMBtu/hr)	Source	Capacity (MMBtu/hr)
Dryer	55	Dryer	55
TO	78	TO	78
Boiler	62	Boiler	62
Total	195	Total	195
0.04 lbs/MMBtu X 195 MMBtu/hr =		0.04 lbs/MMBtu X 55 MMBtu/hr =	
		0.08 lbs/MMBtu X 140 MMBtu/hr =	

NOx	lbs/hr	TPY
	7.8	32.20
	13.4	3.38
		35.58

Natural gas for 344 days
Propane and natural gas for 21 days
Total

New lbs/MMBtu emission factors, determined from unit specific testing, and unit specific fuel usage will be used to calculate actual NOx emissions upon completion of testing.

NOx emissions in TPY =
$$\sum_{i=1}^{52} D \times F D_i + T O \times F T O_i + B \times F B_i$$

Stack testing based emission factors
D = Dryer emission factor (based on stack testing)
TO = TO emission factor (based on stack testing)
B = Boiler emission factor (based on stack testing)

FD = Dryer fuel usage for week i (MMBtu)
FTO = TO fuel usage for week i (MMBtu)
FB = Boiler fuel usage for week i (MMBtu)